

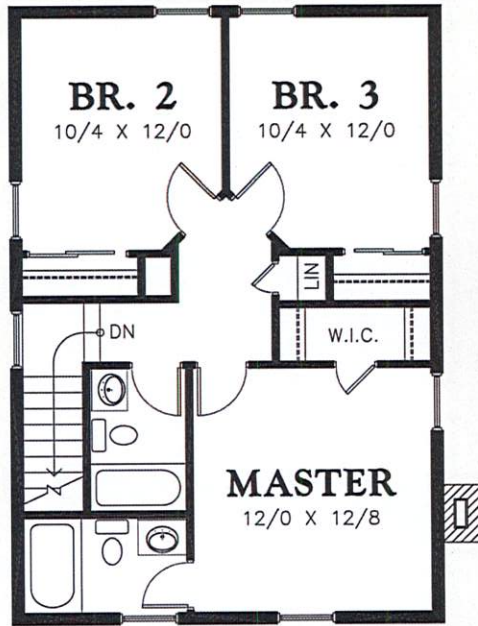

*Mascord*  
ALAN MASCORD DESIGN ASSOCIATES, INC.

The Juniper  
**2118B**

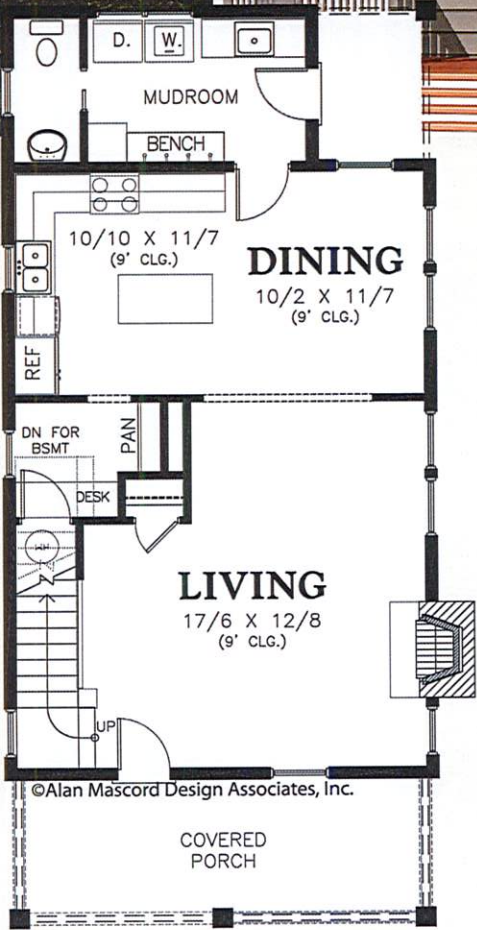

Upper Floor	658 Sq. Ft
Main Floor	832 Sq. Ft
<b>Total Area</b>	<b>1490 Sq. Ft</b>
<b>Width</b>	<b>Depth</b>
22'-0"	47'-6"
<b>Height</b>	(Main Flr to Peak): 28'-0"
	(to Midpt of Roof): 23'-0"



**ALAN MASCORD DESIGN ASSOCIATES, INC**  
2187 NW Reed St, Suite 100, Portland, OR 97210 · 503.225.9161  
mascord.com | houseplans.co

Copyright © 2019 Alan Mascord Design Associates, Inc. All Rights Reserved.

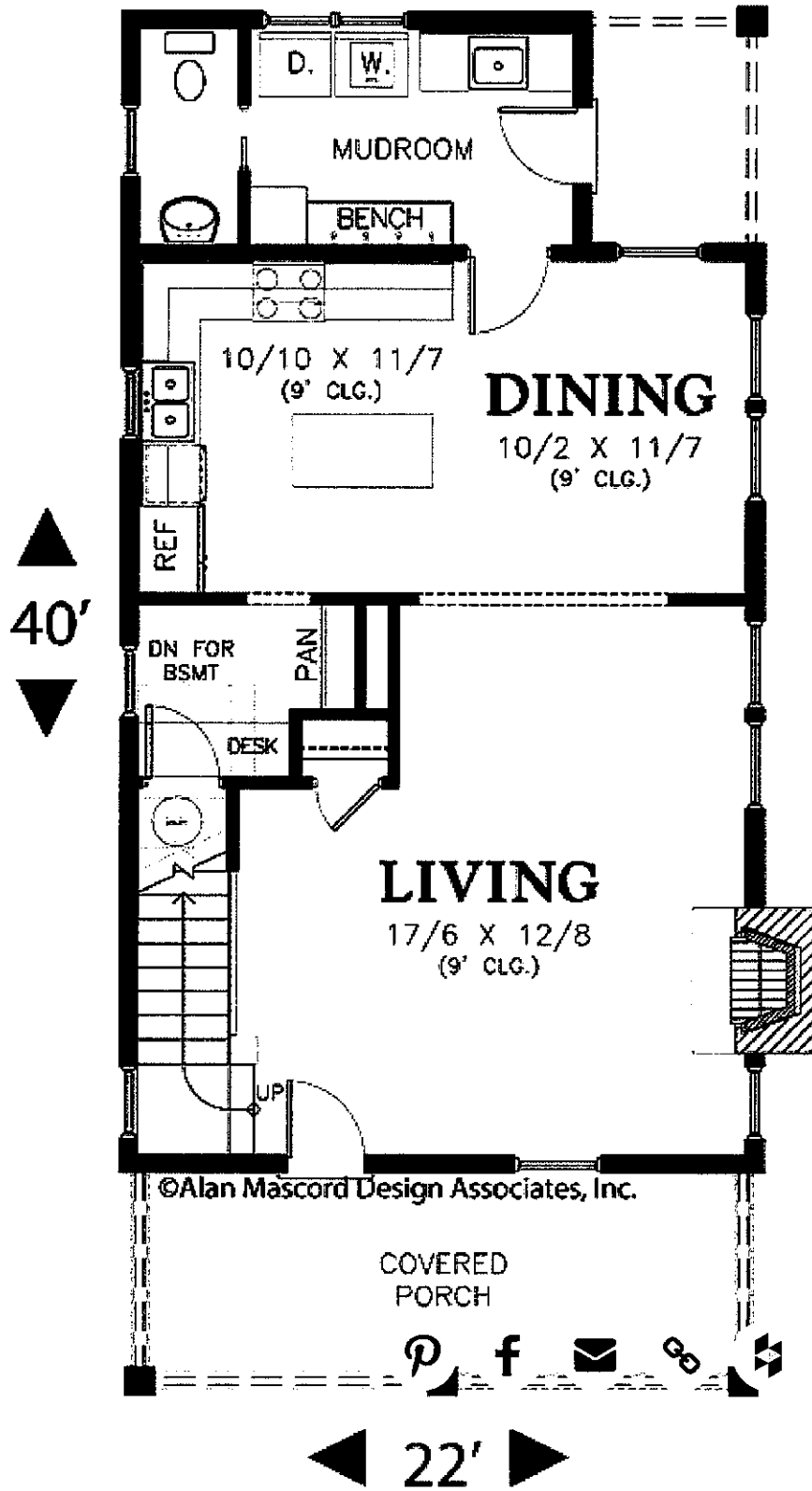

### Main Floor Plan

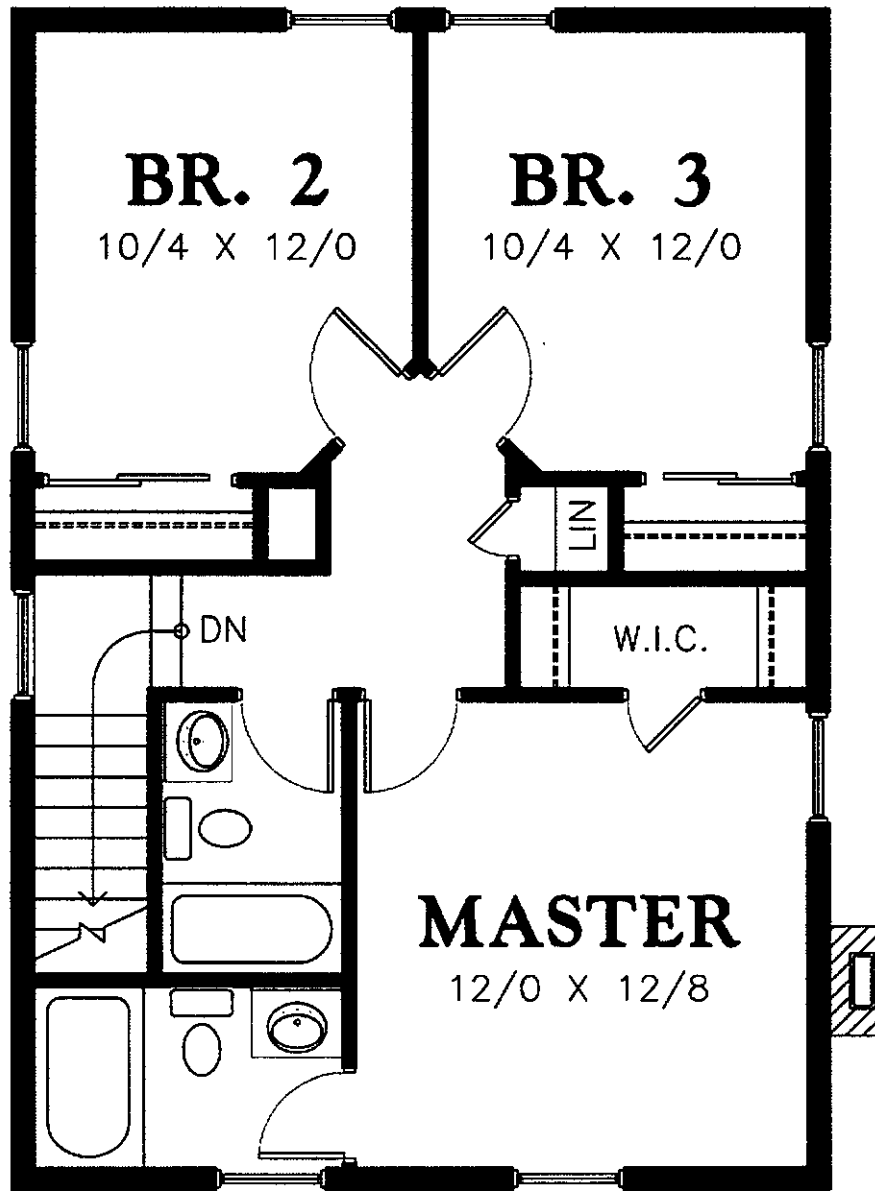

### Upper Floor Plan

# Turner

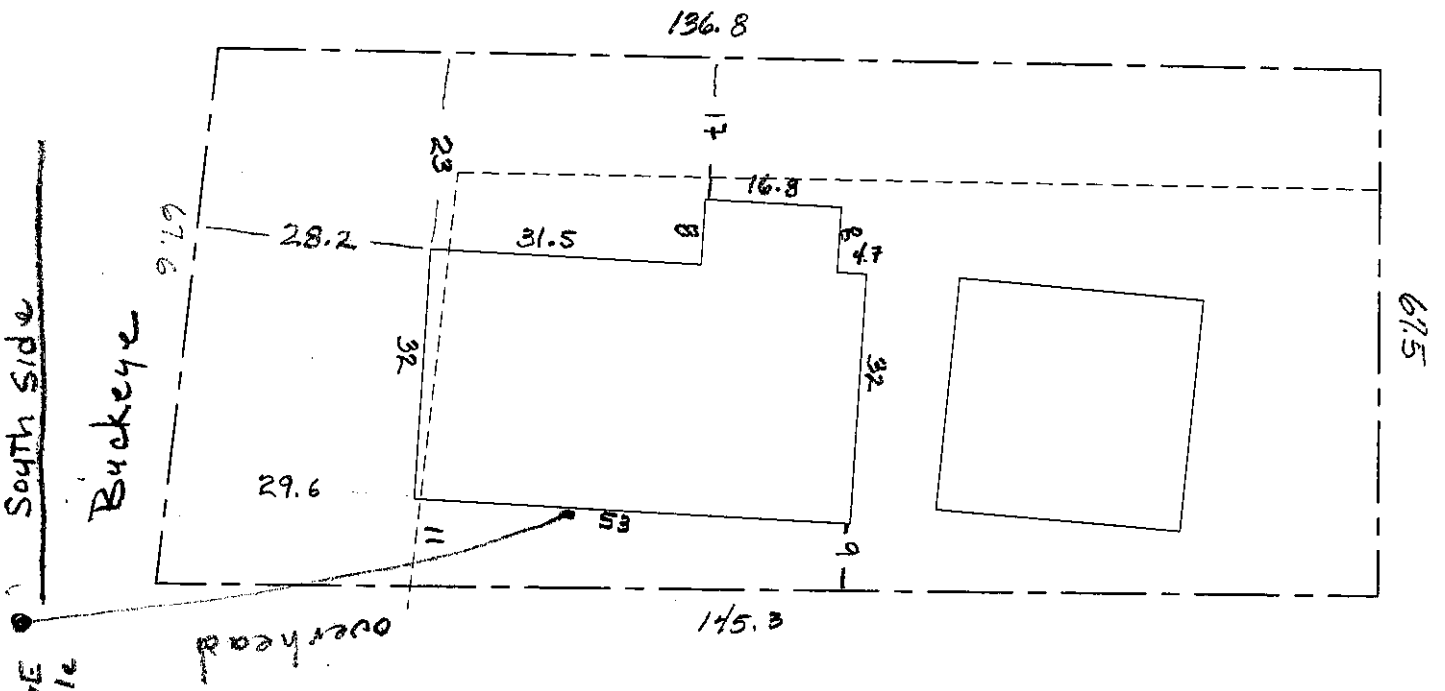

Existing MGE Pole

