

## 4082 Hoepker Road

Project No. 12471

Contract No. 8426

\*Construction of new sidewalk along Hoepker Road adjacent to project

\*Dedication of 15 foot wide strip of Right of Way along Hoepker Road

\*Dedication of a Permanent Limited Easement for grading and sloping 20 feet wide along the new Right of Way on Hoepker Road

\*Installation of a new water lateral to serve the property

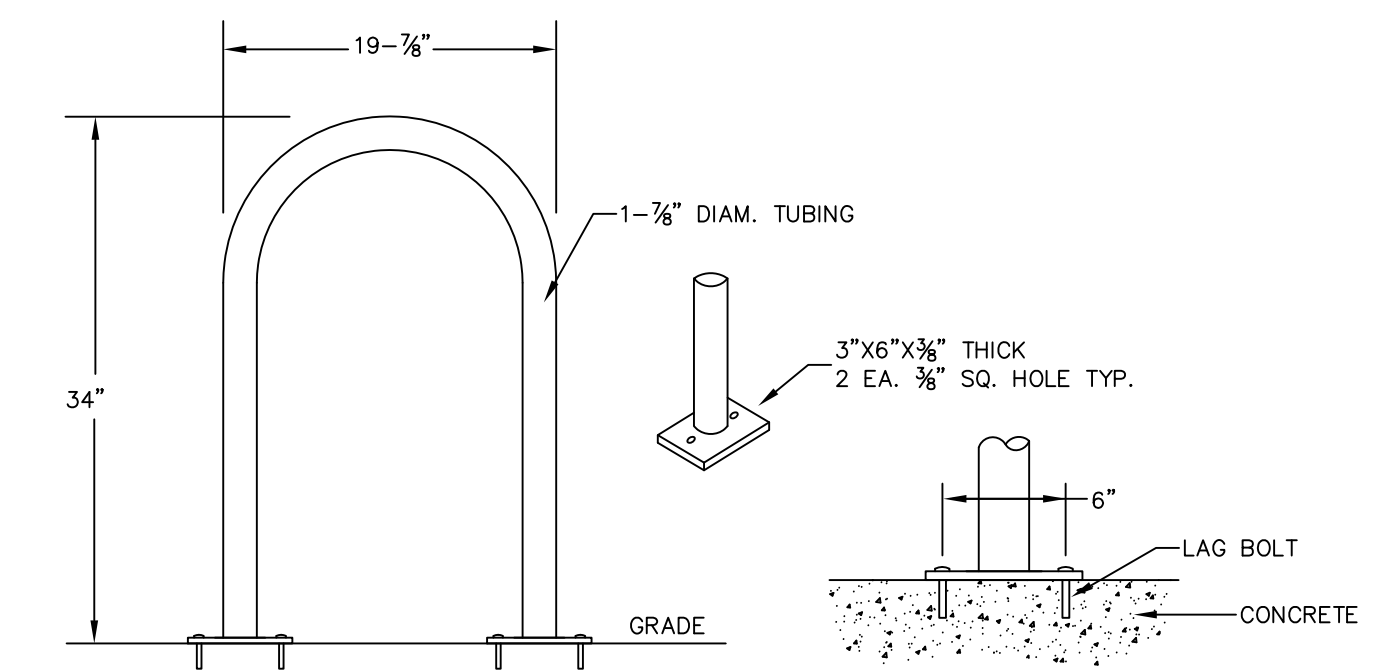
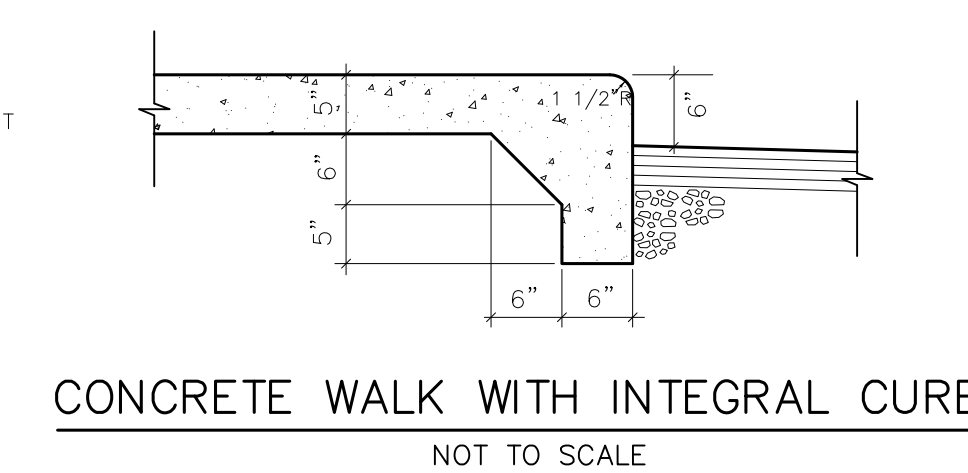
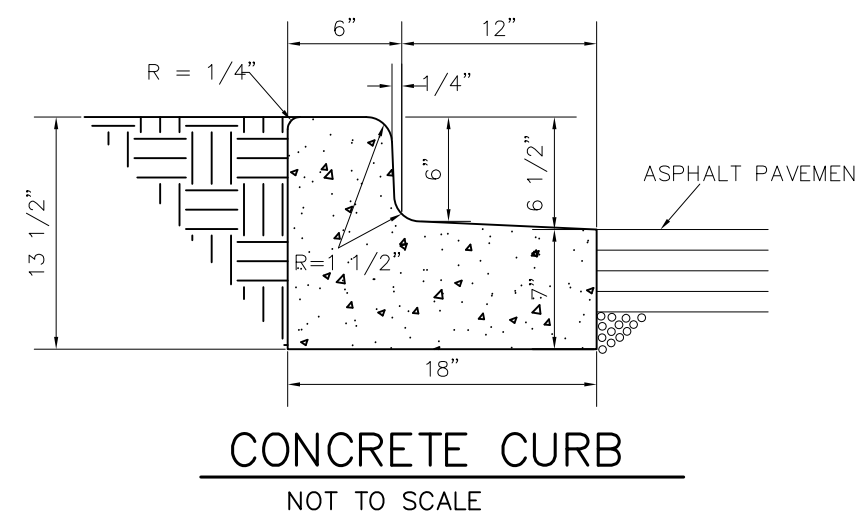
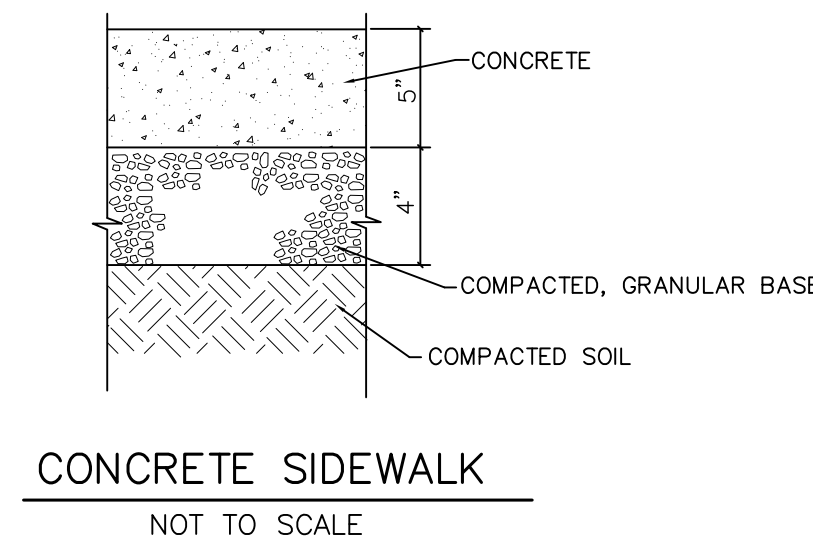
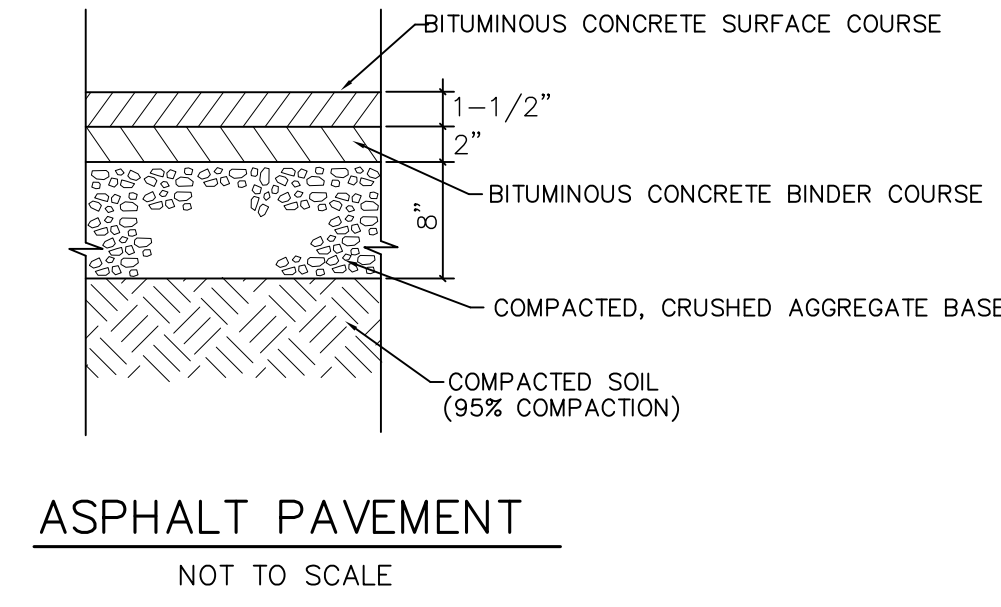
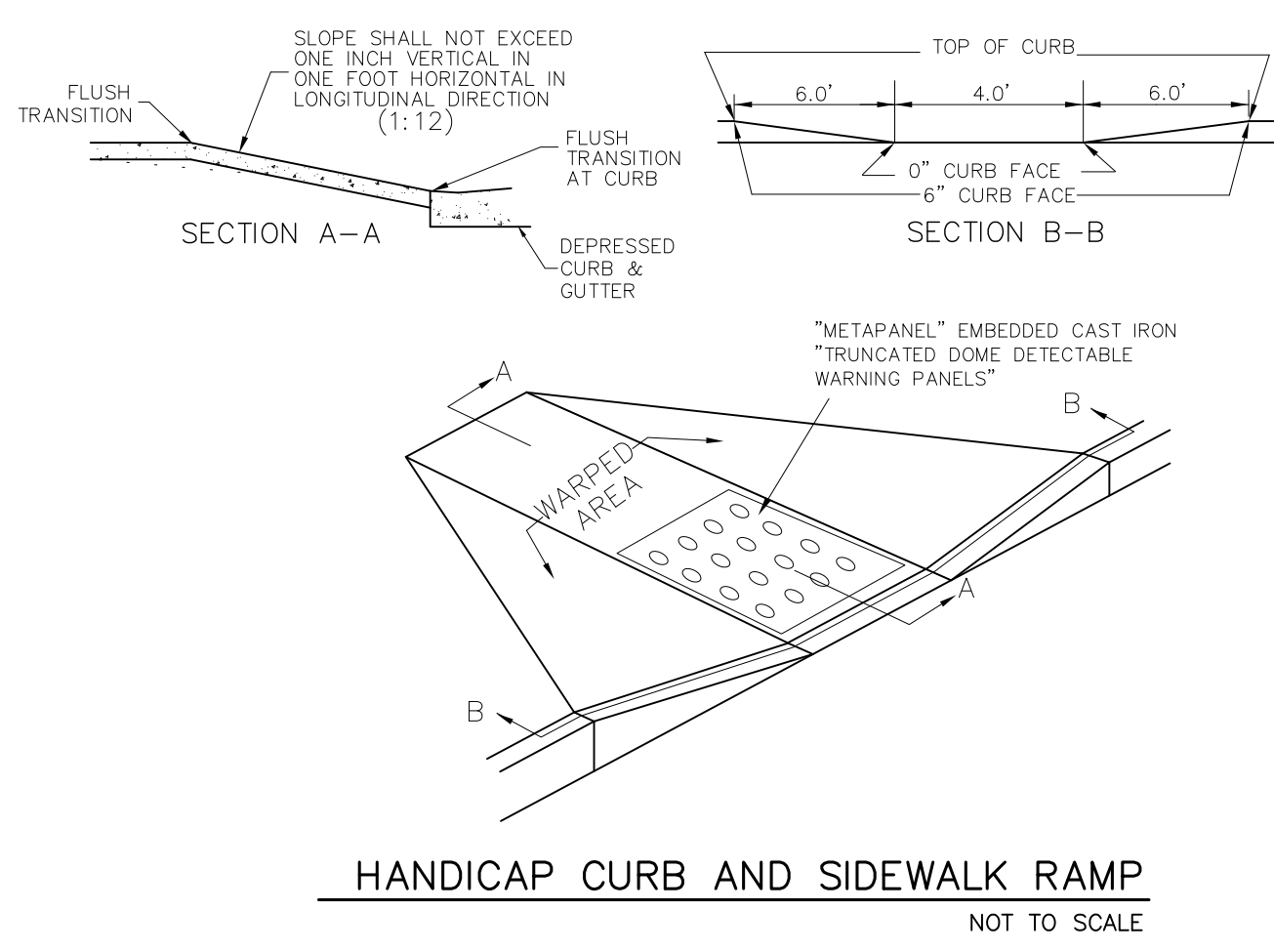

PRODUCT: U190-SF  
 DESCRIPTION: "U" BIKE RACK  
 2-BIKE, SURFACE MOUNT  
 POWDER COATED FINISH  
 -INSTALL PER MANUFACTURER'S SPECIFICATIONS

**MADRAX "U" BIKE RACK DETAIL**  
 NOT TO SCALE

**HANDICAP CURB AND SIDEWALK RAMP**  
 NOT TO SCALE

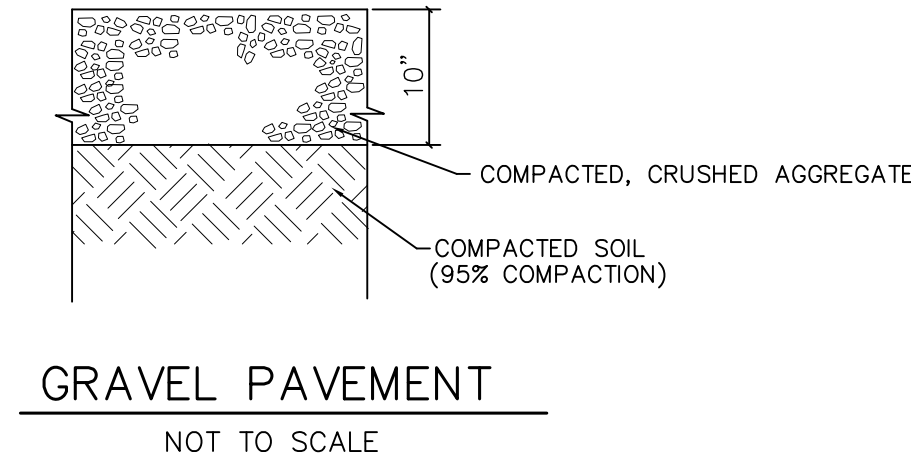

**GRAVEL PAVEMENT**  
 NOT TO SCALE

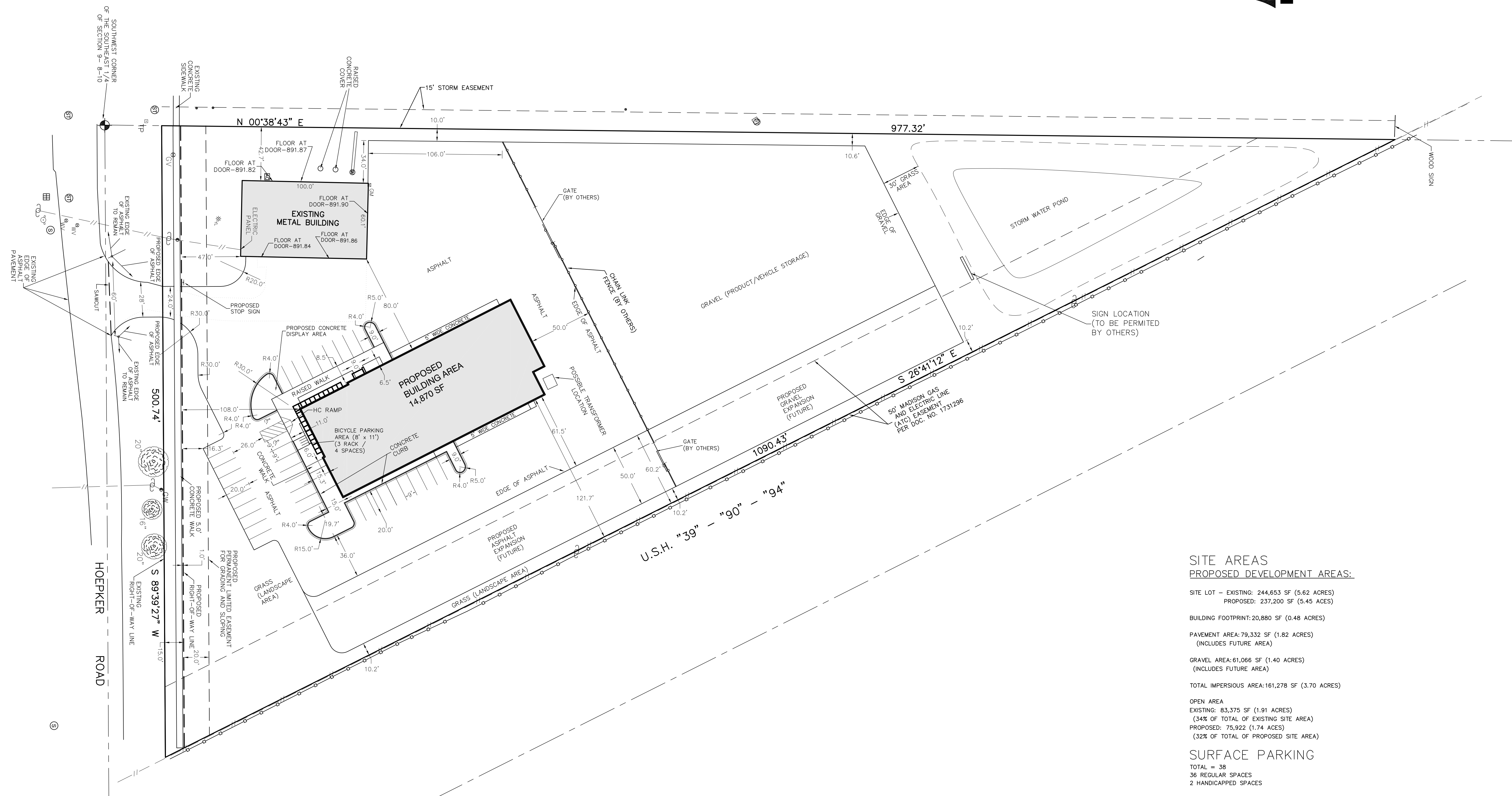

**SITE AREAS**  
**PROPOSED DEVELOPMENT AREAS:**

SITE LOT - EXISTING: 244,653 SF (5.62 ACRES)  
 PROPOSED: 237,200 SF (5.45 ACRES)

BUILDING FOOTPRINT: 20,880 SF (0.48 ACRES)

PAVEMENT AREA: 79,332 SF (1.82 ACRES)  
 (INCLUDES FUTURE AREA)

GRAVEL AREA: 61,066 SF (1.40 ACRES)  
 (INCLUDES FUTURE AREA)

TOTAL IMPERVIOUS AREA: 161,278 SF (3.70 ACRES)

OPEN AREA

EXISTING: 83,375 SF (1.91 ACRES)  
 (34% OF TOTAL OF EXISTING SITE AREA)

PROPOSED: 75,922 SF (1.74 ACRES)  
 (32% OF TOTAL OF PROPOSED SITE AREA)

**SURFACE PARKING**

TOTAL = 38

36 REGULAR SPACES

2 HANDICAPPED SPACES

4 EXTERIOR BICYCLE PARKING SPACES

- NOTES:**
1. ALL DIMENSIONS ARE TO FACE OF CURB, WALK OR TO EDGE OF PAVEMENT.
  2. DISTURBED AREA = 221,400 S.F. (5.08 ACRES)
  3. ALL DAMAGE TO THE PAVEMENT IN HOEPKER ROAD ADJACENT TO THIS DEVELOPMENT SHALL BE RESTORED IN ACCORDANCE WITH THE CITY'S PAVEMENT PATCHING CRITERIA. ALL PAVEMENT DAMAGED BY CONSTRUCTION SHALL BE REPLACED IN ACCORDANCE TO CITY REQUIREMENTS AND SPECIFICATIONS.
  4. ALL THE WORK IN THE PUBLIC RIGHT-OF-WAY SHALL BE PERFORMED BY A CITY-LICENSED CONTRACTOR.
  5. THE NEW 5' CONCRETE PUBLIC WALK SHALL BE DONE PER CITY REQUIREMENTS AND SPECIFICATIONS.
  6. EXISTING DRIVEWAY TO BE REPAVED

