

VLET/  
 CASTING  
 12+29.63  
 PI  
 FC 923.28  
 Inv 919.08  
 S-1  
 CONCRETE COLLAR  
 INVERT 919.50  
 2-INCH RCP  
 TA 11+93.70, RT 21.00'  
 YPE H INLET W/ SALVAGED CASTING  
 INVERT 919.70  
 C 922.85  
 3.70, RT 21.00'  
 INLET  
 EXISTING CURB &  
 GUTTER TO REMAIN  
 REMOVE EXISTING CURB & GUTTER  
 & CONCRETE PAVEMENT & MEDIAN  
 CONCRETE

CP #AME1  
 N=509538.4660  
 E=846215.2590  
 ELEV=927.2300

EASTPARK BLVD

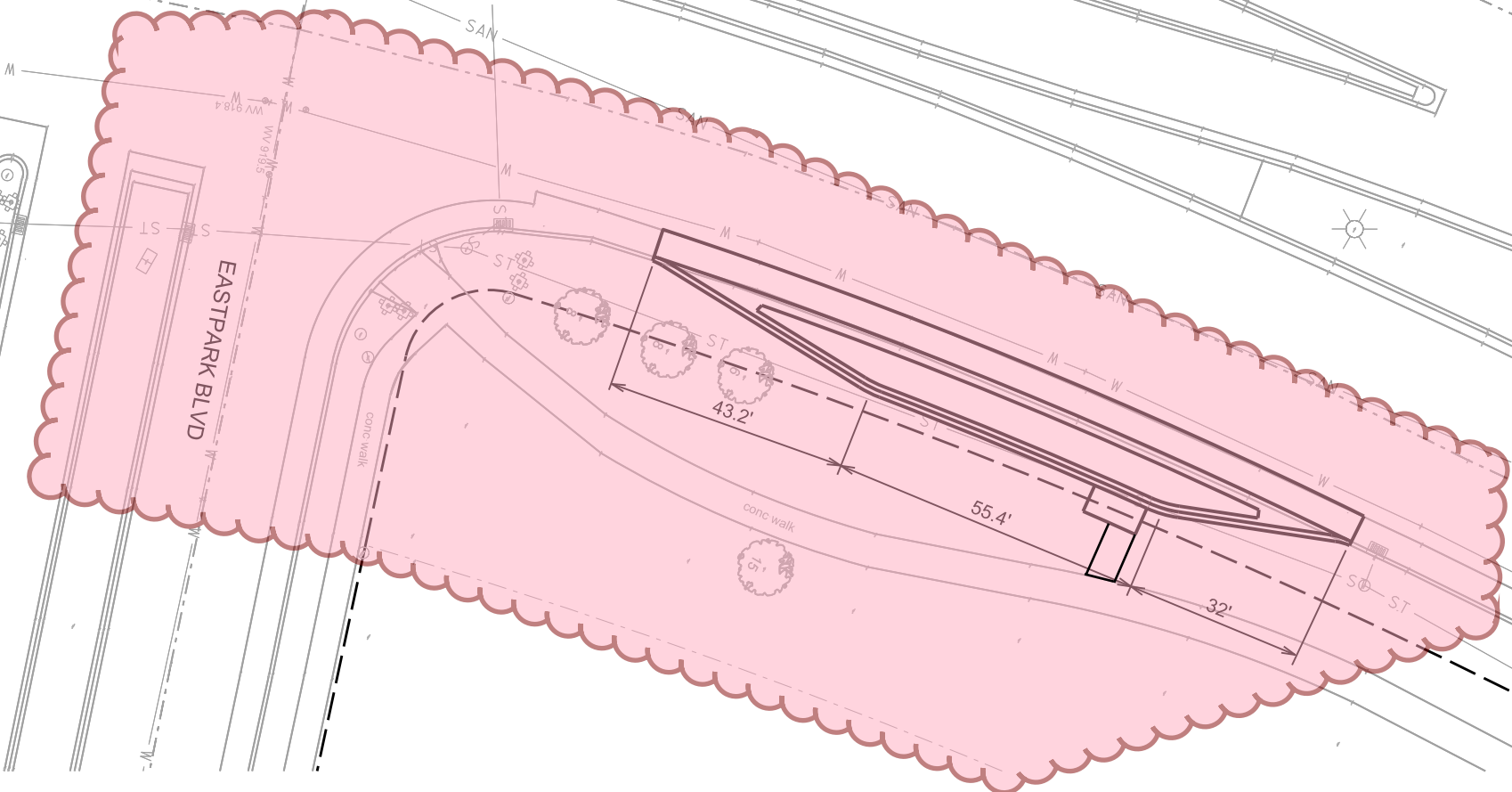

AMERICAN PARKWAY

ASTPARK BLVD

ASTPARK BLVD