

PRELIMINARY PLAT OF JANNAH VILLAGE

A parcel of land located part of the Northeast 1/4 of the Southwest 1/4 and part of the Southeast 1/4 of the Southwest 1/4 of Section 35, T8N, R10E, City of Madison, Dane County, Wisconsin, including part of Lot 2 Certified Survey Map No. 1799, recorded in the Dane County Register of Deeds Office in Volume 7 of Certified Survey Maps of Dane County on Page 207 and 208, as Document No. 1443114.

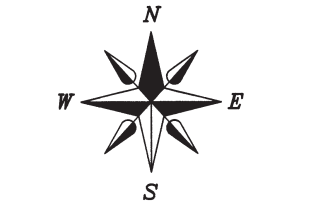
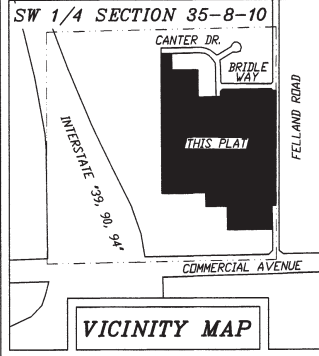

WCCS - DANE COUNTY
 BEARINGS ARE REFERENCED TO THE EAST LINE OF THE SOUTHWEST 1/4 OF SECTION 35, T8N, R10E, LINE TO BEAR = N 00°49'57" E
 SCALE 1" = 100'

OWNERS / SUBDIVIDER:
 LINDSAY HAGENS
 SIMPLY HOMES MADISON LLC
 517 BUTTEFIELD DRIVE
 MADISON, WI 53704

ENGINEER:
 QUAM ENGINEERING, LLC
 4604 SIGLEKOW ROAD, SUITE 'A'
 MCFARLAND, WI 53558

SURVEYOR:
 WILLIAMSON SURVEYING AND ASSOCIATES, LLC
 104A WEST MAIN STREET
 WAUNAKEE, WI 53597

- LEGEND**
- = FOUND 3/4" REBAR
 - = FOUND 1 1/4" REBAR
 - ⊗ = FOUND 1" IRON PIPE
 - ⊙ = FOUND DANE COUNTY SECTION CORNER (AS NOTED)
 - ⊙ = RECORDED AS
 - = EXISTING CONTOURS
 - = PROPOSED UTILITY EASEMENTS (WITH NOTED)

ZONING:

LOT No.	ZONING
LOT 1	TR-U1 TRADITIONAL RESIDENTIAL
LOTS 2-6	SR-V2 SUBURBAN RESIDENTIAL
LOTS 7-10	SR-C3 SUBURBAN RESIDENTIAL
LOTS 11-59	SR-C1 SUBURBAN RESIDENTIAL

LINE TABLE:

L-#	BEARING	DISTANCE
L-1	S 00°51'57" W	70.00
L-1	N 00°12' E	200.00
L-2	N 00°50'59" E	200.15
L-2	N 89°48' W	122.41
L-3	N 89°22'27" W	122.49

CURVE TABLE:

C-#	RADIUS	CHORD BEARING	ARC	DELTA
C-1	20.00	N 44°48'00" W 28.28	31.79	91°04'13"
C-2	20.00	S 45°38'17" W 28.08	31.13	89°10'54"

- NOTES:**
- ALL ELEVATIONS ARE REFERENCED TO NAVD 88 (2012 DATUM). CONTOURS SHOWN ARE TO EXISTING CONDITIONS.
 - TOTAL AREA INCLUDING RIGHT OF WAY = 1,902,413 SQ. FT. OR 43.67 ACRES. TOTAL AREA EXCLUDING 33' RIGHT OF WAY OF FOLLAND ROAD = 1,859,102 SQ. FT. OR 42.68 ACRES.
 - LOTS WITHIN PLAT: 59 LOTS AND 3 OUTLOTS.

DESCRIPTION:

A parcel of land located part of the Northeast 1/4 of the Southwest 1/4 and part of the Southeast 1/4 of the Southwest 1/4 of Section 35, T8N, R10E, City of Madison, Dane County, Wisconsin, including part of Lot 2 Certified Survey Map No. 1799, recorded in the Dane County Register of Deeds Office in Volume 7 of Certified Survey Maps of Dane County on Page 207 and 208, as Document No. 1443114; being more particularly described as follows:

Commencing at the South 1/4 corner of Section 35; thence N 00°49'57" E along the East line of the Southwest 1/4, 613.38 feet to the point of beginning.

Thence continue N 00°49'57" E, 1312.45 feet to a Southeast corner of Bridle Downs Plat; thence along said Bridle Downs Plat for the next 10 courses N 89°12'51" W, 39.32 feet; thence along an arc of a curve concave southwesterly having a radius of 20.00 feet and a long chord bearing of N 44°13'00" W, 28.55 feet; thence N 89°14'01" W, 549.81 feet; thence along an arc of a curve concave southeasterly having a radius of 20.00 feet and a long chord bearing of S 45°38'17" W, 28.08 feet; thence S 00°51'57" W, 70.06 feet; thence N 89°14'20" W, 260.00 feet; thence N 00°49'56" E, 310.11 feet; thence N 89°15'03" W, 300.14 feet; thence N 00°50'59" E, 200.15 feet; thence N 89°22'27" W, 122.49 feet; thence S 00°46'45" W, 1611.27 feet to the Northwest corner of Lot 1 Certified Survey Map No. 5458; thence along said Lot 1 for the next two courses N 89°00'13" E, 509.38 feet; thence S 00°11'32" W, 156.50 feet to the North line of said Lot 2 Certified Survey Map No. 1799; thence S 89°12'06" E along the North line of said Lot 2, 249.95 feet; thence S 00°43'34" W, 272.69 feet to the South line of said Lot 2; thence along said Lot 2 for the next courses S 89°12'02" E, 508.91 feet; thence N 00°49'57" E, 272.70 feet; thence S 89°12'06" E, 40.00 feet to the point of beginning. This parcel contains 1,902,413 sq. ft. or 43.67 acres and is subject to a road right of way of 33 feet over the easterly side thereof.

SURVEYOR'S CERTIFICATE:

I certify that this survey is correct to the best of my knowledge and belief and is in full compliance with the provisions of Chapter A-7 of the Wisconsin Statutes. Field work was completed on March 12, 2018.

Williamson Surveying and Associates, LLC
 by Noa T. Prieve & Chris W. Adams

Date: May 14, 2018

Noa T. Prieve S-2499
 Professional Land Surveyor

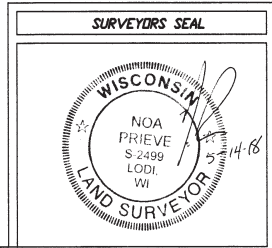
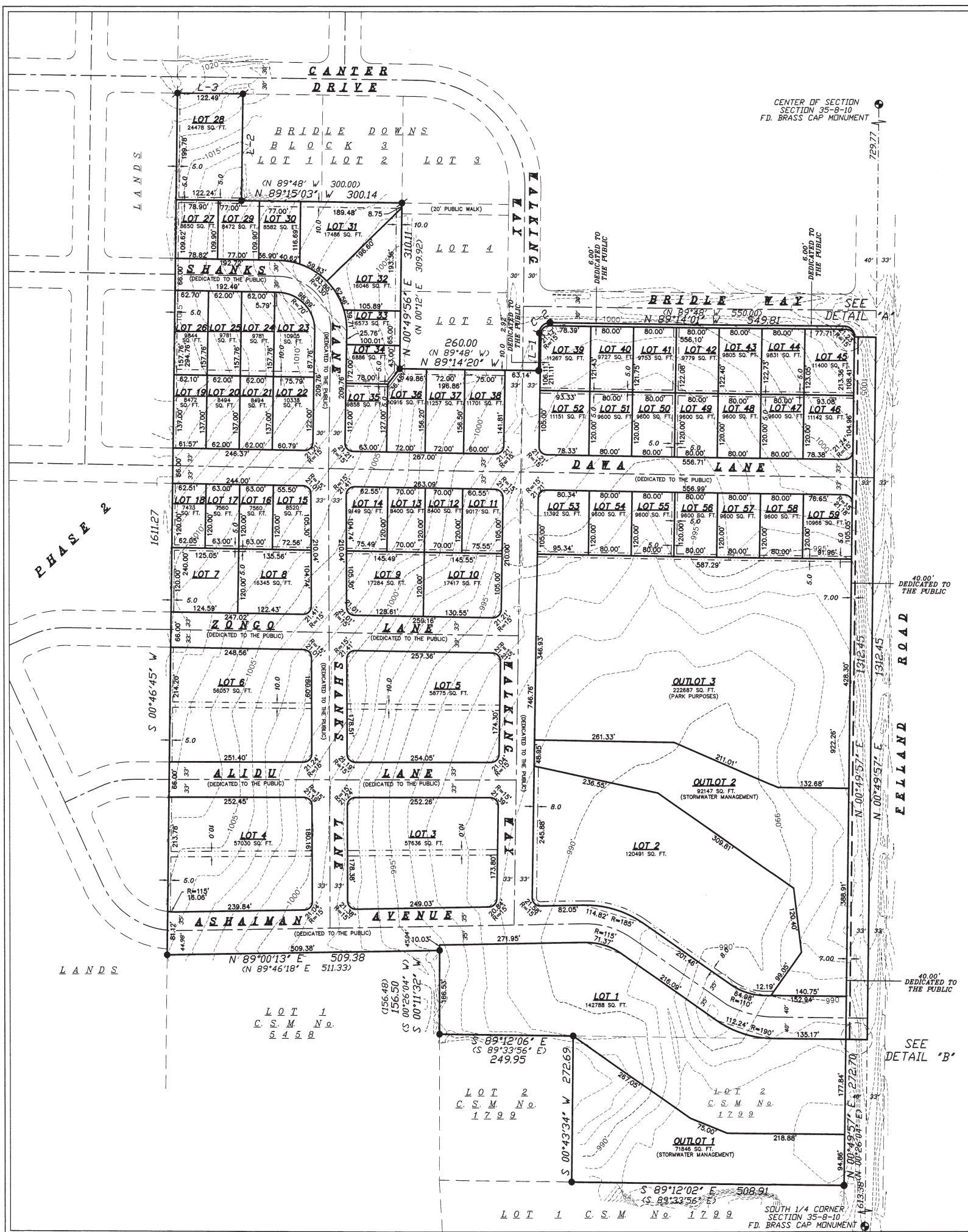
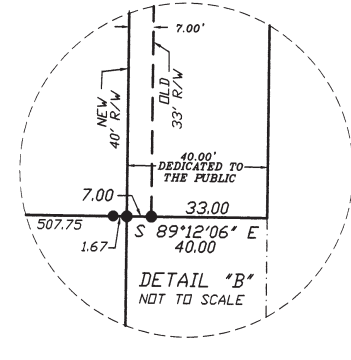
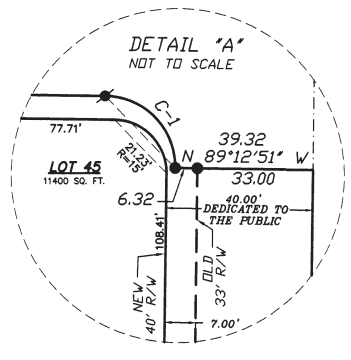

WILLIAMSON SURVEYING & ASSOCIATES, LLC
 104A WEST MAIN STREET, WAUNAKEE, WISCONSIN, 53597
 NOA T. PRIEVE & CHRIS W. ADAMS
 PROFESSIONAL LAND SURVEYORS
 PHONE: 608-255-5705 FAX: 608-849-9760 WEB: WILLIAMSONSURVEYING.COM

PRELIMINARY PLAT OF JANNAH VILLAGE

A parcel of land located part of the Northeast 1/4 of the Southwest 1/4 and part of the Southeast 1/4 of the Southwest 1/4 of Section 35, T8N, R10E, City of Madison, Dane County, Wisconsin.

DATE	MAY 8, 2018	REVISION DATE:	MAY 11, 2018	CHECK BY:	N.T.P.
SCALE:	1" = 100'	REVISION DATE:	MAY 14, 2018	DRAWING NO.	18V-94
DRAWN BY:	NEIL BORTZ			SHEET	1 OF 1