

CERTIFIED SURVEY MAP No. _____

LOTS 7 & 8, SAUK JUNCTION, AS RECORDED IN VOLUME 57-078A OF PLATS, ON PAGES 304-306, AS DOCUMENT NUMBER 2871526, DANE COUNTY REGISTRY, LOCATED IN THE NE 1/4-NE 1/4 OF SECTION 22, TOWNSHIP 07 NORTH, RANGE 08 EAST, CITY OF MADISON, DANE COUNTY, WISCONSIN.

SURVEY LEGEND

- FOUND 1 1/4" Ø IRON ROD
- FOUND 3/4" Ø IRON ROD
- ⊗ SET 3/4" x 18" SOLID IRON RE-ROD, WT. 1.50 lbs./ft. MIN.
- () RECORDED AS INFORMATION

NOTES:

1. See sheets 2 & 3 for existing building and easements detail.
2. See sheet 4 & 5 for new easements detail.
3. See sheet 6 for line and curve tables.
4. See sheet 7 for additional notes.
5. See sheet 8 for description & surveyor's certificate.



BEARINGS ARE BASED UPON THE WISCONSIN COUNTY COORDINATE SYSTEM, DANE COUNTY, THE NORTH LINE OF THE NE 1/4 OF SECTION 22-07-08 MEASURED AS BEARING S89°36'17"W

NORTH 1/4 CORNER OF SECTION 22-07-08 CONC. MON. WITH ALUMINUM DOT CAP FOUND PUBLISHED COORDS:
N=482918.57
E=781642.54

NORTHEAST CORNER OF SECTION 22-07-08 CONC. MON. WITH ALUMINUM DOT CAP FOUND PUBLISHED COORDS:
N=482936.70
E=784270.97

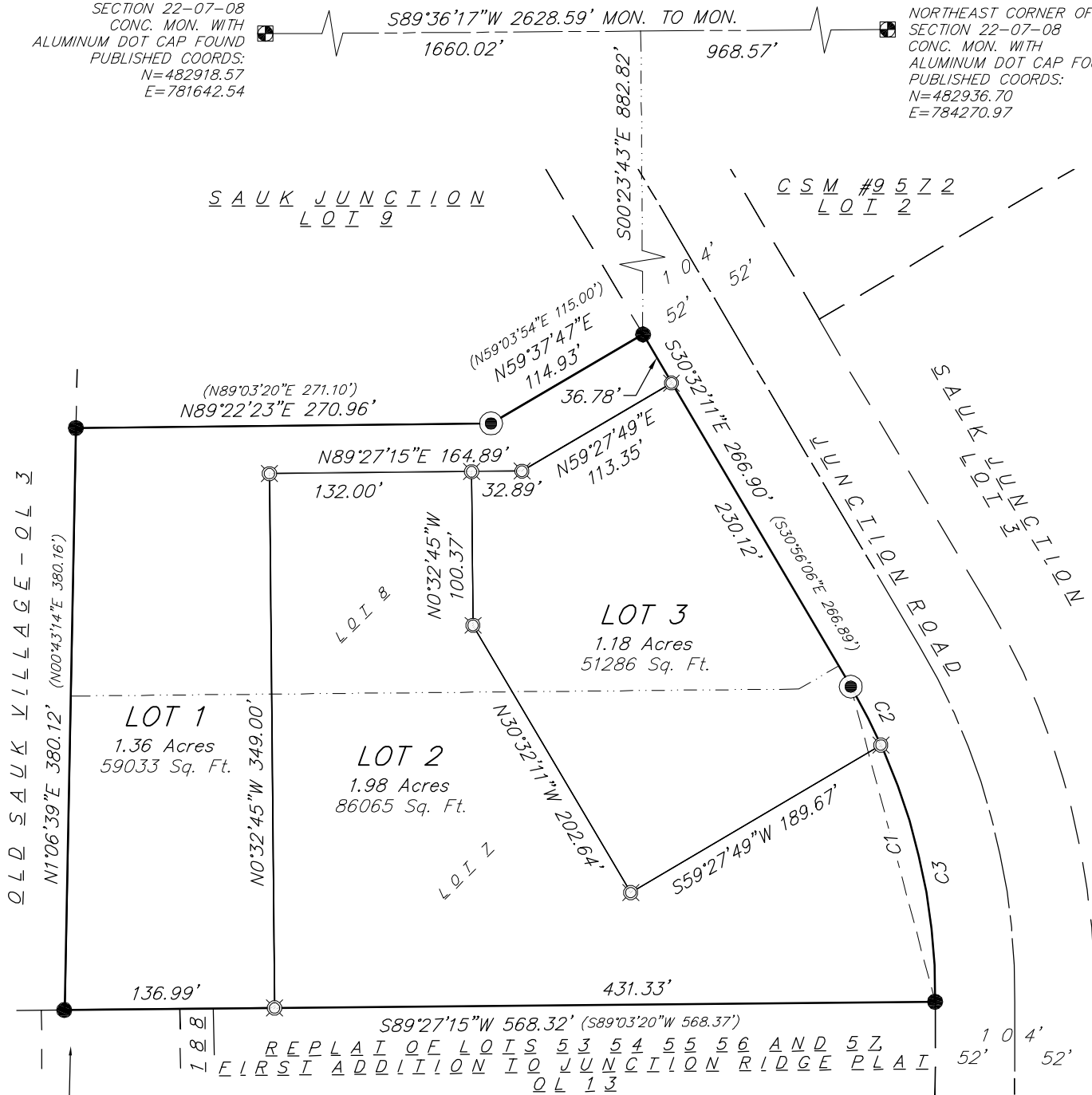

FIRST ADDITION TO JUNCTION RIDGE PLAT LOT 52

GRAPHIC SCALE FEET



05 Aug 2015 - 10:29a M:\LZ Ventures\150054_510 Junction Road\CADD\150054_CSM.dwg by: mmcr

vierbicher
planners | engineers | advisors



REEDSBURG - MADISON - PRAIRIE DU CHIEN
999 Fourier Drive, Suite 201 Madison, Wisconsin 53717
Phone: (608) 824-0532 Fax: (608) 824-0530

FN: 150054
DATE: 08/05/2015
REV:
Drafted By: MMAR
Checked By: PKNU

SURVEYED FOR:
LZ Ventures, LLC
5603 Surrey Lane
Waunakee, WI 53597

C.S.M. No. _____
Doc. No. _____
Vol. _____ Page _____

SHEET
1 OF 9

CERTIFIED SURVEY MAP No. _____

LOTS 7 & 8, SAUK JUNCTION, AS RECORDED IN VOLUME 57-078A OF PLATS, ON PAGES 304-306, AS DOCUMENT NUMBER 2871526, DANE COUNTY REGISTRY, LOCATED IN THE NE 1/4-NE 1/4 OF SECTION 22, TOWNSHIP 07 NORTH, RANGE 08 EAST, CITY OF MADISON, DANE COUNTY, WISCONSIN.



BEARINGS ARE BASED UPON THE WISCONSIN COUNTY COORDINATE SYSTEM, DANE COUNTY, THE NORTH LINE OF THE NE 1/4 OF SECTION 22-07-08 MEASURED AS BEARING S89°36'17"W

DETAIL
EXISTING SWITCHING STATION
BUILDING DETAIL
(NOT TO SCALE)

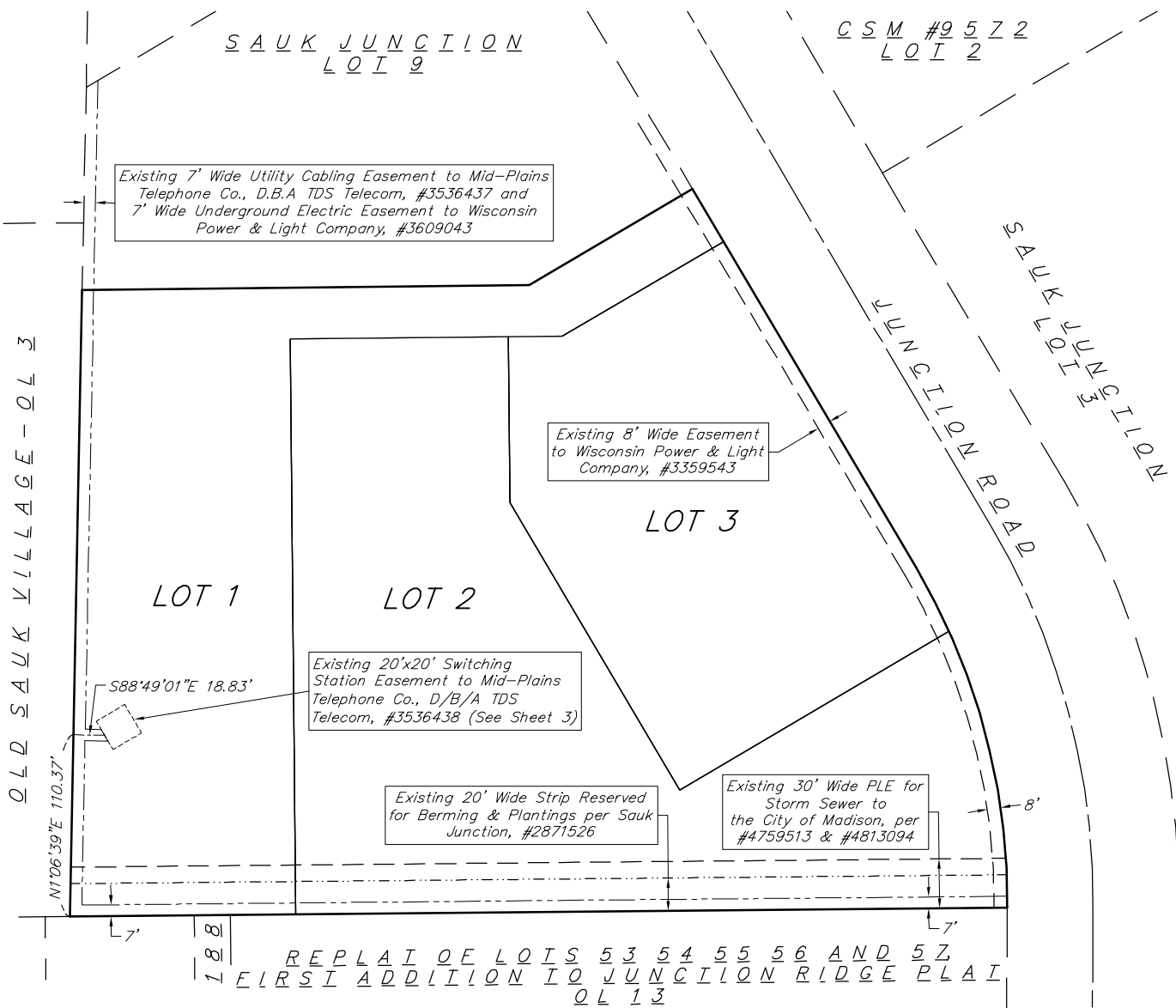
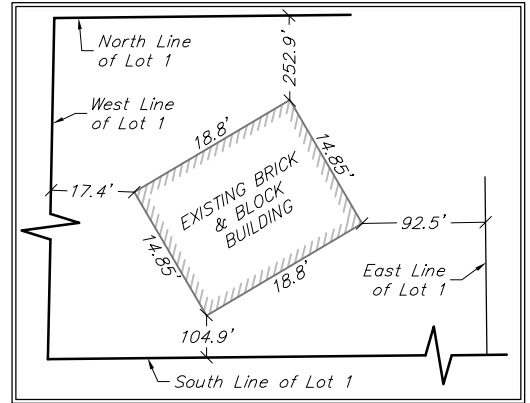

05 Aug 2015 - 10:29a M:\LZ Ventures\150054_510 Junction Road\CADD\150054_CSM.dwg by: mmr

vierbicher
planners | engineers | advisors



REEDSBURG - MADISON - PRAIRIE DU CHIEN
999 Fourier Drive, Suite 201 Madison, Wisconsin 53717
Phone: (608) 826-0532 Fax: (608) 826-0530

FN: 150054
DATE: 08/05/2015
REV:
Drafted By: MMAR
Checked By: PKNU

SURVEYED FOR:
LZ Ventures, LLC
5603 Surrey Lane
Waunakee, WI 53597

C.S.M. No. _____
Doc. No. _____
Vol. _____ Page _____

**SHEET
2 OF 9**

CERTIFIED SURVEY MAP No. _____

LOTS 7 & 8, SAUK JUNCTION, AS RECORDED IN VOLUME 57-078A OF PLATS, ON PAGES 304-306, AS DOCUMENT NUMBER 2871526, DANE COUNTY REGISTRY, LOCATED IN THE NE 1/4-NE 1/4 OF SECTION 22, TOWNSHIP 07 NORTH, RANGE 08 EAST, CITY OF MADISON, DANE COUNTY, WISCONSIN.



BEARINGS ARE BASED UPON THE WISCONSIN COUNTY COORDINATE SYSTEM, DANE COUNTY, THE NORTH LINE OF THE NE 1/4 OF SECTION 22-07-08 MEASURED AS BEARING S89°36'17"W

DETAIL

EXISTING 20'x20' SWITCHING STATION EASEMENT TO MID-PLAINS TELEPHONE, D/B/A TDS TELECOM, #3536438 (SCALE: 1"=20')

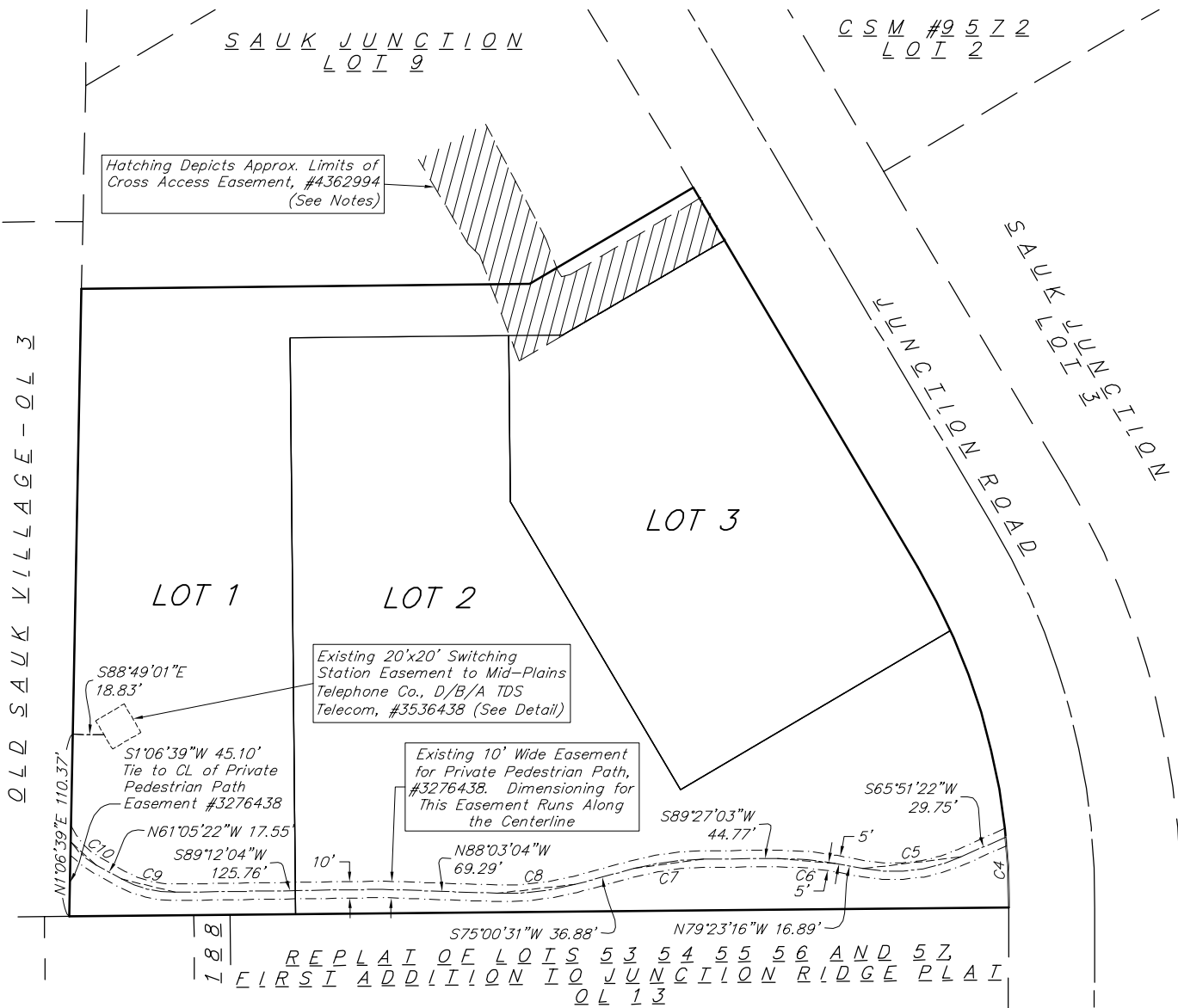
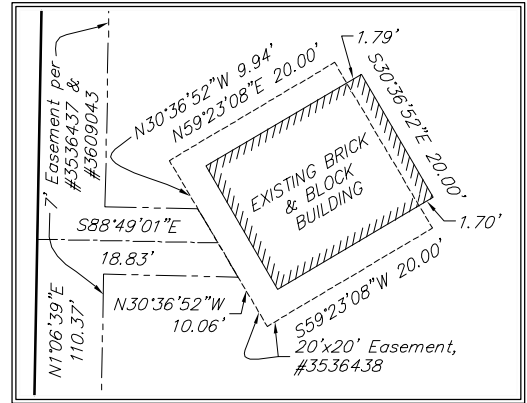

EXISTING EASEMENTS DETAIL

05 Aug 2015 - 10:30a M:\LZ Ventures\150054_510 Junction Road\CADD\150054_CSM.dwg by: mmcr

vierbicher
planners | engineers | advisors



REEDSBURG - MADISON - PRAIRIE DU CHIEN
999 Fourier Drive, Suite 201 Madison, Wisconsin 53717
Phone: (608) 824-0532 Fax: (608) 824-0530

FN: 150054
DATE: 08/05/2015
REV:
Drafted By: MMAR
Checked By: PKNU

SURVEYED FOR:
LZ Ventures, LLC
5603 Surrey Lane
Waunakee, WI 53597

C.S.M. No. _____
Doc. No. _____
Vol. _____ Page _____

SHEET
3 OF 9

CERTIFIED SURVEY MAP No. _____

LOTS 7 & 8, SAUK JUNCTION, AS RECORDED IN VOLUME 57-078A OF PLATS, ON PAGES 304-306, AS DOCUMENT NUMBER 2871526, DANE COUNTY REGISTRY, LOCATED IN THE NE 1/4-NE 1/4 OF SECTION 22, TOWNSHIP 07 NORTH, RANGE 08 EAST, CITY OF MADISON, DANE COUNTY, WISCONSIN.



BEARINGS ARE BASED UPON THE WISCONSIN COUNTY COORDINATE SYSTEM, DANE COUNTY, THE NORTH LINE OF THE NE 1/4 OF SECTION 22-07-08 MEASURED AS BEARING S89°36'17"W

DETAIL
NEW SWITCHING STATION
EASEMENT FOR THE BENEFIT OF MID-PLAINS
TELEPHONE, D/B/A TDS TELECOM
(SCALE: 1"=20')

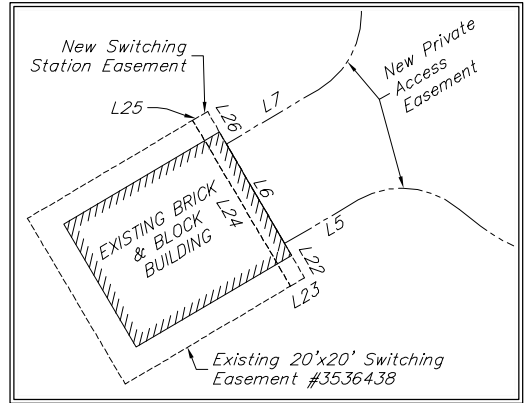

Hatching Depicts Limits of New Private Access Easement for the Benefit of all Lots Within This CSM and for the Benefit of Mid-Plains d/b/a TDS Telecom for Access to the Switching Station per Easement Recorded as #3536438. Said Easement Further for the Benefit of the City of Madison for Emergency Vehicular Access to all Lots Within This CSM.

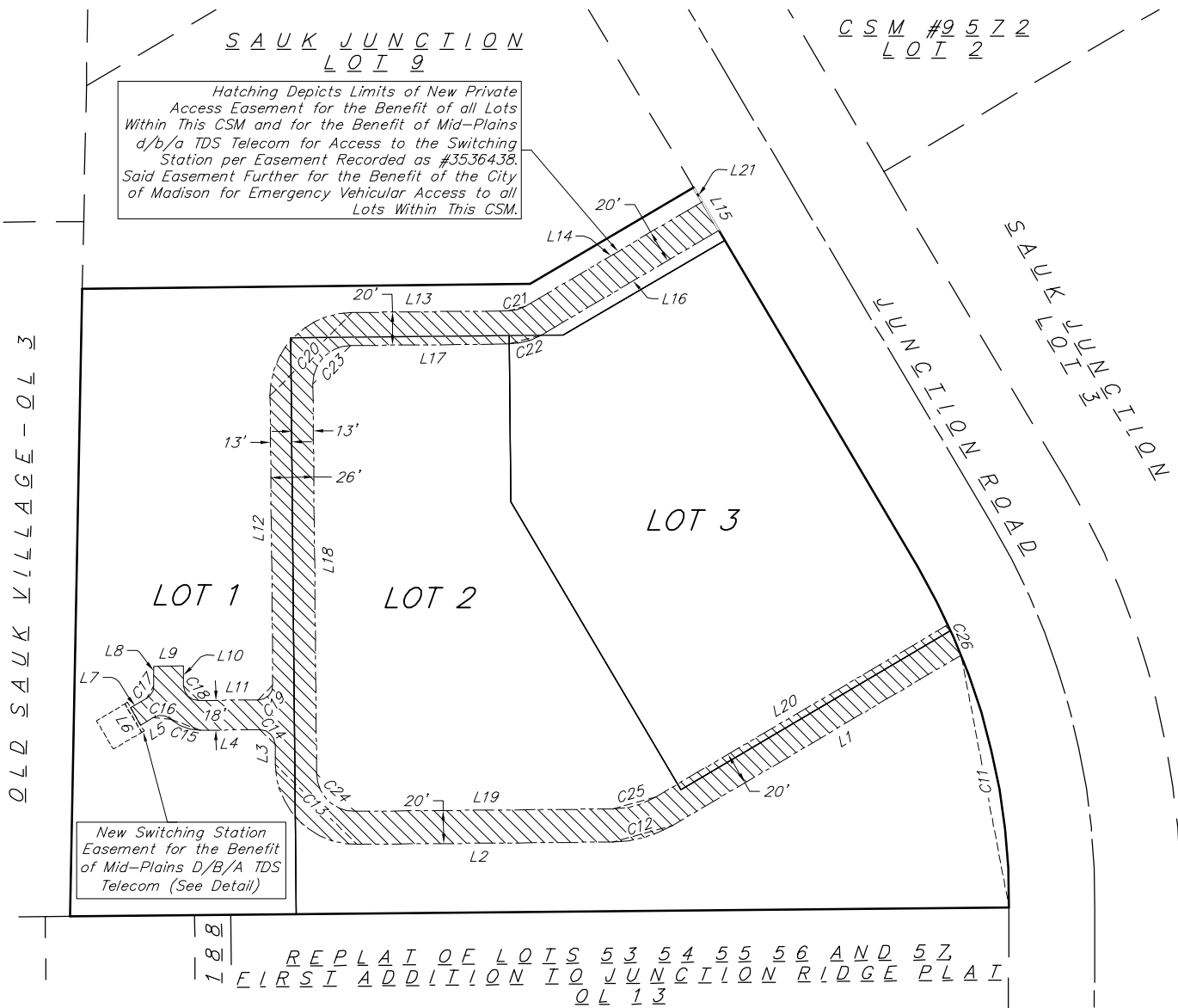

GRAPHIC SCALE FEET



NEW EASEMENTS DETAIL

05 Aug 2015 - 10:30a M:\LZ Ventures\150054_510 Junction Road\CADD\150054_CSM.dwg by: mmcr

vierbicher
planners | engineers | advisors



REEDSBURG - MADISON - PRAIRIE DU CHIEN
999 Fourier Drive, Suite 201 Madison, Wisconsin 53717
Phone: (608) 824-0532 Fax: (608) 824-0530

FN: 150054
DATE: 08/05/2015
REV:
Drafted By: MMAR
Checked By: PKNU

SURVEYED FOR:
LZ Ventures, LLC
5603 Surrey Lane
Waunakee, WI 53597

C.S.M. No. _____
Doc. No. _____
Vol. _____ Page _____

SHEET
4 OF 9

CERTIFIED SURVEY MAP No. _____

LOTS 7 & 8, SAUK JUNCTION, AS RECORDED IN VOLUME 57-078A OF PLATS, ON PAGES 304-306, AS DOCUMENT NUMBER 2871526, DANE COUNTY REGISTRY, LOCATED IN THE NE 1/4-NE 1/4 OF SECTION 22, TOWNSHIP 07 NORTH, RANGE 08 EAST, CITY OF MADISON, DANE COUNTY, WISCONSIN.



BEARINGS ARE BASED UPON THE WISCONSIN COUNTY COORDINATE SYSTEM, DANE COUNTY, THE NORTH LINE OF THE NE 1/4 OF SECTION 22-07-08 MEASURED AS BEARING S89°36'17"W

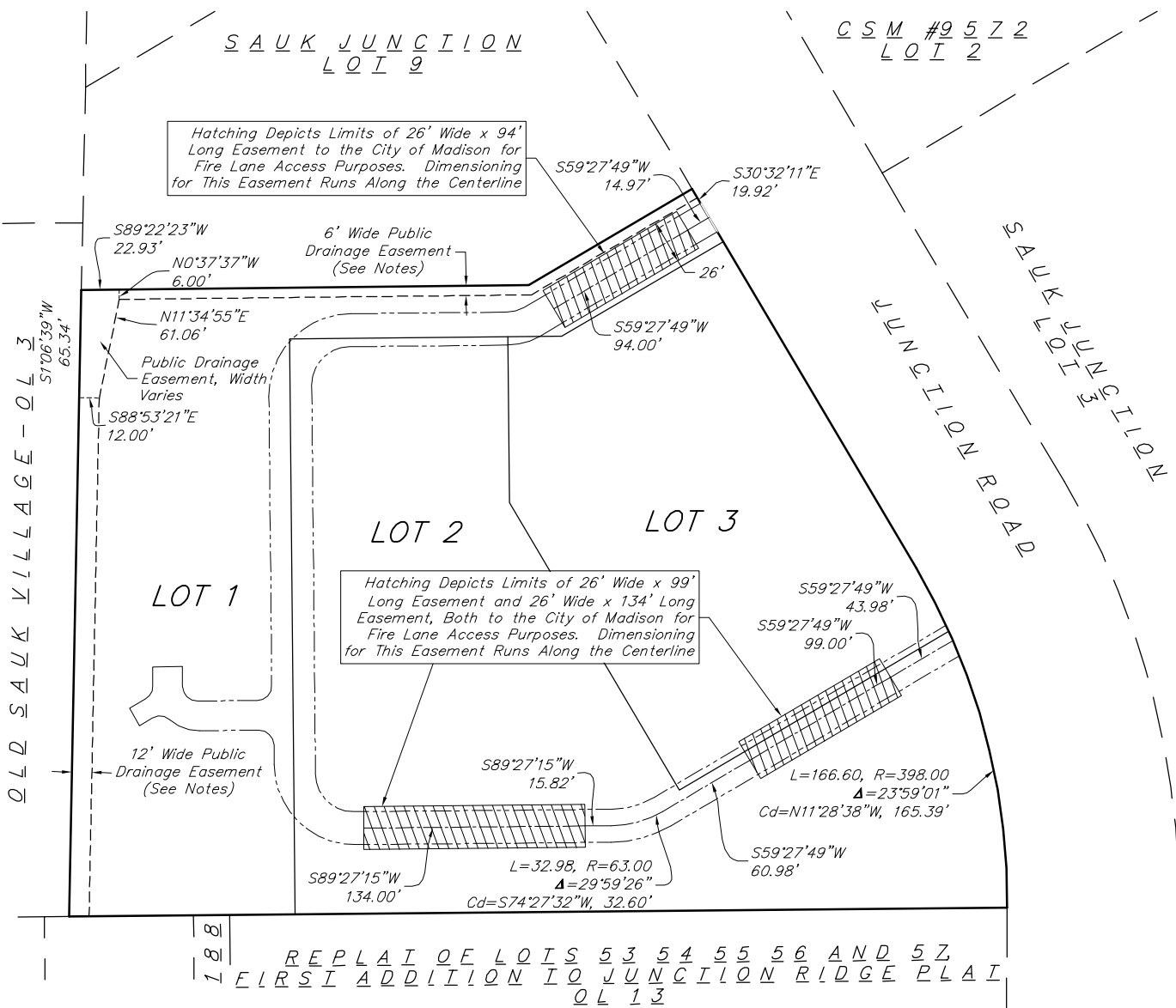

REPLAT OF LOTS 53 54 55 56 AND 57
FIRST ADDITION TO JUNCTION RIDGE PLAT
Q L 13

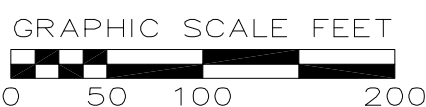

NEW EASEMENTS DETAIL

05 Aug 2015 - 10:37a M:\LZ Ventures\150054_510 Junction Road\CADD\150054_CSM.dwg by: mmcr

vierbicher planners engineers advisors REEDSBURG - MADISON - PRAIRIE DU CHIEN 999 Fourier Drive, Suite 201 Madison, Wisconsin 53717 Phone: (608) 826-0532 Fax: (608) 826-0530		FN: 150054 DATE: 08/05/2015	SURVEYED FOR: LZ Ventures, LLC 5603 Surrey Lane Waunakee, WI 53597	C.S.M. No. _____ Doc. No. _____ Vol. _____ Page _____	SHEET 5 OF 9
		REV: Drafted By: MMAR Checked By: PKNU			

CERTIFIED SURVEY MAP No. _____

LOTS 7 & 8, SAUK JUNCTION, AS RECORDED IN VOLUME 57-078A OF PLATS, ON PAGES 304-306, AS DOCUMENT NUMBER 2871526, DANE COUNTY REGISTRY, LOCATED IN THE NE 1/4-NE 1/4 OF SECTION 22, TOWNSHIP 07 NORTH, RANGE 08 EAST, CITY OF MADISON, DANE COUNTY, WISCONSIN.

Curve Table					
CURVE NUMBER	ARC LENGTH	RADIUS	DELTA	CHORD DIRECTION	CHORD LENGTH
C1	215.73'	398.00'	031°03'25"	S15°00'50"E	213.10'
C2	43.09'	398.00'	006°12'14"	S27°26'25"E	43.07'
C3	172.64'	398.00'	024°51'12"	S11°54'43"E	171.29'
C4	42.84'	398.00'	006°10'02"	N02°34'08"W	42.82'
C5	60.67'	100.00'	034°45'33"	S83°14'03"W	59.74'
C6	35.07'	180.00'	011°09'42"	N84°58'07"W	35.01'
C7	42.85'	170.00'	014°26'35"	S82°13'47"W	42.74'
C8	47.30'	160.00'	016°56'20"	S83°28'44"W	47.13'
C9	33.71'	65.00'	029°42'41"	N75°56'39"W	33.33'
C10	20.81'	45.00'	026°29'48"	N47°50'38"W	20.63'
C11	172.64'	398.00'	024°51'12"	N11°54'43"W	171.29'
C12	38.21'	73.00'	029°59'26"	S74°27'32"W	37.78'
C13	76.97'	49.00'	090°00'00"	N45°32'45"W	69.30'
C14	14.14'	9.00'	090°00'00"	N45°32'45"W	12.73'
C15	19.68'	27.00'	041°45'37"	N69°39'56"W	19.25'
C16	11.26'	9.00'	071°41'14"	N84°37'44"W	10.54'
C17	9.44'	9.00'	060°04'23"	N29°29'27"E	9.01'
C18	14.14'	9.00'	090°00'00"	S45°32'45"E	12.73'
C19	14.14'	9.00'	090°00'00"	N44°27'15"E	12.73'
C20	78.54'	50.00'	090°00'00"	N44°27'15"E	70.71'
C21	10.47'	20.00'	029°59'26"	N74°27'32"E	10.35'
C22	20.94'	40.00'	029°59'26"	S74°27'32"W	20.70'
C23	36.13'	23.00'	090°00'00"	S44°27'15"W	32.53'
C24	36.13'	23.00'	090°00'00"	S45°32'45"E	32.53'
C25	27.74'	53.00'	029°59'26"	N74°27'32"E	27.43'
C26	20.16'	398.00'	002°54'06"	S23°28'00"E	20.15'

Line Table		
LINE NO.	DIRECTION	LENGTH
L1	S59°27'49"W	202.59'
L2	S89°27'15"W	154.82'
L3	N00°32'45"W	12.00'
L4	S89°27'15"W	36.00'
L5	S59°31'38"W	8.93'
L6	N30°22'30"W	12.00'
L7	N59°31'38"E	11.15'
L8	N00°32'45"W	11.74'
L9	N89°27'15"E	18.00'
L10	S00°32'45"E	12.00'
L11	N89°27'15"E	36.00'
L12	N00°32'45"W	175.00'
L13	N89°27'15"E	94.80'
L14	N59°27'49"E	124.51'
L15	S30°32'11"E	20.00'
L16	S59°27'49"W	124.51'
L17	S89°27'15"W	95.80'
L18	S00°32'45"E	236.00'
L19	N89°27'15"E	155.82'
L20	N59°27'49"E	205.07'
L21	S30°32'11"E	9.92'
L22	S30°22'30"E	4.11'
L23	S59°23'08"W	1.70'
L24	N30°36'52"W	20.00'
L25	N59°23'08"E	1.79'
L26	S30°22'30"E	3.89'

RECORDED AS DATA AND TANGENT BEARING DATA					
CURVE NUMBER	ARC LENGTH	DELTA	CHORD DIRECTION	CHORD LENGTH	TANGENT BEARING
C1	(215.71')	(31°03'14")	(S15°24'29"E)	(213.08)	S00°30'53"W OUT

05 Aug 2015 - 10:30a M:\LZ Ventures\150054_510 Junction Road\CADD\150054_CSM.dwg by: mmarr

vierbicher
planners | engineers | advisors



REEDSBURG - MADISON - PRAIRIE DU CHIEN
999 Fourier Drive, Suite 201 Madison, Wisconsin 53717
Phone: (608) 824-0532 Fax: (608) 824-0530

FN: 150054
DATE: 08/05/2015
REV:
Drafted By: MMAR
Checked By: PKNU

SURVEYED FOR:
LZ Ventures, LLC
5603 Surrey Lane
Waunakee, WI 53597

C.S.M. No. _____
Doc. No. _____
Vol. _____ Page _____

SHEET
6 OF 9



CERTIFIED SURVEY MAP No. _____

LOTS 7 & 8, SAUK JUNCTION, AS RECORDED IN VOLUME 57-078A OF PLATS, ON PAGES 304-306, AS DOCUMENT NUMBER 2871526, DANE COUNTY REGISTRY, LOCATED IN THE NE 1/4-NE 1/4 OF SECTION 22, TOWNSHIP 07 NORTH, RANGE 08 EAST, CITY OF MADISON, DANE COUNTY, WISCONSIN.

NOTES:

1. All lots created by this Certified Survey Map are individually responsible for compliance with Chapter 37 of the Madison General Ordinances in regard to storm water management at the time they develop.
2. No changes in drainage patterns associated with development on any or all lots within this CSM shall be allowed without prior approval of the City Engineer.
3. Distances are ground and are measured to the nearest hundredth of a foot (0.01').
4. The boundary for this Certified Survey Map is based upon a Plat of Survey prepared by Vierbicher Associates, Inc., drawing number S-604, dated August 3, 2015 and on file with the Dane County Surveyor's Office.
5. Public Drainage Easements: No buildings, driveways, or retaining walls shall be placed in any easement for drainage purposes without written consent from the City of Madison Engineering Department. Fences may be placed in the easement only if they do not impede the anticipated flow of water. NOTE: In the event of a City of Madison Plan Commission and/or Common Council approved re-division of a previously subdivided property, the underlying public easements for drainage purposes are released and replaced by those required and created by the current approved subdivision.
6. Lots within this CSM are inter-dependent upon one another for storm water runoff conveyance. An Agreement providing for rights and responsibilities of Lot owners with regard to said storm water runoff conveyance shall be recorded subsequent to the recording of this CSM.
7. Notes per Sauk Junction Plat pertaining to this CSM:
 - 7.1. Access to all lots shall be generally consistent with the approved general development plan, coordinated, and limited to no more than four driveways along each side of Junction Road, unless otherwise determined by the Traffic Engineer. Joint or cross access easements between the lots may be required.
 - 7.2. No poles or buried cable are to be placed such that installation would disturb any survey stake or obstruct vision along any lot line or street line. The disturbance of a survey stake by anyone is a violation of Section 236.32 of Wisconsin Statutes. Utility Easements as herein set forth are for the use of Public Bodies and Private Public Utilities having the right to serve the area.
 - 7.3. If any land within this plat is rezoned to residential, then refer to Document No. 2624951.
 - 7.4. This plat and G.D.P. must meet highway noise land use provisions of Chapter 16, M.G.O.
8. Subject to PUD/GDP recorded as Document #2838850.
9. Subject to Alteration to an Approved and Recorded General Development Plan recorded as Document #2877393.
10. Subject to Declaration of Conditions and Covenants Sauk Junction recorded as Document #2960895.
11. Subject to Declaration of Conditions and Covenants for Plat of Sauk Junction recorded as Document #2967300.
12. Subject to Declaration of Conditions and Covenants for Plat of Sauk Junction recorded as Document #2967301.
13. Subject to Declaration of Private Easement for Pedestrian Path Purposes recorded as Document #3276438.
14. Subject to Easement to Wisconsin Power and Light Company recorded as Document #3359543.
15. Subject to PUD/SIP Sauk Junction recorded as Document #3269466.
16. Subject to Alteration to an Approved & Recorded Specific Implementation Plan recorded as Document #3428070.
17. Subject to Alteration to an Approved & Recorded Specific Implementation Plan recorded as Document #3536436.
18. Subject to Alteration to an Approved & Recorded Specific Implementation Plan recorded as Document #3588418.
19. Subject to Alteration to an Approved & Recorded Specific Implementation Plan recorded as Document #4010696.
20. Subject to Easement to Mid-Plains Telephone Co., d/b/a TDS Telecom recorded as Document #3536437. The 12' ingress/egress utility easement referenced in this document has been released by an instrument recorded as Document # _____, therefore said 12' ingress/egress utility easement has not been shown hereon. A new private access easement for the benefit of Mid-Plains Telephone Co., d/b/a TDS Telecom, and others has been granted as shown on Sheet 4 of this CSM.
21. Subject to Easement to Mid-Plains Telephone Co., d/b/a TDS Telecom recorded as Document #3536438. A new switching station easement for the benefit of Mid-Plains Telephone Co., d/b/a TDS Telecom has been granted as shown on Sheet 4 of this CSM and is intended to incorporate that part of the existing brick & block building lying outside of the existing 20'x20' switching station easement recorded as Document # 3536438.
22. Subject to Easement to Wisconsin Power and Light Company recorded as Document #3609043.
23. Lots within this CSM are subject to Cross Access Easement Agreement recorded as Document #4362994. The location of easement areas within this document are generally defined in exhibit maps depicting proposed conditions. The location of the easement as shown hereon is approximate and is based upon the field located edge of traveled way.
24. Subject to Public Storm Sewer Easement recorded as Document #4759513.
25. Subject to First Amendment to Easement recorded as Document #4813094.

05 Aug 2015 - 10:30a M:\LZ Ventures\150054_510 Junction Road\CADD\150054_CSM.dwg by: mmar

 <p>vierbicher planners engineers advisors</p> <p style="font-size: small;">REEDSBURG - MADISON - PRAIRIE DU CHIEN 999 Fourier Drive, Suite 201 Madison, Wisconsin 53717 Phone: (608) 824-0532 Fax: (608) 824-0530</p>		FN: 150054 DATE: 08/05/2015 REV: Drafted By: MMAR Checked By: PKNU	SURVEYED FOR: LZ Ventures, LLC 5603 Surrey Lane Waunakee, WI 53597	C.S.M. No. _____ Doc. No. _____ Vol. _____ Page _____	SHEET 7 OF 9
---	---	--	---	---	-----------------

CERTIFIED SURVEY MAP No. _____

LOTS 7 & 8, SAUK JUNCTION, AS RECORDED IN VOLUME 57-078A OF PLATS, ON PAGES 304-306, AS DOCUMENT NUMBER 2871526, DANE COUNTY REGISTRY, LOCATED IN THE NE 1/4-NE 1/4 OF SECTION 22, TOWNSHIP 07 NORTH, RANGE 08 EAST, CITY OF MADISON, DANE COUNTY, WISCONSIN.

SURVEYOR'S CERTIFICATE:

I, Michael S. Marty, Professional Land Surveyor No. 2452, hereby certify: That in full compliance with the provisions of Chapter 236.34 of the Wisconsin Statutes and the subdivision regulations of the City of Madison, and under the direction of LZ Ventures LLC., owner of said land, I have surveyed, divided and mapped this Certified Survey Map; that such Certified Survey Map correctly represents all exterior boundaries and the subdivision of the land surveyed; and that this land is described as Lots Seven (7) and Eight (8), Sauk Junction, as recorded in Volume 57-078A of Plats, on Pages 304-306, as Document Number 2871526, Dane County Registry, located in the NE 1/4-NE 1/4 of Section 22, Township 07 North, Range 08 East, City of Madison, Dane County, Wisconsin. Said description contains 196,384 square feet or 4.508 acres more or less.

Vierbicher Associates, Inc.
By: Michael S. Marty, P.L.S. No. 2452

Dated this _____ day of _____, 201__.

Signed: _____
Vierbicher Associates, Inc.
Michael S. Marty, P.L.S. No. 2452

OWNER'S CERTIFICATE OF DEDICATION:

LZ Ventures, LLC, as owner, does hereby certify that we caused the land described on this Certified Survey Map to be surveyed, divided, mapped, and dedicated as represented hereon. LZ Ventures, LLC, does further certify that this Certified Survey Map is required by S.236.34 of the State Statutes to be submitted to the City of Madison for approval or objection:

IN WITNESS WHEREOF, the said LZ Ventures, LLC, has caused these presents to be signed by John Leja, its _____, at Madison, Wisconsin, and its company seal to be hereunto affixed on this _____ day of _____, 20__.

LZ Ventures, LLC

LZ Ventures, LLC
by: John Leja,

STATE OF WISCONSIN)
DANE COUNTY) SS

Personally came before me this _____ day of _____, 20__, the above named John Leja, _____, to me known to be the person who executed the foregoing instrument and acknowledged the same.

Notary Public

My Commission Expires/is Permanent: _____

05 Aug 2015 - 10:30a M:\LZ Ventures\150054_510 Junction Road\CADD\150054_CSM.dwg by: mmcr

vierbicher
planners | engineers | advisors



REEDSBURG - MADISON - PRAIRIE DU CHIEN
999 Fourier Drive, Suite 201 Madison, Wisconsin 53717
Phone: (608) 826-0532 Fax: (608) 826-0530

FN: 150054
DATE: 08/05/2015
REV:
Drafted By: MMAR
Checked By: PKNU

SURVEYED FOR:
LZ Ventures, LLC
5603 Surrey Lane
Waunakee, WI 53597

C.S.M. No. _____
Doc. No. _____
Vol. _____ Page _____

**SHEET
8 OF 9**

CERTIFIED SURVEY MAP No. _____

LOTS 7 & 8, SAUK JUNCTION, AS RECORDED IN VOLUME 57-078A OF PLATS, ON PAGES 304-306, AS DOCUMENT NUMBER 2871526, DANE COUNTY REGISTRY, LOCATED IN THE NE 1/4-NE 1/4 OF SECTION 22, TOWNSHIP 07 NORTH, RANGE 08 EAST, CITY OF MADISON, DANE COUNTY, WISCONSIN.

CONSENT OF MORTGAGEE CERTIFICATE:

_____, a banking association duly organized and existing under and by virtue of the laws of the State of Wisconsin, mortgagee of the above-described land, does hereby consent to the surveying, dividing, mapping and dedicating of the land described on this Certified Survey Map, and does hereby consent to the above Owner's Certificates.

IN WITNESS WHEREOF, the said _____ has caused these presents to be signed by _____, its _____, at Madison, Wisconsin, on this _____ day of _____, 20__.

Signed: _____

State of Wisconsin)
) SS
 County of Dane)

Personally came before me this _____ day of _____, 20__, _____ of the above named banking association,

and acknowledged that they executed the foregoing instrument as such officer of the deed of said banking association.

Notary Public: _____

My commission expires/is permanent: _____

MADISON COMMON COUNCIL CERTIFICATE:

Resolved that this Certified Survey Map located in the City of Madison was hereby approved by Enactment Number _____, File ID Number _____, adopted on the _____ day of _____, 201__; that said enactment provided for the acceptance of those lands dedicated and rights conveyed by said Certified Survey Map to the City of Madison for public use.

Dated this _____ day of _____, 201__.

Signed: _____
 Maribeth Witzel-Behl, City Clerk, City of Madison
 Dane County, Wisconsin

MADISON PLAN COMMISSION CERTIFICATE:

Approved for recording per the City of Madison Plan Commission.

Dated this _____ day of _____, 201__.

Signed: _____
 Natalie Erdman, Secretary
 City of Madison Plan Commission

REGISTER OF DEEDS CERTIFICATE:

Received for recording on this _____ day of _____, 201__, at _____ o'clock __.m., and recorded in Volume _____ of Certified Survey Maps on pages _____, as Document Number _____.

 Kristi Chlebowski, Dane County Register of Deeds

05 Aug 2015 - 10:31a M:\LZ Ventures\150054_510 Junction Road\CADD\150054_CSM.dwg by: mmcr

