

RIGHT SHOULDER CONDITION

STA 11+25 TO STA 12+70
STA 14+60 TO STA 15+50
STA 18+00 TO STA 18+75

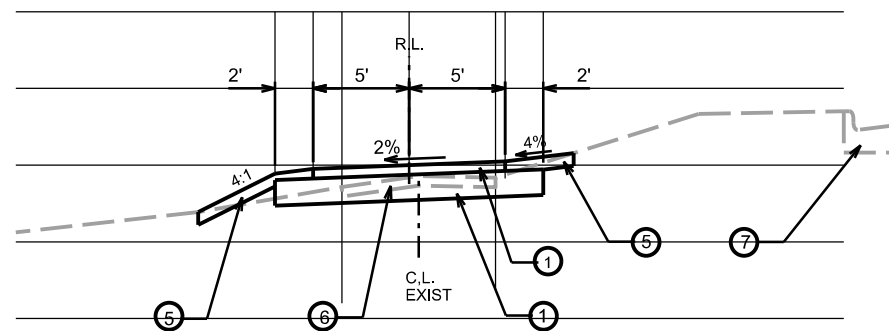

PROPOSED TYPICAL SECTION

TENNEY PATH STA 10+62 TO STA 12+70
TENNEY PATH STA 14+60 TO STA 16+35
TENNEY PATH STA 17+90 TO STA 19+75

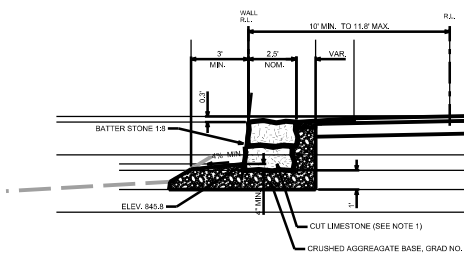

**PROPOSED TYPICAL SECTION
LIMESTONE PLACEMENT**

TENNEY PATH STA 12+70 TO STA 14+60
TENNEY PATH STA 16+35 TO STA 17+90

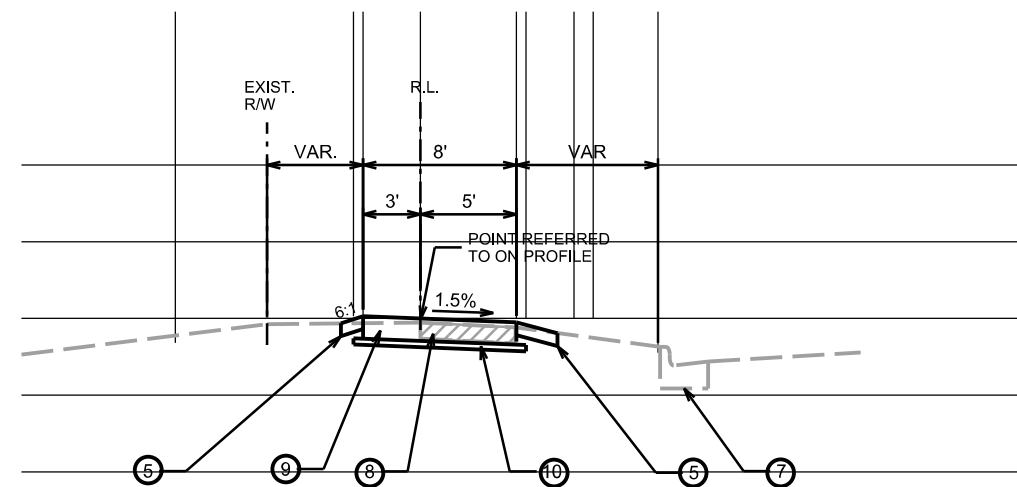

PROPOSED TYPICAL SECTION

E. JOHNSON SIDEWALK STA 7+90 TO STA 10+10

LEGEND

- ① 3" HMA PAVEMENT (NOTE 1)
- ② 8" CRUSHED AGGREGATE BASE COURSE (GRAD. NO. 2)
- ③ CUT LIMESTONE SHORELINE PROTECTION (SEE DETAIL)
- ④ CRUSHED AGGREGATE BASE GRAD. NO. 1 (3" CLEAR)
- ⑤ 4-INCH MIN. TOPSOIL, SEED AND MATTING
- ⑥ REMOVE EXIST. ASPHALT PATH (EXCAVATION CUT)
- ⑦ EXISTING CONCRETE CURB TO REMAIN
- ⑧ REMOVE EXISTING CONCRETE SIDEWALK
- ⑨ 7-INCH CONCRETE SIDEWALK
- ⑩ 2" GRANULAR FILL (INCIDENTAL)

NOTES:

1. WHERE DITCH ELEVATIONS NOT SHOWN ON CROSS SECTIONS OFFSET TO DITCH IS 2' AND FLOW LINE ELEVATION IS 0.5' BELOW SHOULDER POINT.
2. FILL SLOPES FOR MAIN PATH ARE 4:1 UNLESS OTHERWISE SHOWN ON ON CROSS SECTIONS.

PLOT SCALE: _____

PLOT NAME: _____

REV. DATE: _____

ORIGINATOR: CITY OF MADISON, STREETS DIVISION