

**VARIANCE FEES**

MGO \$50.00  
COMM \$490.00  
Priority – Double above

**PETITION FOR VARIANCE APPLICATION**

City of Madison  
Building Inspection  
Division

126 S. Hamilton St.  
Madison, WI 53703  
(608) 266-4568

Amount Paid 490.00

Name of Owner	Project Description Madison Municipal Building Renovation	Agent, architect, or engineering firm MEP Associates, LLC
Company (if applies)		No. & Street 860 Blue Gentian Road, Suite 175
No. & Street	Tenant name (if any) The City of Madison	City, State, Zip Code Eagan, Minnesota 55121
City, State, Zip Code	Building Address 215 Martin Luther King Jr. Blvd	Phone 651-379-9120
Phone	Madison, Wisconsin 53703	Name of Contact Person Randall A. Jacobs, PE
e-mail		e-mail randyj@mepassociates.com

1. The rule being petitioned reads as follows: (Cite the specific rule number and language. Also, indicate the nonconforming conditions for your project.) 2009 IMC section 607.3.3.2.1: 1. Where a smoke damper is installed within a duct, a smoke detector shall be installed in the duct within 5 ft of the damper with no air outlets or inlets between the detector and the damper. The detector shall be listed for the air velocity, temp., and humidity anticipated at the point where it is installed. Other than in mech smoke control systems, dampers shall be closed upon fan shutdown where the local smoke detectors require a min velocity to operate.

2. The rule being petitioned cannot be entirely satisfied because: Smoke dampers located in ducts that pass from the third floor to the attic have limited access to the damper locations, and to place the duct smoke detector within 5 ft of the damper also places it in a location with limited access. This limited access is a nuisance related to annual testing of the smoke damper.

3. The following alternatives and supporting information are proposed as a means of providing an equivalent degree of health, safety, and welfare as addressed by the rule: We have two situations, first where two smoke dampers are in series. In this situation we propose extending the 5ft distance between the damper and the duct smoke detector allowing one duct smoke detector to control both dampers. The second situation is where we have a single damper controlled by multiple down stream duct smoke detectors. If any of the downstream dampers/detectors sense smoke the upstream damper will also close resulting in no migration of smoke and the entire system losing service instead of just a portion of the system.

See the attached description and drawings AHU-3-SA, AHU-3-RA, AHU-3-EA/OA, AHU-4-SA, AHU-4-RA, and AHU-4-EA/OA

Note: Please attach any pictures, plans, or required position statements.

**VERIFICATION BY OWNER – PETITION IS VALID ONLY IF NOTARIZED AND ACCOMPANIED BY A REVIEW FEE AND ANY REQUIRED POSITION STATEMENTS.**

Note: Petitioner must be the owner of the building. Tenants, agents, contractors, attorneys, etc. may not sign the petition unless a Power of Attorney is submitted with the Petition for Variance Application.

ROBERT PHILLIPS, being duly sworn, I state as petitioner that I have read the foregoing  
Print name of owner

petition, that I believe it to be true, and I have significant ownership rights in the subject building or project.

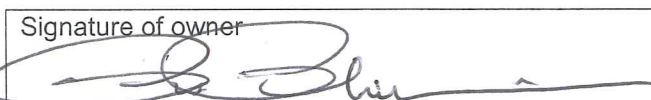
Signature of owner 	Subscribed and sworn to before me this date: <u>7/3/2019</u>
Notary public <u>Johanna L. Johnson</u>	My commission expires: <u>1/8/2022</u>

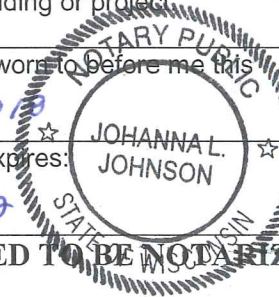

**NOTE: ONLY VARIANCES FOR COMMERCIAL CODES ARE REQUIRED TO BE NOTARIZED.**



June 21, 2018

City of Madison Building Inspection Division  
126 S. Hamilton Street  
Madison, Wisconsin 53703

RE: Madison Municipal Building Fire Smoke Damper Control – Variance; MEP Project No.: M10.15.02

To Whom it may concern:

The 2009 IMC section 609.7.3.3.2 gives a few options for control of smoke dampers; the applicable option for the installation in the Madison Municipal Building (MMB) is having a duct smoke detector within 5 feet of the damper with no duct branches between the damper and the detector. The code does not specify a side of the damper that this detector should be located, so it may be installed upstream or downstream from the direction of air flow. MEP Associates (MEP) believes the intent of this detector location is to eliminate smoke from migrating between floors or smoke compartments. The purpose of this variance request is to allow the distance between the damper and the detector exceed the 5-foot limit and to allow one damper to be controlled by multiple detectors.

For the MMB project, there are two situations that meet this original intent. First, is the situation where a single duct has two dampers in series with no take-offs in-between. This is the case in the following locations (FSD=Fire Smoke Damper, DSD=Duct Smoke Detector):

1. AHU-3 Supply Air FSD-30 being controlled by the same signal as FSD-37/DSD67.
2. AHU-3 Return Air FSD-28 being controlled by the same signal as FSD-39/DSD69.
3. AHU-4 Return Air FSD-35 being controlled by the same signal as FSD-47/DSD77.

Second, is the situation where a single damper is controlled by multiple detectors located at opposite ends of the duct run. In this case, the single damper will close if any of the other dampers are called to close. This is the case in the following locations that have been identified by Electric Construction:

1. AHU-3 Supply Air FSD-32 shall close if either FSD-41/DSD71, FSD-42/DSD72, or FSD-22/DSD52 are closed.
2. AHU-3 Return Air FSD-31 shall close if either FSD-43/DSD73, FSD-72/DSD102, or FSD-23/DSD53 are closed.
3. AHU3 Exhaust Air FSD-29 shall close if either FSD-40/DSD70, FSD-38/DSD68, or FSD-21/51 are closed.
4. AHU-4 Supply Air FSD-33 shall close if either FSD-73/DSD103, FSD-45/DSD75, or FSD-25/DSD55 are closed.
5. AHU-4 Supply Air FSD-36 shall close if either FSD-46/DSD76 or FSD-26/DSD56 are closed.
6. AHU-4 Return Air FSD-71 shall close if either FSD-44/DSD74 or FSD-24/DSD54 are closed.
7. AHU-4 Exhaust Air FSD-34 shall close if either FSD-48/DSD78 or FSD-27/DSD57 are closed.

See attached diagrams AHU-3-SA, AHU-3-RA, AHU-3-EA/OA, AHU-4-SA, AHU-4-RA, and AHU-4-EA/OA.

Sincerely,  
MEP ASSOCIATES, LLC



Randall A. Jacobs, PE, LC, LEED AP  
Sr. Electrical Engineer



Larry Nemer, PE, LEED AP  
Principal, Sr. Mechanical Engineer,  
Operations Manager-Twin Cities

c: MEP File

## City of Madison Fire Department Position Statement

<b>Owner:</b> City of Madison Mike Schuchardt –City Engineering	<b>Project Name:</b> Madison Municipal Building	<b>Contact:</b> Randall A Jacobs MEP Associates, LLC
<b>Address:</b> 210 Martin Luther King Jr Blvd Madison, WI 53703	<b>Building Location:</b> 215 Martin Luther King Jr Blvd Madison, WI 53703	<b>Address:</b> 860 Blue Gentian Road Suite 175 Eagan, MN 55121
<b>Owner Phone:</b> (608) 261-9249 <b>Email:</b> mschuchardt@cityofmadison.com	<b>Building Occupancy or Use:</b> Group B Office	<b>Phone:</b> 651-379-9120 <b>Email:</b> randyj@mepassociates.com

**Rule Being Petitioned: IMC 607.3.3.2.1.1.**

**I have read the application for variance and recommend:** (check appropriate box)

Approval     
  **Conditional Approval**     
  Denial     
  No Comment

- Duct detectors and their placement shall comply with NFPA 90A & NFPA 72,
- A minimum of (1) duct detector shall be installed for each smoke damper unless allowed by NFPA 90A.
- MFD will support distances greater than 5-ft where installation/access is difficult within reason provided all other elements of the fire/smoke dampers and the location of inlets/outlets conform to the IMC, NFPA 90A & NFPA 72.

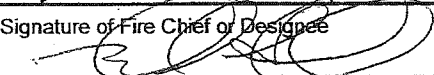
Name of Fire Chief or Designee (type or print) <b>Bill Sullivan, Fire Protection Engineer</b>	
City of Madison Fire Department	Telephone Number <b>608-261-9658</b>
Signature of Fire Chief or Designee 	Date Signed <b>July 2, 2018</b>



## City of Madison Fire Department Position Statement

<b>Owner:</b> City of Madison Mike Schuchardt –City Engineering	<b>Project Name:</b> Madison Municipal Building	<b>Contact:</b> Randall A Jacobs MEP Associates, LLC
<b>Address:</b> 210 Martin Luther King Jr Blvd Madison, WI 53703	<b>Building Location:</b> 215 Martin Luther King Jr Blvd Madison, WI 53703	<b>Address:</b> 860 Blue Gentian Road Suite 175 Eagan, MN 55121
<b>Owner Phone:</b> (608) 261-9249 <b>Email:</b> mschuchardt@cityofmadison.com	<b>Building Occupancy or Use:</b> Group B Office	<b>Phone:</b> 651-379-9120 <b>Email:</b> randyj@mepassociates.com

**Rule Being Petitioned: IMC 607.3.3.2.1.1.**

**I have read the application for variance and recommend:** (check appropriate box)

Approval     
  **Conditional Approval**     
  Denial     
  No Comment

- Duct detectors and their placement shall comply with NFPA 90A & NFPA 72,
- A minimum of (1) duct detector shall be installed for each smoke damper unless allowed by NFPA 90A.
- MFD will support distances greater than 5-ft where installation/access is difficult within reason provided all other elements of the fire/smoke dampers and the location of inlets/outlets conform to the IMC, NFPA 90A & NFPA 72.

Name of Fire Chief or Designee (type or print) <b>Bill Sullivan, Fire Protection Engineer</b>	
City of Madison Fire Department	Telephone Number <b>608-261-9658</b>
Signature of Fire Chief or Designee 	Date Signed <b>July 2, 2018</b>

AHU-3 SUPPLY AIR

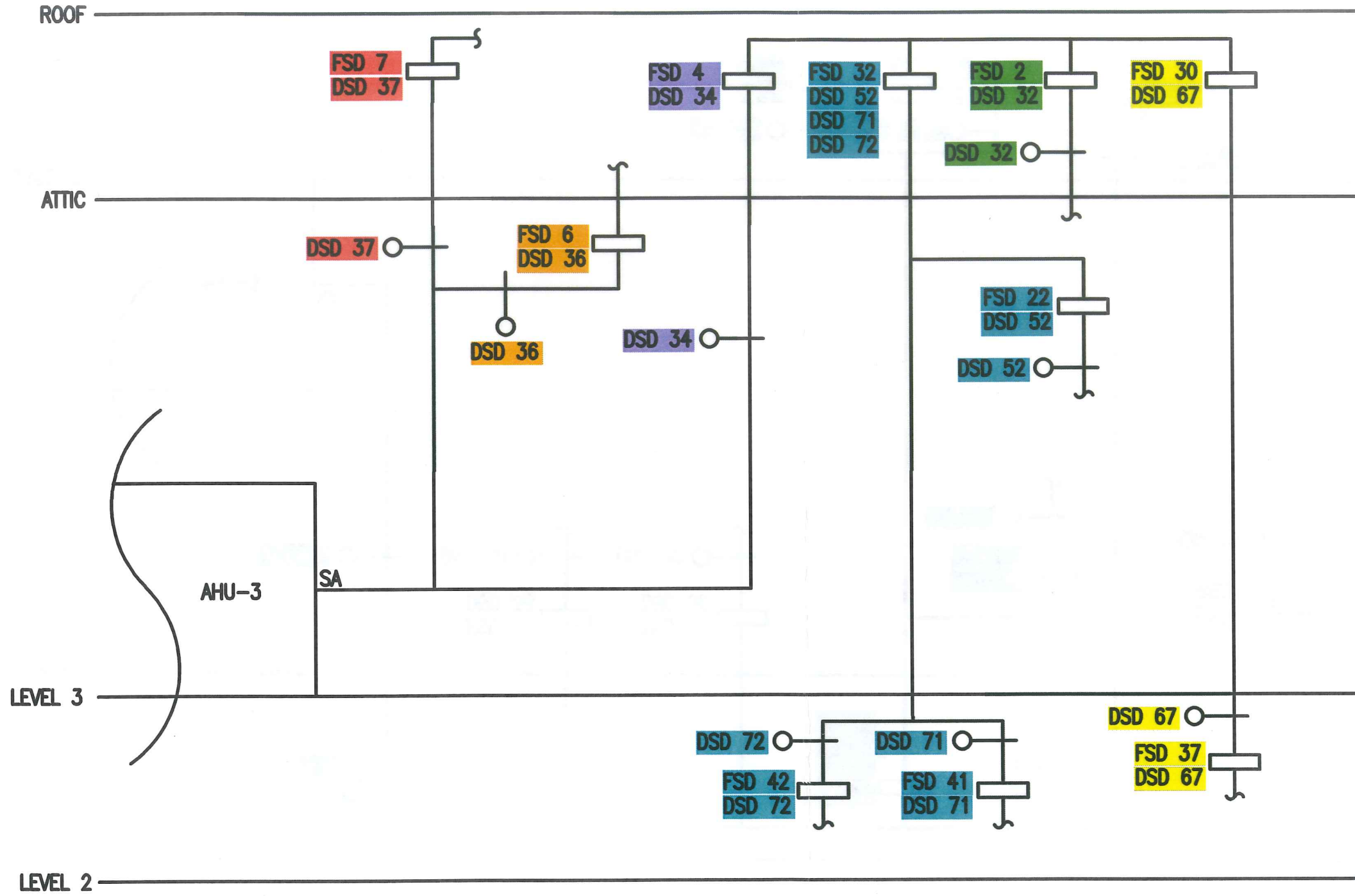

Sheet: AHU-3 SA  
Issue: Variance Request  
Date: 2018.06.20  
Project #: M10.15.02

MADISON MUNICIPAL BUILDING  
215 Martin Luther King, Jr. Blvd  
Madison, WI 53703



AHU-3 EXHAUST/OUTDOOR AIR

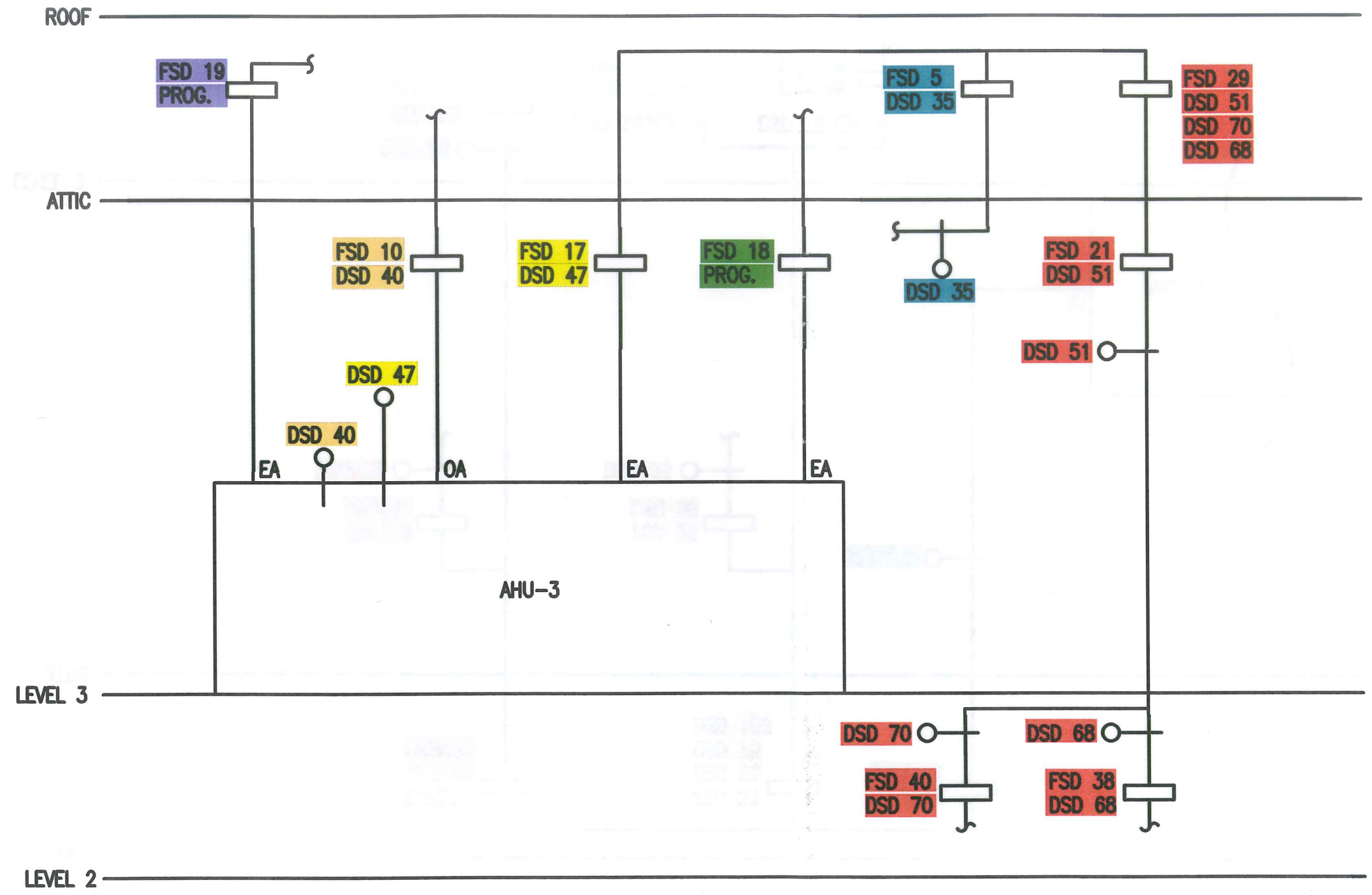

	Sheet: AHU-3 EA/OA Issue: Variance Request Date: 2018.06.20 Project #: M10.15.02
	MADISON MUNICIPAL BUILDING 215 Martin Luther King, Jr. Blvd Madison, WI 53703

AHU-4 RETURN AIR

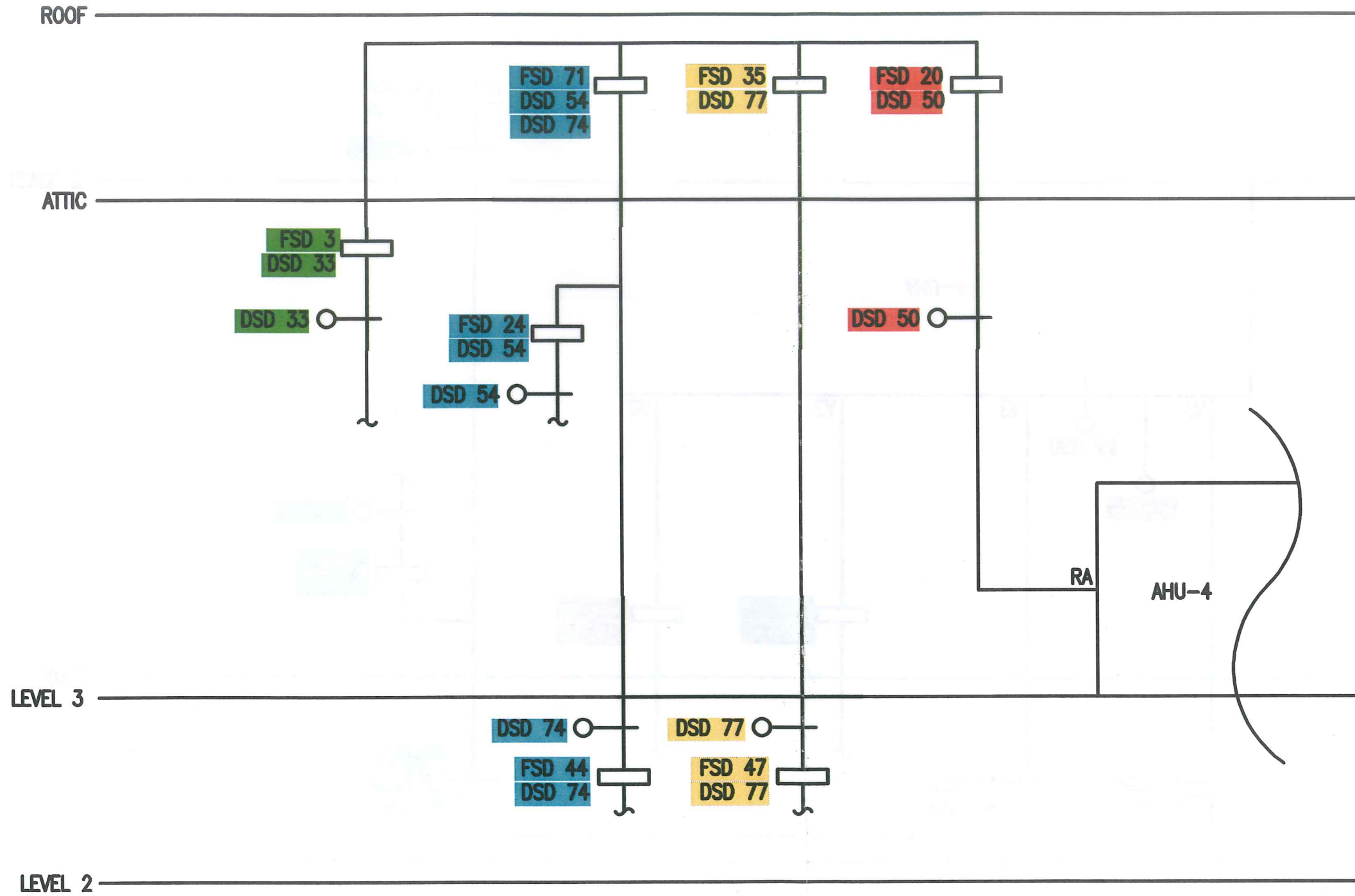

MADISON MUNICIPAL BUILDING

215 Martin Luther King, Jr. Blvd  
Madison, WI 53703

Sheet: AHU-4 RA  
Issue: Variance Request  
Date: 2018.06.20  
Project #: M10.15.02