

Momental at Elver Park

A semi-permanent sculpture commissioned by
Makeshift Festival



Contents

Introduction	2
Location.....	3
About Momental.....	4
Construction and Installation.....	5
Timeline.....	6
Events.....	7
Maintenance	8
Impact	8
Signage	9
Support.....	9

Introduction

Makeshift Festival, the annual food and art festival presented by the Madison Parks Foundation, creates an accessible visual and culinary art experience in one of Madison's public parks each year. As a one-day festival, the art comes and goes quickly. This year, Makeshift is growing one work of art in both size and duration by seeking semi-permanent placement in Elver Park.

Stage one of *Momenta* was funded by Madison Parks Foundation (MPF) and exhibition in Tenney Park for Makeshift Festival.



Location

After considering three Makeshift artworks for potential permanent placement, Makeshift/MPF decided to seek an Art in Public Places grant to fund the physical growth and semi-permanent placement of *Momental* at Elver Park. It will be located near the splash pad and roundabout in front of the pavilion.

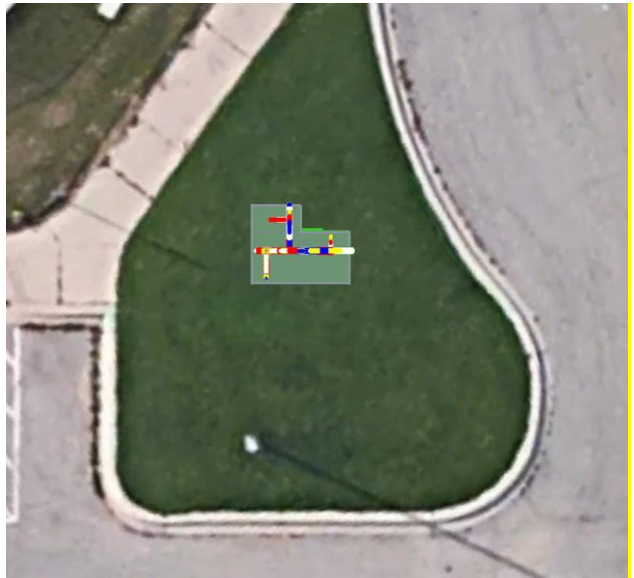
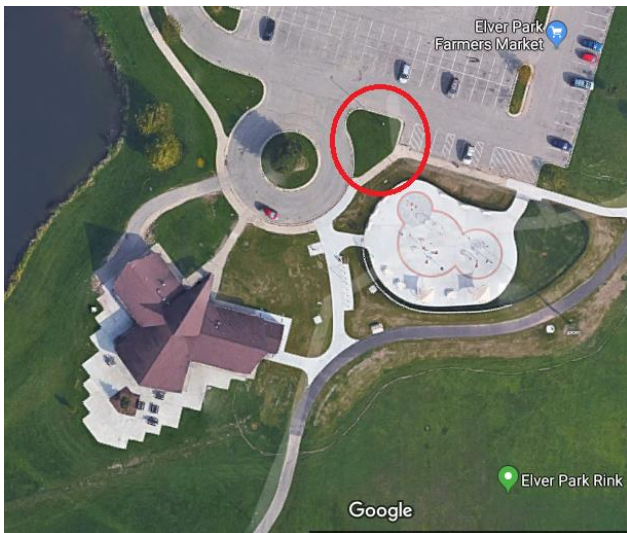

We are excited to present unique public art beyond downtown/isthmus neighborhoods and hope that *Momental* is the first of many Makeshift/MPF commissions to find a longer life in a public space after the festival ends in order to make interesting public art accessible to all.

About Momental

Jeff Repko's work is a complex system of assemblages that form a cohesive, playful composition. The components of the piece have an implied potential that can only be realized through interactions with one another. Pieces of varying sizes, shapes, and colors come together to create an intricate, beautiful assembly, much like people coming together in a park. These components, much like a community, inspire a continually changing process as they interact. Their main function is to co-exist together in a space, working together to create a monument to the transient nature of communities and the parks that are often a central hub for memories, interactions, and fun.

While monuments often exist to commemorate a fixed person or event, *Momental* celebrates the limitless potential of parks and communities to develop and change throughout time. Its abstract visual aesthetics allow viewers to attach their own meanings, rejecting identification of a specific time, era, or culture. It becomes a monument to growth and the potential in oneself to work with others. Sometimes, the way we work together is abstract and unclear, but Repko focuses on the importance of each individual connection rather than trying to understand it all at once. As many individual connections are experienced in parks, we couldn't think of a more ideal location to exhibit *Momental*.

Construction and Installation

Please see the accompanying stamped structural engineering report for full details.

In its construction, *Momental* is designed to assemble on or off site. It is made of Playboard, a durable, municipal materials often used in the construction of playgrounds. It is UV stable, easily cleaned, and exposable to harsh weather for a minimum of 10 years. Each piece of the exterior is planned and digitally fabricated, allowing for parts to be exchanged and replaced if needed. The parts are cataloged and can be replicated. The internal stainless-steel structure is designed to provide extra support and reinforcement for the plastic material skinning the exterior. Stainless steel hardware will be used to secure the Playboard pieces to each other and to the steel skeleton. Through the design, 90-95% of the Playboard sheets are used, by turning the remnants of most “scraps” into additional pieces. This creates unexpected outcomes while also enabling minimal waste which is important to the artist both ethically and conceptually as it brings unplanned interaction into the work – creating new possibilities.

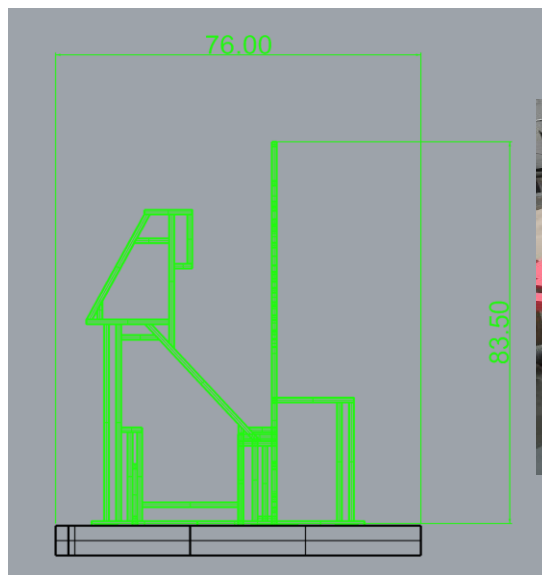
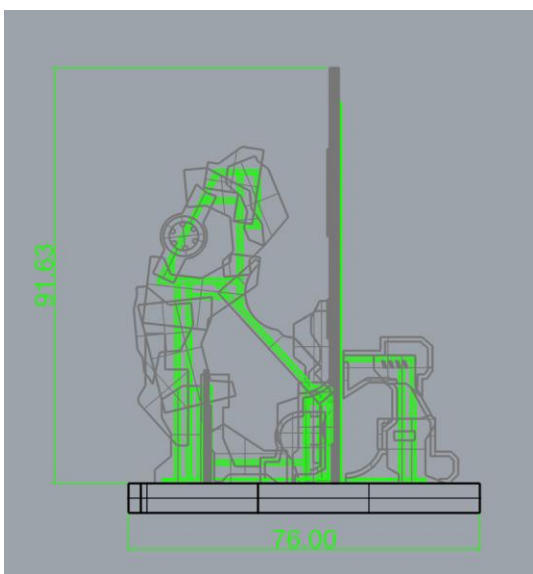
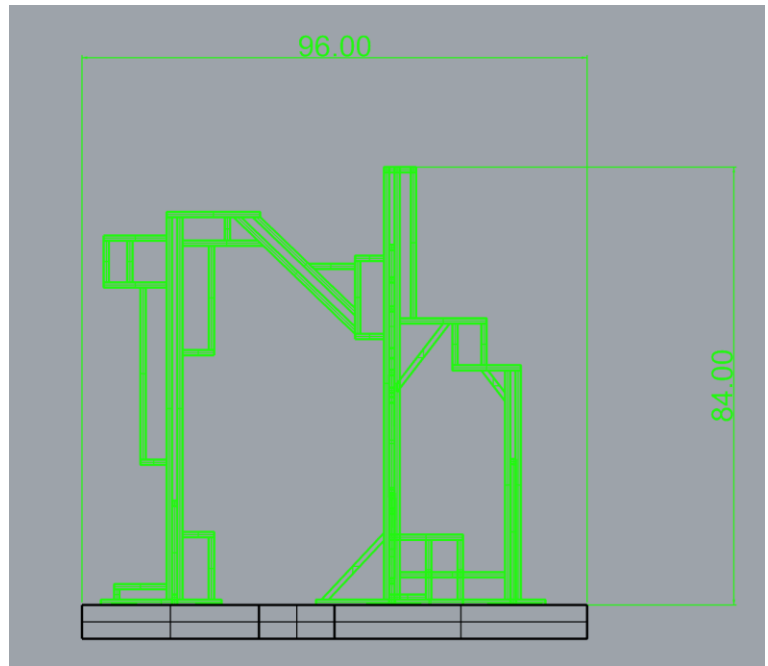
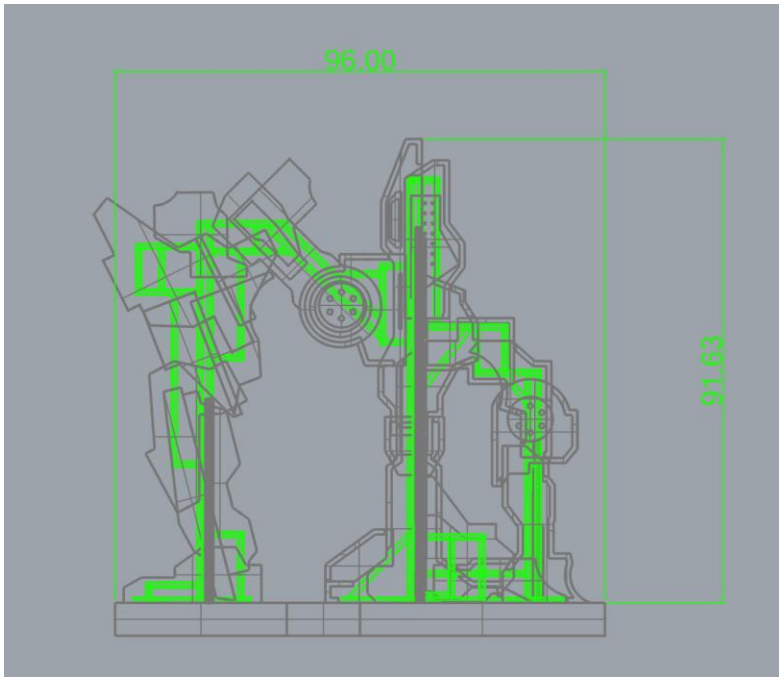

- The sculpture will be delivered artist in the week leading up to the unveiling event. (*Please see timeline on next page.*)
 - Once delivered, the artist and his team will place the internal framework of the sculpture on the cement pad.
 - It will be secured using 3/8 inch stainless metal tabs that will be welded to the metal frame during fabrication and Kwik Bolt TZ - SS 304 3/8" expansion anchors.
 - Holes will be drilled directly into cement pad using a rotary hammer.
 - The holes will be blown out using a blow-out pump and e anchors will dropped through the a hole in the metal tab and into the cement. Then tighten to expand and secure the sculpture.
- After the frame is secured to the cement pad, the artist will finish cladding the metal frame with the plastic exterior.
- The following equipment will be used for installation.
 - ❖ Equipment specified by structural engineer:
 - Suitable rotary hammer (drilling)
 - Properly sized drill bit (drilling)
 - Torque controlled cordless impact tool (setting anchors)
 - Torque wrench (setting anchors)
 - Hammer (setting anchors)
 - Manual blow-out pump (clean-up)
 - ❖ Additional equipment used by the artist
 - Shop Vac for clean up
 - Socket Wrench Set
 - Cordless Drill
 - Ladder
- After installation is complete, clean up consists of removal of any small plastic debris or loose hardware. There is minimal waste or scrap material to remove. Once clean the artist will collect all equipment and remove items from the site.

Timeline

Original Timeline (Given the recent damage throughout Madison due to flooding, we realize that most contractors will be over-extended, and this timeline may be unrealistic. Due to this, an alternative timeline is also provided.)

September 6, 2018: Order materials

September 7, 2018: Request estimates for cement pad from contractors and Parks Dept

September 12, 2018: Secure and schedule contractor

October 8-12, 2018: Target date range for cement pad installation

October 16-19, 2018: Target installation

The four-day window is to help prepare for inclement weather, though installation should only require two days.

- Day One: Estimated time frame 8 hrs
 - Delivery and install of metal frame by artist and his team.
 - Metal frame will be secured using 3/8 inch stainless metal tabs that will be welded to the metal frame during fabrication and Kwik Bolt TZ - SS 304 3/8" expansion anchors as specified by Echelon Structures engineering firm.
 - Holes will be drilled directly into cement pad using a rotary hammer.

- The holes will be blown out using a blow-out pump and e anchors will dropped through a hole in the metal tab and into the cement. Then tighten to expand and secure the sculpture.
 - Begin cladding metal frame with plastic exterior.
 - Each plastic piece will be bolted together and to the frame using 1/4" diameter bolts that vary in length.
 - Some parts will come pre-assemble while others will need to be assembled on site using a socket wrench and cordless drill.
- Day Two Estimate time frame 8 hrs
 - Double check and tighten hardware before applying caps to hardware.
 - Install hardware caps and signage
 - Clean area of any small plastic debris or loose hardware

October 20 or 21, 2018: Unveiling event

October 20, 2019 - 2026: Annual check in with Arts Administrator and Parks Superintendent and Parks Foundation Executive Director on state of the sculpture and status of endowment funds (held by MPF)

October 20, 2027: Arts Administrator, Parks Superintendent, and artist assess the state of the sculpture and prepare for deinstallation if necessary.

Alternative Timeline

September 6, 2018: Order materials

September 7 -12, 2018: Request estimates for cement pad from contractors and Parks Dept

Late fall: secure and schedule contractor

April 15 – 19, 2019: Alternative date range for cement pad install

April 22 – 26, 2019: Alternative installation (*see 2-day installation schedule above*)

April 27 or 28, 2019: Unveiling event

Annual check-in each year that follows.

Events

At the moment, we only plan on having an unveiling event on October 20th or 21st or April/May 2019. The event will be 2 hours in the afternoon with an artist talk, refreshments, and a small participatory project potentially in collaboration with the Art Cart.

Maintenance

A small fund will be established with the Madison Parks Foundation for maintenance and decommissioning expenses.

Each year, near the anniversary of the unveiling, Jeff Repko (artist) and/or Bethany Jurewicz (Project Manager) will initiate communications with the City of Madison Arts Administrator, City of Madison Parks Superintendent, and Madison Parks Foundation Executive Director to establish, in writing, the state of the sculpture and the fund, maintenance and/or repairs needed in the upcoming year, and any safety concerns, past or future. The Arts Administrator will oversee maintenance, repairs, and eventual decommission of the artwork in cooperation with the Madison Parks Foundation Executive Director, artist, and project manager. Details regarding execution and funding of maintenance, repairs, and decommission will be established via a Memorandum of Understanding between Makeshift/MPF and the Arts Administrator.

The sculpture is intended to remain installed at Elver Park for a minimum of ten years. During the anniversary check-in in the ninth year (fall 2027 or spring 2028,) the Arts Administrator, Parks Superintendent, Foundation Executive Director and artist will determine, in writing, when/if the artwork is to be decommissioned.

In the case of decommissioning, unresolvable safety concerns, or disrepair the artist will have 60 days to retrieve the artwork from the site. Remaining funds may be used to cover costs of decommissioning. At any point in between annual check-ins, the Parks Superintendent may request the artist retrieve the artwork due to unresolvable safety concerns or disrepair. The artist will have 60 days to retrieve the artwork from the date of request.

Impact

Given the location of the piece (between a parking lot and a sidewalk) we anticipate the impact on Elver Park users to be only positive by adding visual interest to a high traffic environment and enabling exposure to contemporary fine art. Maintenance staff should have no issues mowing as the cement pad will follow the outline of the sculpture closely, leaving more than a 6ft grass perimeter around the entire sculpture. Likewise, there should be sufficient space for snow removal. The piece may infringe upon some snow storage space. It would be desirable if the sculpture did not get totally buried in the winter as it may arguably add more to the space during snowy months than it does in the summer.

Signage

Signage will be designed by the artist to match the artwork.

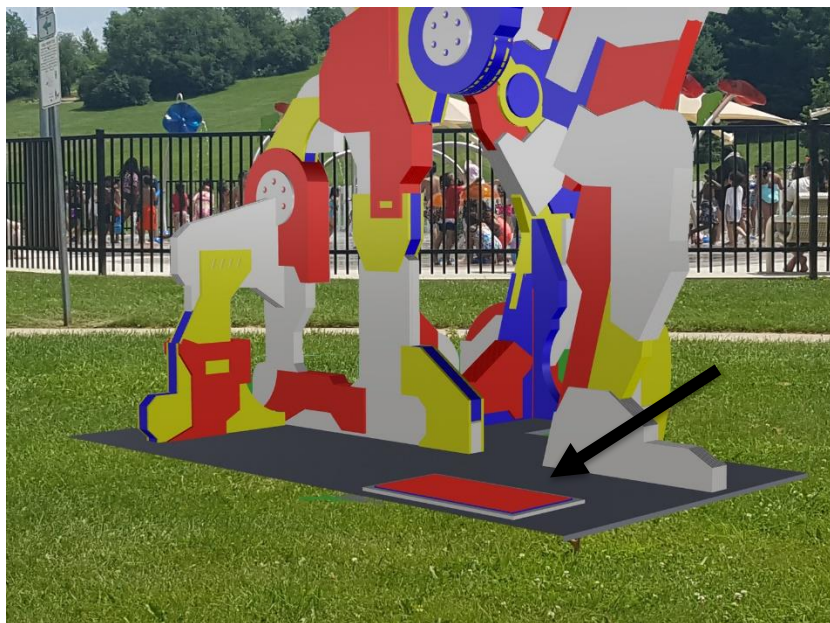

Signage Text:

Option A:
Momenta, 2018
By Jeffrey Repko

Commissioned by Makeshift Festival with funds from the Madison Arts Commission and Madison Parks Foundation
Please enjoy the sculpture but DO NOT CLIMB.

Option B:
Momenta, 2018
By Jeffrey Repko

Makeshift Festival is just one day but they brought this sculpture here to stay. Bright and fun, we know you'll want to play. Run through or around, but please ensure your feet do not leave the ground, so *Momenta* does leave this new home it has found.

Commissioned by Makeshift Festival with funds from the Madison Arts Commission and Madison Parks Foundation

Support

The artist and project manager used Makeshift Festival as an opportunity for feedback on the sculpture and they experience nothing but excitement and positive responses from the audience. Additionally, Makeshift organizers met with Alders McKinney and Phair on July 9, 2018 to present the project and solicit their input. Both alders were incredibly supportive of the artwork and location and Alder McKinney was especially excited. A letter of support has been set to the Parks Commission and been added to the legislative file.