



Certificate of Appropriateness  
1021 University Ave

January 11, 2021



# Proposed Work

- Replace damaged nonhistoric sign and retaining walls

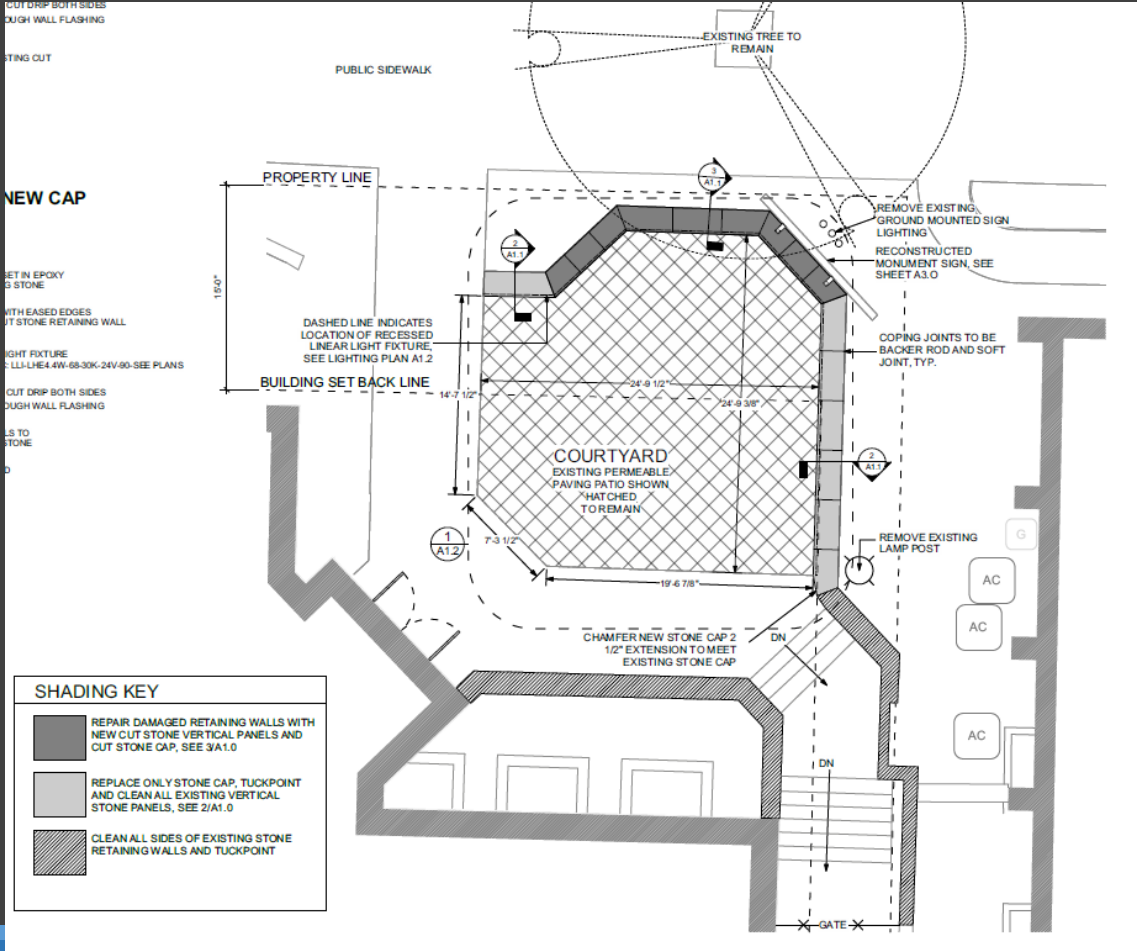



# Applicable Standards

## Secretary of the Interior's Standards for Rehabilitation

- 3. No create false sense of history
- 9. New construction differentiated from the old
- 10. New construction can be removed



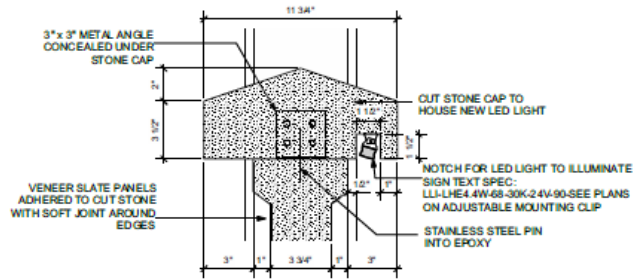

**4 LIGHT DETAIL**  
A3.0 Scale: 3" = 1'-0"

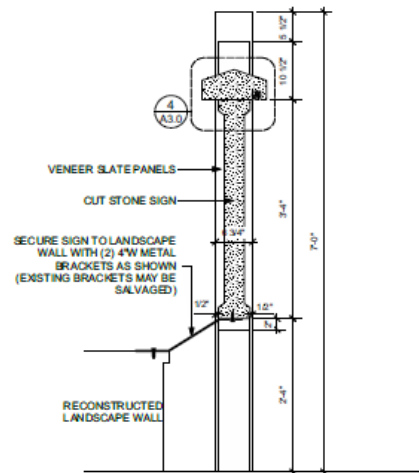

**3 SECTION**  
A3.0 Scale: 1" = 1'-0"

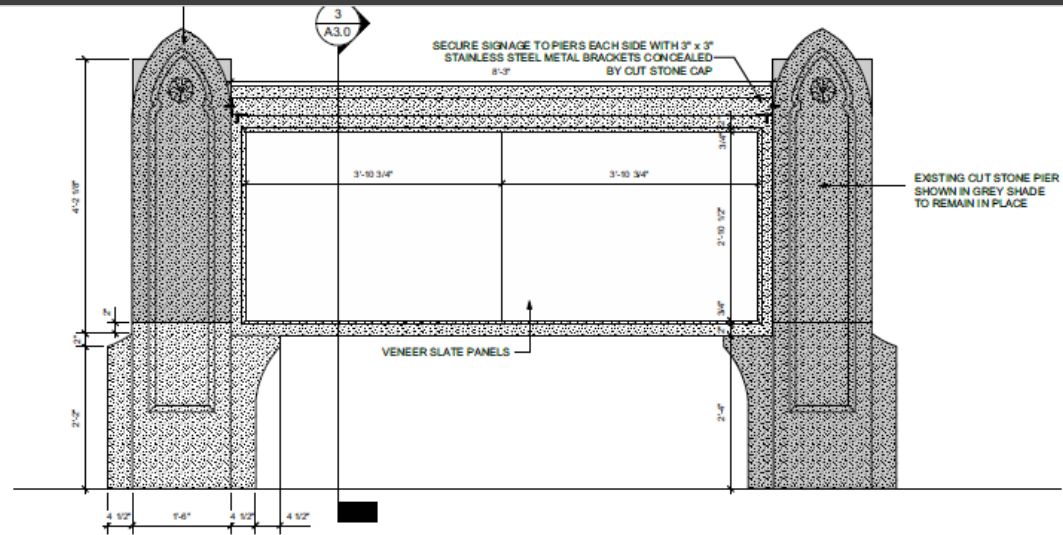

**1 COURTYARD FACING ELEVATION**  
A3.0 Scale: 1" = 1'-0"

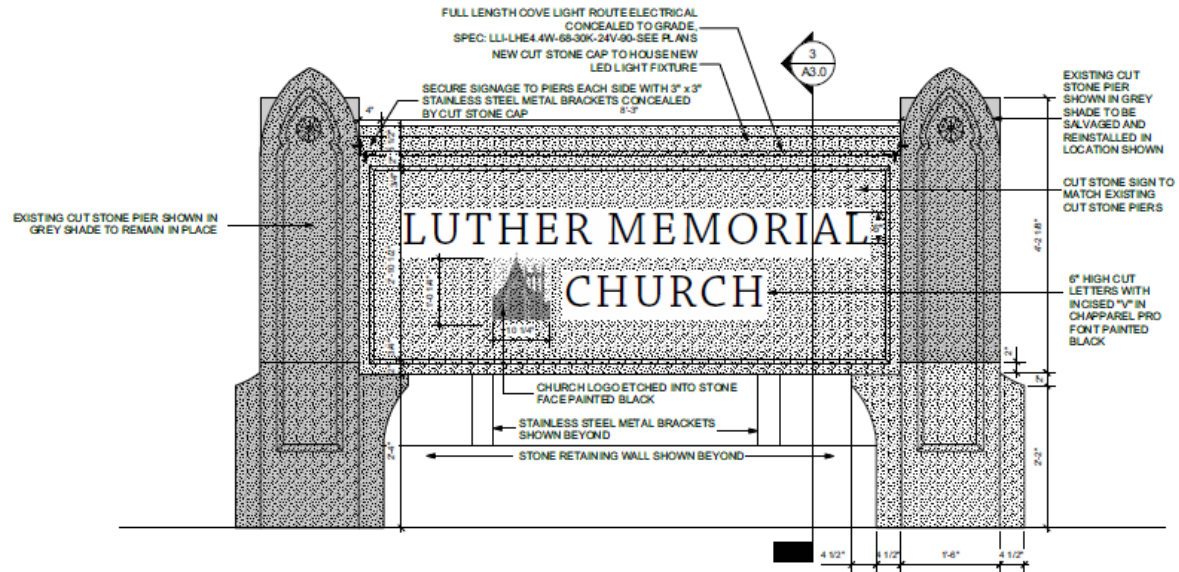

**2 STREET FACING ELEVATION**  
A3.0 Scale: 1" = 1'-0"



# Staff Recommendation

---

Staff believes the standards for granting a Certificate of Appropriateness are met and recommends that the Landmarks Commission approve the project as proposed.

