

City of Madison Landmarks Commission

APPLICATION

City of Madison Planning Division, 215 Martin Luther King Jr. Blvd., Suite LL.100, P.O. Box 2985, Madison, WI 53701-2985



1. LOCATION

Project Address: 1111 Williamson Street, Madison, WI 53703

Aldermanic District: _____

2. PROJECT

Project Title / Description: Stoop Alteration

This is an application for: *(check all that apply)*

- Alteration / Addition to a Designated Landmark
- Land Division/Combination of Designated Landmark site
- Alteration / Addition to a building adjacent to a Designated Landmark
- Alteration / Addition to a building in a Local Historic District *(specify):*
 - Mansion Hill Third Lake Ridge First Settlement
 - University Heights Marquette Bungalows
- Land Division/Combination in a Local Historic District *(specify):*
 - Mansion Hill Third Lake Ridge First Settlement
 - University Heights Marquette Bungalows
- New Construction in a Local Historic District *(specify):*
 - Mansion Hill Third Lake Ridge First Settlement
 - University Heights Marquette Bungalows
- Demolition
- Variance from the Historic Preservation Ordinance (Chapter 41)
- Referral from Common Council, Plan Commission, or other referral
- Landmark Nomination/Rescission or Historic District Nomination/Amendment
(Please contact the Historic Preservation Planner for specific submission requirements.)
- Other *(specify):* _____

PLANNING DIVISION USE ONLY	Legistar #

3. APPLICANT

Applicant's Name: Bradley Yocum Company: _____

Address: 1111 Williamson Street, Madison, WI 53703

Telephone: 570-852-0656 E-mail: Bradjy@icloud.com

Property Owner *(if not applicant)*: _____

Address: _____

Property Owner's Signature: Date: 07/11/16

NOTICE REGARDING LOBBYING ORDINANCE: If you are seeking approval of a development that has over 40,000 square feet of non-residential space, or a residential development of over 10 dwelling units, or if you are seeking assistance from the City with a value of \$10,000 (including grants, loans, TIF or similar assistance), then you likely are subject to Madison's lobbying ordinance (Sec. 2.40, MGO). You are required to register and report your lobbying. Please consult the City Clerk's Office for more information. Failure to comply with the lobbying ordinance may result in fines.

4. APPLICATION SUBMISSION REQUIREMENTS *(see checklist on reverse)*

All applications must be filed by 4:30 p.m. on the submission date with the Preservation Planner, the Department of Planning & Community & Economic Development, Planning Division, located in Suite LL-100, of the Madison Municipal Building, 215 Martin Luther King, Jr. Blvd. Applications submitted after the submittal date or incomplete applications will be postponed to the next scheduled filing time.

APPLICATION SUBMISSION REQUIREMENTS CHECKLIST:

In order to be considered complete, every application submission shall include at least the following information unless otherwise waived by the Preservation Planner.

- Landmarks Commission Application w/signature of the property owner (1 copy only).
- Twelve (12) collated paper copies 11" x 17" or smaller (via mail or drop-off) of submission materials (see below).
- Electronic files (via email) of submission materials (see below).
- Narrative Description/Letter of Intent addressed to the Landmarks Commission, describing the location of the property and the scope of the proposed project.
- Architectural drawings reduced to 11" x 17" or smaller pages which may include:
 - Dimensioned site plans showing siting of structures, grading, landscaping, pedestrian and vehicular access, lighting, signage, and other features;
 - Elevations of all sides showing exterior features and finishes, subsurface construction, floor and roof;
 - Floor Plan views of levels and roof;
 - For proposals of more than two (2) commercial or residential or combination thereof units, a minimum of two (2) accurate street-view normal perspectives shown from a viewpoint of no more than five (5) feet above existing grade.
- Any other information requested by the Preservation Planner to convey the aspects of the project which may include:
 - Photographs of existing conditions;
 - Photographs of existing context;
 - Manufacturer's product information showing dimensions and materials;
 - Other _____

CONTACT THE PRESERVATION PLANNER:

Please contact the Preservation Planner with any questions.

Amy Scanlon, Registered Architect
City of Madison Planning Division
215 Martin Luther King Jr. Blvd., Suite LL100 (physical address)
P.O. Box 2985 (mailing address)
Madison, WI 53701-2985
ascanlon@cityofmadison.com
608 266 6552

Bradley Yocum
1111 Williamson St.
Madison, WI 53703

July 11, 2016

City of Madison Landmarks Commission
City of Madison Planning Division
215 Martin Luther King Jr. Blvd., Suite LL.100
P.O. Box 2985
Madison, WI 53701

Dear Landmarks Commission,

I seek your approval replacing an unsafe stoop in disrepair at 1111 Williamson St with minor alterations listed below. The problem stoop has settled on one side making for an uneven step into the front door and the concrete has crumbled making the anchors that hold the budget railing defective.

Alterations:

- Constructed of yellow pine with rebar balusters instead of concrete with a budget metal railing.
- Approx. 2 feet wider and 1.5 feet longer to allow more room for entering with the storm door swinging out and also easier safer access to mailboxes situated on either side of the door.
- Railings all around and on both sides of the stairs as opposed to railing on one side only.

The railings include 3/8 rebar balusters spaced 3", custom ripped handrails and bottom rails with beveled edges and copper post caps. The flooring is 5/4 and lattice will cover the bottom. I intend on painting or staining all the lumber when it has fully dried and acclimated.

Thank you for your time and consideration in this matter.

Sincerely,
Bradley Yocum

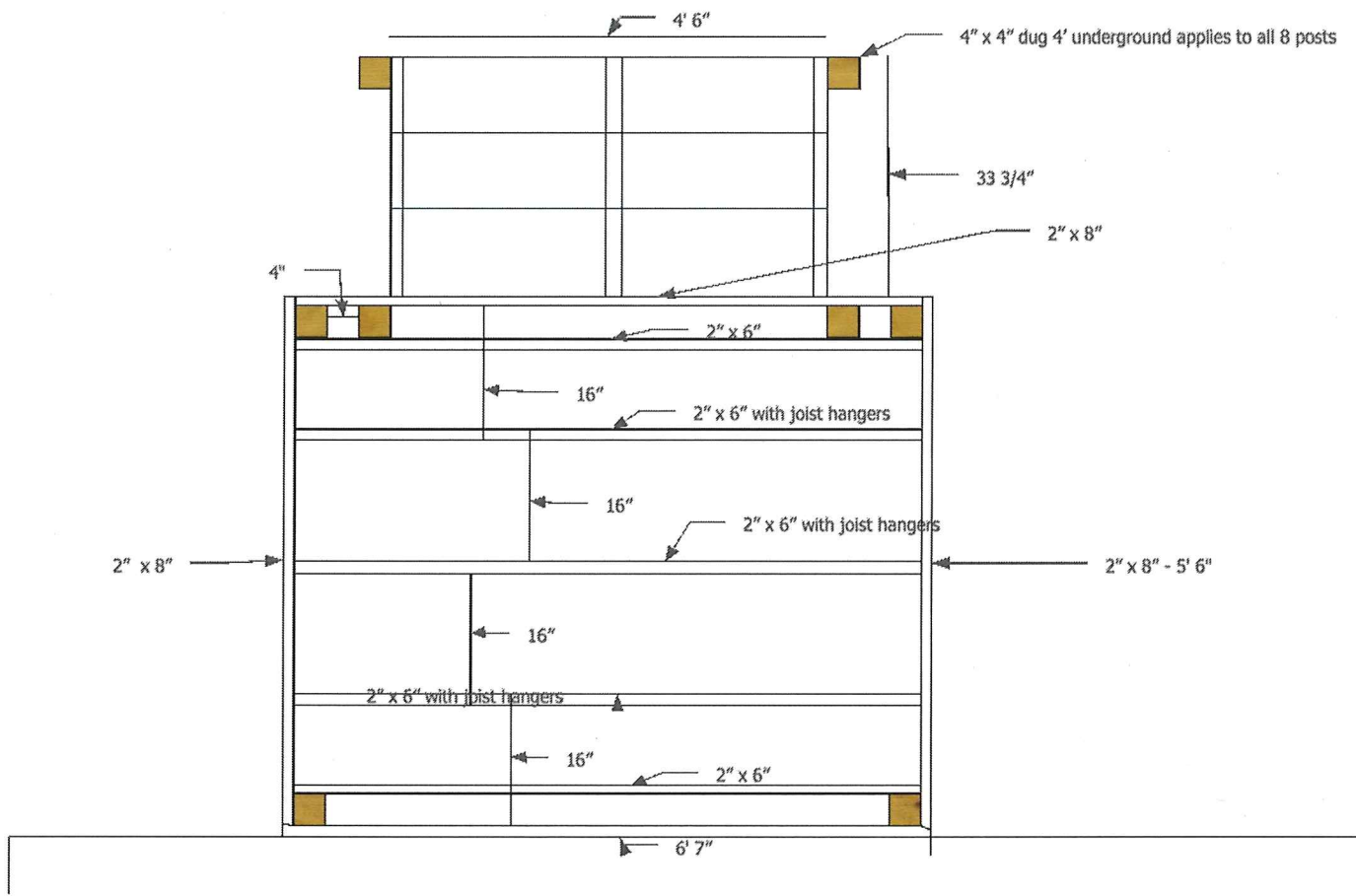

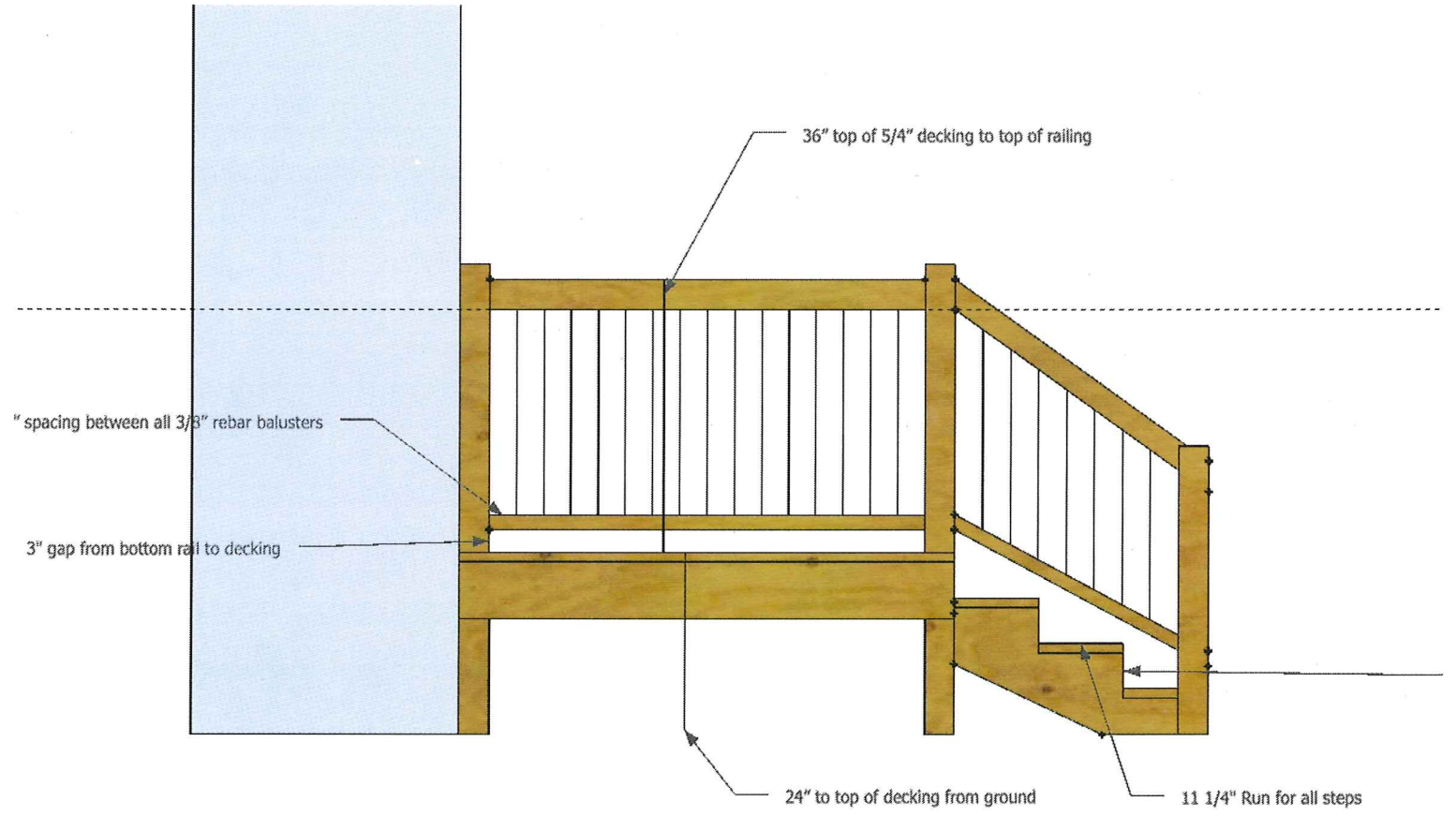



1111 Williamson Before



1111Williamson After