

# Madison Bus Rapid Transit

University Runningway Options

October 19, 2020

MADISON DEPARTMENT



OF TRANSPORTATION

# Bus Rapid Transit



# Vehicles Per Day

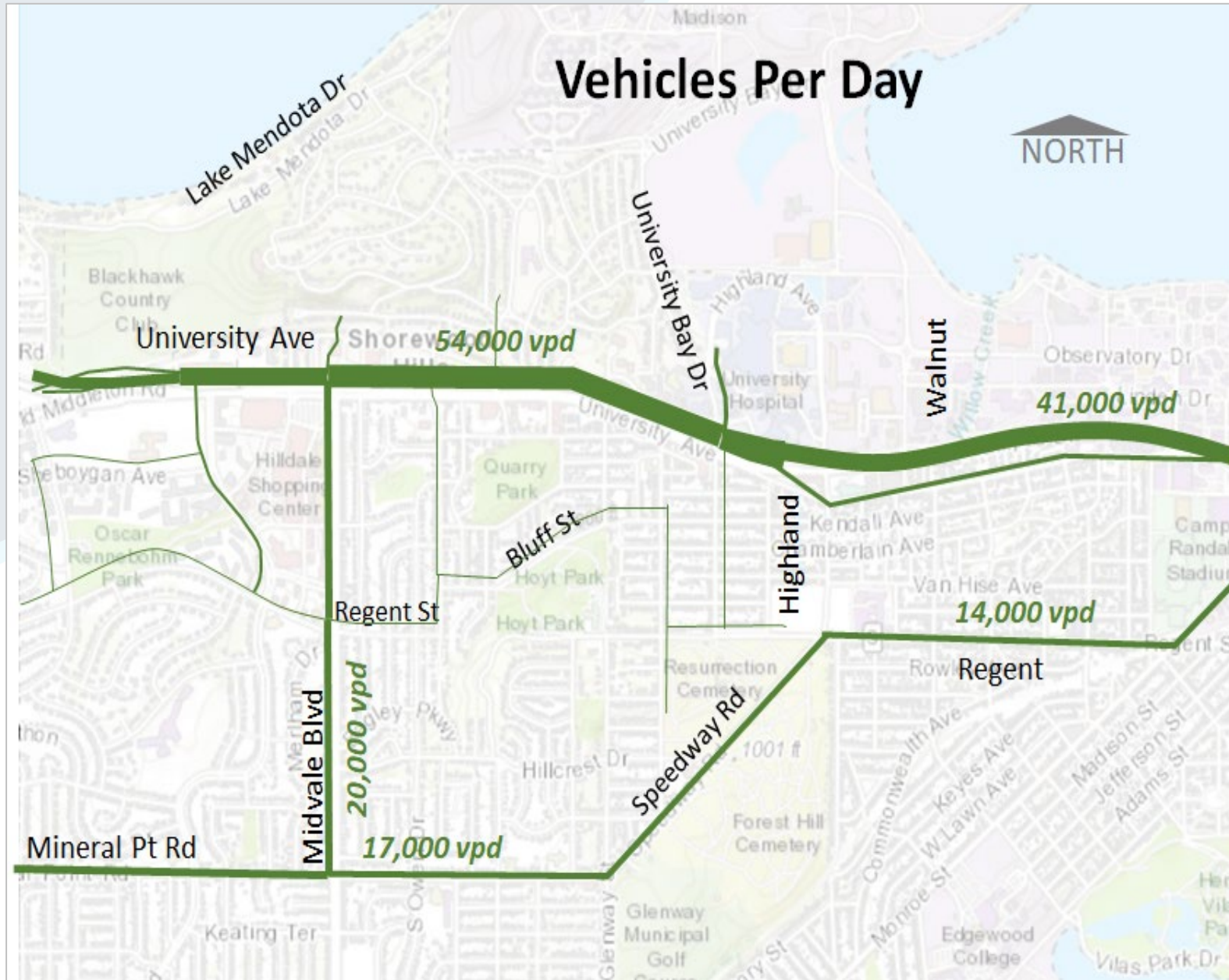

MADISON DEPARTMENT



OF TRANSPORTATION

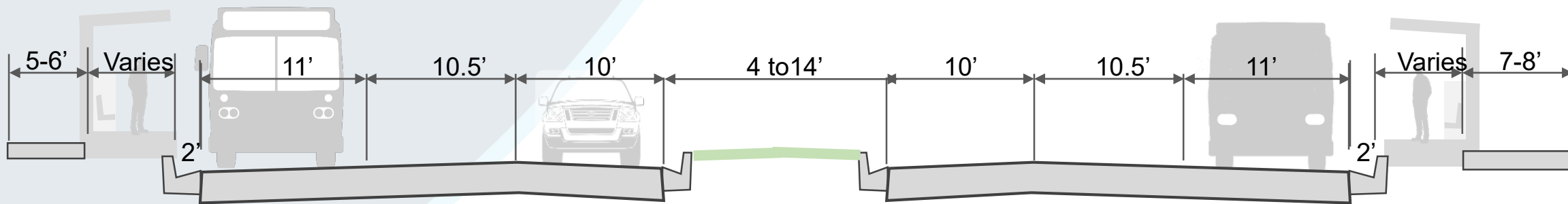

BRT in mixed traffic

**Alternative 1**  
(as approved)

BRT in mixed traffic

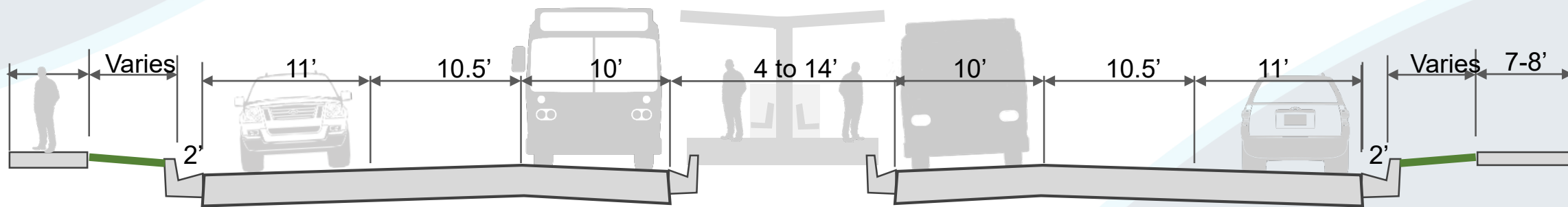

BRT  
dedicated  
lane

**Alternative 2**  
(Capacity Reduction)

BRT  
dedicated  
lane

MADISON DEPARTMENT



OF TRANSPORTATION

# Alternative 2 Restrictions

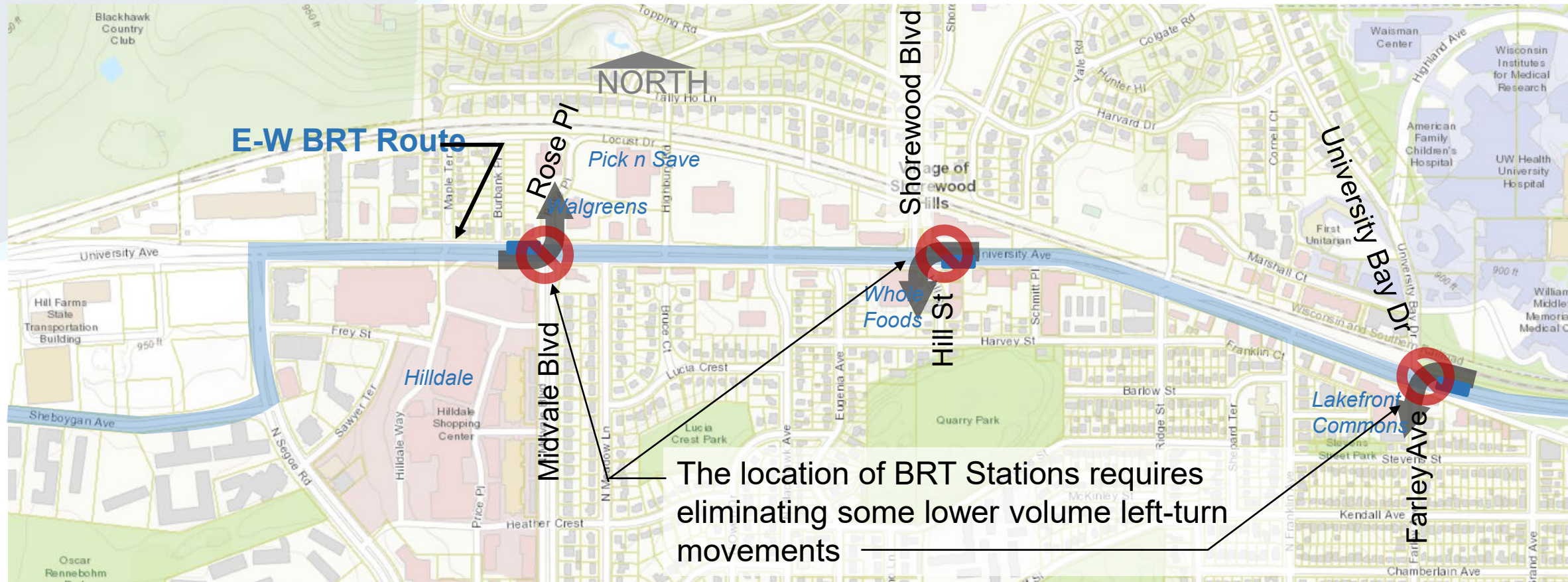

MADISON DEPARTMENT



OF TRANSPORTATION

# Jurisdiction

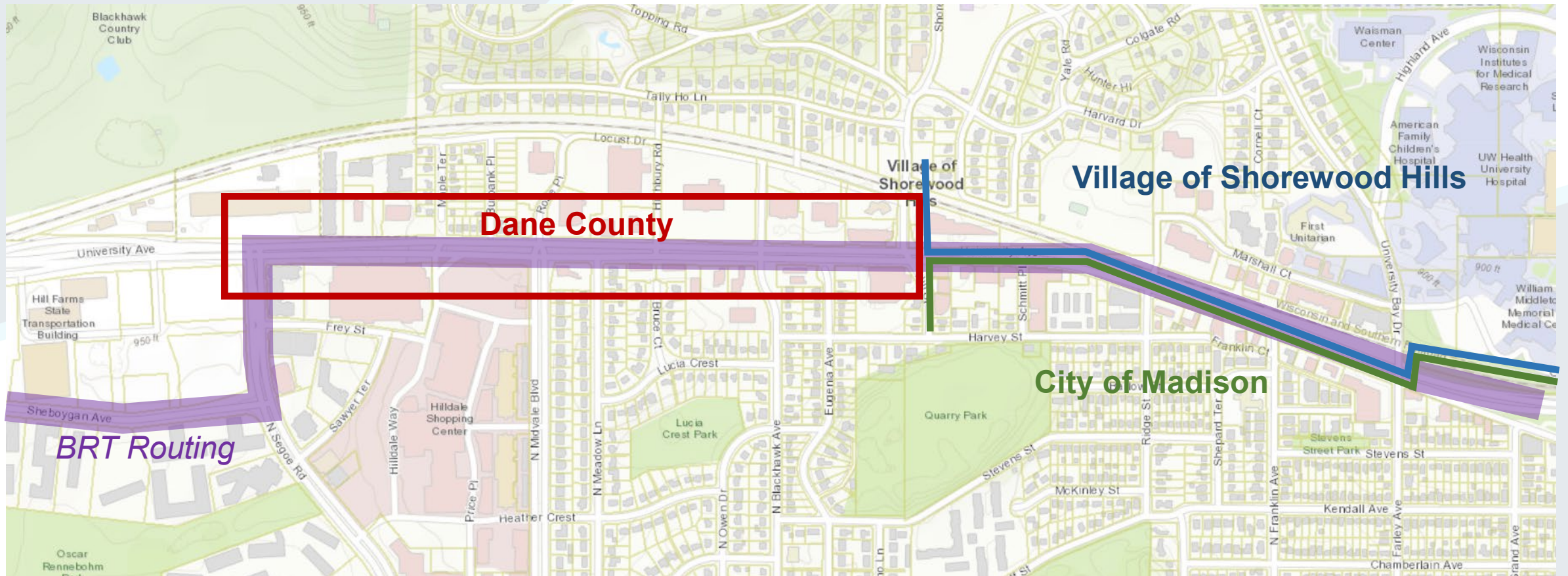

MADISON DEPARTMENT



OF TRANSPORTATION

# Redirection with Capacity Reduction

Travel Demand Model Traffic Changes with Scenario 4,  
One University Ave Travel Lane Removed in Each Direction and Dedicated to Transit

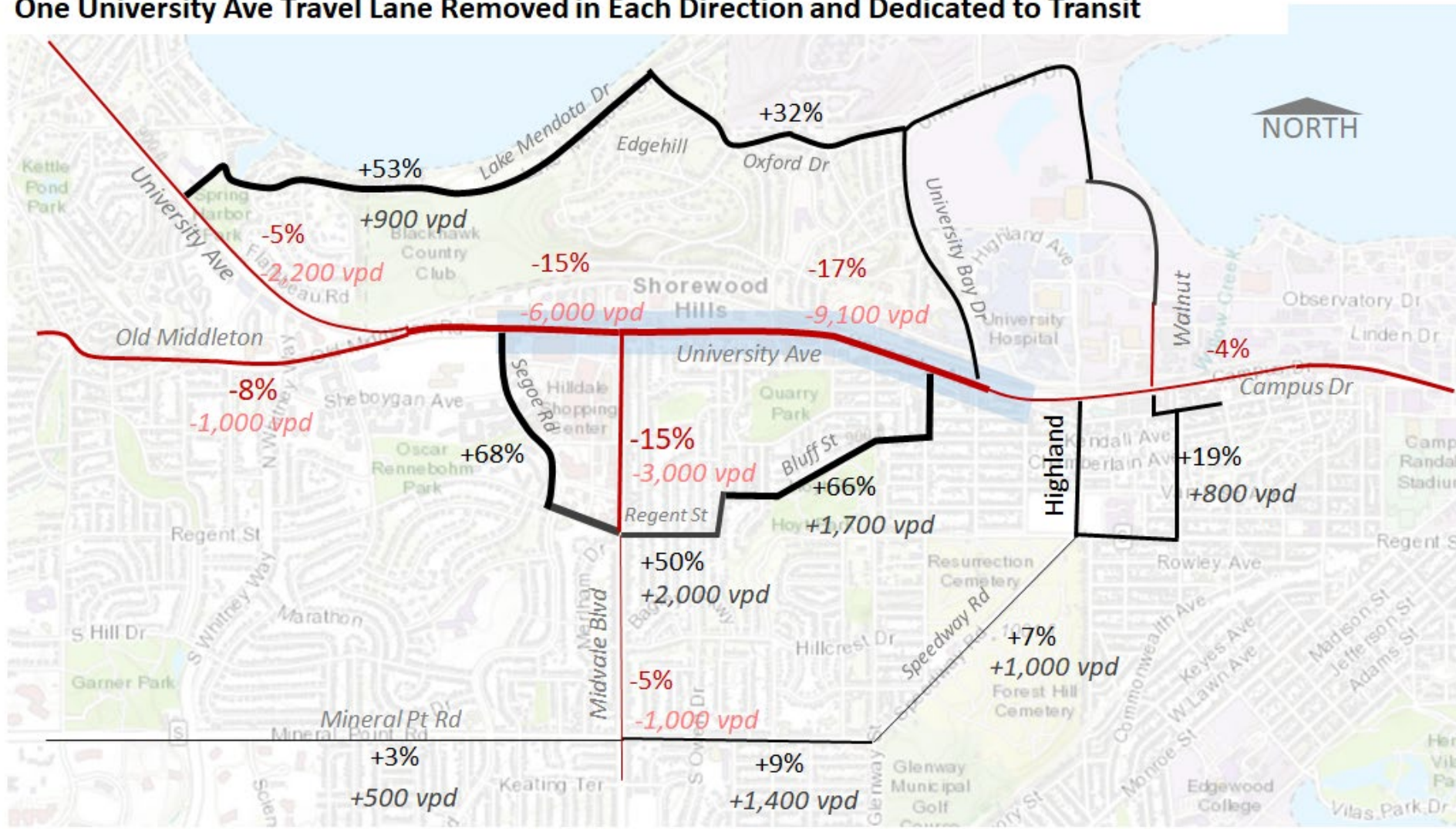

Alternative 2

Alternative 1

### Travel Time EB University AM

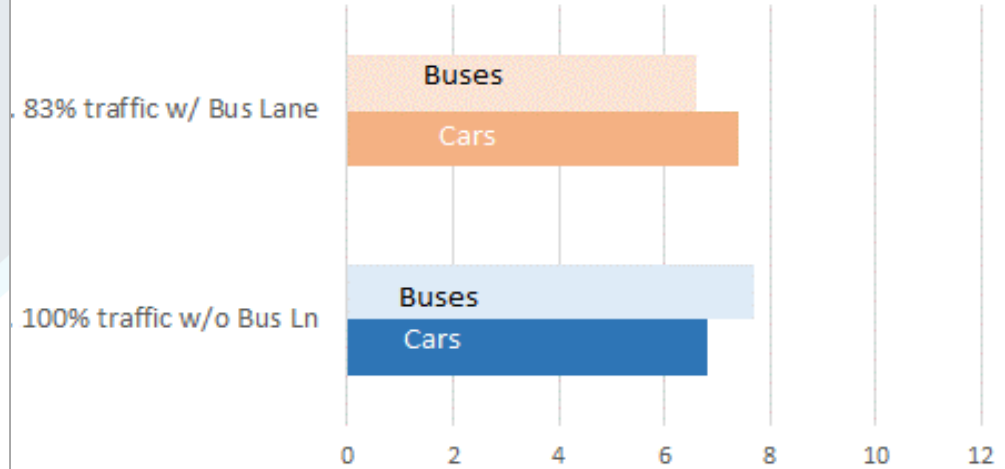

Alternative 2

Alternative 1

### Travel Time WB University PM

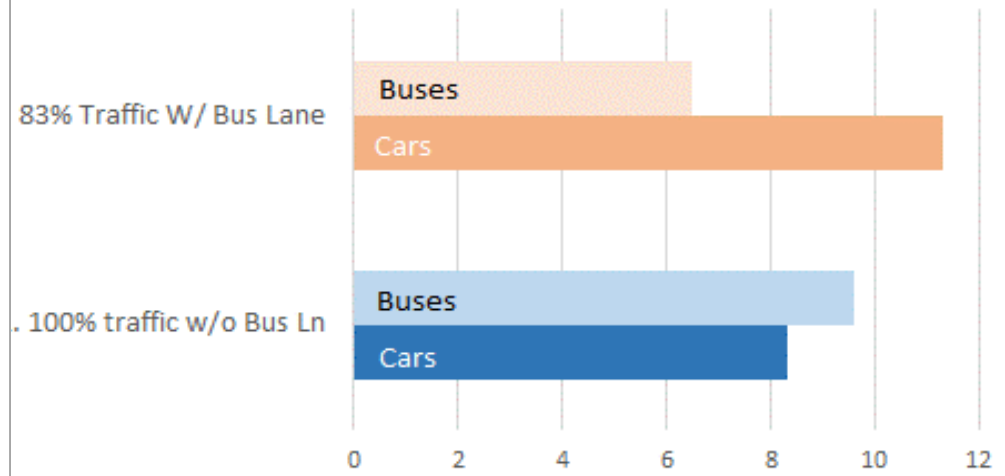



# Recommending Continuing with Current Proposal

- Initial meetings with stakeholders indicated strong concerns regarding traffic diversion.
- Suspected business concerns regarding elimination of left turns.
- All three jurisdictions would have to fully endorse lane reduction plan by early 2021 to not jeopardize federal funding. Includes revisions to environmental documentation.
- Despite some dissatisfaction, the current proposal went through public process with multiple stakeholders and is approved by Village Shorewood Hills and Madison.
- Side running does not preclude dedicated BRT lane in future.

MADISON DEPARTMENT



OF TRANSPORTATION