

WEST 1/4 SEC. 33-T8N-R10E
FOUND BRASS CAP
N: 497,078.92 E: 836,828.64

S89°46'03"W 2633.08'

MONUMENTED CENTER OF
SECTION 33-T8N-R10E FND.
BRASS CAP IN WATER BOX
N: 497,089.60 E: 839,461.70
(N: 497,089.47 E: 839,461.70)

RELOCATION ORDER APPROVED
BY THE PLAN COMMISSION:

RELOCATION ORDER APPROVED
BY THE BOARD OF PUBLIC WORKS:

RELOCATION ORDER APPROVED
BY THE COMMON COUNCIL:
RES- _____ FILE ID NO. _____

EXECUTIVE SECRETARY

DATE

EXECUTIVE SECRETARY

DATE

CITY CLERK

DATE

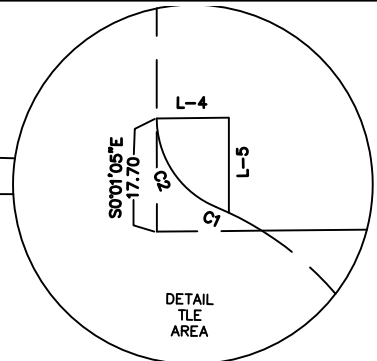
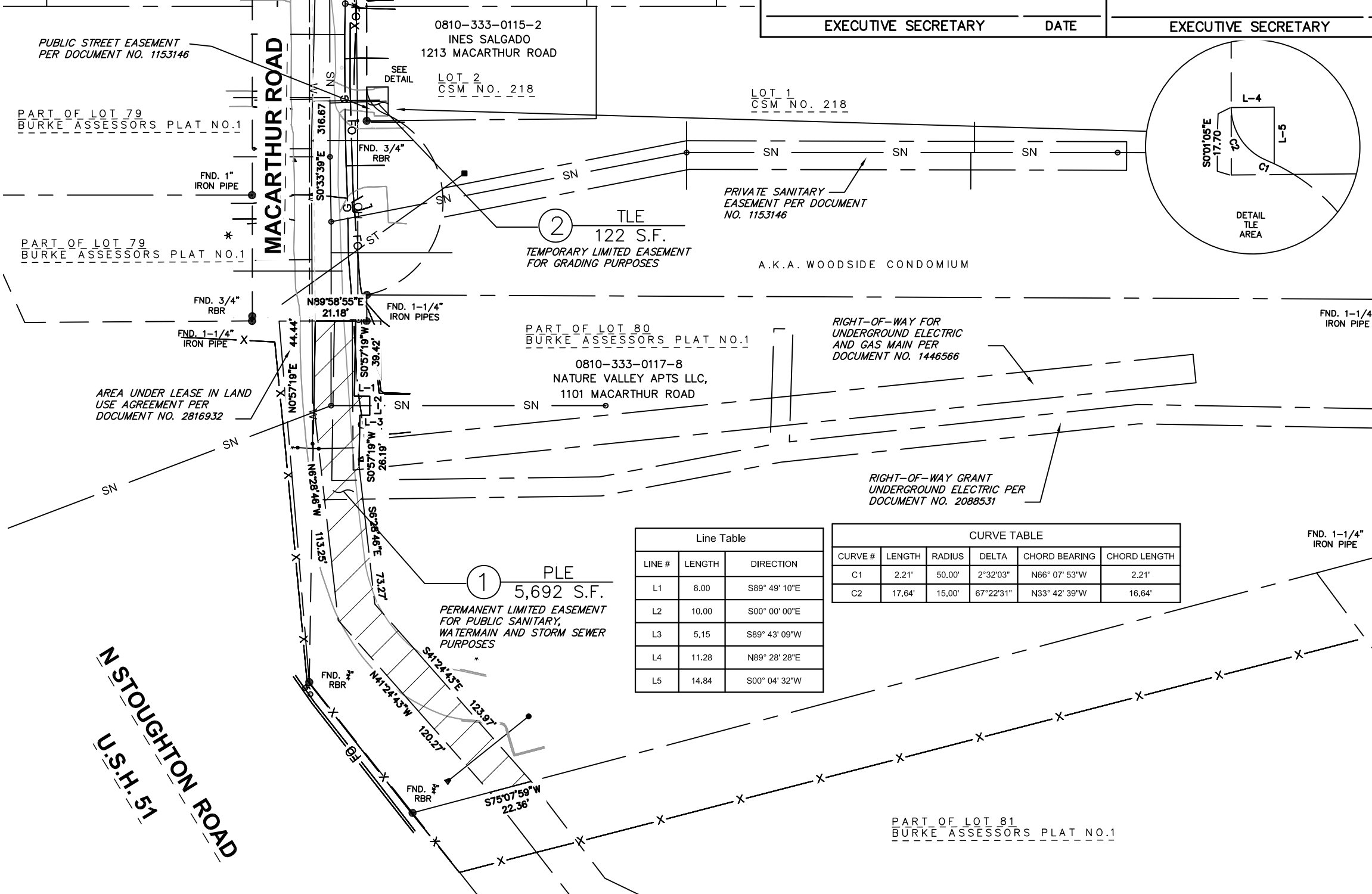

Surveyor's Certificate

State of Wisconsin)
County of Dane) SS

I, Julius W. Smith, Professional Land Surveyor in the State of Wisconsin, do hereby certify that I have surveyed and mapped the above platted property in accordance with the information furnished and in compliance with the requirements of Chapter AE-7, Wisconsin Administrative Code; and that the above map is an accurately scaled and dimensioned representation of such survey showing the location of the boundaries, visible buildings, if any, to the best of my knowledge and belief.

City of Madison, Wisconsin
By: Julius W Smith

Julius W. Smith S-3091 Date

② TLE
122 S.F.
TEMPORARY LIMITED EASEMENT
FOR GRADING PURPOSES

① PLE
5,692 S.F.
PERMANENT LIMITED EASEMENT
FOR PUBLIC SANITARY,
WATERMAIN AND STORM SEWER
PURPOSES

LINE #	LENGTH	DIRECTION
L1	8.00	S89° 49' 10"E
L2	10.00	S00° 00' 00"E
L3	5.15	S89° 43' 09"W
L4	11.28	N89° 28' 28"E
L5	14.84	S00° 04' 32"W

CURVE #	LENGTH	RADIUS	DELTA	CHORD BEARING	CHORD LENGTH
C1	2.21'	50.00'	2°32'03"	N66° 07' 53"W	2.21'
C2	17.64'	15.00'	67°22'31"	N33° 42' 39"W	16.64'

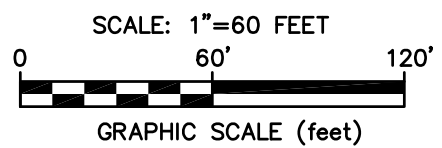

NORTH BASED ON WISCONSIN COUNTY
COORDINATE SYSTEM, WCCS DANE
ZONE NAD 83(2011).
NORTH LINE OF THE SOUTHWEST
QUARTER MEASURED TO BEAR
S89°46'03"W

SCHEDULE OF INTERESTS REQUIRED

PARCEL #	OWNER NAME	PLE AREA REQUIRED	RELEASE OF RIGHTS	TLE AREA REQUIRED	DOCUMENT NUMBER
①	NATURE VALLEY APTS LLC,	5,692 SQ FT 0.131 ACRES			
②	INES SALGADO			122 SQ FT 0.003 ACRES	

CITY OF MADISON
RELOCATION ORDER

"PLAT OF LAND INTERESTS REQUIRED FOR THE CONSTRUCTION, MAINTENANCE AND USE OF PUBLIC EASEMENTS"; LOCATED IN PARTS OF OUTLOT 80 OF BURKE ASSESSORS PLAT NO 1, AND LOT 2 OF CSM 218, BEING A PART OF THE NE 1/4 OF THE SW 1/4 OF SECTION 33, T1N R10E, CITY OF MADISON, DANE CO, WISCONSIN.

CITY ENGINEERING DIVISION
PROJECT NO. Munis 15120
REAL ESTATE PROJECT NO. 13276
COUNTY CLERK FILE NO. _____

MAY 01, 2026
REV. X/XX/2026
SHEET 1 OF 1

M:\DESIGN\Projects\11865\CAD\Survey\Relocation Order\11865SY-Relocation.dwg