

SUBCHAPTER 28L: BUILDING FORM STANDARDS

28.171 GENERAL PROVISIONS.

(1) Statement of Purpose.

A variety of building forms are defined here in order to identify and establish basic design parameters for those buildings that may be appropriate in one or more zoning districts. The purposes of design standards are:

- (a) To ensure compatibility between different land uses and building forms;
- (b) To encourage building forms that respect their context;
- (c) To encourage pedestrian movement by encouraging building forms that present an active face to the street.

(2) Applicability.

The design standards in this Subchapter shall apply to new buildings or building additions that exceed the gross floor area occupied by a given use by more than fifty percent (50%), with the exceptions listed below. Building additions shall comply with the design standards to the extent feasible, given the placement of the existing building. In all cases, design standards shall apply only to the portion of the building or site that is undergoing alteration

Some design standards are closely linked to a specific building form (for example, a parking building). Other design standards vary by district, and are listed in those district subchapters.

Building types that are not listed in this Subchapter may be allowed if they meet the intent and other design standards of the district where they would be located.

(3) Exceptions and Waivers.

The design standards in this Section shall not apply within those zoning districts where buildings are specifically exempted from these design standards. Where there is a conflict between the design standards in this Section and the standards within a particular district, the district standards shall take precedence.

A waiver or modification of any standard may be requested as part of site plan review if the applicant can demonstrate that there are circumstances unique to the property that make compliance impractical or unreasonable. Waivers may be granted by the Zoning Administrator following review by the Urban Design Commission. The applicant may appeal the Zoning Administrator's decision to the Zoning Board of Appeals.

28.172 RESIDENTIAL BUILDING FORMS.

(1) Use of Dormers.

Dormers may be added to the roof of a two-story building, provided that the dormer width does not exceed fifty percent (50%) of the lineal width of the floor immediately below the roof.

(2) Single-Family Detached Building.

- (a) Building Type. A single-family dwelling with yards on all sides, oriented to the street, with an attached or detached garage.
- (b) Access and Entry. Each dwelling shall have direct access from a porch, stoop or courtyard to the street. Parking, loading and trash disposal may be accessed from an alley or driveway.
- (c) Parking. Surface parking may be located in the side or rear yard setbacks or within the building envelope, as specified in Section 28.141.
- (d) Attached Garages. See Section 28.031(3), Attached Garage Setback.
- (e) Frontage. Each building must include a stoop, porch or courtyard oriented towards the primary abutting street.
- (f) Building Width. Buildings facing a public street shall not exceed a width of fifty (50) feet along a single plane on the axis facing the street. Additional building wings facing the street shall be set back at least five (5) feet behind the front plane of the building.

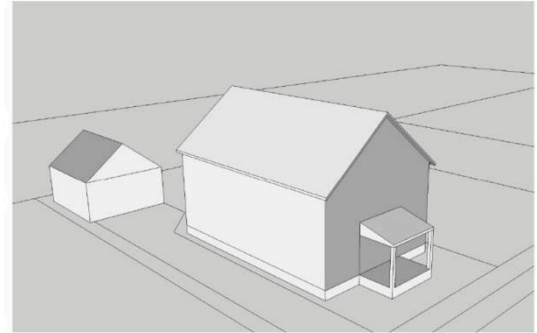

Typical Single Family Detached Building

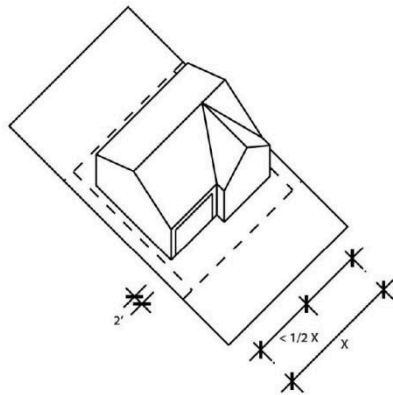

Attached Garage Setback

(3) Two-Flat and Three-Flat Buildings.

(a) Building Types.

1. **Two-Flat.** A building containing two dwelling units that are vertically stacked one above the other, with a separate entrance to each unit and with yards on all sides.
2. **Three-Flat:** A building containing three dwelling units that are vertically stacked one above the other, with a separate entrance to each unit and with yards on all sides.

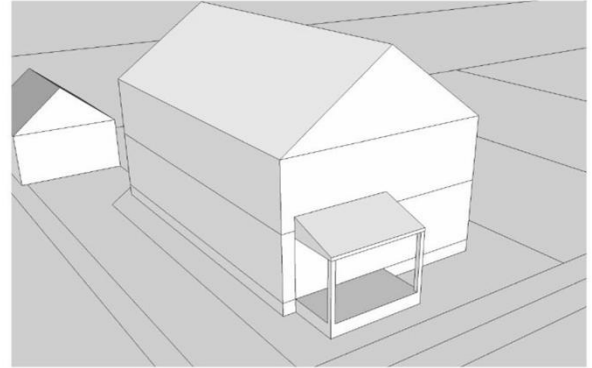

Typical Two-Flat Building

- (b) Access and Entry. At least one of the dwellings shall have direct access from a common porch or stoop facing the front lot line and street. Parking, loading and trash disposal may be accessed from an alley or driveway.
- (c) Parking. Surface parking may be located in the side or rear yard setbacks or within the building envelope (see Section 28.141).
- (d) Attached Garages. See Section 28.031(3), Attached Garage Setback.
- (e) Frontage. Each building must include a stoop, porch or terrace serving at least one of the dwelling units, oriented toward the primary street.
- (f) Building Width. Buildings facing a public street shall not exceed a width of forty (40) feet along a single plane on the axis facing the street. Additional building wings facing the street shall be set back at least five (5) feet behind the front plane of the building.

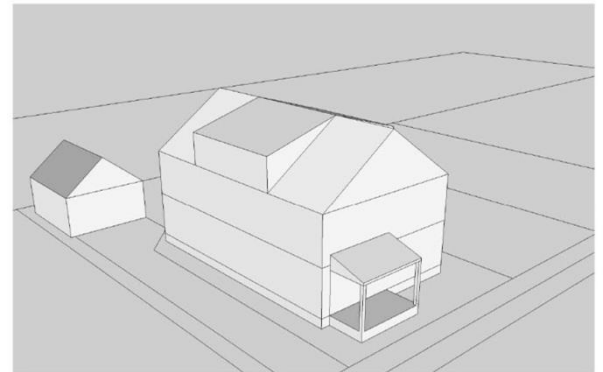

Typical Three-Flat Building

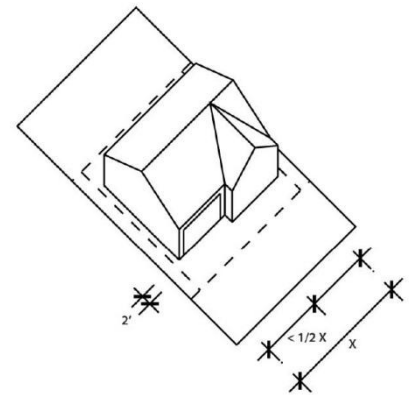

Attached Garage Setback

(4) Two-Family Building, Twin.

(a) Building Type. A building containing two attached dwelling units that share a common side wall and that are usually on separate lots, with the common wall at the lot line. If the dwellings are on separate lots, the common wall must be located on the side lot line. The dwellings can also be treated as condominiums, with a third ownership area consisting of the remainder of the lots.

(b) Access and Entry. Each dwelling shall have direct access from a common or separate porch or stoop; at least one entrance shall face the front lot line.

Parking, loading and trash disposal may be accessed from an alley or driveway. Both units may, (and are encouraged to) share a common driveway.

(c) Parking. Surface parking may be located in the side or rear yard setbacks or within the building envelope. (see Section 28.141).

(d) Attached Garages. See Section 28.031(1), Attached Garage Setback.

(e) Frontage. Each building must include a stoop, porch or terrace serving at least one of the dwelling units, oriented toward the primary street.

(f) Building Width. Buildings facing a public street may not be wider than fifty (50) feet along a single plane on the axis facing the street. Additional building wings facing the street shall be set back at least five (5) feet behind the front plane of the building.

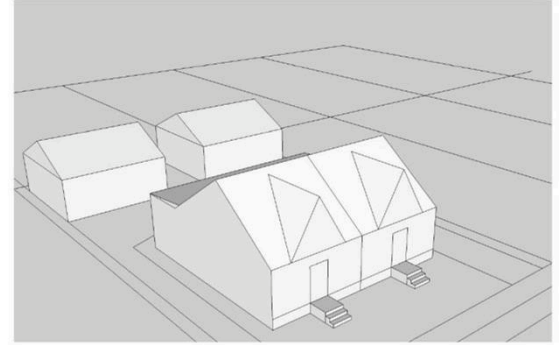

Typical Two-Family Twin Building

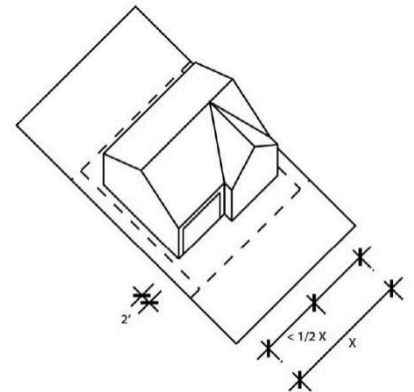

Attached Garage Setback

(5) Single-Family Attached Building, Townhouse, Rowhouse.

(a) Building Type. A dwelling unit within a linear group of horizontally attached dwellings, each having a private entrance and totally exposed front and rear walls to be used for access, light and ventilation. Buildings may be oriented to the street or to a central green or courtyard.

(b) Access and Entry. The principal entry to

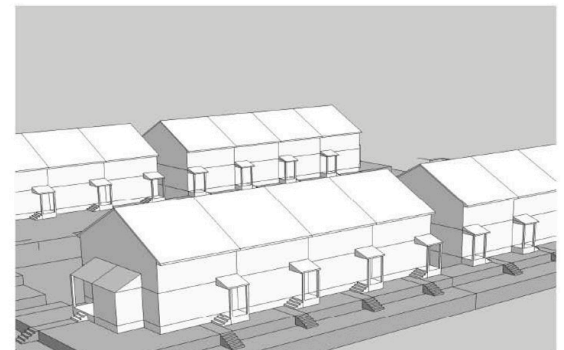

Typical Single Family Attached Buildings

each dwelling shall have direct access to the street or to a courtyard.

Parking, loading and trash disposal may be accessed from an alley or common side yard driveway serving one or more buildings.

- (c) Parking. Parking shall be located behind each building or in a common parking court in the interior of a block. Parking may be in a variety of configurations: surface, “tuck-under,” underground, or within an attached or detached garage to the rear of the principal building. Surface or structured parking may be located within the side yard provided that it occupies no more than twenty-five (25%) of the frontage along the primary abutting street.
- (d) Frontage. Each dwelling must include a stoop or porch or a common green or courtyard oriented toward the primary street.
- (e) Massing and Articulation. Buildings facing a public street shall be comprised of individual units, articulated vertically to create visual interest and continuity. Divisions or breaks in materials, entry placement, window bays or other architectural details shall be used to delineate individual units.

Massing, proportions and articulation of single-family attached buildings should respond to existing residential buildings in their vicinity. Maximum building length parallel to the primary abutting street shall not exceed one hundred sixty (160) feet without a significant articulation of the facade.

- (f) Landscaping. Front yards shall be landscaped to provide visual screening and privacy. Landscaping may consist of trees, shrubs, and/or groundcovers, in combination with decorative fences or walls.



(6) Small Apartment Building.

(a) Building Type. A multi-story multi-family building with a central entrance oriented to the primary abutting street, containing four to eight units. Buildings of this type are sometimes designed to resemble a large single-family building with a pitched roof.

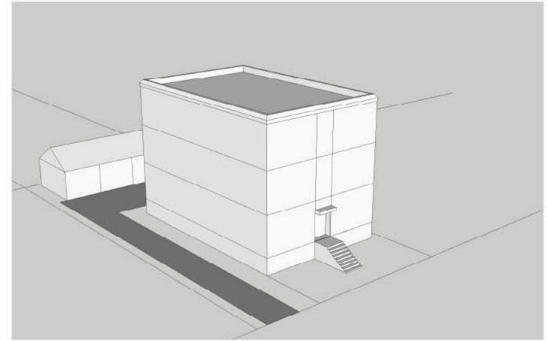

Typical Small Apartment Building

(b) Access and Entry. The principal entry to the building shall be oriented to the primary abutting street.

Parking, loading and trash disposal may be accessed from an alley or common sideyard driveway serving one or more buildings.

(c) Parking. Parking shall be located behind each building, below the building, or in a common parking court in the interior of a block. Surface or structured parking may be located within the side yard provided that it occupies no more than twenty-five percent (25%) of the frontage along the primary abutting street.



(d) Frontage. Each building must include a stoop or porch or a common green or courtyard, oriented toward the primary street.



(e) Massing and Articulation. Massing, proportions and articulation of small apartment buildings should respond to existing residential buildings in their vicinity, including features of those buildings such as roof pitch, proportions of windows and doors, and placement on the lot. Building facades shall be articulated vertically and horizontally for visual interest.

(f) Landscaping. Front yards shall be landscaped to provide visual screening and privacy. Landscaping may consist of trees, shrubs, and/or groundcovers, in combination with decorative fences or walls.

(7) Large Apartment Building, Stacked Flats.

- (a) Building Type. A multi-story building with combined entrances, stairways and elevators, comprised of single- or two-level occupant spaces stacked on top of each other, typically accessed from a central corridor.
- (b) Access and Entry. The principal entry to the building shall be oriented to the primary abutting street. Parking, loading and trash disposal may be accessed from an alley or common drive serving one or more buildings.
- (c) Parking. Parking shall be located behind each building, under the building, or in a common parking court in the interior of a block. Parking may be located within the side yard provided that it occupies no more than twenty-five percent (25%) of the frontage along the primary abutting street. Structured parking at ground floor level shall not be visible from the front façade of the building.
- (d) Frontage. Each building must include a stoop or porch oriented to the street.
- (e) Massing and Articulation. Massing, proportions and articulation of single-family attached buildings should respond to existing residential buildings in their vicinity. Maximum building length parallel to the primary abutting street shall not exceed one hundred sixty (160) feet without a significant articulation of the facade. Facades facing a public street shall be vertically articulated at a minimum interval of forty (40) feet.
- (f) Landscaping. Front yards shall be landscaped to provide visual screening and privacy. Landscaping may consist of trees, shrubs, and/or groundcovers, in combination with decorative fences or walls.

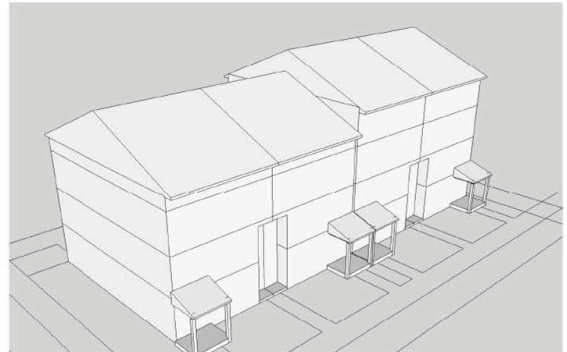

Typical Large Apartment Building



(8) Courtyard Apartment Building.

- (a) Building Type. A multi-story multi-family building designed around an open courtyard abutting a primary street, surrounded by building walls on three sides.
- (b) Access and Entry. The principal entry to the building shall be oriented to the primary abutting street or courtyard. The courtyard shall be oriented to a street and shall be largely visible from the street, but may be separated from the street by a decorative fence.

Parking, loading and trash disposal may be accessed from an alley, through the courtyard, or through a common drive serving one or more buildings.

- (c) Parking. Parking shall be located behind each building or wholly or partially underground. Structured parking visible at ground floor level shall not be visible from the front façade of the building. Surface parking may be located to the side yard of a courtyard building provided that it occupies no more than twenty-five percent (25%) of the frontage along the primary abutting street.
- (d) Massing and Articulation. Buildings may be divided into individual attached units at ground level or served by shared entrances. Maximum building length parallel to the primary abutting street shall not exceed one hundred sixty (160) feet without a significant articulation of the facade. Facades facing a public street shall be vertically articulated at a minimum interval of forty (40) feet.
- (e) Landscaping and Open Space. Courtyards shall be a minimum of thirty-five (35) feet in width or depth, and shall be maintained as common open space for residents. Courtyards shall be fully landscaped and may also include play structures and other amenities.

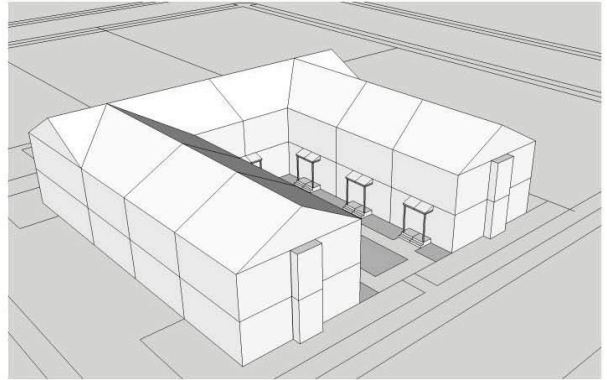

Typical Courtyard Apartment Building



(9) Carriage House Building.

- (a) Building Type. A building containing a detached garage and an accessory dwelling unit of modest size located above the garage. It is located on an alley or on the rear one-third of a lot that includes a principal building.
- (b) Access and Entry. The principal entry to the unit shall be accessed from the side or rear yard or alley. The entry shall be connected to the abutting street by a paved walkway.
- (c) Parking. Parking shall be located below or beside the unit and accessed from an alley or side yard driveway.
- (d) Building Design. Carriage houses shall employ materials, roof pitch, orientation, door and window placement and proportions, and other details compatible with those of the principal building.

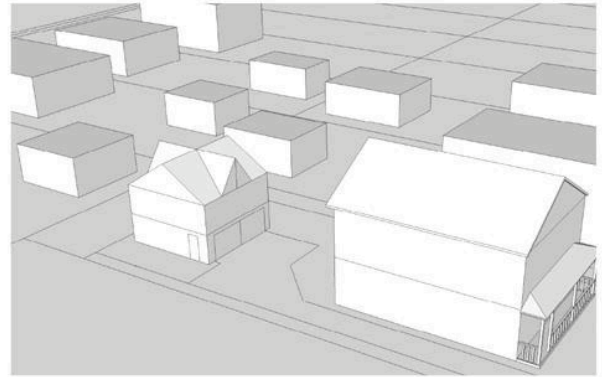

Typical Carriage House Building



28.173 MIXED USE AND NON-RESIDENTIAL BUILDING FORMS.

(1) Commercial Block Building.

- (a) Building Type. A multi-story building that is designed to support a mix of commercial or office uses on the ground floor with office, studio, lodging and/or residential units above. Buildings are typically designed with storefronts or arcades at ground floor.
- (b) Access and Entry. Principal entry to each ground floor unit shall be a direct entrance from the primary abutting street. Parking, loading and trash disposal may be accessed from an alley or through a sideyard or rearyard drive serving one or more buildings.
- (c) Parking. Parking shall be not be located between the building's front façade and the street. Parking may be located behind the rear plane of the principal building on the lot, or within a side yard, provided that no more than seventy (70) feet of lot

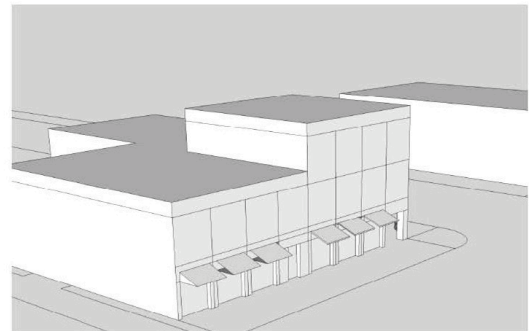

Typical Commercial Block Building

frontage along the primary abutting street is occupied by parking or driveways. Parking may also be wholly or partially underground, or in a common parking area in the interior of a block.

- (d) **Frontage.** Buildings shall be designed with storefronts, stoops or patios along at least forty percent (40%) of the front ground floor façade along the primary abutting street.
- (e) **Massing and Articulation.** Maximum building length parallel to the primary abutting street shall not exceed one hundred sixty (160) feet without a significant articulation of the facade. Facades facing a public street shall be vertically articulated at a minimum interval of forty (40) feet. Entrances shall be provided at least every forty (40) feet along the primary abutting street.



(2) **Liner Building.**

- (a) **Building Type.** A specialized building, parallel to the street, which is designed to conceal an area such as a parking lot or loading dock. While liner buildings may include commercial or residential uses, their limited depth (from front to back) makes them more disposed to residential use. Liner buildings may have a small common front yard, but do not include individual private outdoor spaces.
- (b) **Access and Entry.** The principal entry to each ground floor unit shall be a direct entrance from the primary abutting street.
- (c) **Massing and Articulation.** Maximum building length parallel to the primary abutting street shall not exceed three hundred (300) feet without a visual break such as a courtyard or recess. Minimum building depth is sixteen (16) feet. Facades facing a public street shall be vertically articulated at a minimum interval of forty (40) feet. Entrances shall be provided at least every forty (40) feet along the primary abutting street.

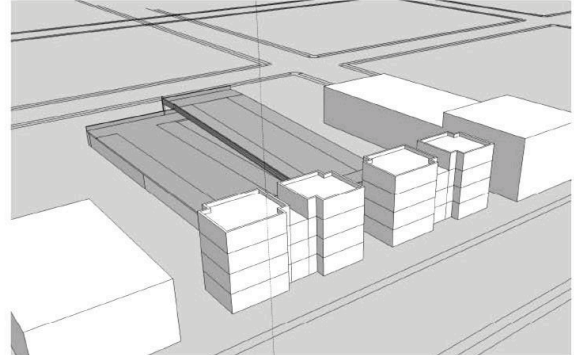

Typical Liner Building



(3) Parking Building.

- (a) Building Type. A multi-story building specifically designed for parking of automobiles on a temporary basis, which may also include ground-floor storefronts and upper-level office space. Often paired with a liner building along the street frontage.
- (b) Access and Entry. Principal entry to each ground floor business or unit shall be a direct entrance from the primary abutting street. Vehicular entrance drives shall be located and designed to minimize interference with pedestrian movement. Vehicular entrances on secondary streets are encouraged.
- (c) Building Design. The ground floor of any parking structure abutting a public street or walkway shall be designed and architecturally detailed in a manner consistent with new commercial or mixed-use buildings.

Upper floors shall be designed so that sloped floors typical of parking structures do not dominate the appearance of the façade.

Windows or openings shall be provided that echo those of surrounding buildings.

- (d) Massing and Articulation. Maximum building length parallel to the primary abutting street shall not exceed (300) feet without a visual break such as a courtyard or recess. Facades facing a public street shall be vertically articulated at a minimum interval of forty (40) feet. Entrances shall be provided at least every forty (40) feet along the primary abutting street.

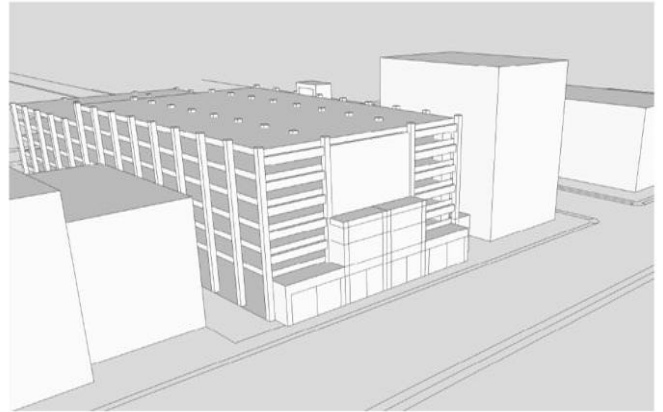

Typical Parking Building



(4) Live-Work Building.

- (a) Building Type. Similar to townhouses in scale and detailing, but with a ground floor designed for small commercial, office and service establishments, often with storefront detailing. Buildings are typically placed close to the sidewalk, although a forecourt or patio design may be used to allow for outdoor seating space.
- (b) Access and Entry. Principal entry to each ground floor unit shall be a direct entrance from the primary abutting street.
- (c) Parking. Parking shall be located behind each building or wholly or partially underground. Parking may be located within the side yard provided that it occupies no more than 25% of the lot frontage along the primary abutting street.
- (d) Massing and Articulation. Massing, proportions and articulation of live-work buildings should respond to existing residential buildings in their vicinity. Maximum building length along the primary abutting public street shall not exceed one hundred sixty (160) feet without a significant articulation of the facade. Facades facing a public street shall be vertically articulated at a minimum interval of forty (40) feet.

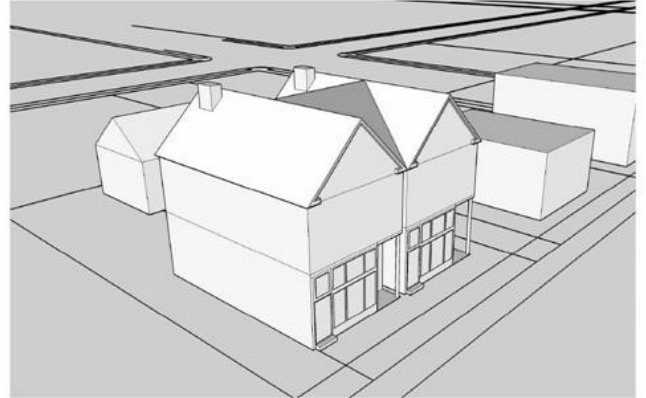

Typical Live-Work Building



(5) Residential/Commercial Conversion.

- (a) Building Type. A former single-family dwelling converted to commercial or office use. The front yard generally remains as landscaped open space or courtyard; parking must be in the rear. The building form remains residential in character; ground floor windows and doors may be enlarged for improved visibility and access.
- (b) Access and Entry. Principal entry to each ground floor unit shall be a direct entrance from the primary abutting street.
- (c) Parking. Parking shall be located behind the building or in a separate common off-street parking facility. Side yard parking may be acceptable if no other alternatives exist.
- (d) Frontage and Design. The residential form of the building shall generally be maintained. Porch, stoop or patio frontage may be acceptable. Accessibility may be improved through changes in entrance grade or other means.

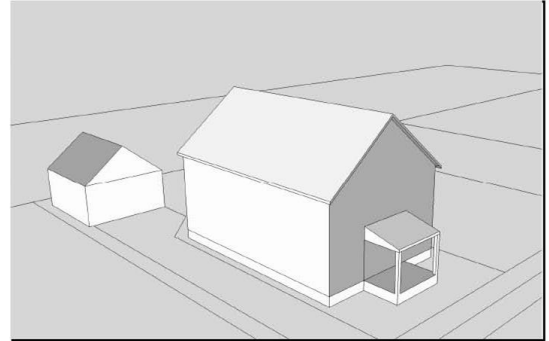

Typical Residential / Commercial Conversion



(6) Podium Building.

- (a) Building Type. A multi-story mixed-use building in which the upper stories are stepped back from a lower base, to provide outdoor terraces, to avoid excessive shadowing of streets or public spaces, or to preserve important views.
- (b) Access and Entry. One or more ground floor entrances from the primary abutting street shall be provided.
- (c) Parking. Parking shall be located behind each building, under the building, or in a common parking court in the interior of a block. Parking may be also be located within a side yard provided that it occupies no more than forty percent (40%) of the frontage along the primary abutting street. Structured parking at ground floor level shall not be visible from the front façade of the building.
- (d) Massing and Articulation. Maximum building length along the primary abutting public street shall not exceed one hundred sixty (160) feet without a significant articulation of the facade. Facades facing a public street shall be vertically articulated at a minimum interval of forty (40) feet.

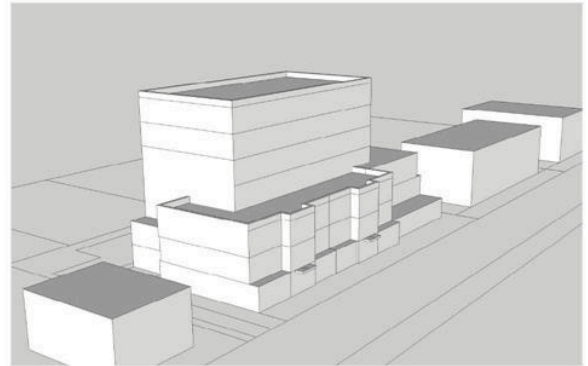

Typical Podium Building



(7) Flex Building.

- (a) Building Type. A variable building type at least two stories in height, designed to accommodate a variety of uses, including combinations of office, retail, lodging, and/or residential. A principal entrance should be oriented to the primary abutting street.
- (b) Access and Entry. One or more ground floor entrances from the primary abutting street shall be provided.
- (c) Parking. Parking shall not be located between the building's front façade and the street. Parking may be located behind the rear plane of the principal building on the lot, or within a side yard, provided that no more than seventy (70) feet of lot frontage along the primary abutting street is occupied by parking or driveways.

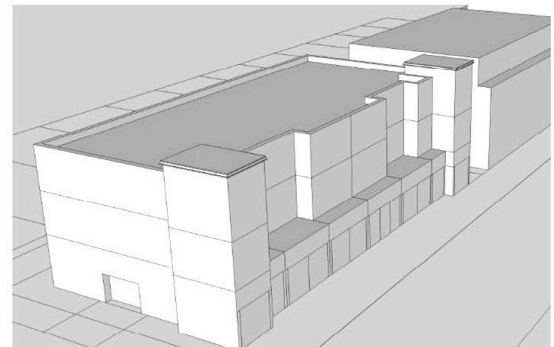

Typical Flex building

Parking may also be wholly or partially underground, or in a common parking area in the interior of a block.

- (d) Massing and Articulation. Maximum building length along the primary abutting public street shall not exceed one hundred sixty (160) feet without a significant articulation of the facade. Facades facing a public street shall be vertically articulated at a minimum interval of forty (40) feet



(8) Industrial Building.

- (a) Building Type. A large open-floor-plate building that allows maximum flexibility in the types of uses accommodated. Buildings are typically characterized by a tall single story or first floor, and may be set on a raised base to facilitate industrial loading and unloading.
- (b) Access and Entry. One or more ground floor entrances from the primary abutting street shall be provided.
- (c) Parking. Parking may be provided on any side of the building. Loading activities shall be situated to the side or rear of the building.
- (d) Massing and Articulation. Facades facing a public street shall be vertically articulated at a minimum interval of 60 feet.

