

**CITY OF MADISON
RETAIL IMPROVEMENT GRANT PROGRAM**



Strengthening Downtown Independent Retail

Department of Planning & Community & Economic Development
Economic Development Division
215 Martin Luther King Jr., Boulevard
Ruth Rohlich 267-4933
rrohlich@cityofmadison.com

PROGRAM APPLICATION

Applicant: CASIMIRO SALAS Phone: 608-255-2114
 Business Name: TRIANGLE MARKET
 Building Name: _____
 Business Address: 302 STATE ST MADISON Zip Code 53703
 E-mail Address: trianglemarket@gmail.com
 Property Owner: Wayne Dishaw
 Address: 2344 Hidden Meadows Sun Prairie WI
 Name of Grantee: _____
 Lease Terms: _____
 Definition of Project Scope: REPLACE window glass; Frame, and door
REPLACE window wood support top and bottom

ATTACHMENT

Please provide photographs and copy of lease, land contract, or deed. Tenants must provide owner's written authorization.

PROJECT BUDGET

List Individual Project Elements: (new flooring, new lighting, restrooms, etc.)	Total Cost	Grant \$	Private \$
<u>Windows + Door</u>	<u>10066.81</u>	<u>5008.40</u>	<u>5008.41</u>
<u>Windows, horizontal Dividers</u>	<u>474.</u>	<u>237.</u>	<u>237.</u>
Total:	<u>10490.81</u>	<u>5245.40</u>	<u>5245.41</u>

CITY OF MADISON
RETAIL IMPROVEMENT GRANT PROGRAM



Strengthening Downtown Independent Retail

Department of Planning & Community & Economic Development
Economic Development Division
215 Martin Luther King Jr., Boulevard
Ruth Rohlich 267-4933
rrohlich@cityofmadison.com

Contractor/Supplier: MARTIN GLASS
Address: 2323 Atwood Ave MADISON WI

ATTACHMENT

* Bids, estimates, and/or contracts, product brochures, locator map and design drawings, if appropriate.

REMARKS _____

APPLICANT'S CERTIFICATION

The Applicant certifies that all information in this application and all information furnished in support of this application is given for the purpose of obtaining a grant under the City of Madison Façade Grant Program and is true and complete to the best of the applicant's knowledge and belief.

Signature: Casimiro Salca Date: Sept 7 2017
Signature: _____ Date: _____

Please send this completed application and accompanying materials:

Economic Development Division
Attn: Ruth Rohlich
215 Martin Luther King Jr. Boulevard, Room 312
P.O. Box 2983
Madison, WI 53701-2983



Martin Glass

2323 Atwood Avenue
MADISON, WI 53704

PROPOSAL

Name / Address Triangle Market 302 State Street Madison, WI 53703	Date 4/6/2017	Estimate # 162738	Terms Net 30
--	------------------	----------------------	-----------------

P.O. # or Location

Description	Qty	Total
<p>We propose to remove your existing glass storefront and replace it with 2" x 4 1/2" clear anodized framing and insulated glass units in the configuration that currently exists. Also, a 42" x 84" clear anodized door and frame with 10" bottom, medium stiles, dead bolt lock, closer and sweep will be installed. This proposal is contingent upon approval from the City of Madison. Installed Price Including Materials, Applicable Taxes and Labor.</p> <p style="text-align: right;">10,016.81</p> <p>There is an option to have horizontal dividers in the windows at 28" from bottom. All glass below the dividers is quoted with tempered glass units for durability. The add-on cost for this option is \$474.00 <input type="checkbox"/> Approve dividers with tempered glass below divider. <input type="checkbox"/> Decline option for dividers with tempered glass below divider.</p> <p>There is an option to use dark bronze commercial metals. This option will add 5% to the project. <input type="checkbox"/> Approve dark bronze metals for an additional 5% cost. <input checked="" type="checkbox"/> Decline the use of dark bronze metals. Install clear anodized metals.</p> <p>Down payment is \$5000. To proceed, please sign and return a copy of this proposal with your down payment. Thank you. Sales Tax</p>		0.00

TOTAL \$10,016.81

All material is guaranteed to be as specified, and the above work to be performed in accordance with the drawings and/or specifications submitted for above work, and completed in a substantial workmanlike manner.

Any alteration or deviation from above specifications involving extra costs will be executed only upon written order and will become an extra charge over and above the estimate. All oversized units (exceeding 50 sq. ft.) tempered lites and IG units will be sold "as is" for any and all visual characteristics. Window washing is not part of the service provided by Martin Glass and is not included in installed prices.

The proposed work is a Special Order. Once ordered, it cannot be cancelled. The party ordering the work is responsible for payment.

~~This proposal may be withdrawn by us if not accepted within 30 days.~~

The above prices, specifications and conditions are satisfactory and are hereby accepted. You are authorized to do the work as specified. Payments will be made as outlined above.

Respectfully submitted

Signature Casimiro Soares Date 4/7/17

Martin Glass

Date

File # 1-1-21-20
2100 Cottage Grove Road
Maple, MN 55120
Phone: 763-429-9999

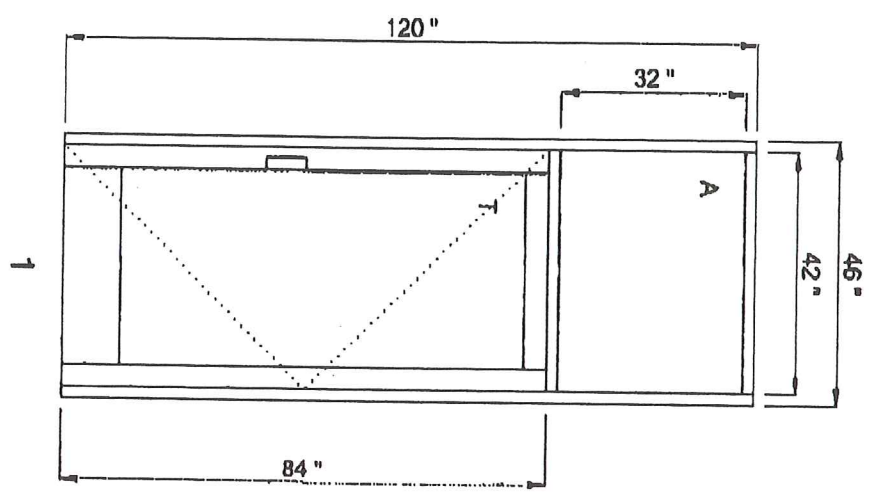

Hillestad Glass - Tingle - 001 - A.dxf (1 Thus)
Frame: (C1/DB/1P) T14000 : Storefront :
2 x 4 - 1/2 : Flush Glaze : T14055 subsill

710 C
Medison, 117-8244
(800) 241-8888

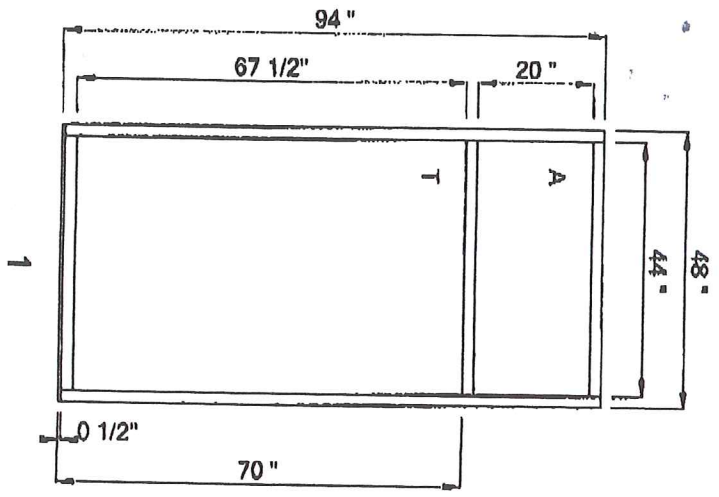

Hillestad Glass - Tingle - 003 - C.dxf (1 Trus)
Frame: (C1/DB/1P) T14000 : Storefront :
2 x 4-1/2 : Flush Glaze : T14055 substill