

VARIANCE FEES

~~MGO \$50.00~~
COMM \$490.00
 Priority - Double above

PETITION FOR VARIANCE APPLICATION

City of Madison
Building Inspection
Division
 215 Martin Luther King Jr. Blvd.
 Madison, WI 53703
 (608) 266-4568

Amount Paid 490 8/1/16 FMR

Name of Owner Michael Hannon	Project Description Tenant interior upfit; A-2; Pizzeria	Agent, architect, or engineering firm Agent: L2M, Inc.
Company (if applies) Colmont Restaurant Group		No. & Street 811 Cromwell Park Dr.; Suite 113
No. & Street 2480 Route 97, Suite 12	Tenant name (if any) Lotsa - Stone Fired Pizza	City, State, Zip Code Glen Burnie, MD 21061
City, State, Zip Code Glenwood, MD 21738	Building Address 506 State Street	Phone 410-863-1302 x 130
Phone 410-489-0004 x 1101	Madison, Dane County	Name of Contact Person Scot Loiseau
e-mail mhannon@lotsa.com		e-mail sloiseau@L2M.com

1. The rule being petitioned reads as follows: (Cite the specific rule number and language. Also, indicate the nonconforming conditions for your project.)

- IBC 2009; 1009.2 - required headroom clearance is: 6'-8"; provided at existing stair: 5'-10"
- IBC 2009; 1009.4.2 - maximum stair riser is: 7"; provided at existing stair: 8"
- IBC 2009; 1009.4.2 - Minimum stair tread is: 11"; provided at existing stair: 10"

2. The rule being petitioned cannot be entirely satisfied because:

the constraints (dimensions) of the existing building footprint, and the presence of an existing egress pathway for an existing second floor tenant, in conjunction with the location of existing utilities passing through the subject area serving this and adjacent spaces, make more significant upgrades to the existing stair technically infeasible

3. The following alternatives and supporting information are proposed as a means of providing an equivalent degree of health, safety, and welfare as addressed by the rule:

The applicant intends, as illustrated on the attached sketch sheets to close-in the existing open risers; the existing handrails will be replaced with handrails that comply with applicable dimensions and clearances for a new stair; applicant will direct general contractor, if variance is approved, to modify framing in the area of the lowest headroom to provide as much additional clearance as may be provided without sacrificing structural integrity of said framing; final available headroom to be determined at time of inspections, though headroom is not likely to satisfy 1009.2; further, while not specifically related to the referenced code sections, the applicant has improved the fire-resistance rating of the existing floor ceiling assembly separating the existing first and second floor tenants;

Note: Please attach any pictures, plans, or required position statements.

VERIFICATION BY OWNER – PETITION IS VALID ONLY IF NOTARIZED AND ACCOMPANIED BY A REVIEW FEE AND ANY REQUIRED POSITION STATEMENTS.

Note: Petitioner must be the owner of the building. Tenants, agents, contractors, attorneys, etc. may not sign the petition unless a Power of Attorney is submitted with the Petition for Variance Application.

Michael Hannon, CFO _____, being duly sworn, I state as petitioner that I have read the foregoing petition, that I believe it to be true, and I have significant ownership rights in the subject building or project.

Signature of owner 	Subscribed and sworn to before me this date: <u>21st day of July 2016</u>
Notary public <u>Debbie Billings</u>	My commission expires: <u>2/25/2019</u>

NOTE: ONLY VARIANCES FOR COMMERCIAL CODES ARE REQUIRED TO BE NOTARIZED

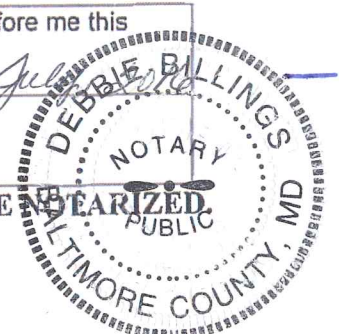

City of Madison Fire Department Position Statement

Owner: Michael Hannon	Project Name: Lotsa – Stone Fired Pizza	Contact: Scot Loiseau L2M, Inc
Address: Colmont Restaurant Group 2480 Route 97 Suite 12 Glenwood, MD 21738	Building Location: 506 State Street Madison, WI	Address: 811 Cromwell Park Dr Suite 113 Glen Burnie, MD 21061
Owner Phone: 410-489-0004 x1101 Email: mhannon@lotsa.com	Building Occupancy or Use: A-2 Assembly Pizzeria	Phone: 410-863-1302 x130 Email: sloiseau@L2M.com

Rule Being Petitioned: IBC 1009.2 Headroom clearance, 1009.4.2 Stair tread & riser

I have read the application for variance and recommend: (check appropriate box)

Approval
 Conditional Approval
 Denial
 No Comment

- MFD will defer to past acceptable tolerances from the Board of Appeals.

Name of Fire Chief or Designee (type or print) Bill Sullivan, Fire Protection Engineer	
City of Madison Fire Department	Telephone Number 608-261-9658
Signature of Fire Chief or Designee 	Date Signed July 29, 2016

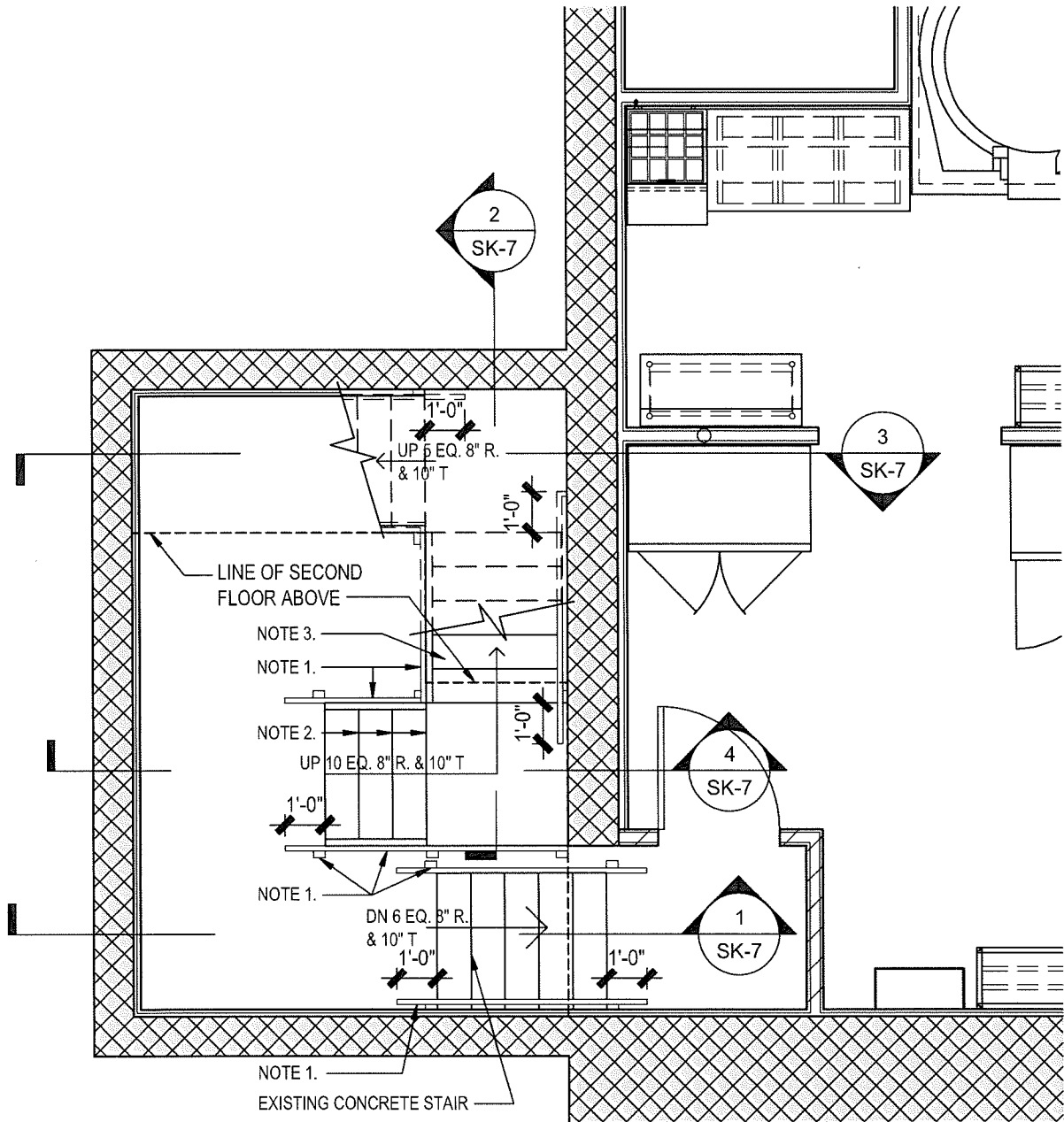

NOTES:

1. PROVIDE NEW WOOD RAILING, BALUSTERS AND SUPPORT AS SHOWN.
2. CLOSE IN OPEN RISERS IN EXISTING WOOD STAIRS WITH PLYWOOD, SEE SECTIONS AND DETAILS FOR MORE INFORMATION.
3. PROVIDE NEW RUBBER TREADS, SEE DETAIL SK-7.5

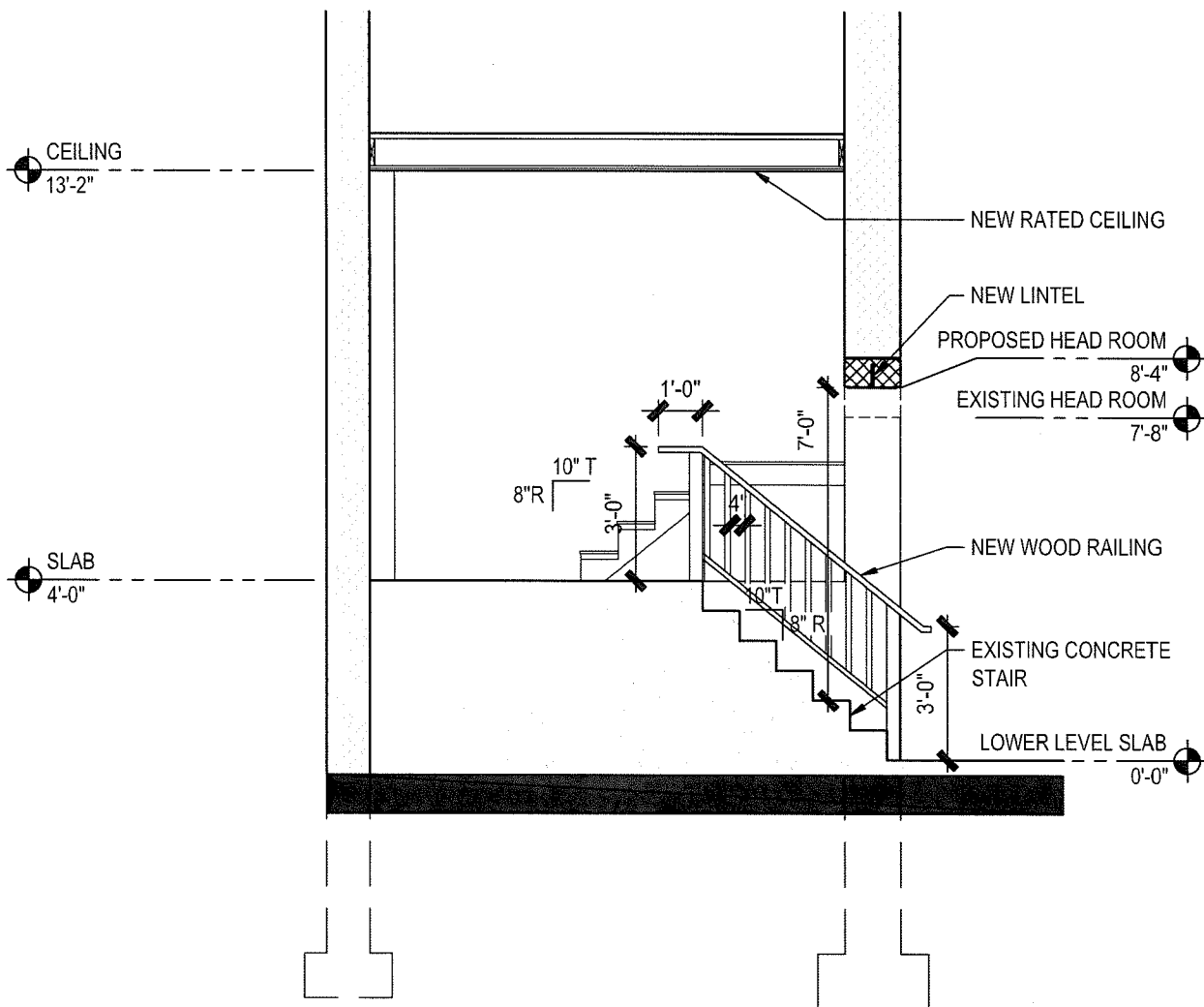

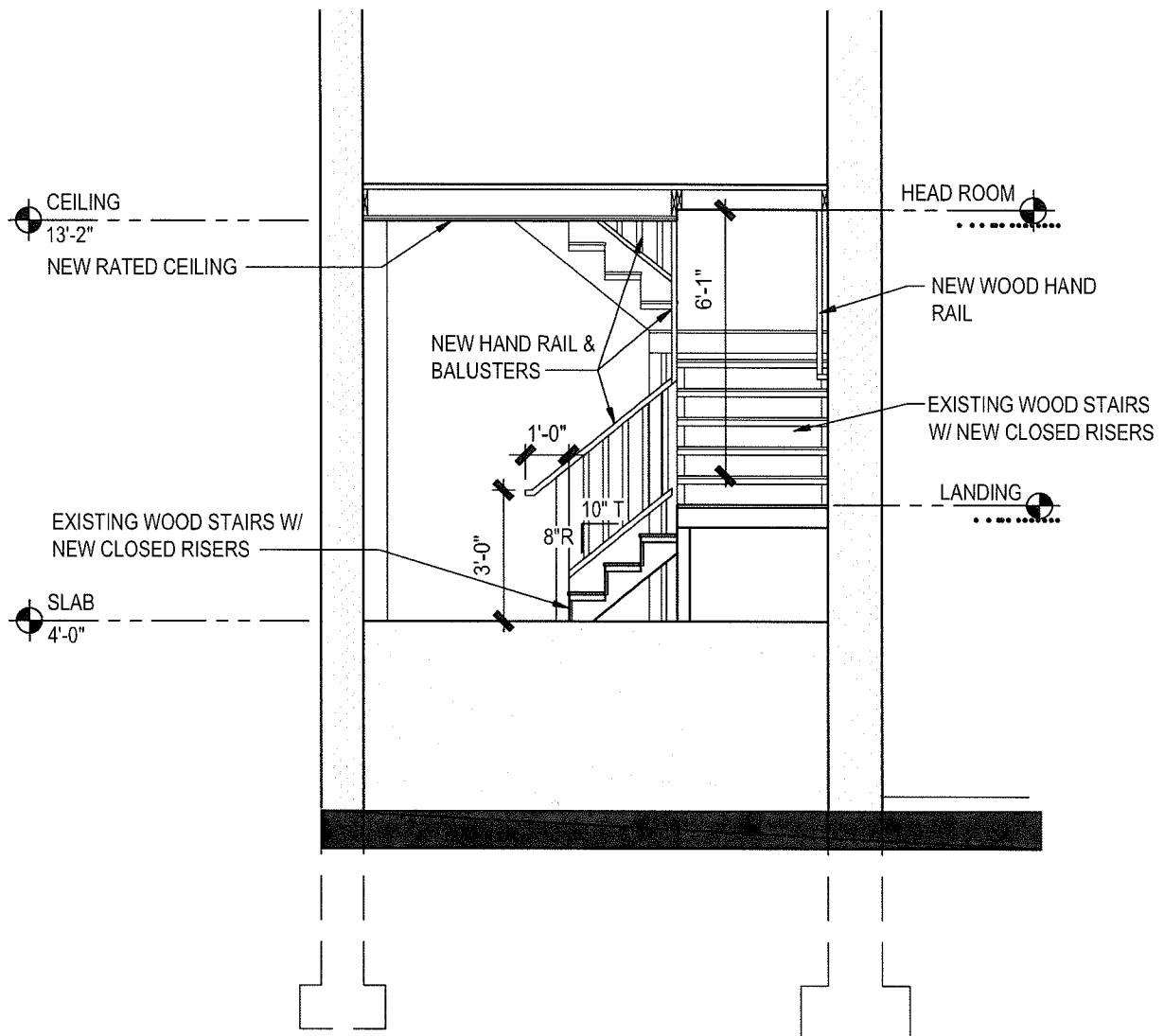

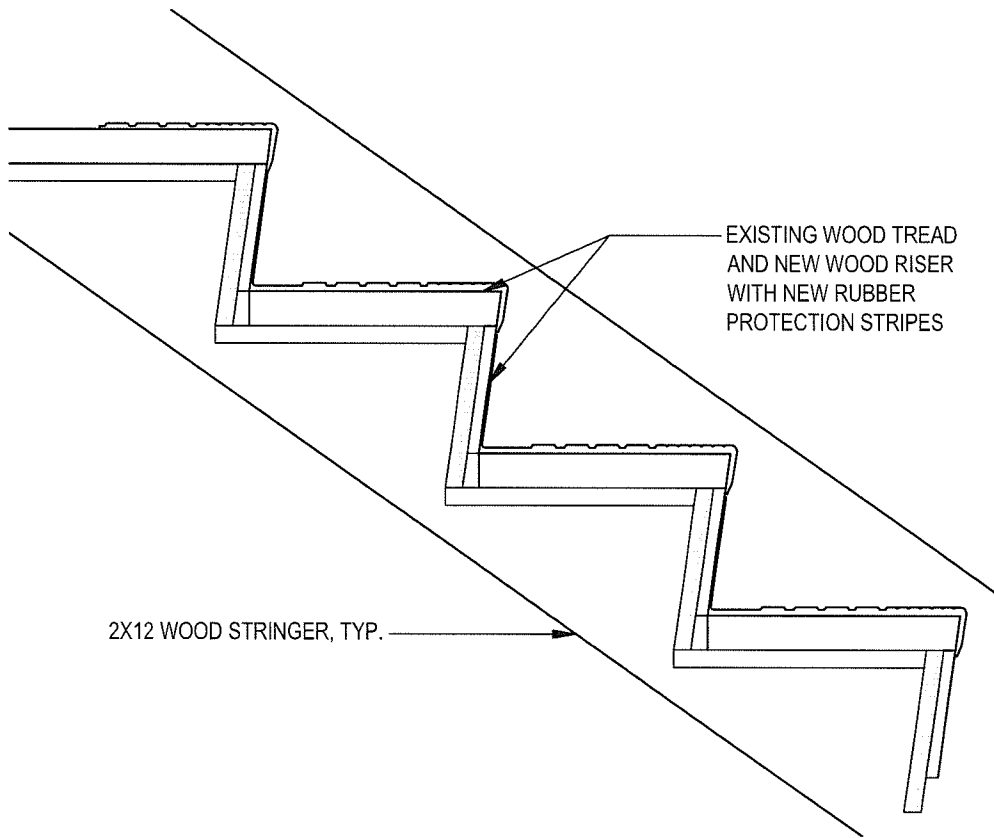

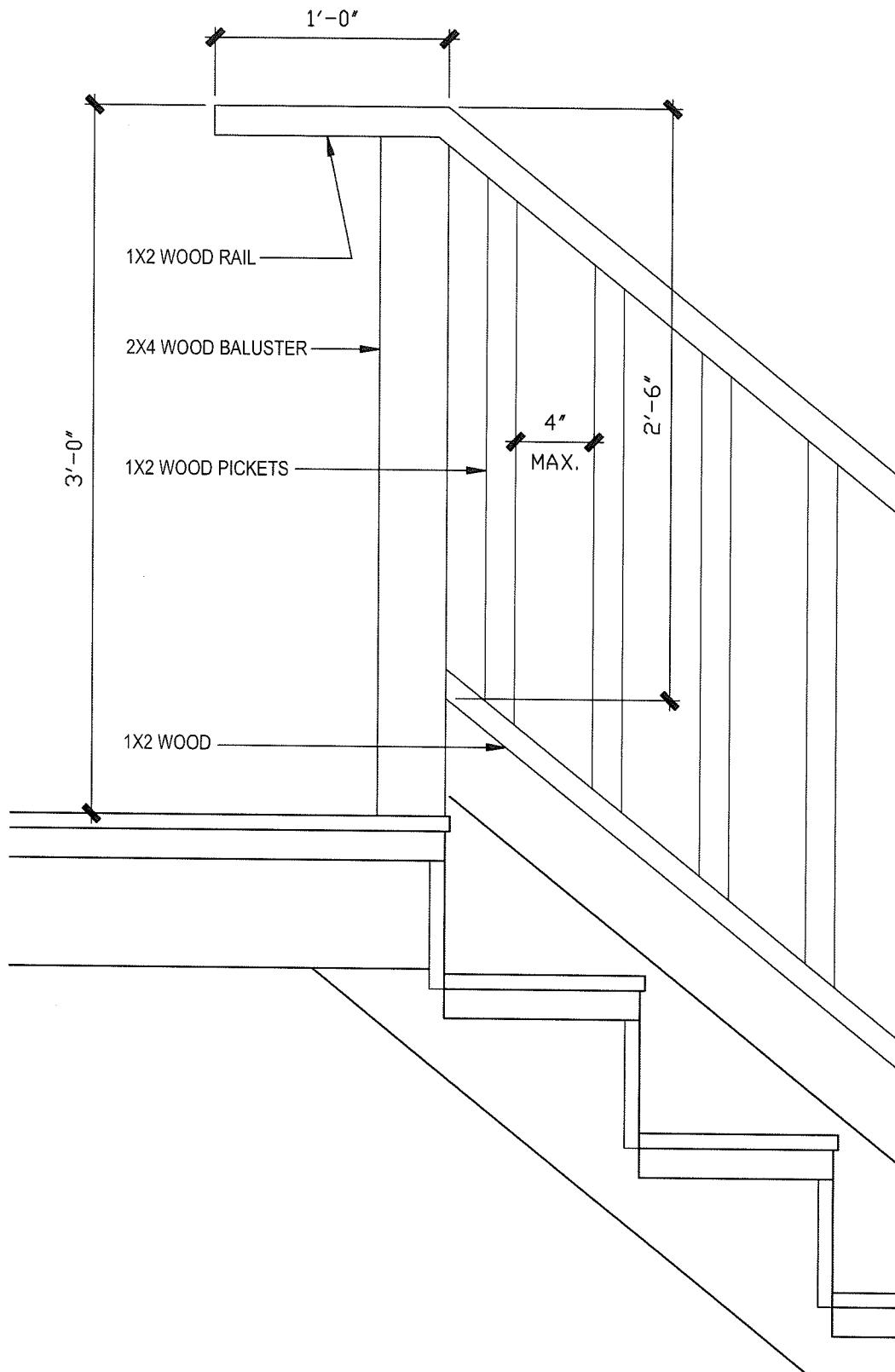



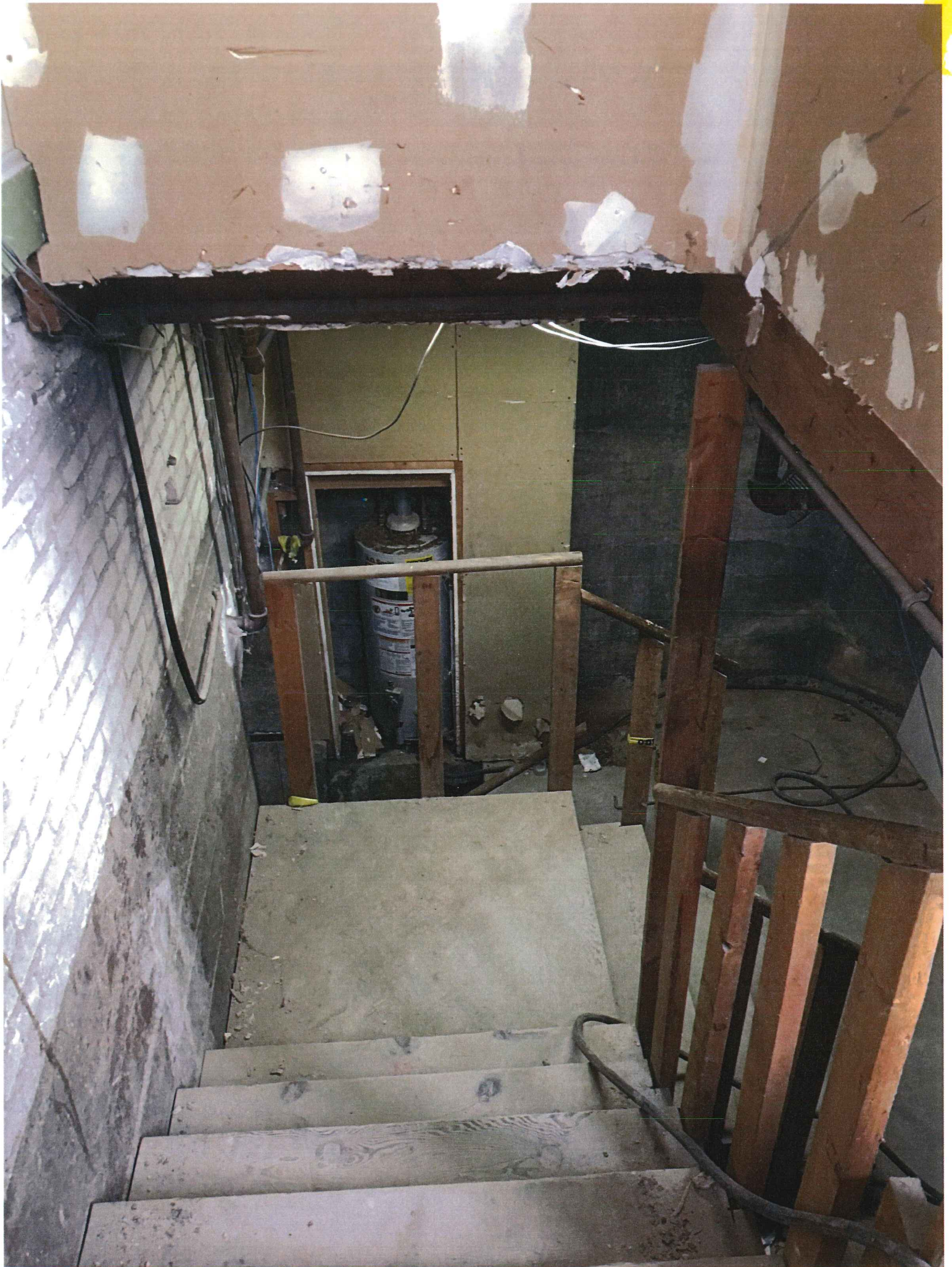



City of Madison Fire Department Position Statement

Owner: Michael Hannon	Project Name: Lotsa – Stone Fired Pizza	Contact: Scot Loiseau L2M, Inc
Address: Colmont Restaurant Group 2480 Route 97 Suite 12 Glenwood, MD 21738	Building Location: 506 State Street Madison, WI	Address: 811 Cromwell Park Dr Suite 113 Glen Burnie, MD 21061
Owner Phone: 410-489-0004 x1101 Email: mhannon@lotsa.com	Building Occupancy or Use: A-2 Assembly Pizzeria	Phone: 410-863-1302 x130 Email: sloiseau@L2M.com

Rule Being Petitioned: IBC 1009.2 Headroom clearance, 1009.4.2 Stair tread & riser

I have read the application for variance and recommend: (check appropriate box)

Approval
 Conditional Approval
 Denial
 No Comment

- MFD will defer to past acceptable tolerances from the Board of Appeals.

Name of Fire Chief or Designee (type or print) Bill Sullivan, Fire Protection Engineer	
City of Madison Fire Department	Telephone Number 608-261-9658
Signature of Fire Chief or Designee 	Date Signed July 29, 2016