

**APPLICATION FOR
URBAN DESIGN COMMISSION
REVIEW AND APPROVAL**

**AGENDA ITEM # _____
Project # _____
Legistar # _____**

DATE SUBMITTED: <u>February 13, 2013</u>	Action Requested
UDC MEETING DATE: <u>March 6, 2013</u>	<input type="checkbox"/> Informational Presentation
	<input type="checkbox"/> Initial Approval and/or Recommendation
	<input checked="" type="checkbox"/> Final Approval and/or Recommendation

PLEASE PRINT!

PLEASE PRINT!

PROJECT ADDRESS: 6733 Fairhaven Road

ALDERMANIC DISTRICT: District 7

OWNER/DEVELOPER (Partners and/or Principals)	ARCHITECT/DESIGNER/OR AGENT:
<u>Fairhaven Court, LLC</u>	<u>Architectural Design</u>
<u>Kevin Kavanaugh, Jim Anderson,</u>	<u>Consultants, Inc.</u>
<u>Gregg Shimanski</u>	<u>Russell A. Eilers, AIA</u>

CONTACT PERSON: Russell A. Eilers, AIA

Address: 30 Wisconsin Dells Parkway
Lake Delton, WI 53940

Phone: 608-254-6181

Fax: 608-254-2139

E-mail address: r.eilers@adcidesign.com

TYPE OF PROJECT:

(See Section A for:)

- Planned Unit Development (PUD)
- General Development Plan (GDP)
- Specific Implementation Plan (SIP)
- Planned Community Development (PCD)
- General Development Plan (GDP)
- Specific Implementation Plan (SIP)
- Planned Residential Development (PRD)
- New Construction or Exterior Remodeling in an Urban Design District * (A public hearing is required as well as a fee)
- School, Public Building or Space (Fee may be required)
- New Construction or Addition to or Remodeling of a Retail, Hotel or Motel Building Exceeding 40,000 Sq. Ft.
- Planned Commercial Site

(See Section B for:)

- New Construction or Exterior Remodeling in C4 District (Fee required)

(See Section C for:)

- R.P.S.M. Parking Variance (Fee required)

(See Section D for:)

- Comprehensive Design Review* (Fee required)
- Street Graphics Variance* (Fee required)
- Other _____

*Public Hearing Required (Submission Deadline 3 Weeks in Advance of Meeting Date)

Where fees are required (as noted above) they apply with the first submittal for either initial or final approval of a project.

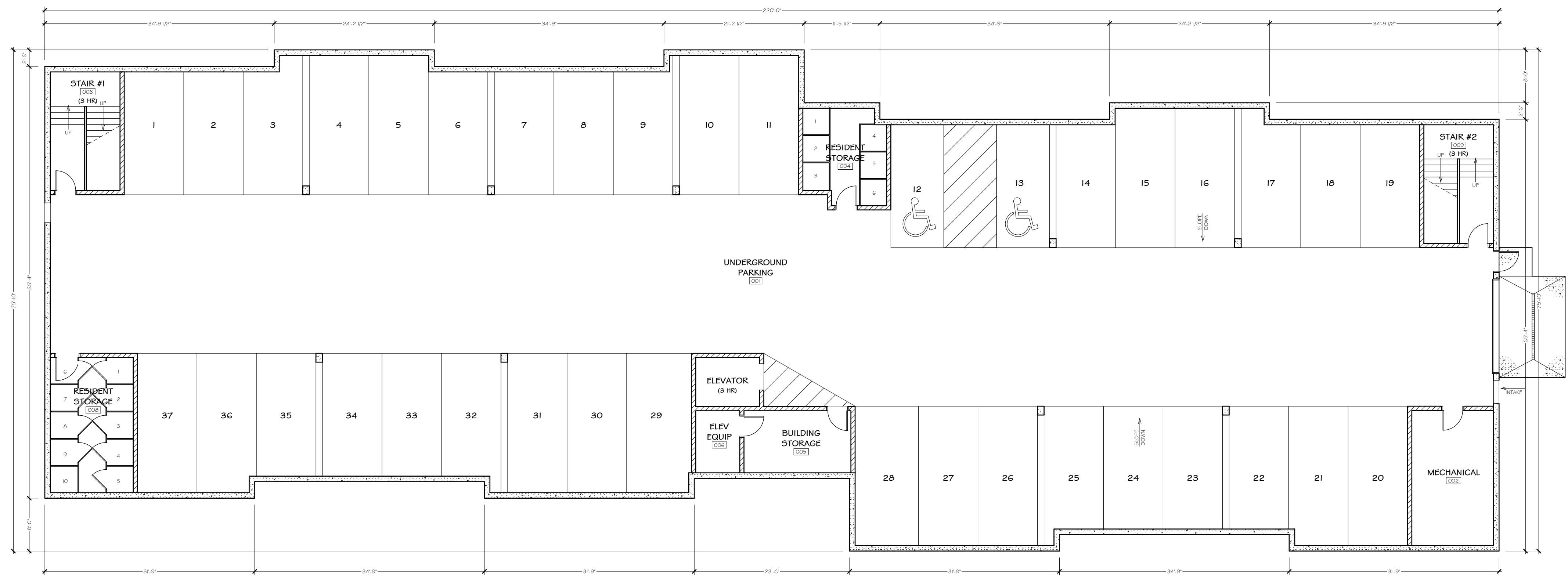

BASEMENT FLOOR PLAN

NOT TO SCALE



FIRST FLOOR PLAN

NOT TO SCALE

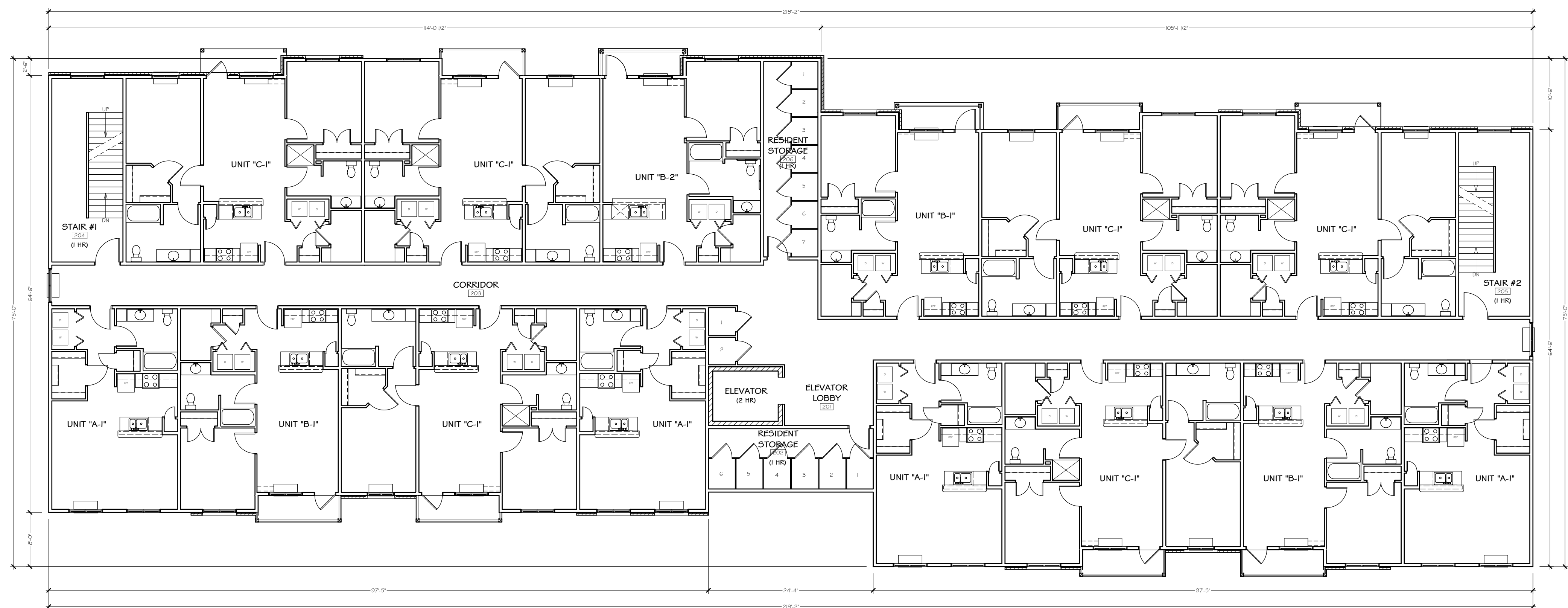

SECOND FLOOR PLAN

NOT TO SCALE

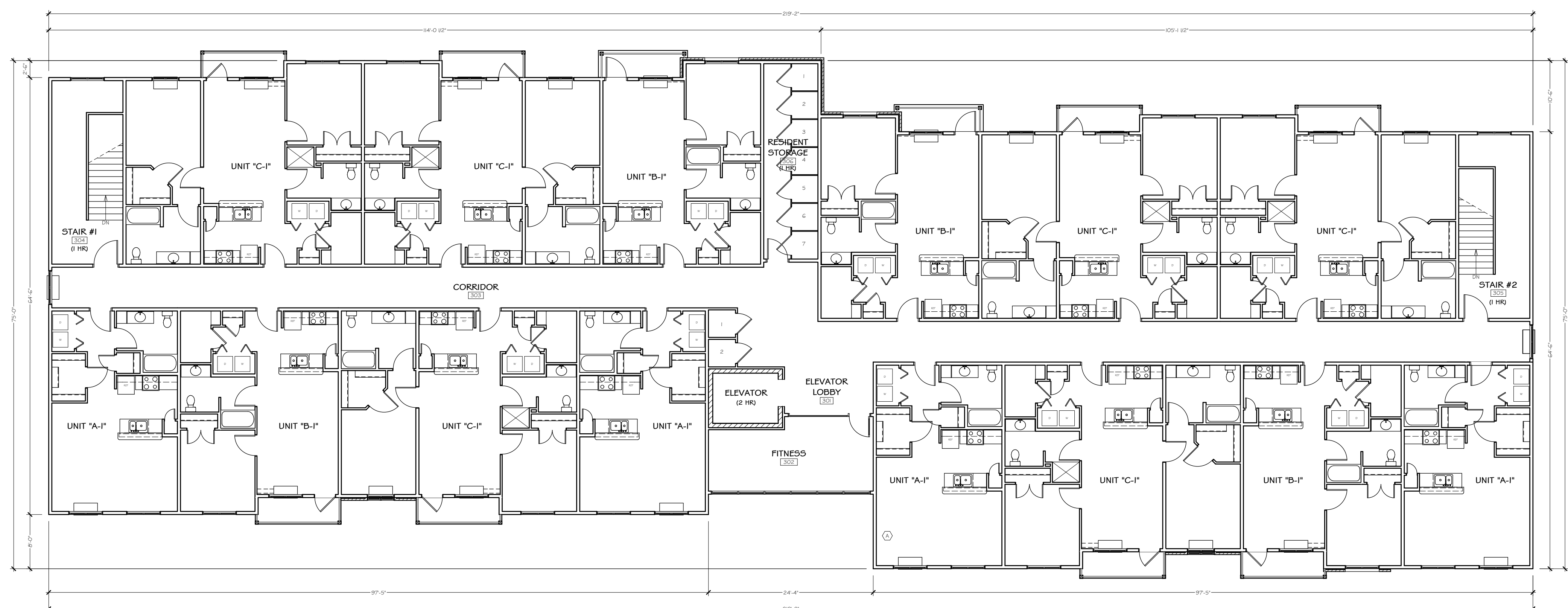

THIRD FLOOR PLAN

NOT TO SCALE



Architectural Design Consultants, Inc.



ELEVATION A

SCALE: 1" = 10'

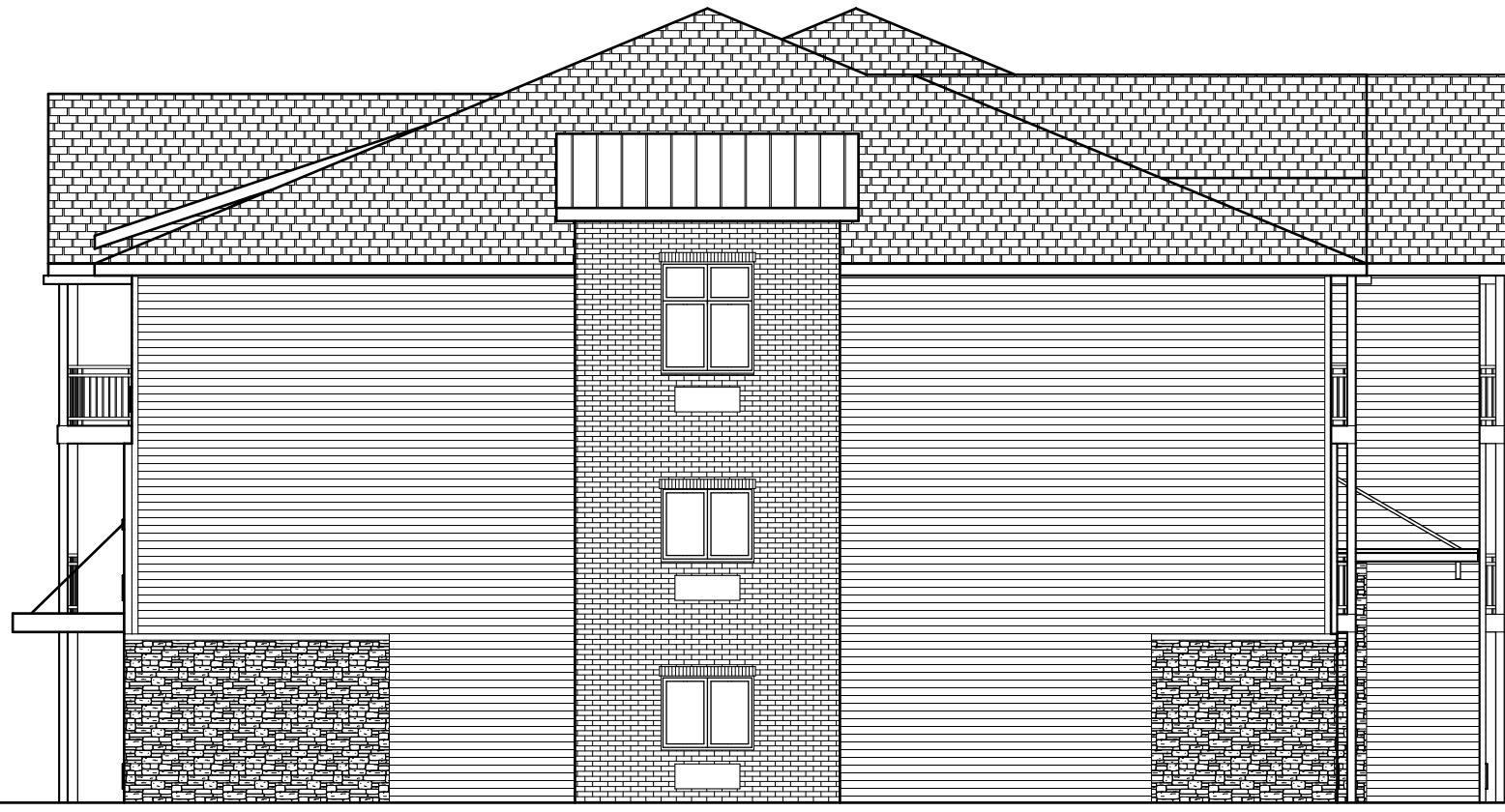

ELEVATION B

SCALE: 1" = 10'



ELEVATION C

SCALE: 1" = 10'

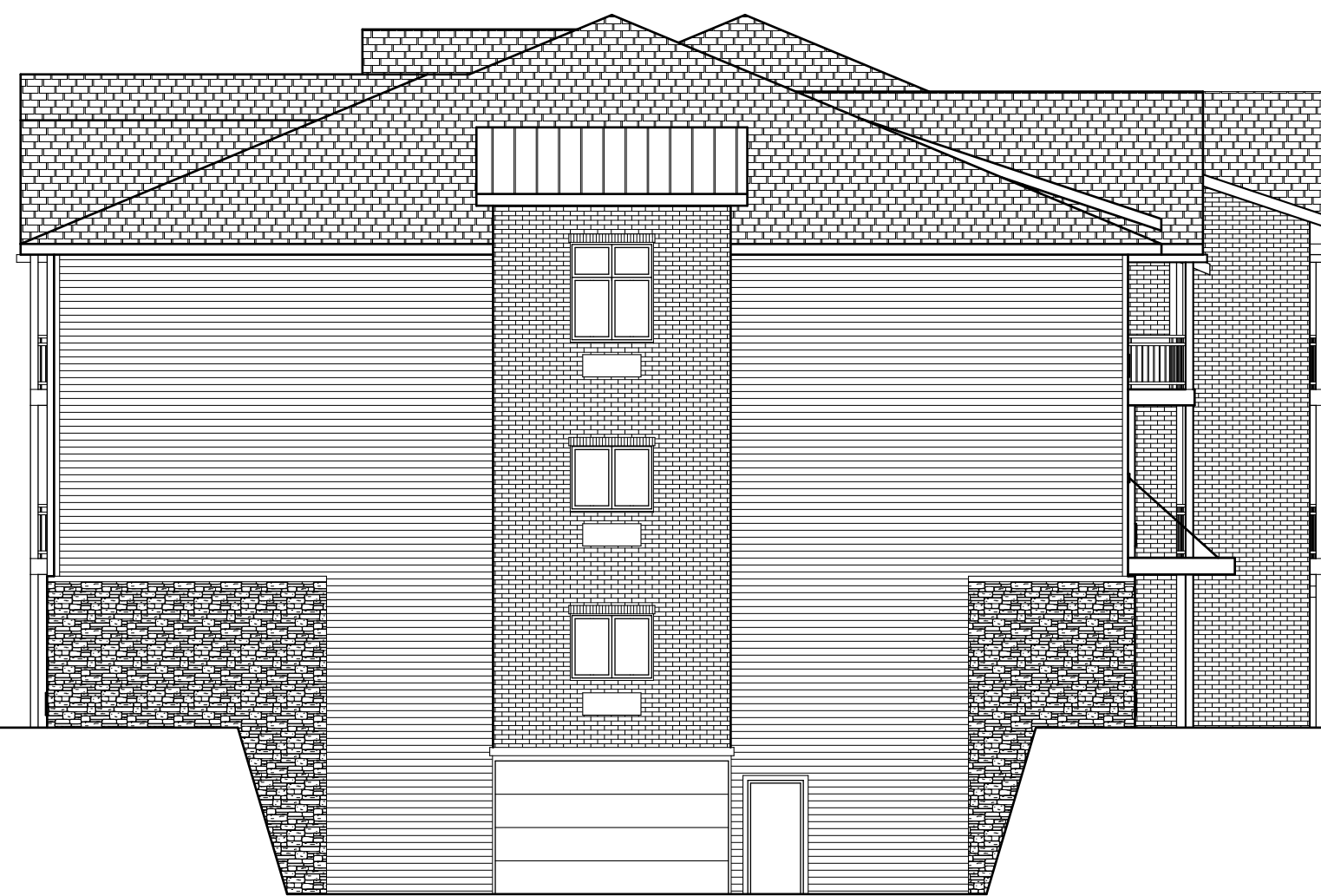

ELEVATION D

SCALE: 1" = 10'

EXTERIOR COLOR SCHEDULE

MATERIAL	COLOR
BRICK	RED
SIDING	SANDSTONE BEIGE
STONE	SUNHILL BLEND
SHINGLES	DRIFTWOOD
SOFFIT/FASCIA	WHITE
WINDOWS/DOORS	WHITE
BALCONIES/TRIM	WHITE

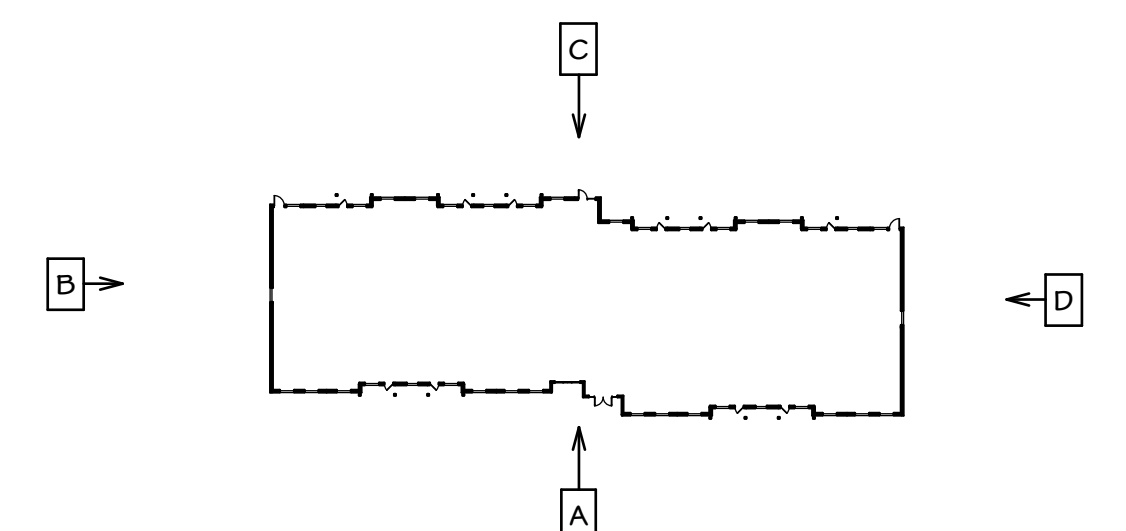

KEY PLAN



ADCI
Architectural Design
Consultants, Inc.

This document contains confidential or proprietary information of Architectural Design Consultants, Inc. Neither this document nor the information herein is to be reproduced, distributed, used or disclosed either in whole or in part except as specifically authorized by Architectural Design Consultants, Inc.

FAIRHAVEN COURT - APARTMENT BUILDING

MADISON, WI

2-12-13



Fairhaven Court Apartments - February 12, 2013



Architectural Design
Consultants, Inc.



Fairhaven Court Apartments - February 12, 2013



Architectural Design
Consultants, Inc.



ELEVATION "A"



ELEVATION "C"

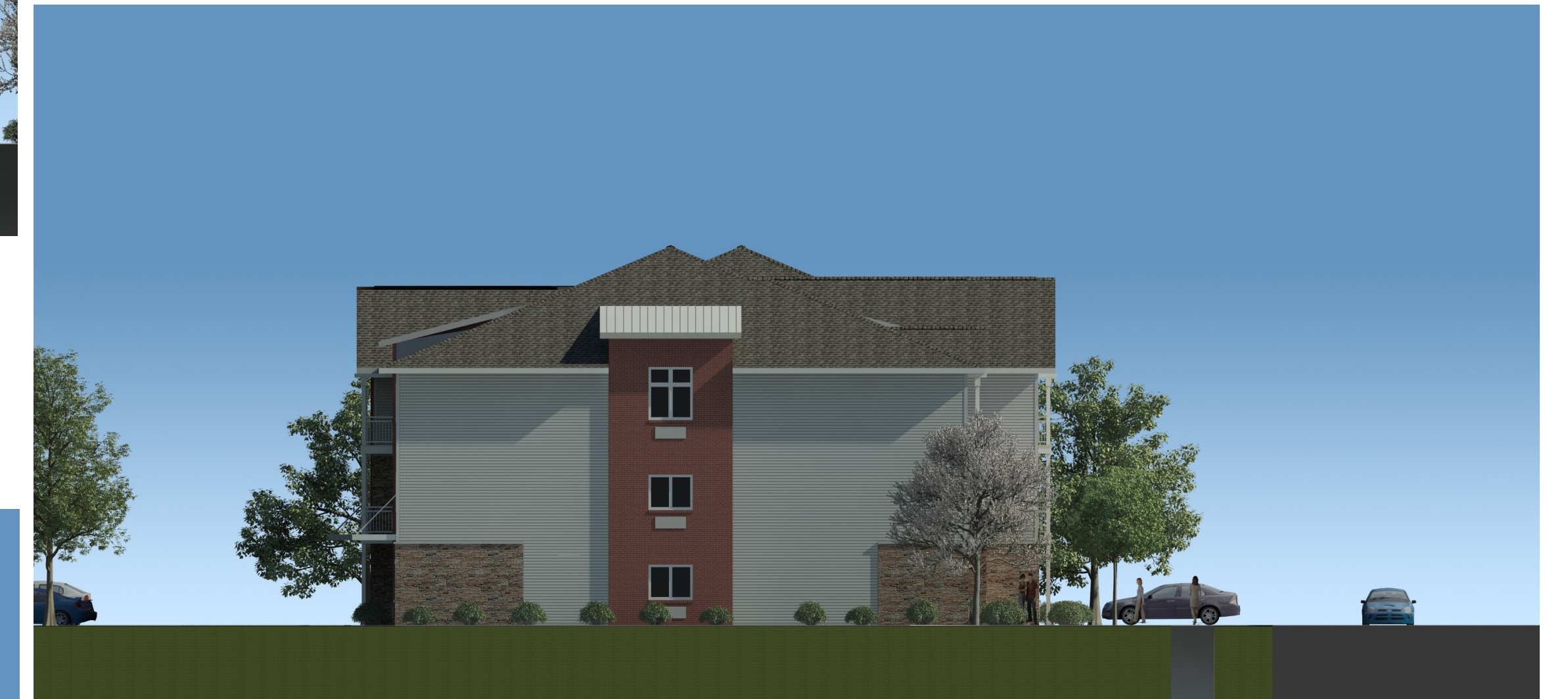

ELEVATION "B"

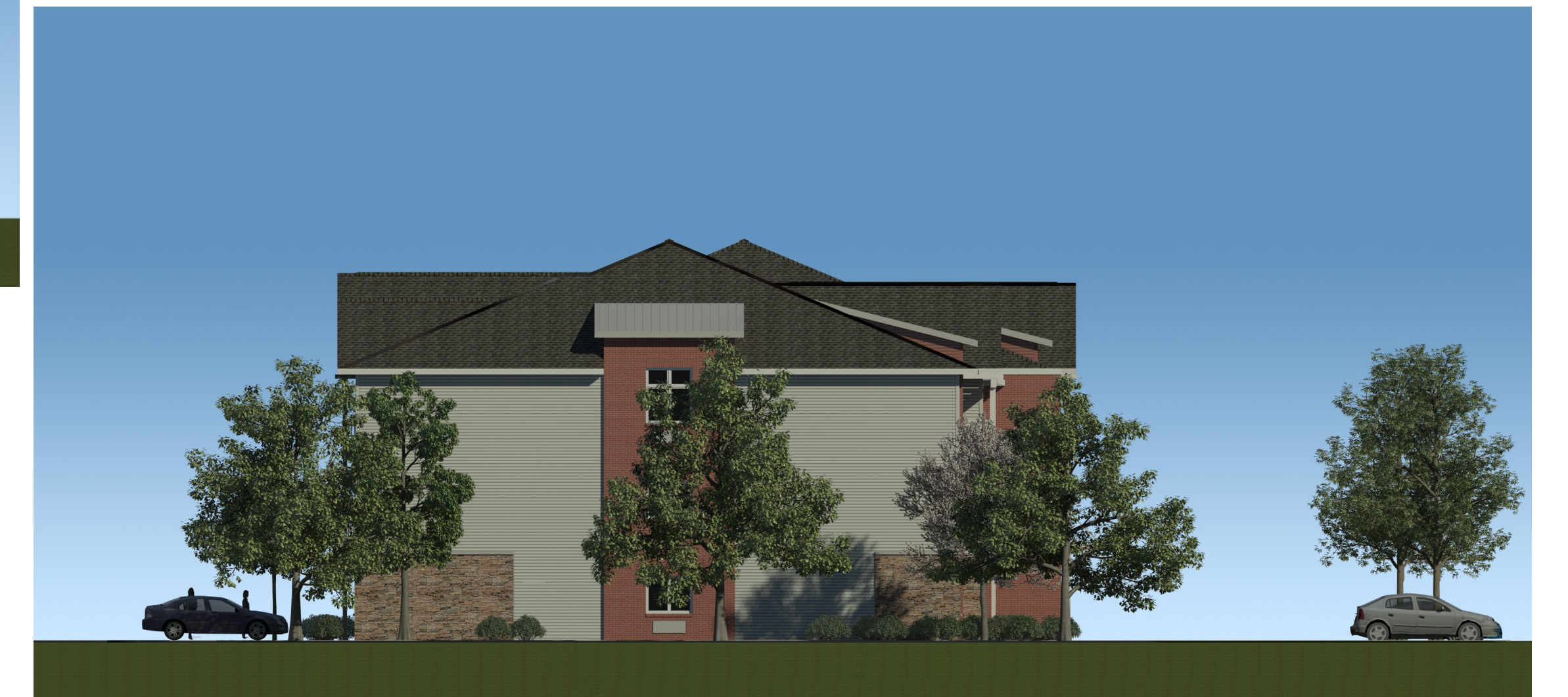

ELEVATION "D"

Fairhaven Court Apartments - February 12, 2013



Architectural Design
Consultants, Inc.



Locator
Southwest 14, Section 12
T08N, R12E

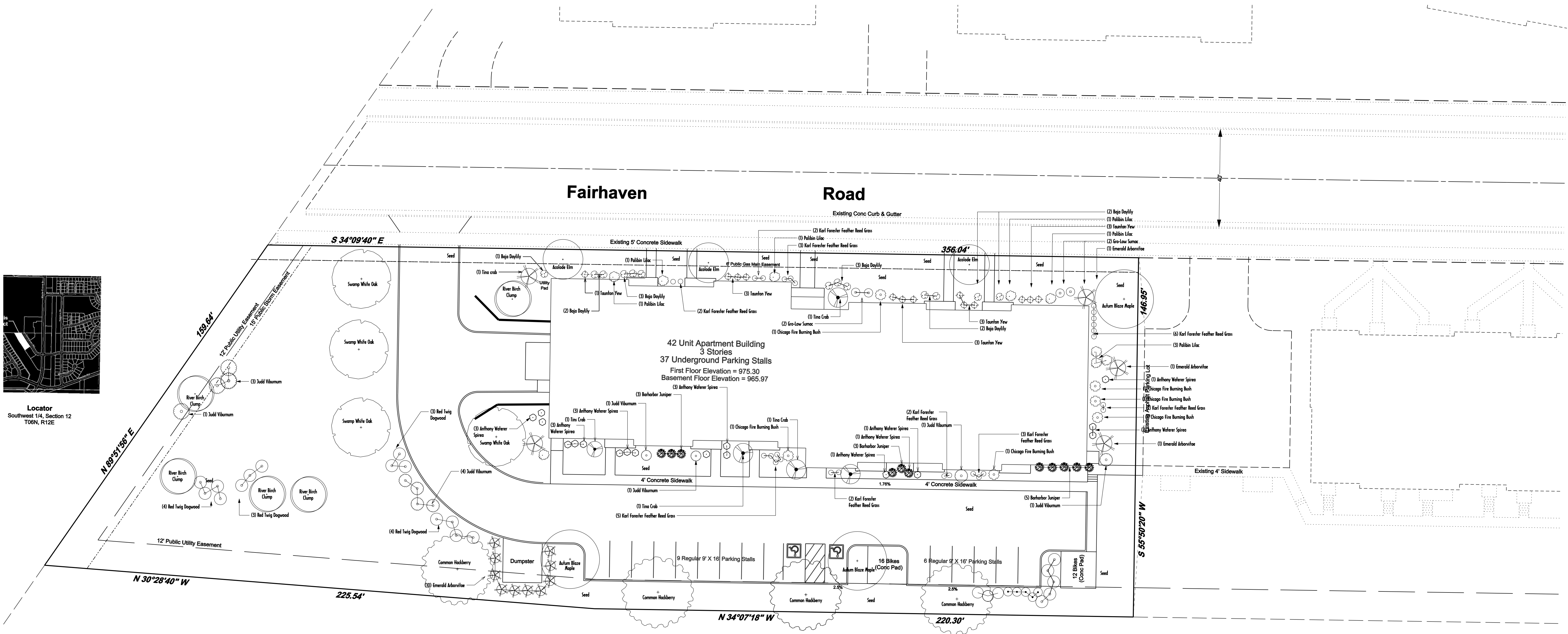

Quantity	Common Name	Planting Size
4	Swamp White Oak	2" BB
3	Acolode Elm	1-3/4" BB
4	Autumn Blaze Maple	2" BB
4	Common Hackberry	2" BB
5	River Birch Clump	6" BB
4	Tina Crab	4" BB
15	Emerald Arborvitae	4" BB
5	Common Witch Hazel	#5 CONT
22	Red Twig Dogwood	#7 CONT
11	Judd Viburnum	#7 CONT
8	Chicago Fire Burning Bush	3" BB
11	Paibin Lilac	#5 CONT
18	Anthony Waterer Spirea	#2 CONT
17	Gro-Low Sumac	#2 CONT
23	Taunton Yew	15" BB
14	Sar Harbor Juniper	#2 CONT
19	Karl Forester Feather Reed Grass	#1 CONT
13	Baja Daylily	#1 CONT

General Notes:

- Individual trees and shrub groupings found along the perimeter of the property as well as those found within lawn areas to receive wood mulch rings and wood mulch beds consisting of a mixture of recycled wood mulch, colored brown.
- "Vinyl Edging" to be Valley View Black Diamond Vinyl Edging or equivalent.
- Areas labeled "washed stone" to receive 1-1/2" washed stone spread to a 3" depth over fabric barrier.
- Seed shall consist of the following mixture:
40% Palmer Ryegrass
20% Baron Bluegrass
20% Nassau Bluegrass
20% Pennlawn Creeping Red Fescue
- Plant beds adjacent to the building(s) to be mulched with 1-1/2" diameter washed stone mulch spread to a 3" depth over fabric barrier

City of Madison	
Landscape Requirements	
Number of Parking Stalls	29
Number of Canopy Trees Required	3
Number of Landscape Points Required	147
Solution	
6 Canopy Trees (2" - 2-1/2") @ 35 points	210
6 Canopy Trees or Small Ornamental Trees (1-1/2" - 2") @ 15 points	
38 Deciduous Shrubs @ 2 points	76
Evergreen Shrubs @ 3 points	
Evergreen Trees (3"t) @ 15 points	
Decorative Wall @ 5 points (Per 10 lf)	
Decorative Fence @ 5 points (Per 10 lf)	
Decorative Earth Berm @ 5 points (Per 10 lf)	
Average Height - 30" @ 5 points	
Average Height - 15" @ 2 points	
Total Points	286

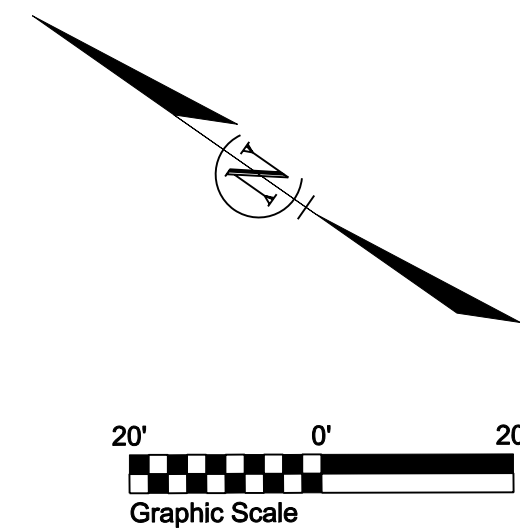

Drawn By: EMS
Checked By: RC
Date: April 6, 2012
Revised:
Plot File: 16037-L
Plot Table: 16037-L

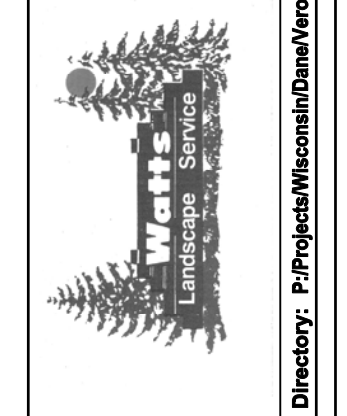

Watts Landscape Service
350 Pioneer Avenue
Verona, Wisconsin, 53593
Phone (608) 833-3535
www.wattslandscape.com

For:
Fairhaven Court, LLC
2920 Bryant Road
Madison, Wisconsin 53713
Contact: Kevin Karamanagh

Landscape Plan
Part of Lot 3, CSM No 10769 and Lot 1, CSM No 12128, lying in the SW 1/4 of the SW 1/4 of Section 12, T08N, R10E, City of Madison, Dane County, Wisconsin

Office Map Number
16037-L

L1.0

Site Conditions	
Total Lot Area	Proposed Lot 1 = 40,067 sq ft Proposed Lot 2 = 27,856 sq ft Total Area = 67,922 sq ft
Building Area	Proposed Lot 1 = 10,288 sq ft Proposed Lot 2 = 18,415 sq ft Total Area = 28,703 sq ft
Units per Building	Proposed Lot 1 = 16 Units Proposed Lot 2 = 42 Units Total Units = 58 Units
Bedroom per Unit	Proposed Lot 1 = 32 Bedrooms Proposed Lot 2 = 30 Bedrooms Total Bedrooms = 92 Bedrooms
Lot Area per Dwelling Unit	1,462 sq ft/DU
Required Open Space	160 sf X 107 Br = 17,120 sq ft
Open Space Provided	Lot 1=12,264 sq ft + Lot 2=9,830 sq ft
Parking Required	Lot 1 = 16-2 Br/Unit X 1.75 stalls = 28 Stalls Lot 2 = 12-Efficiency X 1.00 stalls = 12 Stalls Lot 2 = 12-1 Br/Unit X 1.50 stalls = 18 Stalls Lot 2 = 18-2 Br/Unit X 1.75 stalls = 31.5 Stalls Total Stalls Required = 89.5 Stalls
Surface Stalls	Proposed Lot 1 = 15 Stalls Proposed Lot 2 = 18 Stalls
Underground Stalls	Proposed Lot 1 = 28 Stalls Proposed Lot 2 = 37 Stalls
Total Parking Stalls	98 Regular Stalls 4 Handicapped Stalls

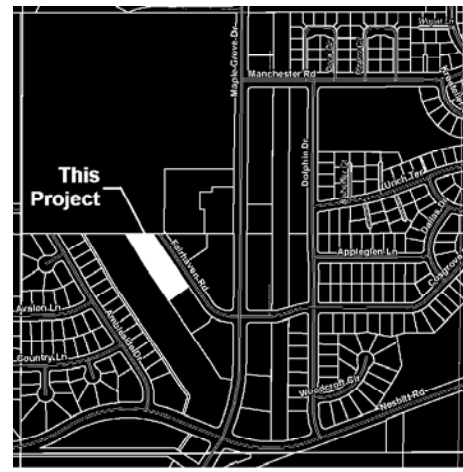

Locator
Southwest 1/4, Section 12
T06N, R12E

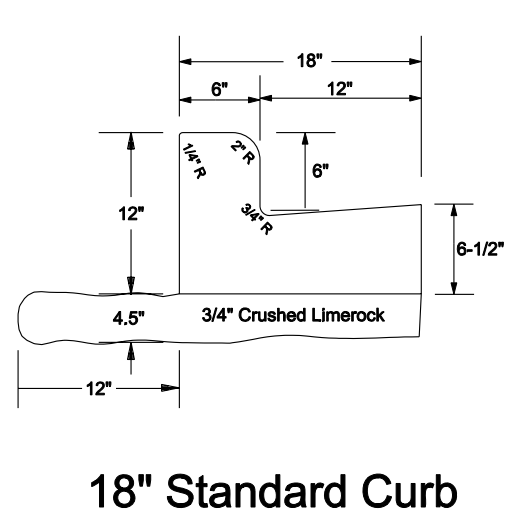
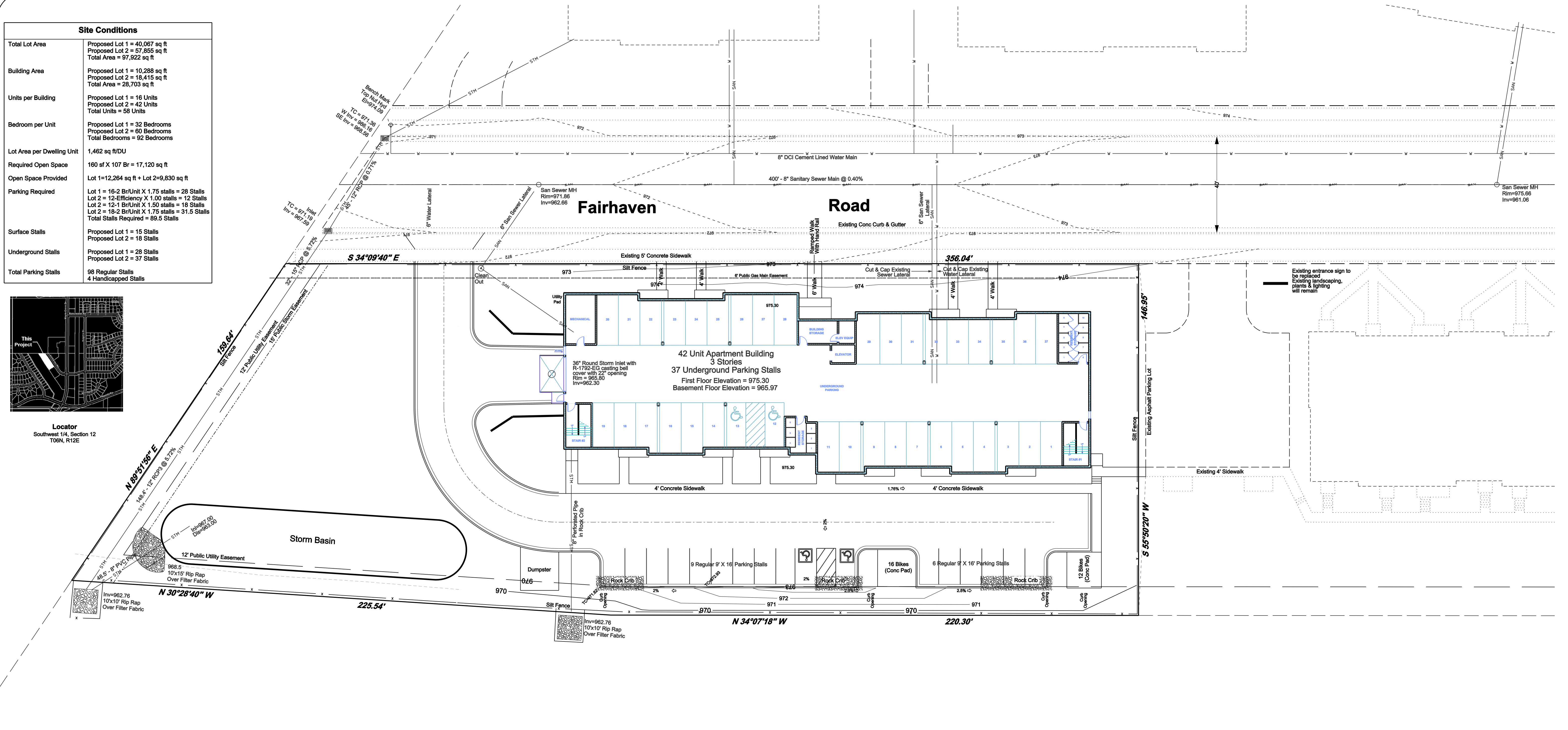

18" Standard Curb

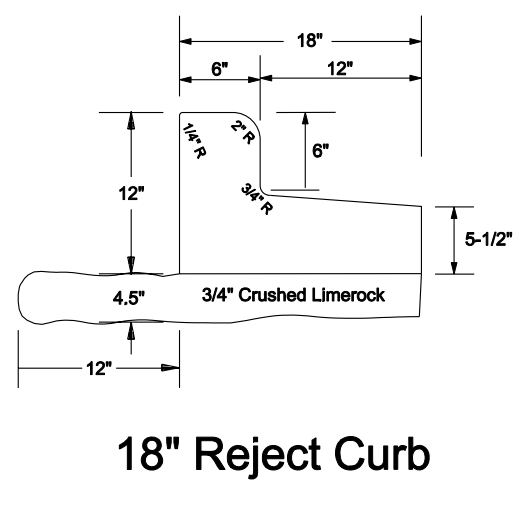

18" Reject Curb

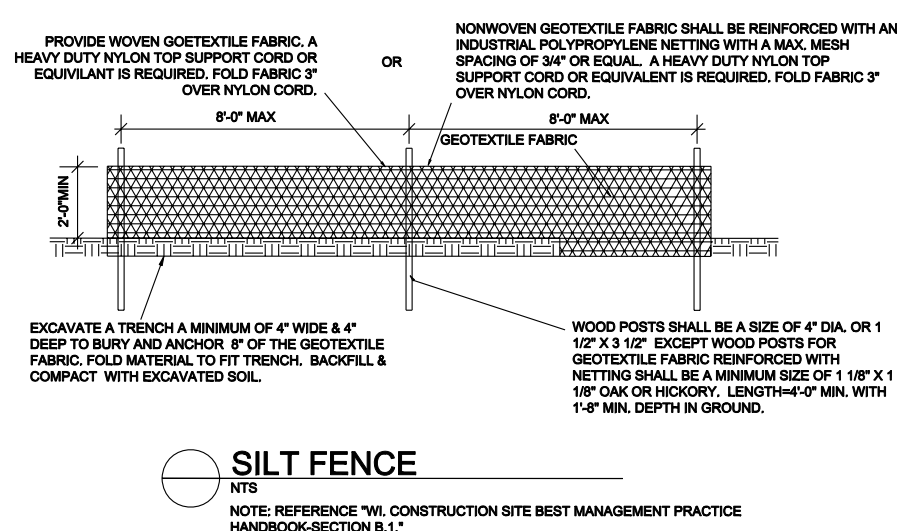

SILT FENCE

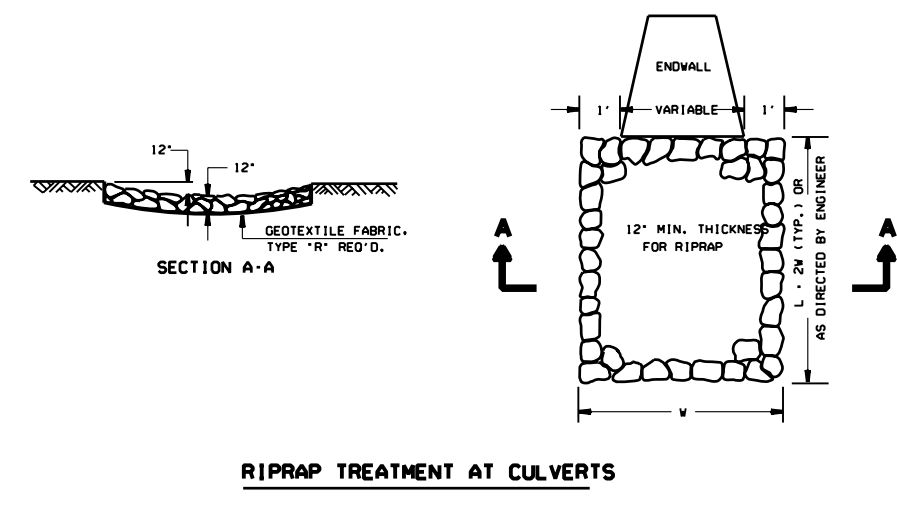

RIPRAP TREATMENT AT CULVERTS

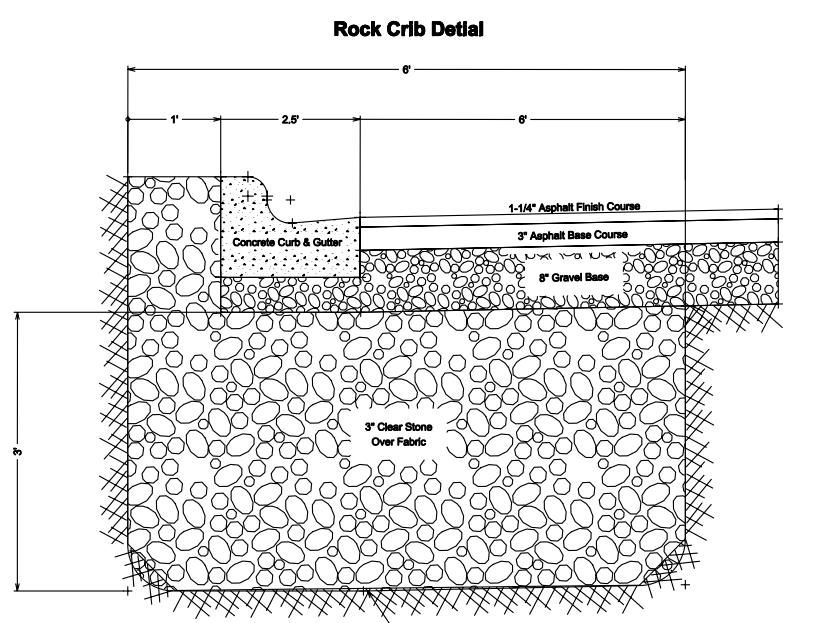

Rock Crib Detail

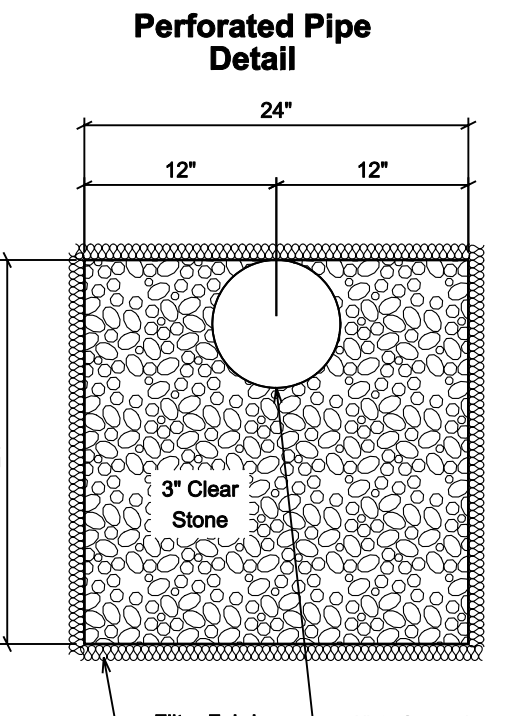

Perforated Pipe Detail

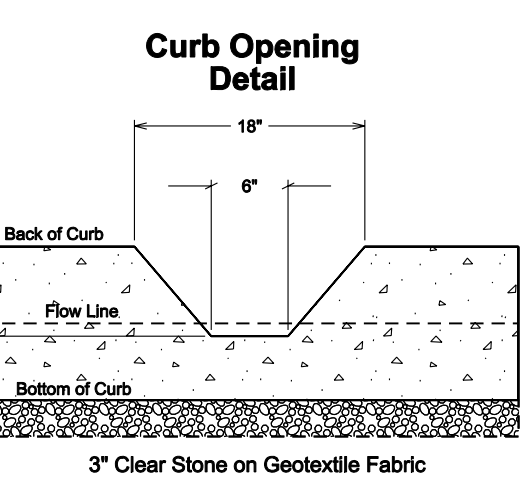

Curb Opening Detail

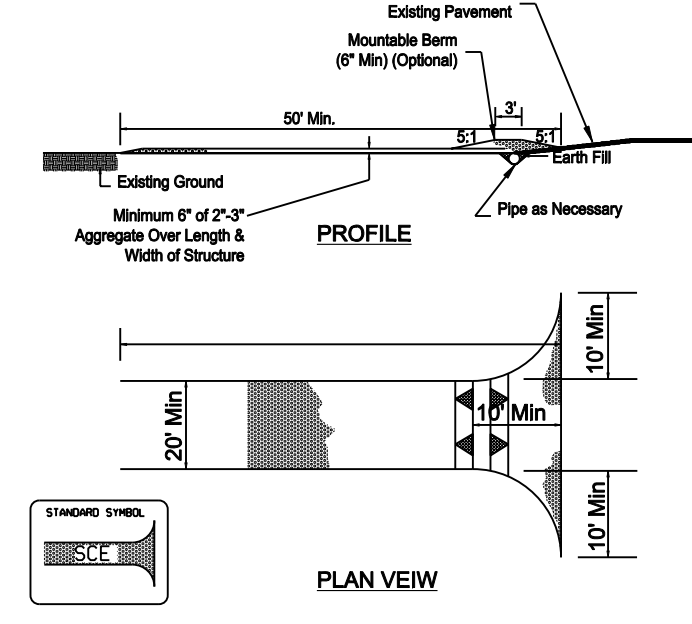

Stabilized Construction Entrance

- LENGTH - MINIMUM OF 50'
- WIDTH - 20' MINIMUM SHOULD BE FLARED AT THE EXISTING ROAD TO PROVIDE A TURNING RADIUS.
- STONE - CRUSHED AGGREGATE (2" TO 3") OR RECLAIMED OR RECYCLED CONCRETE EQUIVALENT SHALL BE PLACED AT LEAST 6" DEEP OVER THE LENGTH AND WIDTH OF ENTRANCE.
- SURFACE WATER - ALL SURFACE WATER FLOWING TO OR DIVERTED TOWARD CONSTRUCTION ENTRANCES SHALL BE PIPED THROUGH THE ENTRANCE. MAINTAINING POSITIVE DRAINAGE. PIPE INSTALLED THROUGH THE STABILIZED CONSTRUCTION ENTRANCE SHALL BE PROTECTED WITH A MOUNTABLE BERM WITH 5:1 SLOPES AND MINIMUM OF 6" OF STONE OVER THE PIPE. TO BE SIZED ACCORDING TO THE DRAINAGE. WHEN THE SIZE IS LOCATED AT A HIGH SPOT AND HAS NO DRAINAGE TO CONVEY A PIPE WILL NOT BE NECESSARY. PIPE SHOULD BE SIZED ACCORDING TO THE AMOUNT OF RUNOFF TO BE CONVEYED. A 6" MINIMUM WILL BE REQUIRED.
- LOCATION - A STABILIZED CONSTRUCTION ENTRANCE SHALL BE LOCATED AT EVERY POINT WHERE CONSTRUCTION TRAFFIC ENTERS OR LEAVES A CONSTRUCTION SITE. VEHICLES LEAVING THE SITE MUST TRAVEL OVER THE ENTIRE LENGTH OF THE STABILIZED CONSTRUCTION ENTRANCE.

Project Schedule

- 07-20-2012 Install Construction Entrance
Install silt fence around lot
Begin excavation of apartment building and parking lot
- 07-21-2012 Install gravel in parking lot area and ramp to underground parking
- 08-21-2012 Backfill along the North and West walls to a maximum of 9% grade.
- 10-01-2012 Construct apartment building
- 10-01-2012 Finish grade around building
- 10-15-2012 Seed and mulch

Notes:

- All filling, grading, and erosion control shall conform to the City of Madison ordinances.
- Erosion control devices shall be installed prior to the start of filling and grading.
- To minimize the erosion sediment, the contractor shall stage the filling and grading activities to restore the disturbed areas as final grades are achieved.
- Erosion control is the responsibility of the contractor until acceptance of this project. Erosion control measures as shown shall be the minimum precautions that will be allowed. The contractor shall be responsible for recognizing and correcting all the erosion control problems that are a result of construction activities.
- Additional erosion control measures, as requested by the City Inspector or developers engineers, shall be installed within 24 hours.
- All erosion control measures and structures serving the site must be inspected at least weekly and within 24 hours of the time 0.50 inches of rain is produced. All maintenance will follow an installed within 24 hours.
- All trucks leaving site shall have clean tires. Prior to the start of filling, the contractor shall install a tracking pad. The tracking pad shall be 50' long, 24' wide, and 1' thick. The pad shall be constructed with 3" clear stone. The construction entrance shall be maintained by the contractor in a condition in which will prevent the tracking of mud onto the public street. All material deposited on public property shall be swept up daily.

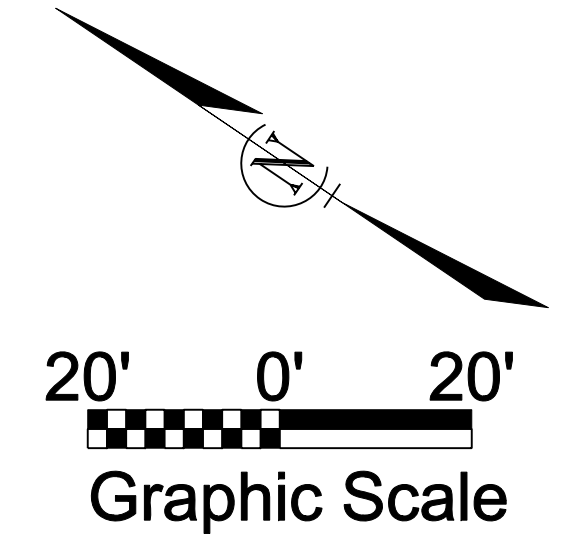

Project No:	16811
File Name:	Fairhaven.dgn
Project Name:	Fairhaven
Job Number:	001
Plot Title:	Fairhaven
Plot Tab:	Fairhaven
Director:	P:\Projects\Woodland\Woodland\Woodland\16811\16811.dwg

Royal Oak & Associates, Inc
3678 Kinsman Boulevard
Madison, WI 53704
Phone (608) 274-0500 Fax (608) 274-4530
www.royalokengineering.com

Surveyed For:
Fairhaven Court, LLC
Madison, Wisconsin 53713
Contact:
Madison, Kevin Kavanagh

PUD - GDP - SIP - Site Grading & Erosion Control Plan
Lot 3, CSM No 10769 and Lot 1, CSM No 12128, lying in the SW 1/4 of the SW 1/4 of Section 12, T06N, R10E, City of Madison, Dane County, Wisconsin

Office Map Number
16037-I
C-1.0



BACKGROUND: SW. 6084 Modest White paint

BACK: SW. 3002 Belvedere Tan stain

BORDER: 3/4" SW. 2916 Red Prairie 3" space

PINSTRIPES: 3/8" SW. 6881 Cayenne

LOGO: SW. Black with a Belvedere Tan stained background

LETTERS: SW. Black (raised), and
SW. 6084 Modest White (blasted in)

MISC: Raised Capsule painted SW. Black with letters blasted in

POSTS: SW. Belvedere Tan stain Post Trim - SW. Red Prairie

BALL TOPS: SW. Belvedere Tan stain with Black & Cayenne pinstripes



**Architectural Design
Consultants, Inc.**

Front Elevation of 16-Unit Building

Fairhaven Court - Madison, WI

This document contains confidential or proprietary information of Architectural Design Consultants, Inc. Neither this document nor the information herein is to be reproduced, distributed, used or disclosed either in whole or in part except as specifically authorized by Architectural Design Consultants, Inc.



ADCI
Architectural Design
Consultants, Inc.

Front Yard of 16-Unit Building

Fairhaven Court - Madison, WI

This document contains confidential or proprietary information of Architectural Design Consultants, Inc. Neither this document nor the information herein is to be reproduced, distributed, used or disclosed either in whole or in part except as specifically authorized by Architectural Design Consultants, Inc.



**Architectural Design
Consultants, Inc.**

Rear Elevation of 16-Unit Building

Fairhaven Court - Madison, WI

This document contains confidential or proprietary information of Architectural Design Consultants, Inc. Neither this document nor the information herein is to be reproduced, distributed, used or disclosed either in whole or in part except as specifically authorized by Architectural Design Consultants, Inc.



**Architectural Design
Consultants, Inc.**

Side Elevation of 16-Unit Building

Fairhaven Court - Madison, WI

This document contains confidential or proprietary information of Architectural Design Consultants, Inc. Neither this document nor the information herein is to be reproduced, distributed, used or disclosed either in whole or in part except as specifically authorized by Architectural Design Consultants, Inc.



**Architectural Design
Consultants, Inc.**

Development to the East

Fairhaven Court - Madison, WI

This document contains confidential or proprietary information of Architectural Design Consultants, Inc. Neither this document nor the information herein is to be reproduced, distributed, used or disclosed either in whole or in part except as specifically authorized by Architectural Design Consultants, Inc.



**Architectural Design
Consultants, Inc.**

Undeveloped Site

Fairhaven Court - Madison, WI

This document contains confidential or proprietary information of Architectural Design Consultants, Inc. Neither this document nor the information herein is to be reproduced, distributed, used or disclosed either in whole or in part except as specifically authorized by Architectural Design Consultants, Inc.



**Architectural Design
Consultants, Inc.**

Development to the North

Fairhaven Court - Madison, WI

This document contains confidential or proprietary information of Architectural Design Consultants, Inc. Neither this document nor the information herein is to be reproduced, distributed, used or disclosed either in whole or in part except as specifically authorized by Architectural Design Consultants, Inc.



**Architectural Design
Consultants, Inc.**

Development to the North

Fairhaven Court - Madison, WI

This document contains confidential or proprietary information of Architectural Design Consultants, Inc. Neither this document nor the information herein is to be reproduced, distributed, used or disclosed either in whole or in part except as specifically authorized by Architectural Design Consultants, Inc.



**Architectural Design
Consultants, Inc.**

Development to the West

Fairhaven Court - Madison, WI

This document contains confidential or proprietary information of Architectural Design Consultants, Inc. Neither this document nor the information herein is to be reproduced, distributed, used or disclosed either in whole or in part except as specifically authorized by Architectural Design Consultants, Inc.



**Architectural Design
Consultants, Inc.**

Rear Yard of 16-Unit Building

Fairhaven Court - Madison, WI

This document contains confidential or proprietary information of Architectural Design Consultants, Inc. Neither this document nor the information herein is to be reproduced, distributed, used or disclosed either in whole or in part except as specifically authorized by Architectural Design Consultants, Inc.



**Architectural Design
Consultants, Inc.**

Development to the South

Fairhaven Court - Madison, WI

This document contains confidential or proprietary information of Architectural Design Consultants, Inc. Neither this document nor the information herein is to be reproduced, distributed, used or disclosed either in whole or in part except as specifically authorized by Architectural Design Consultants, Inc.



**Architectural Design
Consultants, Inc.**

Development to the South

Fairhaven Court - Madison, WI

This document contains confidential or proprietary information of Architectural Design Consultants, Inc. Neither this document nor the information herein is to be reproduced, distributed, used or disclosed either in whole or in part except as specifically authorized by Architectural Design Consultants, Inc.

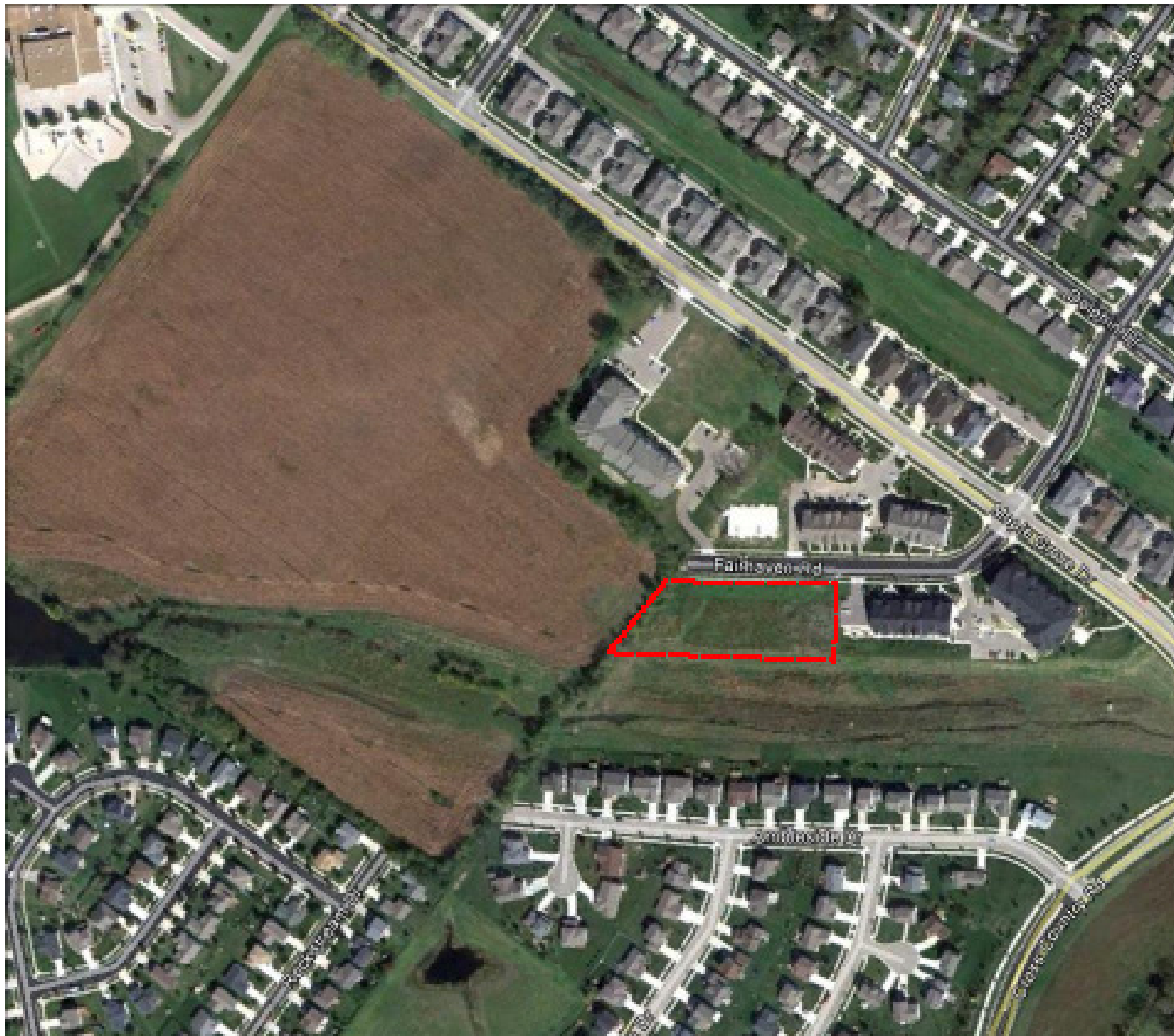

**Architectural Design
Consultants, Inc.**

Location Map



Fairhaven Court - Madison, WI

LETTER OF INTENT
TO THE PLAN COMMISSION AND
CITY COUNCIL OF THE CITY OF MADISON

PLANNED UNIT DEVELOPMENT - SPECIFIC IMPLEMENTATION PLAN
PUD (SIP)

Residential Development
Lot 3, Certified Survey Map No. 10769, now known as Units
6717-1 through 6717-16, inclusive, and Units 6725-1 through 6725-16,
inclusive, Twisted Tree Condominium and Lot 1, Certified Survey Map No. 12128.
6717, 6725 and 6733 Fairhaven Road
In the City of Madison, Dane County, Wisconsin
To be known as Fairhaven Court

Application Submittal Date:

May 9, 2012

Project Name:

Fairhaven Court

Owner:

Fairhaven Court, LLC
2920 Bryant Road
Madison, Wisconsin 53713
Contact: Kevin Kavanaugh
(608) 271-8514
kevin@krsrestequip.com

Designer:

Russell A. Eilers, AIA
Architectural Design Consultants, Inc.
30 Wisconsin Dells Parkway
P.O. Box 580
Lake Delton, WI 53940
(608) 254-6181
r.eilers@adcidesign.com

Engineer:

Eric W. Sandsnes, PLS
Royal Oak & Associates, Inc.
3678 Kinsman Boulevard
Madison, WI 53704-2509
(608) 274-0500 Ext. 13
esandsnes@royaloakengineering.com

Landscape Architect:

Watts Landscaping Service
350 Pioneer Avenue
Verona, WI 53593
608-833-3535

Legal:

Project:

42-unit apartment building to be located on a portion of Lot 3 Certified Survey Map No. 10769, now known as 6725-1 through 6725-16, inclusive, Twisted Tree Condominium (6725 Fairhaven Road) and Lot 1 of Certified Survey Map No. 12128 (6733 Fairhaven Road); and an existing 16-unit building located on a portion of Lot 3 Certified Survey Map No. 10769, now known as Units 6717-1 through 6717-16, inclusive, Twisted Tree Condominium, (6717 Fairhaven Road) in the City of Madison, Dane County, Wisconsin.

The proposed development, part of Madison's very popular Cross Country neighborhood, currently consists of 1 townhouse style building with 16 condominium units (located on Lot 3 CSM 10769, 6717 Fairhaven Road), and a 42-unit multi-family apartment building all totaling 93,609 square feet of dwelling unit improvements, including underground parking. The condominium will be dissolved and the units will become multi-family rental units.

This development has been designed to provide a maximum amount of functional and usable open space proximate to all dwelling units. Block retaining walls will be used to accommodate grade changes and flat open lawn areas will be adjacent to all areas of the building. Asphalt paving has been minimized and proposed landscaping does not hinder the use of the lawn areas.

Front porches are included with the dwelling units for all ground units, and balconies are provided for upper units. A variety of landscaping will be used to act as screening or for general separation of those units.

Uses/Family Definition:

The uses of Lots 1 and 3 are as follows:

CSM Lot No	Permitted Use	Lot Area	Permitted Dwelling Units	Bedrooms
Lot 1 CSM 12128 and a portion of Lot 3 CSM 10769	Multi-Family Building	57,856 s.f.	42	60
Lot 3 CSM 10769	Townhouse Units	40,067 s.f.	16	32
		<u>97,923 s.f.</u>	<u>58</u>	<u>92</u>

The improvements to Lot 1 CSM 12128 and a portion of Lot 3 CSM 10769 (6725 and 6733 Fairhaven Road) shall consist of one 42-unit apartment building. There exists on a portion of Lot 3 CSM 10769 one townhouse style building with 16 condominium units, the condominium will be dissolved. This is to be a multi-family development owned and operated as a residential apartment development. The units and the common areas of the residential apartment development shall be used for residential purposes only, as per the R4 zoning district. The family definition shall coincide with the definition given in Madison General Ordinance 28.03 for the R1 zoning district.

Accessory uses shall include but not be limited to: a. accessory uses directly associated with those permitted uses including parking for tenants and guests, and b. temporary building for storage of building materials and equipment for construction purposes when on same lot as a principle use for a period not to exceed the duration of such construction.

Timetable for Construction:

Building construction is anticipated to begin immediately following plan approval. Ultimate completion is expected in approximately nine months.

Total area of Lots 1 and 3:

Lot 1 CSM 12128-57,856 sq. ft.; Lot 3 CSM 10769-40,067 sq. ft.; total 97,923 sq. ft.

Lot Area Requirements:

Per PUD (SIP) total area as defined above is

Lot 1 CSM 12128-57,856 sq. ft.; Lot 3 CSM 10769-40,067 sq. ft.; total 97,923 sq. ft.

Dwelling Units:

Dwelling units proposed: 42 new apartment units (6725 and 6733 Fairhaven Road) plus existing 16 units (6717 Fairhaven Road).

Lot Area Per Dwelling Unit:

1,688 sq. ft./u;

Usable Open Space/Requirements:

Area Required 160 s.f./bedroom: 14,720 sq. ft.

Useable Open Space Provided:

Lot 1= 12,264 s.f. + Lot 2= 9,830 s.f.

Snow and Trash Storage and Removal, Maintenance:

Snow and trash storage and removal will be done by private contractor. All on-site maintenance equipment will be stored within the underground parking garages.

Economic/Socioeconomic Impact:

The development is readily accessible to a variety of employment centers, retail services, daycare centers, and recreation areas and is in the vicinity of multi-family single-family development which dominates the area.

Rents for the apartment units of the existing building will range from \$[] for [] bedrooms to \$[] for [] bedrooms. Rents for the apartment units of the new building will range from \$[] for [] bedrooms to \$[] for [] bedrooms.

Sincerely,

Fairhaven Court, LLC

ZONING TEXT

PLANNED UNIT DEVELOPMENT - SPECIFIC IMPLEMENTATION PLAN
PUD (SIP)
May 9, 2012

Residential Development

Lot 3, Certified Survey Map No. 10769, now known as Units
6717-1 through 6717-16, inclusive, and Units 6725-1 through 6725-16,
inclusive, Twisted Tree Condominium and Lot 1, Certified Survey Map No. 12128.
6717, 6725 and 6733 Fairhaven Road
In the City of Madison, Dane County, Wisconsin
To be known as Fairhaven Court

Statement of Purpose:

This Planned Unit Development Specific Implementation Plan PUD (SIP) provides for a new 56,768 gross square foot, 42-unit residential development with underground parking located on a portion of Lot 3 Certified Survey Map No. 10769, now known as 6725-1 through 6725-16, inclusive, Twisted Tree Condominium (6725 Fairhaven Road) and Lot 1 of Certified Survey Map No. 12128 (6733 Fairhaven Road); and an existing 16-unit building located on a portion of Lot 3 Certified Survey Map No. 10769, now known as Units 6717-1 through 6717-16, inclusive, Twisted Tree Condominium, (6717 Fairhaven Road) in the City of Madison, Dane County, Wisconsin.

The proposed development, part of Madison's very popular Cross Country neighborhood, currently consists of 1 townhouse style building with 16 condominium units (located on Lot 3 CSM 10769, 6717 Fairhaven Road), and a 42-unit multi-family apartment building all totaling 93,609 square feet of dwelling unit improvements, including underground parking. The condominium will be dissolved and the units will become multi-family rental units.

This development has been designed to provide a maximum amount of functional and usable open space proximate to all units. Block retaining walls will be used to accommodate

grade changes and flat open lawn areas will be adjacent to all areas of the building. Asphalt paving has been minimized and proposed landscaping does not hinder the use of the lawn areas.

Front porches are included with the dwelling units for all ground units, and balconies are provided for upper units. A variety of landscaping will be used to act as screening or for general separation of those units.

Building Descriptions:

This development will consist of 58 dwelling units. The dwelling units will offer a mix of interiors and amenities with a total of approximately 92 bedrooms. The apartment buildings will offer units ranging from roughly 580-1,730 s.f.

CSM Lot No	Permitted Use	Lot Area	Permitted Dwelling Units	Bedrooms
Lot 1 CSM 12128 and a portion of Lot 3 CSM 10769	Multi-Family Building	57,856 s.f.	42	60
Lot 3 CSM 10769	Townhouse Units	40,067 s.f.	16	32
		<u>97,923 s.f.</u>	<u>58</u>	<u>92</u>

The improvements to Lot 1 CSM 12128 and a portion of Lot 3 CSM 10769 (6725 and 6733 Fairhaven Road) shall consist of one 42-unit apartment building. There exists on a portion of Lot 3 CSM 10769 one townhouse style building with 16 condominium units, the condominium will be dissolved. This is to be a multi-family development owned and operated as a residential apartment development. The units and the common areas of the residential apartment development shall be used for residential purposes only, as per the R4 zoning district. The family definition shall coincide with the definition given in Madison General Ordinance 28.03 for the R1 zoning district.

Accessory uses shall include but not be limited to: a. accessory uses directly associated with those permitted uses including parking for tenants and guests, and b. temporary building for storage of building materials and equipment for construction purposes when on same lot as a principle use for a period not to exceed the duration of such construction.

Yard Requirements:

Minimum Yard Requirements:

- Front Yard: 10 ft.
- Side Yard: 5 ft.
- Rear Yard: 30 ft.

Total area of Lots 1 and 3:

Lot 1 CSM 12128- 57,856 sq. ft.; Lot 3 CSM 10769-40,067 sq. ft.; total 97,923 sq. ft.

Lot Area Requirements

Per PUD (SIP) total area as defined above is Lot 1 CSM 12128-57,856 sq. ft.; Lot 3 CSM 10769-40,067 sq. ft.; total 97,923 sq. ft.

Dwelling Units

Dwelling units proposed: 42 new apartment units (6725 and 6733 Fairhaven Road) plus existing 16 units (6717 Fairhaven Road)

Lot Area Per Dwelling Unit

1,688 sq. ft./u;

Usable Open Space/Requirements:

Area Required 160 s.f./bedroom: 14,720 sq. ft.

Usable Open Space Provided:

Lot 1= 12,264 s.f. + Lot 2= 9,830 s.f.

Height Requirements:

Maximum Building Height is 3 stories or 40 ft.

Proposed Building Height is 3 stories with average height of 36 ft.

Landscaping:

Landscaped areas will be provided as shown on approved plans. Upon commencement of building construction, a local provider will be responsible for the installation of all landscape materials.

Accessory Off-Street Parking:

Min. Parking Stalls Required: 89.5 spaces

Parking Stalls Provided: 102 spaces above ground; 65 spaces underground.

Bicycle Requirements:

Spaces required: 58
Spaces provided: [civil]

Site Lighting:

Lighting will be provided as shown on approved plans.

Signage:

Signage will be as shown on approved plans--
Max. Allowable Signage: 20 sq. ft. Proposed Signage: 17 sq. ft.

All signage shall be per the approved PUD (SIP).

Snow and Trash Storage and Removal, Maintenance:

Snow and trash storage and removal will be done by private contractor. All on-site maintenance equipment will be stored within the underground parking garages.

Alterations and Revisions:

No alteration or revision of this Planned Unit Development shall be permitted unless approved by the City Plan Commission, However, the Zoning Administrator may issue permits for minor alterations or additions that are approved by the Director of Planning and Development and the Alderperson of the district and are compatible with the concept approved by the City Plan Commission.