



May 29, 2019

Heather Stouder
City of Madison
Department of Planning & Community & Economic Development
115 Martin Luther King Jr. Blvd.
Suite LL 100, Madison Municipal Building
Madison, WI 53703

**RE: LETTER OF INTENT - EAST END APARTMENTS
NEW MIXED USE DEVELOPMENT
MADISON, WI 53703**

Dear Ms. Stouder,

The following is submitted together with the subdivision application, associated plans and documents for review by City Staff, the Landmarks Commission, the Urban Design Commission, the Plan Commission and the City Council for consideration of approval.

PROJECT TEAM:

Developer: McGrath Property Group, 730 Williamson St. Suite 150, Madison, WI 53703
Architect: CaS4 Architecture, 4414 Regent Street, Suite 102, Madison, WI 53705
Landscape Arch/Civil Engineer: Vierbicher, 999 Fourier Dr. Suite 201, Madison, WI 53717
Surveyor: Isthmus Surveying, 450 N. Baldwin St Madison, WI 53703

PROJECT OVERVIEW:

The Developer is under contract to purchase an assembly of properties from the current land owner. The proposed project will sit on a portion of that assembly, including 510-518 E. Wilson Street, a portion of 506 E. Wilson (extending out to S Franklin St), a portion of 148 S. Blair and 134-140 S. Blair Street. The footprint for the project is currently predominantly surface parking (see Exhibit A for Legal Description of the Site).

Also included in the purchase but excluded from this development proposal are the four homes located at 110 - 120 S. Blair and the building located at 506-508 E. Wilson (commonly known as the Come Back In). The Developer intends to restore the 506-508 building on a separate track and currently has no plans for the 4 homes on S. Blair St.

The site is 60,655 SF in area (1.39 Acres) and sits in two different Historic districts. The properties fronting E. Wilson Street are in a National Historic District and all of the parcels to the north of them are in the Local First Settlement Historic District. The project site will be part of a new CSM to consolidate the lots that it sits on. The project is located in the 6th Aldermanic District, First Settlement Neighborhood. It is currently zoned Planned Development (PD), WP-17 with the parking lot area having the additional designation of HIS-FS.

Demolition of 510 thru 518 E. Wilson will be necessary to complete the project. 518 E. Wilson is listed as a "Contributing" building to the National Historic district but it is the opinion of the Developer that this building is beyond the point of feasibly being able to restore. Areas of the existing structure are pulling apart from each other along the exterior walls, portions of the foundation are collapsing in on themselves and have led to areas of floor framing falling in within the current structure. Additionally, removal of this building helps to honor and improve the character and viability of the adjacent Hotel Ruby Marie property at 524 E. Wilson St - which is also listed as "Contributing" to the National Historic District.

Following demolition and excavation of the site, new construction consisting of a 5-story, mixed-use rental building containing: 153 residential units, 11,000 SF of commercial space and 220 parking stalls. The proposed building has frontages on E. Wilson and S. Blair Streets.

All parking serving the property is accessed from S. Blair St. where there is a separate entrance for ingress and egress into the parking. There is also a 2-lane turn-around area in between the ingress/egress for postal/Fed-Ex/Ups deliveries, and taxi/Uber pick ups and drop offs. Additionally there is a separate loading zone accessed off of S. Franklin St to serve the building and for tenant move-ins/move-outs that utilize a larger moving truck. Refuse/Recycling collection will occur at this same location.

The Developer is also required to provide up to 30 parking stalls in the project for users of the Hotel Ruby Marie. To facilitate their access to the parking, a small parking garage entry has been added which will allow them to drop off luggage behind the hotel and then enter the garage without going back onto S. Blair St.

A consultant has been retained to prepare a Traffic Study for the project. This report will be submitted at a later date.

Specific building areas and other pertinent information is provided on the attached plans. No public subsidy is being requested for this project.

NEIGHBORHOOD INPUT:

The project is located in the First Settlement Neighborhood (FS). City Staff, the Alder and FS leaders were notified in writing of this project on February 25, 2019. A public notice neighborhood meeting was held on April 25, 2019 and a second public notice meeting was held on May 16, 2019. The developer has also met several times with City Staff and the neighborhood "Steering Committee" that was formed for the project. The development team has shared information with this committee and will continue to meet on an as-needed basis as the final details of the project are worked thru.

ZONING:

The proposed site is currently zoned Planned Development (PD) - but it is the Developer's understanding that this zoning has expired. The proposed project is predominantly, if not entirely, consistent with Downtown Core (DC) zoning. At the recommendation of City Staff we are requesting that the site be rezoned as PD using the Urban Mixed-Use zoning category as its basis.

The proposed project is generally consistent with the First Settlement neighborhood plan and other city plans. The site is specifically called out as an under-utilized site and is recommended for predominately residential mixed use redevelopment. The City of Madison Zoning Code allows for buildings up to 6 stories tall on the site and we are staying 1-level below that maximum.

ARCHITECTURAL/LANDMARKS DIALOG:

The current zoning and downtown height map, along with recommendations in the Downtown Plan, the updated Comprehensive Plan, and the First Settlement Neighborhood Plan (1995) all point to this particular site as being underutilized and a prime candidate for a more intensive development. The Downtown Plan points to this block (Block 115) as underutilized and a focus for more intensive redevelopment. The Comprehensive Plan defines these sites as ones for generally larger multifamily buildings or multifamily complexes. Within the First Settlement Neighborhood Plan it calls for higher density residential developments on arterial streets, institutional edges, and Lake Monona frontage. This site is identified as R7 within the neighborhood plan and again calls for higher density and higher rise development due to its location along major transportation corridors and/or valuable lakefront sites such as the E. Wilson Street frontage.

The proposed development is comprised of 153 residential units, 11,000 sf of new commercial space along South Blair Street and E. Wilson Street, and 220 internal structured parking stalls. The building's grade level commercial space and residential lobby along both E. Wilson Street and South Blair Street are a taller single story to allow for better commercial spaces that will also shield the internal structured parking located at the center of the site. Above the grade level along E. Wilson Street and South Blair Street are four levels of residential housing. The building scale and its location fit within the boundaries of the downtown height map and keep the taller mass of the development along the edges of the First Settlement Neighborhood and in relation with the taller neighboring structures of the Cardinal Hotel, South Franklin Street Condominiums, MG&E buildings, Settlement Place, The Ruby Marie Hotel, and 320 E. Wilson Street apartments. This is a key component to both the Downtown Plan and First Settlement Neighborhood Plan recommendations for potential development of this site. Within the depth of the site a two level portion of residential apartments steps down to the scale of the Germania condominiums; refer to attached sections within the submittal that describe this situation further. Along E. Wilson Street the Come Back In remains as an independent structure within the development and will be renovated on a separate track of approval and permitting.

The focus of this project has been developing an architectural language that looks to the existing buildings within the neighborhood and surrounding buildings within a 200 foot radius of the perimeter of the site and taking cues from those structures to create a development that relates to the neighboring structures without mimicking them. The following portion of the design narrative looks to address the City of Madison historic preservation standards for the First Settlement Historic District. These standards along with a design concept that looks to relate to existing context through scale, proportion, and rhythm is the driving force of the overall design of the project.

The height of the proposed building is equal to or less than the height of buildings within a 200 foot radius of the site; those buildings include the Cardinal Hotel and MG&E buildings. The corner elements located on 115 South Franklin Condominiums are approximately equal to the roof elevation of the proposed building; some are a few feet taller and some are a few feet shorter. The overall mass of the building is broken down along both East Wilson Street and South Blair to relate the buildings horizontal scale at the street edge to that found within 200 feet of the site. Along South Blair Street the façade is broken down into two main “buildings” that relate in length to the street scale of Settlement Place and the MG&E buildings across South Blair Street. The vertical scale looks to relate to the datum set by Settlement Place and Hotel Ruby Marie. At the datum the masonry plans terminate to reveal a rhythm of 4” exposure cement board lap sided bays to create a simple rhythm along the South Blair Street elevation that translates down through the inset balcony conditions. As you walk along the building the columns of the covered main entry and parking access component is within 18” of the sidewalk; the building then steps back 10’-6” to the portion of the building that is rendered as the “break” between the two main “buildings” before stepping back out with the commercial storefront that is held back 4’-6” from the back of the sidewalk. The introduction of canopies to provide shelter at the storefronts also creates another texture and rhythm that is in line with the scale of other storefronts found at the Hotel Ruby Marie. The storefront within the masonry openings at grade level is setback 16-24” to provide a sense of a thick masonry wall. This articulation within the façade helps to provide variety and scale along the building face that is similar to the buildings located along both sides of South Blair Street and East Wilson Street. The commercial storefronts along both East Wilson and South Blair are of a scale similar to that found on the Hotel Ruby Marie as well as the Cardinal Hotel and other storefronts of buildings of that period. The pedestrian experience along East Wilson Street is one that looks to maintain the street level experience that is created by both the Ruby Marie Hotel, the Come Back In, and the Cardinal Hotel where the scale and rhythm of the storefront is maintained on the building to complement that which is in place on both adjacent existing structures. The articulation and detailing of the masonry along East Wilson Street is done in a fashion that subtly relates to that which is found on both the Come Back In and the Hotel Ruby Marie. Soldier course headers and header course jamb details that are found on both of these structures provide details at the openings along East Wilson Street. This detailing combined with the proportion and rhythm of the openings is consistent with the two adjacent pre-1930 buildings and also those found on the Cardinal Hotel and the early MG&E buildings on South Blair Street. The beauty of the existing buildings adjacent to the proposed building on East Wilson Street is that they are detailed and arranged to create a subtle rhythm within the elevation. The elevation of the new structure along East Wilson Street uses a similar concept of subtle cues within the overall masonry elevation to breakdown the façade both vertically and horizontally. The horizontal layout of the elevation provides subtle changes in the layout of the openings at grade to define commercial storefronts from residential building entry with the incorporation of a soft

arched entry in combination with stepping out the face of the wall 4". The vertical proportion and scale is broken down with a cast stone course that runs at the elevation of the Come Back In while the continuous punched windows of the first two floors above the commercial space are to relate back to the scale and proportion of the Ruby Marie Hotel. As the building moves above the fourth floor the masonry finishes with a (3) soldier course and cast stone cap. The residential units step back 9 feet from the masonry face to allow the upper level to be rendered with a flat seam metal panel in a scale of 14"x38" horizontally. This metal panel installation is used within the portion of the building along East Wilson and a few highlights within the elevation along South Blair Street. This color of metal is found on the MG&E buildings within 200 feet of the site.

As we move around the building and begin to engage the residential component of the neighborhood the building steps down to two levels of housing immediately adjacent to the residential neighborhood fronting on South Franklin Street. With the transition into the residential neighborhood the material palette becomes that which is similar to a majority of the homes and townhouse condominiums that front South Franklin Street. The proposed material composition at these elevations is a combination of modular masonry units in a running bond coursing along with two colors of smooth faced 4" cement board lap siding (grey and darker brown); these materials are components suggested within the City of Madison historic preservation standards for the First Settlement Historic District. Again the proportion and scale of the window openings is that which is found within most of the neighboring residential community. A series of double hung window conditions mixed in with larger "Chicago Style" windows comprised of a double hung window on each side of a fixed pane window create a distinction between living spaces and bedrooms. The elevation of the building that runs parallel to the Germania Condominiums is set up to provide (8) townhouse type units within the new building. This relationship and scale of a two story unit works directly with the scale and rhythm of the existing town house typology of the Germania Condominiums. Special attention has been put into the landscaping and setbacks of the units from the face of the building to provide a sense of privacy for all residence within both buildings; refer to the section within the packet of information for further graphic information.

Through the use of similar materials, proportion, and rhythm this project takes the cues and qualities of the buildings found within 200 feet of the site as its design direction to articulate an appropriately scaled design of its time, and for its context and location within the City of Madison, that is sympathetic to its context without mimicking it.

REFUSE & RECYCLING:

Garbage and recycling from the property will be collected by a private service. Roll-out containers serving the residential and commercial spaces will be located in an enclosed room on the grade level portion of the parking structure. Access to the collection room is from S. Franklin St. Collection vehicles will pull into the driveway and temporarily park while the roll out containers are loaded for collection.

AFFORDABLE HOUSING:

We are working with WHEDA to finance the project. If successful we will be renting 20% of the units to Tenant's who do not earn more than 80% of Dane County Medium Income.

ECONOMIC IMPACTS:

The construction of the project will have a positive impact on trade labor as it will utilize approximately 150-200 craftsmen from several local and regional businesses over an 18 month period. Additionally, businesses involved with manufacturing materials incorporated into the project will see an ancillary benefit from the development as well.

The current assessed value of the properties that the project sits on is \$1,992,400 - we expect the new project to generate an property tax increment of nearly **20X** once complete.

GREEN FEATURES:

We will be working with Focus on Energy to incorporate as many energy efficient features as possible. We anticipate using energy efficient light fixtures, energy star appliances, high efficiency forced air furnaces and air conditioners, low flow plumbing fixtures, and Low-E glass on the windows. Common mechanicals will also be high efficiency.

We will also explore photovoltaic solar panels on the roof - and hopefully will be able to install them if we can receive subsidies to help off set the significant initial cost of the solar installation.

We will install a minimum of two electric car charging stations in the parking level and will have the ability to add more in the future as needed.

PROJECT SCHEDULE:

5/6/19:	Landmarks - Informational Meeting
5/8/19:	UDC - Informational Meeting
5/29/19:	Formal Application
6/24/19:	Landmarks Commission Meeting
7/17/19:	UDC Initial/Final Approval Meeting
7/29/19:	Plan Commission Meeting
8/6/19:	City Council Meeting
10/1/19:	Start Construction
4/1/21:	Occupancy

Please feel free to contact me if additional information is needed.

Sincerely,

A handwritten signature in black ink that reads "Lance T. McGrath". The signature is written in a cursive, slightly slanted style.

Lance T. McGrath
Owner - McGrath Property Group, LLC

Attachments:

- Exhibit A: Legal Description
- Exhibit B: Zoning Text
- Exhibit C: Photographs of Buildings to be Demolished
- Exhibit D: Management Plan
- Exhibit E: Tandem Parking Plan

EXHIBIT A

LEGAL DESCRIPTION

EXHIBIT A

Legal Description

A parcel of land being parts of Lots Five (5), Six (6), Seven (7) Eight (8), Nine (9), Ten (10) and Eleven (11), and all of Lots Twelve (12), Thirteen (13) and Fourteen (14) Block One Hundred and Fifteen (115), Pritchette Original Plat of Madison, located in Government Lot 4, or the SE 1/4 of the SW 1/4 of Fractional Section 13, T7N, R9E, in the City of Madison, Dane County, Wisconsin, more particularly described as follows:

Commencing at the Computed Southwest 1/4 Corner of said Fractional Section 13, T7N, R9E, thence S 88° 53'32" E, along the South line of said Fractional Southwest 1/4 of Section 13, 507.11 feet to a point being, S 01° 06'28" W, 0.38' from the Meander Corner East of the said Southwest corner of Fractional Section 13; Thence continue S 88° 53'32" E, along said South line, 1388.78 feet to the Meander Corner West of the South 1/4 Corner of said Fractional Section 13; thence N 02° 14'09" E, along a random line, 524.10 feet to a point on the Southwesterly platted boundary line of said Lot 8, Block 115, said line also being the northeasterly right-of-way line of South Franklin Street, and the point of beginning of this description; thence N 43° 48'19"W, along said southwesterly line of said Lot 8, Block 115 and right-of-way line of South Franklin Street, 29.51 feet; thence N 46° 11'41"E, 58.15 feet; thence N 41° 39'09"W, 8.08 feet to a point of curvature; thence 10.28 feet along the arc of a 7.20 foot radius curve to the right, a chord bearing of N 03° 07'58"E, 9.43' and a delta angle of 81° 46'19"; thence N 46° 11'41"E, 12.34 feet; thence N 43° 48'19"W, 203.99 feet; thence N 46° 11'41"E, along the northwesterly platted boundary line of said Lot 5, Block 115, 55.39 feet; thence N 45° 44'04"E, along the northwesterly platted boundary line of said Lot 14, Block 115, 132.27 feet; thence S 43° 48'02"E, along the northeasterly platted boundary line of said Lots 14, 13, 12 and 11, Block 115, said line also being the southwesterly right-of-way line of South Blair Street, 231.68 feet; thence S 46° 04'44"W, 67.00 feet; thence S 43° 48'02"E, 99.25 feet; thence S 46° 11'41"W, along the southeasterly platted boundary line of Lots 10 and 9, Block 115, said line also being the northwesterly right-of-way line of East Wilson Street, 154.21 feet;

thence N 43° 48'19"W, 82.00 feet;

thence S 46° 11'41"W, 44.10 feet to the point of beginning,

This description contains an area of 60,655 Square Feet or 1.39 Acres.

EXHIBIT B

ZONING TEXT

ZONING TEXT:

The East End Apartments

Madison, WI 53703

May 29, 2019

Legal Description: See Attached Exhibit A

A. *Statement of Purpose:*

This Planned Development - Specific Implementation Plan zoning district is established to allow for the construction of a mixed-use development with 153 apartments, 11,000 square feet of commercial space and three levels of parking.

B. *Permitted Uses:*

Uses that are permitted or conditional in the UMX (Urban Mixed-Use) District.

C. *Lot Area:*

60,655 square feet as shown on the approved specific implementation plans.

D. *Height Regulations:*

As shown on the approved specific implementation plans.

E. *Yard Regulations:*

As shown on the approved specific implementation plans.

F. *Landscaping:*

As shown on the approved specific implementation plans.

G. *Usable Open Space Requirements:*

As shown on the approved specific implementation plans.

H. *Parking and Loading:*

Off-street auto, bike parking and loading shall be provided as shown on the approved plans.

I. *Lighting:*

As shown on approved specific implementation plans.

J. *Family Definition:*

The family definition shall coincide with the definition given in M.G.O. 28.211 for the UMX zoning district.

K. *Signage:*

Signage for the building will be the maximum allowed per UMX zoning district, and as approved by the Urban Design Commission or its Secretary, and the Zoning Administrator.

L. *Alterations and Revisions:*

No alteration or revision of this Planned Development shall be permitted unless approved by the City Planning Commission, however, the Zoning Administrator may issue permits for minor alterations or additions which are approved by the Director Of the Department of Planning and Community and Economic Development and the alderperson of the district, and are compatible with the concept approved by the Common Council.

EXHIBIT C

PHOTOGRAPHS OF BUILDINGS TO BE DEMOLISHED

The East End

E. Wilson & Blair

Proposed for Demolition

510 - 518 E Wilson

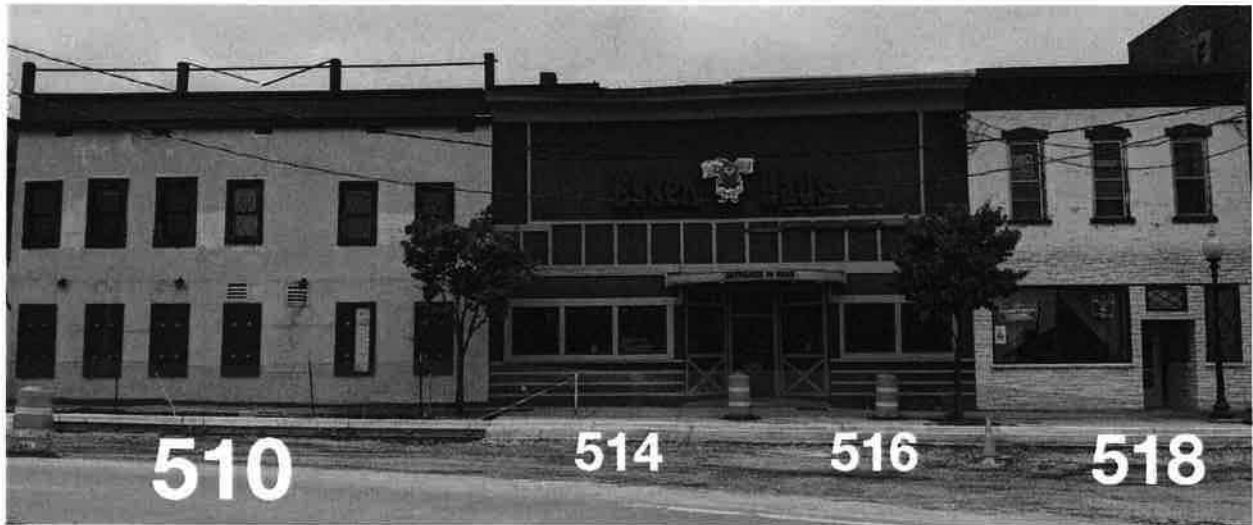

East Wilson Street Facade



Rear Facade

510 E Wilson
Exterior



510, 514 & 516 E Wilson
Interior



510, 514 & 516 E Wilson
Interior (cont.)



514-516 E Wilson
Exterior

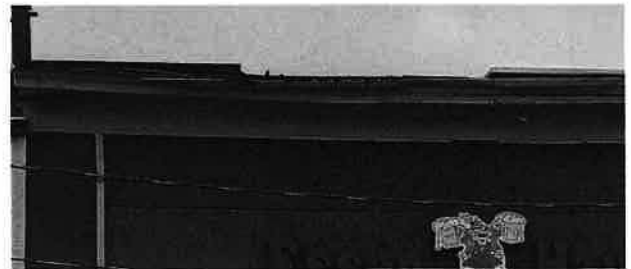

518 E Wilson
Exterior



518 E Wilson
Interior



518 E Wilson
Interior (cont.)



EXHIBIT D

MANAGEMENT PLAN

The East End

E. Wilson & Blair

Management Plan

Trash/Recycling Management

Trash and recycling dumpsters will be enclosed in the grade level parking garage and accessed from South Franklin Street. Commercial and residential tenants will bring trash/recycling to the refuse room. A private waste management company will be contracted to empty the trash/recycling 3-5 times per week during daytime hours.

Snow/Ice Removal

Snow/ice removal for sidewalks, driveway and entry areas will be contracted through a snow removal company. Property cleaning/maintenance staff will also maintain sidewalk as needed during the winter months.

Parking Management

Parking will be managed and monitored by the property manager for all on-site parking. City of Madison parking utility and private towing services will be used for parking enforcement.

Move-In/Move-Out

All tenant move-ins/outs will be coordinated and scheduled with management staff. Large moving trucks will be accommodated in the loading zone accessed from S. Franklin St. All move-ins/outs by car or truck will be accommodated within the parking structure.

Property Manager

McGrath Property Group
608-616-0705
info@mcgrathpropertygroup.com

EXHIBIT E:

TANDEM PARKING PLAN

The East End

E. Wilson & Blair

Tandem Parking Plan

1. Tandem parking stalls will be assigned to individual units.
2. Tandem parking stalls will be offered at a reduced rate compared to renting two individual stalls.
3. Tenants assigned a tandem parking stall will coordinate the use of the assigned stall.

CAS4
architecture, llc

4114 Regent Street, Suite 102
Madison, WI 53705
ph 608-708-1250

Project #: 19003.00
Project Name:
The East End
E. Wilson Street and Blair Street
Madison, WI 53703
Owner:
McGrath Property Group
730 Williamson Street, Suite 150
Madison, WI 53703

LAND USE APPLICATION SUBMITTAL
SUBMITTANT: CAS4/CPG
JUNE 24, 2019 - LANDMARKS COMMISSION MEETING FOR FINAL APPROVAL
JULY 10, 2019 - CITY COUNCIL MEETING FOR FINAL APPROVAL
AUGUST 16, 2019 - CITY COUNCIL MEETING

Issued for:
No. Description Date
1 Land Use Application 6-29-2019

Drawn by: CAS4 Architecture, LLC
Checked by: CAS4 Architecture, LLC

Overall Upper Level
Parking Plan

A102

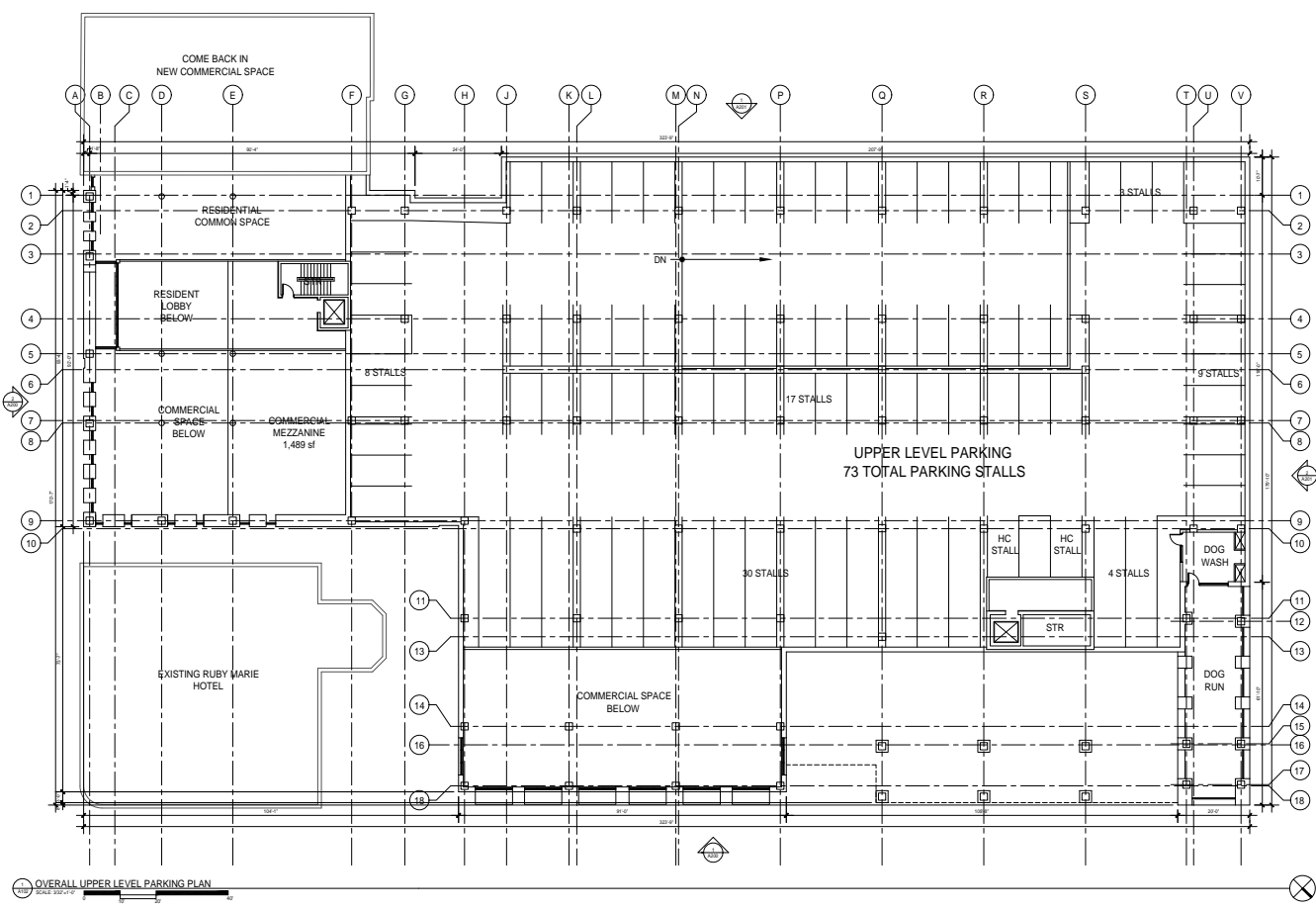

OVERALL UPPER LEVEL PARKING PLAN

Project #: 19003.00
 Project Name:
 The East End
 E. Wilson Street and Blair Street
 Madison, WI 53703
 Owner:
 McGrath Property Group
 730 Williamson Street, Suite 150
 Madison, WI 53703
 Issued for:
 No. Description Date
 1 Land Use Application 6-29-2019
 Drawn by: CAS4 Architecture, LLC
 Checked by: CAS4 Architecture, LLC
 Overall Upper Level
 Parking Plan
 A102



Building Rendered Images - E. Wilson Frontage from Willy St.

The East End - McGrath Property Group

May 29, 2019

© 2019

CāS₄
architecture, llc

19003.00

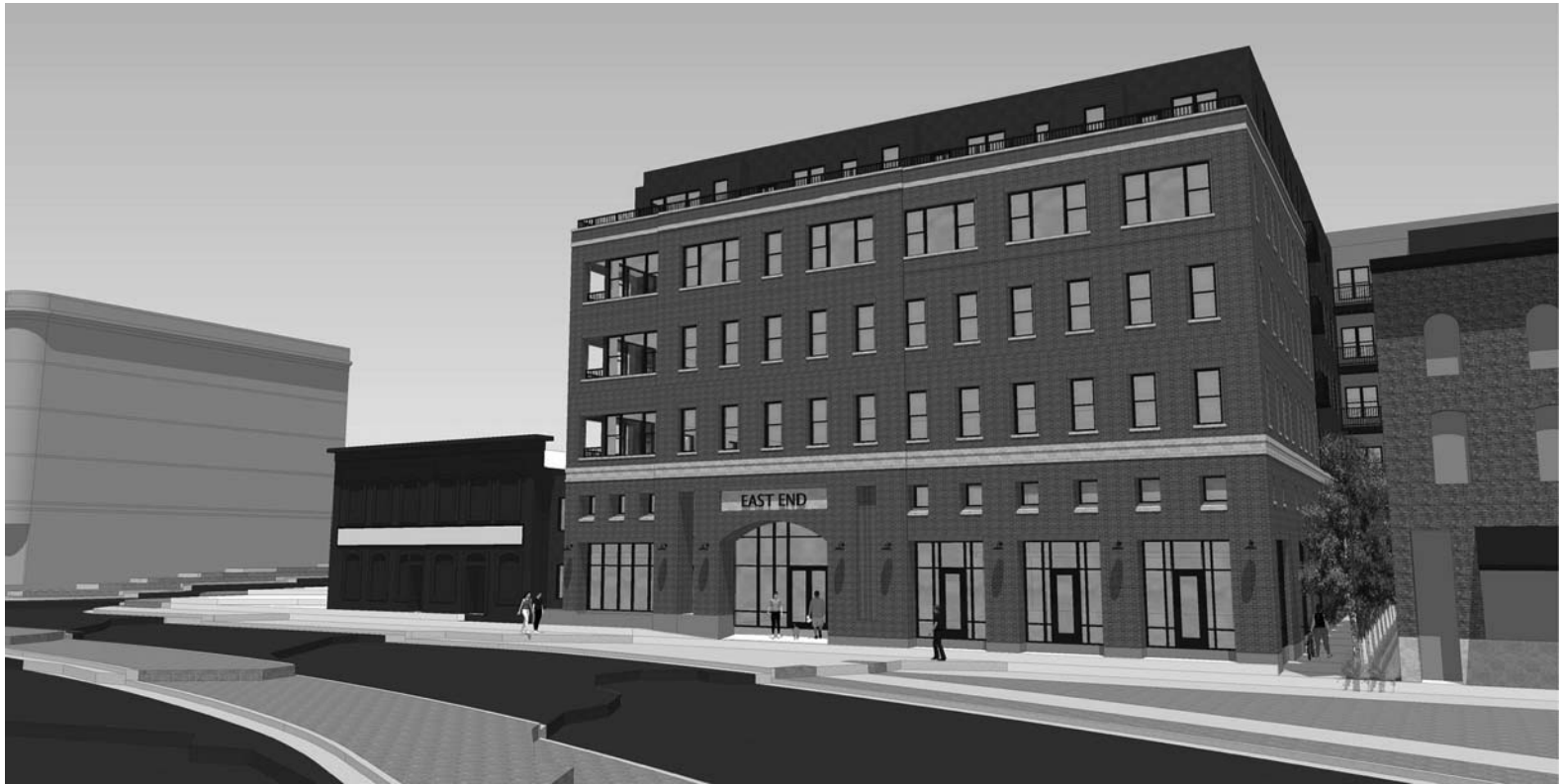

19003.00 | Building Rendered Images - E. Wilson Frontage & Passage

The East End - McGrath Property Group

May 29, 2019

© 2019

CāS₄
architecture, llc



Building Rendered Images - E. Wilson Frontage Close up

The East End - McGrath Property Group

May 29, 2019



19003.00

Building Rendered Images - Blair from MG&E to North

The East End - McGrath Property Group

May 29, 2019

© 2019

CāS₄
architecture, llc



Building Rendered Images - Blair / Entry from Railroad Street

The East End - McGrath Property Group

May 29, 2019

© 2019

CāS₄
architecture, llc

19003.00



19003.00

Building Rendered Images - Blair Entry @ Sidewalk

The East End - McGrath Property Group

May 29, 2019

© 2019

CāS₄
architecture, llc



Building Rendered Images - Blair towards Lake Monona

The East End - McGrath Property Group

May 29, 2019

© 2019

CāS₄
architecture, llc

19003.00



19003.00

Building Rendered Images - View from Franklin Street

The East End - McGrath Property Group

May 29, 2019

© 2019

CāS₄
architecture, llc



19003.00

Building Rendered Images - Back Aerial

The East End - McGrath Property Group

May 29, 2019

© 2019

CāS₄
architecture, llc



19003.00

Building Rendered Images - Townhouses from Germania

The East End - McGrath Property Group

May 29, 2019

© 2019

CāS₄
architecture, llc



Building Rendered Images - E. Wilson Frontage down Wilson St.

The East End - McGrath Property Group

May 29, 2019

© 2019

CāS₄
architecture, llc

19003.00



Building Height Relations along South Blair Street



Building Height Relations along East Wilson Street

E. Wilson and S. Blair Street Height Relations to Existing Buildings

The East End - McGrath Property Group

May 29, 2019



Cās₄
architecture, llc

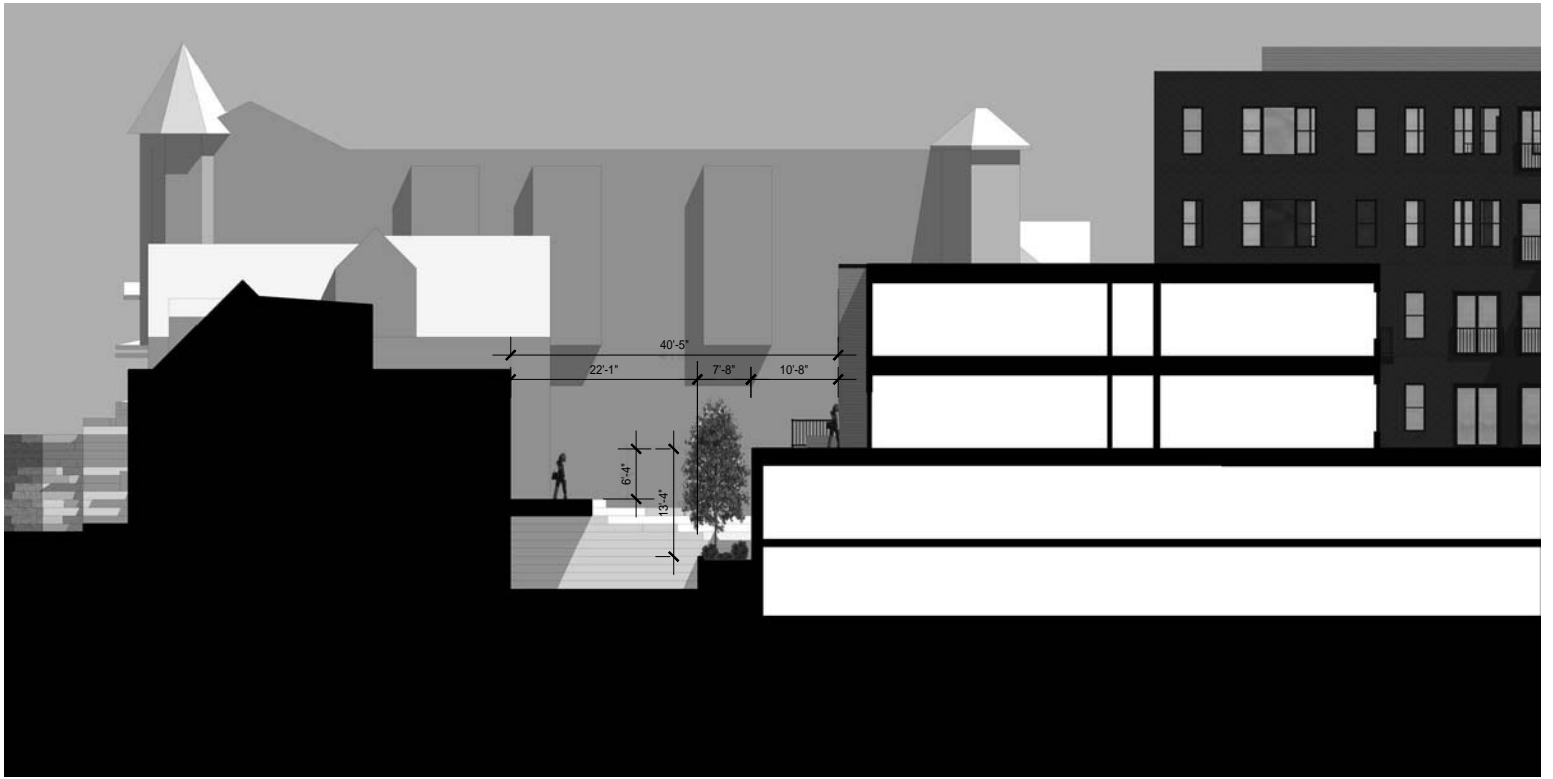

Section at Germania Condos to Illustrate Neighboring Condition and Compatible Scale

The East End - McGrath Property Group

May 29, 2019



CāS₄
architecture, llc

19003.00



SUN/SHADE ON DECEMBER 21st 9 A.M. - AS PROPOSED



SUN/SHADE ON DECEMBER 21st NOON - AS PROPOSED



SUN/SHADE ON DECEMBER 21st 5 P.M. - AS PROPOSED

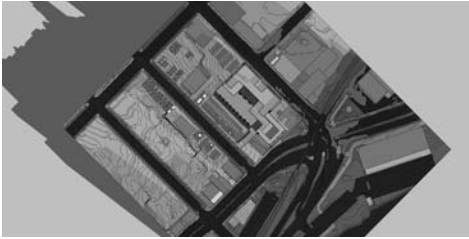

SUN/SHADE ON DECEMBER 21st 9 A.M. - AS PROPOSED

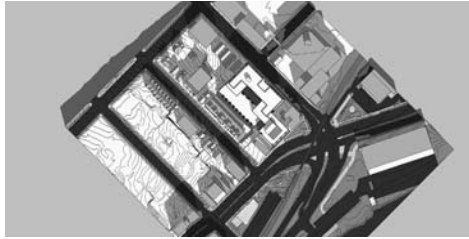

SUN/SHADE ON DECEMBER 21st NOON - AS PROPOSED

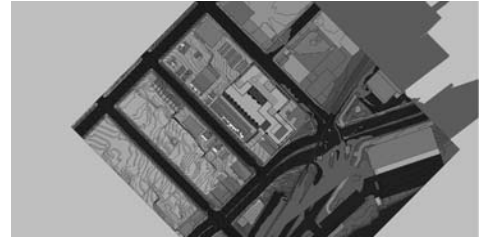

SUN/SHADE ON DECEMBER 21st 5 P.M. - AS PROPOSED

19003.00

Sun/Shade Study -- December 21st

The East End - McGrath Property Group

May 29, 2019



CāS₄
architecture, llc



SUN/SHADE ON MARCH 21st 9 A.M. - AS PROPOSED



SUN/SHADE ON MARCH 21st NOON - AS PROPOSED



SUN/SHADE ON MARCH 21st 5 P.M. - AS PROPOSED



SUN/SHADE ON MARCH 21st 9 A.M. - AS PROPOSED



SUN/SHADE ON MARCH 21st NOON - AS PROPOSED



SUN/SHADE ON MARCH 21st 5 P.M. - AS PROPOSED



SUN/SHADE ON JUNE 21st 9 A.M. - AS PROPOSED



SUN/SHADE ON JUNE 21st NOON - AS PROPOSED



SUN/SHADE ON JUNE 21st 5 P.M. - AS PROPOSED

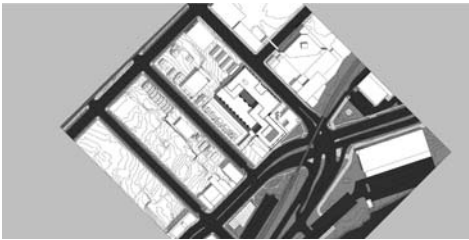

SUN/SHADE ON JUNE 21st 9 A.M. - AS PROPOSED

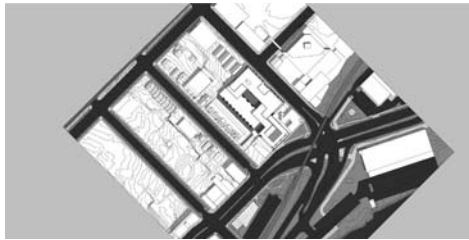

SUN/SHADE ON JUNE 21st NOON - AS PROPOSED

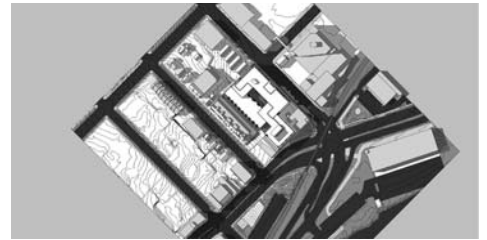

SUN/SHADE ON JUNE 21st 5 P.M. - AS PROPOSED

THE EAST END APARTMENTS LUMINAIRE SCHEDULE

TYPE	DESCRIPTION	CCT	NOMINAL DELIVERED LUMENS	NOMINAL WATTAGE	MFTR	MODEL #	NOTES
D1	RECESSED DOWNLIGHT. 6" APERTURE WITH REGRESSED LENS. SEMI-SPECULAR CLEAR REFLECTOR.	3500	1,500	14	HALO COMMERCIAL	PD6-15-D010B/PDM6B-835/61V-H	0-10V DIMMING
D2	RECESSED DOWNLIGHT. 4" APERTURE WITH REGRESSED LENS. SEMI-SPECULAR CLEAR REFLECTOR.	3500	950	1	HALO COMMERCIAL	HC4/10-D010/ HIM4-12-835/ 41WD-H	0-10V DIMMING
C1	COLOR CHANGING WET LOCATION TUBE LIGHT. PROVIDE WITH WALL-BOX TYPE DMX CONTROLLER.	N/A	5 LM - 40 LM PER FOOT	4 PER FOOT	BARRON	FBT-RGB/ XFMR-24-XX AS REQUIRED FOR INTALLATION FBT-RGB-LCH LINEAR CHANNEL PROVIDE WITH JUMPERS AND POWER CORDS AS REQUIRED FOR COMPLETE INSTALLATION. NICOLAUDIE STICK KE 1/ NICOLAUDIE POWER 4M FCC-16-WM-UNV-LED-35K-CR83-15L-BK-40	TO BE CONCEALED IN ARCHITECTURAL DETAIL. DMX CONTROL REQUIRED. 65' MAX RUN WITH ONE POWER SUPPLY PER END.
W1	WALL MOUNTED CYLINDRICAL EXTERIOR DOWNLIGHT. NOMINAL 40 DEGREE BEAMSPREAD. BLACK FINISH.	3500	1,235	20	FC LIGHTING		0-10V DIMMING
W2	WALL MOUNTED EXTERIOR RLM WITH ANODIZED CHARCOAL FINISH.	3500	1,820	21	BASELITE LIGHTING	ARBOR W517-61-SELECT ARM-61-21WLED	SELECT ARM W14, W18, W26 OR W35
W3	RECESSED IN-WALL EXTERIOR STEPLIGHT. BLACK FINISH.	3000	235	8	KUZCO	ER7108-BK	
W4	WALL MOUNTED EXTERIOR FULL CUTOFF AREA LIGHT.	4000	3,360	30	BARRON	E110-30-4K-BR-SC	
W5	SINGLE-GANG RECESSED STEPLIGHT. BLACK FINISH.	3000	76	4	FC LIGHTING	FCSL1015-120V-LED3K-7-BK-CL	

DESCRIPTION

Recessed 6-inch LED lens downlight is available in various distributions, lumen and CRI/CCT options. Suitable for commercial construction and can be used for both new or renovation work. Use for general area lighting where high efficiency and visual comfort are required.

Catalog #		Type
Project		
Comments		Date
Prepared by		

SPECIFICATION FEATURES

MECHANICAL

Frame

Boat shaped galvanized steel frame with adjustable plaster lip accommodates ceilings up to ½" - 2" thick. May be used for new construction or remodeling installations. Provided with (2) remodel clips to secure frame when installed from below the ceiling.

Mounting Brackets

Bar hanger receivers adjust 2" vertically from above the ceiling or thru the aperture. Use with No Fuss™ bar hangers or with ½" EMT. Removable to facilitate installation from below the ceiling.

No Fuss™ Bar Hangers

Captive preinstalled bar hanger locks to tee grid with a screwdriver or pliers. Centering mechanism allows consistent positioning of fixtures.

OPTICAL

LED Module

Proximity phosphors over chip on board LEDs provide a uniform source with high efficiency and no pixilation. Available in 80 or 90 CRI minimum, accuracy within 3 SDCM provides color uniformity. See ordering information for available CRI / CCT options. Passive thermal management achieves L70 at 50,000 hours in non IC applications. Integral diffuse lens provides visual shielding. Integral connector allows quick connection to housing flex.

Reflector

One piece parabolic aluminum reflector provides cutoff for a visually comfortable optic. Attaches to LED module with (3) speed clamps minimizing light leaks to lens. Self-flanged standard with an optional white painted flange.

Trim Retention

Reflectors are retained with two torsion springs holding the flange tightly to the finished ceiling surface.

ELECTRICAL Junction Box

(6) ½" and (2) ¾" trade size pry outs positioned to allow straight conduit runs. Listed for (12) #12 AWG (six in, six out) 90°C conductors and feed thru branch wiring.

Driver

Integral UNV 120 - 277V 50/60 Hz constant current driver provides noise free operation. For 347V input use Halo transformer H347 or H347200. Continuous, flicker-free dimming from 100% to 1% with 0 -10V analog control. Optional low voltage DC driver for use with Eaton's distributed low voltage power system.

Emergency Option

Provides 90 minutes of standby lighting meeting most life safety codes for egress lighting. Available with both integral or remote charge indicator and test switch.

Compliance

- cULus listed for wet location.
- IP66 Ingress Protection Rated.
- Non-IC rated for 2000 and 3000 Lumen fixtures. Insulation must be kept 3" from top and sides.
- IC rated for 1000 and 1500 Lumen fixtures.
- Airtight per ASTM-E283.
- Optional City of Chicago environmental air (CCEA) marking for plenum applications.
- EMI/RFI emissions per FCC 47CFR Part 18 non-consumer limits.
- Contains no mercury or lead and RoHS compliant.
- Photometric testing in accordance with IES LM-79-08.
- Lumen maintenance projections in accordance with IES LM-80-08 and TM-21-11.
- 80 CRI:
- Can be used to comply with California Title 24 Non-Residential Lighting Controls requirements as a LED Luminaire.
- ENERGY STAR® listed for commercial applications, reference database for current listings.

WARRANTY

Limited 5-year warranty, see website for details.
www.eaton.com/lighting/legal

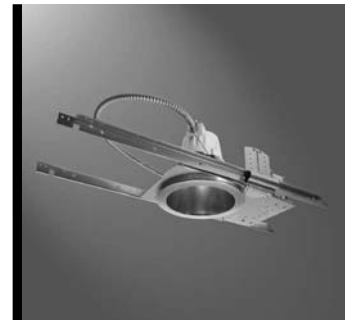

PD610
PD615
PD620
PD630

PDM6B

61V

**1000, 1500,
 2000 & 3000
 Lumen Series**

**LED
 6-Inch Aperture
 Lens Downlight**

THD: ≤ 20%
PF: ≥ 0.90
T Ambient -30 - +40°C
Sound Rating ≤ 20 dba

Lumens	1000 Series	
Input Voltage	120V	277V
Input Current	0.083A	0.041 A
Input Power	9.9 W	10.8 W
Efficacy	120 LPW	120 LPW
Inrush Current	0.53 A	1.3 A

Lumens	1500 Series	
Input Voltage	120V	277V
Input Current	0.114 A	0.053 A
Input Power	13.7 W	14.3 W
Efficacy	120 LPW	120 LPW
Inrush Current	0.63 A	1.7 A

Lumens	2000 Series	
Input Voltage	120V	277V
Input Current	0.166 A	0.079 A
Input Power	19.9 W	20.5 W
Efficacy	115 LPW	115 LPW
Inrush Current	0.59 A	2.7 A

Lumens	3000 Series	
Input Voltage	120V	277V
Input Current	0.232 A	0.103 A
Input Power	27.7 W	27.5 W
Efficacy	110 LPW	110 LPW
Inrush Current	0.73 A	2.9 A

ORDERING INFORMATION

SAMPLE NUMBER: PD610D010BREM-PDM6B827-61VC

A complete luminaire consists of a housing, LED module and reflector, order separately.

Housing	Lumens	Driver	Options
PD6 = 6" aperture LED downlight PD6CP = 6" aperture LED downlight, CCEA listed for City of Chicago plenum requirements	10 = 1,000 lumens (nominal) 15 = 1,500 lumens (nominal) 20 = 2,000 lumens (nominal) 30 = 3,000 lumens (nominal)	D010B = 120-277V 50/60Hz, 0-10V dimming DLV = Low voltage dimming driver. For use with Eaton DLVP system only.	REM = 7W Emergency operation with remote indicator and test switch (D010B only) ¹ IEM = 7W Emergency operation with integral indicator and test switch (D010B only) ¹ REMV7 = 7W low voltage emergency module with remote test switch (DLV only) ^{1,2} REMV14 = 14W low voltage emergency module with remote test switch (DLV only) ^{1,2} IEMV7 = 7W low voltage emergency module with integral test switch (DLV only) ^{1,2} IEMV14 = 14W low voltage emergency module with integral test switch (DLV only) ^{1,2} LWTPD1 = Factory installed LumaWatt Pro Wireless Sensor Kit (D010B only) ¹ SWPD1 = Factory installed WaveLinX tilemount daylight sensor includes control module, sensor, cable and tile mount (D010B only) ¹

LED Module

PDM6B = Downlight LED module for PD6 housing, provides 1,000, 1,500, 2,000, or 3,000 lumens (nominal) depending on connected housing type

CRI/CCT

827 = 80 CRI, 2700K CCT
927 = 90 CRI, 2700K CCT
830 = 80 CRI, 3000K CCT
930 = 90 CRI, 3000K CCT
835 = 80 CRI, 3500K CCT
935 = 90 CRI, 3500K CCT
840 = 80 CRI, 4000K CCT
940 = 90 CRI, 4000K CCT

Reflector

61V = 6" vertical parabolic reflector
61VEM = 6" vertical parabolic reflector for IEM

Finish Option

C = Specular clear
G = Specular gold
H = Semi-specular clear
W = White (white flange)
BB = Black baffle (white flange)
WB = White baffle (white flange)

Flange Option

Blank = Polished flange standard with C, G & H reflector finishes
Blank = White flange standard with W, BB, & WB
WF = White flange option available with C, G, & H reflector finishes

Accessories

HB128APK = L channel hanger bar, 26", 'No-Fuss', pair (replacement)
RMB22 = Adjustable wood joist mounting bars, pair extend 22" long
H347 = Step down transformer for 347V input
H347 = Step down transformer for 347V input, 75VA max
H347200 = Step down transformer for 347V input, 200VA max
PORLWTPD1 = LumaWatt Pro Wireless Sensor Kit (D010B only)¹
TMSWPD1 = WaveLinX tilemount daylight sensor, includes control module, sensor, cable and tile mount (D010B only)¹

Notes: 1. Not available with CP version.
 2. ULus for U.S. only.

DIMENSIONS

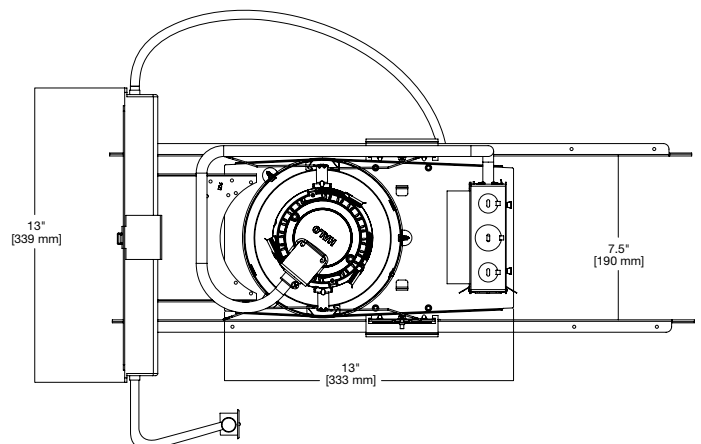
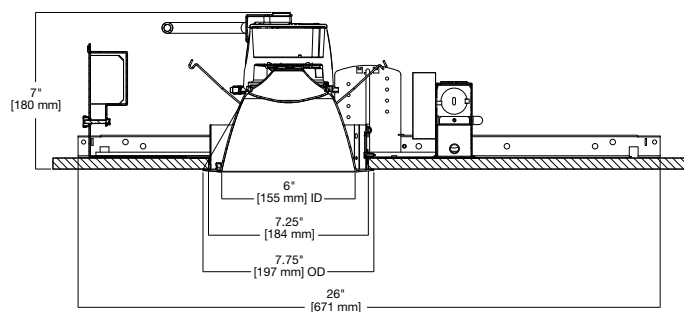
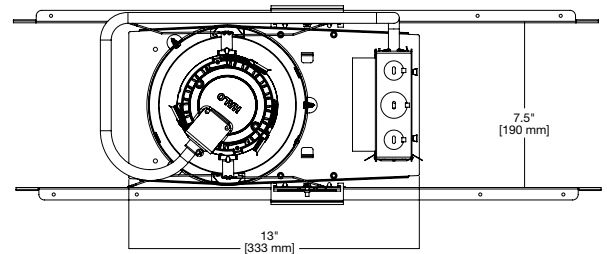
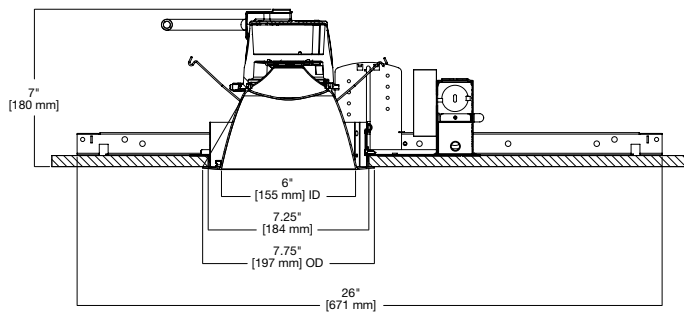

COMPLIANCE TABLE

1000 LUMEN

80 CRI								
Catalog #	PD610D010B-PDM6B827		PD610D010B-PDM6B830		PD610D010B-PDM6B835		PD610D010B-PDM6B840	
	LUMENS	LPW	LUMENS	LPW	LUMENS	LPW	LUMENS	LPW
61VC	1102	111	1169	118	1200	121	1223	124
61VCWF	1078	109	1143	115	1174	119	1196	121
61VG	1077	109	1142	115	1172	118	1195	121
61VGWF	1033	104	1095	111	1125	114	1146	116
61VH	1009	102	1069	108	1098	111	1119	113
61VHWF	1007	102	1067	108	1096	111	1117	113
61VW	1113	112	1181	119	1212	122	1235	125
61VBB	946	96	1003	101	1030	104	1050	106
61VWB	1066	108	1131	114	1161	117	1183	119

90 CRI								
Catalog #	PD610D010B-PDM6B927		PD610D010B-PDM6B930		PD610D010B-PDM6B935		PD610D010B-PDM6B940	
	LUMENS	LPW	LUMENS	LPW	LUMENS	LPW	LUMENS	LPW
61VC	941	95	995	100	1053	106	1069	108
61VCWF	920	93	973	98	1030	104	1045	106
61VG	919	93	972	98	1029	104	1044	105
61VGWF	881	89	932	94	987	100	1002	101
61VH	861	87	910	92	963	97	978	99
61VHWF	859	87	908	92	962	97	976	99
61VW	950	96	1005	101	1063	107	1080	109
61VBB	807	82	854	86	904	91	918	93
61VWB	910	92	962	97	1019	103	1034	104

1500 LUMEN

80 CRI								
Catalog #	PD615D010B-PDM6B827		PD615D010B-PDM6B830		PD615D010B-PDM6B835		PD615D010B-PDM6B840	
	LUMENS	LPW	LUMENS	LPW	LUMENS	LPW	LUMENS	LPW
61VC	1497	109	1587	116	1630	119	1660	121
61VCWF	1464	107	1552	113	1593	116	1624	119
61VG	1462	107	1550	113	1592	116	1622	118
61VGWF	1402	102	1487	109	1527	111	1556	114
61VH	1369	100	1452	106	1491	109	1519	111
61VHWF	1367	100	1449	106	1488	109	1516	111
61VW	1512	110	1603	117	1646	120	1677	122
61VBB	1285	94	1362	99	1399	102	1425	104
61VWB	1448	106	1535	112	1576	115	1606	117

90 CRI								
Catalog #	PD615D010B-PDM6B927		PD615D010B-PDM6B930		PD615D010B-PDM6B935		PD615D010B-PDM6B940	
	LUMENS	LPW	LUMENS	LPW	LUMENS	LPW	LUMENS	LPW
61VC	1277	93	1350	99	1429	104	1451	106
61VCWF	1249	91	1321	96	1398	102	1419	104
61VG	1247	91	1319	96	1396	102	1417	103
61VGWF	1197	87	1265	92	1339	98	1360	99
61VH	1168	85	1235	90	1308	95	1328	97
61VHWF	1166	85	1233	90	1305	95	1325	97
61VW	1290	94	1364	100	1444	105	1466	107
61VBB	1096	80	1159	85	1227	90	1246	91
61VWB	1235	90	1306	95	1383	101	1404	102

COMPLIANCE TABLE continued

2000 LUMEN

80 CRI								
Catalog #	PD620D010B-PDM6B827		PD620D010B-PDM6B830		PD620D010B-PDM6B835		PD620D010B-PDM6B840	
	LUMENS	LPW	LUMENS	LPW	LUMENS	LPW	LUMENS	LPW
61VC	2119	106	2247	113	2307	116	2351	118
61VCWF	2072	104	2197	110	2256	113	2299	116
61VG	2070	104	2194	110	2253	113	2296	115
61VGWF	1985	100	2105	106	2162	109	2202	111
61VH	1938	97	2055	103	2111	106	2150	108
61VHWF	1935	97	2052	103	2107	106	2147	108
61VW	2140	108	2269	114	2330	117	2374	119
61VBB	1819	91	1929	97	1980	100	2018	101
61VWB	2050	103	2173	109	2232	112	2274	114

90 CRI								
Catalog #	PD620D010B-PDM6B927		PD620D010B-PDM6B930		PD620D010B-PDM6B935		PD620D010B-PDM6B940	
	LUMENS	LPW	LUMENS	LPW	LUMENS	LPW	LUMENS	LPW
61VC	1808	91	1912	96	2024	102	2055	103
61VCWF	1768	89	1870	94	1979	99	2009	101
61VG	1766	89	1868	94	1977	99	2007	101
61VGWF	1694	85	1791	90	1896	95	1925	97
61VH	1654	83	1749	88	1852	93	1880	94
61VHWF	1651	83	1746	88	1848	93	1876	94
61VW	1826	92	1931	97	2044	103	2075	104
61VBB	1552	78	1641	82	1737	87	1764	89
61VWB	1749	88	1850	93	1958	98	1988	100

3000 LUMEN

80 CRI								
Catalog #	PD630D010B-PDM6B827		PD630D010B-PDM6B830		PD630D010B-PDM6B835		PD630D010B-PDM6B840	
	LUMENS	LPW	LUMENS	LPW	LUMENS	LPW	LUMENS	LPW
61VC	2763	100	2929	107	3008	109	3065	111
61VCWF	2701	98	2864	104	2941	107	2997	109
61VG	2698	98	2861	104	2938	107	2993	109
61VGWF	2588	94	2744	100	2818	102	2871	104
61VH	2527	92	2680	97	2752	100	2804	102
61VHWF	2523	92	2675	97	2747	100	2798	102
61VW	2790	101	2958	108	3038	110	3095	113
61VBB	2371	86	2514	91	2582	94	2631	96
61VWB	2672	97	2833	103	2910	106	2965	108

90 CRI								
Catalog #	PD630D010B-PDM6B927		PD630D010B-PDM6B930		PD630D010B-PDM6B935		PD630D010B-PDM6B940	
	LUMENS	LPW	LUMENS	LPW	LUMENS	LPW	LUMENS	LPW
61VC	2357	86	2493	91	2639	96	2679	97
61VCWF	2305	84	2438	89	2580	94	2619	95
61VG	2302	84	2435	89	2577	94	2616	95
61VGWF	2209	80	2336	85	2472	90	2510	91
61VH	2156	78	2280	83	2414	88	2450	89
61VHWF	2152	78	2276	83	2409	88	2446	89
61VW	2381	87	2518	92	2665	97	2705	98
61VBB	2023	74	2140	78	2265	82	2299	84
61VWB	2280	83	2411	88	2552	93	2591	94

PHOTOMETRY - 1000 lumen / 80 CRI

PD610D010B-PDM6B835-61VC
Spacing Criteria = 0.72
Lumens per Watt = 121.2 Lm/W
Test No. P215328
Test Model: PD610D010B-PDM6B835-61VC

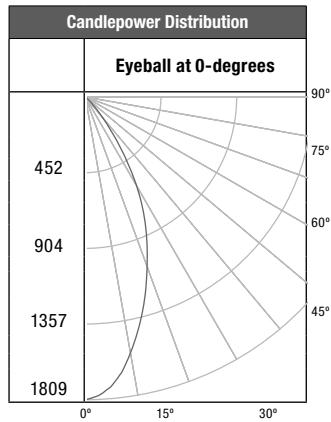

Candela Distribution	
Degrees Vertical	Candela
0*	1809
5	1739
10	1553
20	1077
30	611
40	160
50	18
60	3
70	1
80	0
90	0

*CBCP

Luminance (Average Candela/M ²)	
Degree	Avg. 0° Luminance
45	4528
55	507
65	169
75	148
85	0

Cone of Light Footcandles			
Distance to Illuminated Plane	Initial Nadir Footcandles	Beam (ft.)	
		L Length	W Width
5.5'	59.8	3.8	3.8
7'	36.9	5	5
8'	28.3	5.6	5.6
9'	22.3	6.4	6.4
10'	18.1	7.2	7.2
12'	12.6	8.6	8.6

Beam diameter is to 50% of maximum footcandles, rounded to the nearest half-foot. Footcandle values are initial, apply appropriate light loss factors where necessary.

Zonal Lumen Summary		
Zone	Lumens	% Fixture
0-30	914	76.1
0-40	1139	94.9
0-60	1198	99.8
0-90	1200	100

PHOTOMETRY - 1000 lumen / 90 CRI

PD610D010B-PDM6B935-61VC
Spacing Criteria = 0.72
Lumens per Watt = 106.4 Lm/W
Test No. P215332
Test Model: PD610D010B-PDM6B935-61VC

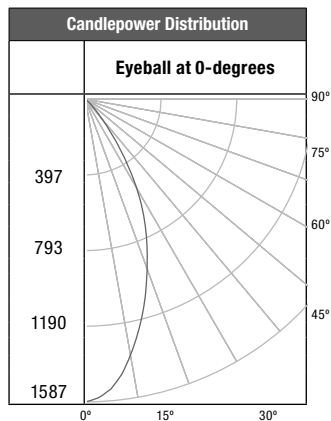

Candela Distribution	
Degrees Vertical	Candela
0*	1587
5	1526
10	1363
20	945
30	536
40	140
50	16
60	2
70	1
80	0
90	0

*CBCP

Luminance (Average Candela/M ²)	
Degree	Avg. 0° Luminance
45	3969
55	449
65	156
75	127
85	0

Cone of Light Footcandles			
Distance to Illuminated Plane	Initial Nadir Footcandles	Beam (ft.)	
		L Length	W Width
5.5'	52.5	3.8	3.8
7'	32.4	5	5
8'	24.8	5.6	5.6
9'	19.6	6.4	6.4
10'	15.9	7.2	7.2
12'	11	8.6	8.6

Beam diameter is to 50% of maximum footcandles, rounded to the nearest half-foot. Footcandle values are initial, apply appropriate light loss factors where necessary.

Zonal Lumen Summary		
Zone	Lumens	% Fixture
0-30	802	76.1
0-40	999	94.9
0-60	1051	99.8
0-90	1053	100

PHOTOMETRY - 1500 lumen / 80 CRI

PD615D010B-PDM6B835-61VC

Spacing Criteria = 0.72

Lumens per Watt = 118.9 Lm/W

Test No. P215312

Test Model: PD615D010B-PDM6B835-61VC

Candlepower Distribution

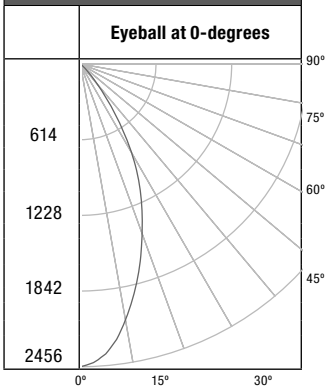

Candela Distribution	
Degrees Vertical	Candela
0*	2456
5	2361
10	2109
20	1463
30	830
40	217
50	24
60	4
70	1
80	0
90	0

*CBCP

Luminance	
(Average Candela/M ²)	
Degree	Avg. 0° Luminance
45	6148
55	688
65	233
75	191
85	0

Cone of Light Footcandles			
Distance to Illuminated Plane	Initial Nadir Footcandles	Beam (ft.)	
		L Length	W Width
5.5'	81.2	3.8	3.8
7'	50.1	5	5
8'	38.4	5.6	5.6
9'	30.3	6.4	6.4
10'	24.6	7.2	7.2
12'	17.1	8.6	8.6

Beam diameter is to 50% of maximum footcandles, rounded to the nearest half-foot. Footcandle values are initial, apply appropriate light loss factors where necessary.

Zonal Lumen Summary		
Zone	Lumens	% Fixture
0-30	1241	76.1
0-40	1546	94.9
0-60	1627	99.8
0-90	1629	100

PHOTOMETRY - 1500 lumen / 90 CRI

PD615D010B-PDM6B935-61VC

Spacing Criteria = 0.72

Lumens per Watt = 104.3 Lm/W

Test No. P215316

Test Model: PD615D010B-PDM6B935-61VC

Candlepower Distribution

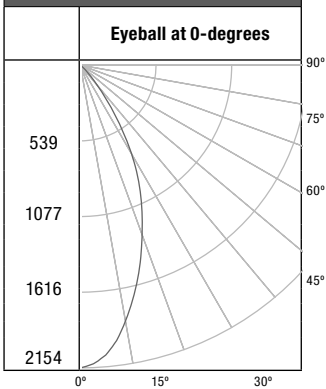

Candela Distribution	
Degrees Vertical	Candela
0*	2154
5	2071
10	1850
20	1283
30	728
40	190
50	21
60	3
70	1
80	0
90	0

*CBCP

Luminance	
(Average Candela/M ²)	
Degree	Avg. 0° Luminance
45	5396
55	602
65	208
75	169
85	0

Cone of Light Footcandles			
Distance to Illuminated Plane	Initial Nadir Footcandles	Beam (ft.)	
		L Length	W Width
5.5'	71.2	3.8	3.8
7'	44	5	5
8'	33.7	5.6	5.6
9'	26.6	6.4	6.4
10'	21.5	7.2	7.2
12'	15	8.6	8.6

Beam diameter is to 50% of maximum footcandles, rounded to the nearest half-foot. Footcandle values are initial, apply appropriate light loss factors where necessary.

Zonal Lumen Summary		
Zone	Lumens	% Fixture
0-30	1088	76.1
0-40	1356	94.9
0-60	1427	99.8
0-90	1429	100

PHOTOMETRY - 2000 lumen / 80 CRI

PD620D010B-PDM6B835-61VC

Spacing Criteria = 0.72
Lumens per Watt = 115.9 Lm/W
Test No. P215296
Test Model: PD620D010B-PDM6B835-61VC

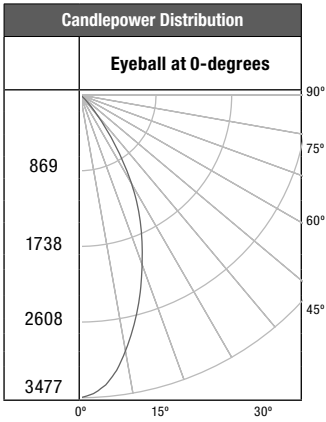

Candela Distribution	
Degrees Vertical	Candela
0*	3477
5	3343
10	2986
20	2071
30	1175
40	308
50	34
60	5
70	1
80	0
90	0

*CBCP

Luminance	
(Average Candela/M ²)	
Degree	Avg. 0° Luminance
45	8706
55	975
65	337
75	275
85	0

Cone of Light Footcandles			
Distance to Illuminated Plane	Initial Nadir Footcandles	Beam (ft.)	
		L Length	W Width
5.5'	114.9	3.8	3.8
7'	71	5	5
8'	54.3	5.6	5.6
9'	42.9	6.4	6.4
10'	34.8	7.2	7.2
12'	24.1	8.6	8.6

Beam diameter is to 50% of maximum footcandles, rounded to the nearest half-foot. Footcandle values are initial, apply appropriate light loss factors where necessary.

Zonal Lumen Summary		
Zone	Lumens	% Fixture
0-30	1757	76.1
0-40	2189	94.9
0-60	2303	99.8
0-90	2307	100

PHOTOMETRY - 2000 lumen / 90 CRI

PD620D010B-PDM6B935-61VC

Spacing Criteria = 0.72
Lumens per Watt = 101.7 Lm/W
Test No. P215300
Test Model: PD620D010B-PDM6B935-61VC

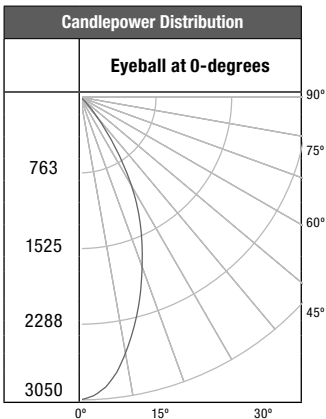

Candela Distribution	
Degrees Vertical	Candela
0*	3050
5	2932
10	2619
20	1817
30	1031
40	270
50	30
60	4
70	1
80	0
90	0

*CBCP

Luminance	
(Average Candela/M ²)	
Degree	Avg. 0° Luminance
45	7636
55	860
65	285
75	233
85	0

Cone of Light Footcandles			
Distance to Illuminated Plane	Initial Nadir Footcandles	Beam (ft.)	
		L Length	W Width
5.5'	100.8	3.8	3.8
7'	62.2	5	5
8'	47.7	5.6	5.6
9'	37.7	6.4	6.4
10'	30.5	7.2	7.2
12'	21.2	8.6	8.6

Beam diameter is to 50% of maximum footcandles, rounded to the nearest half-foot. Footcandle values are initial, apply appropriate light loss factors where necessary.

Zonal Lumen Summary		
Zone	Lumens	% Fixture
0-30	1541	76.1
0-40	1920	94.9
0-60	2020	99.8
0-90	2024	100

PHOTOMETRY - 3000 lumen / 80 CRI

PD630D010B-PDM6B835-61VC

Spacing Criteria = 0.72

Lumens per Watt = 109.4 Lm/W

Test No. P215344

Test Model: PD630D010B-PDM6B835-61VC

Candlepower Distribution

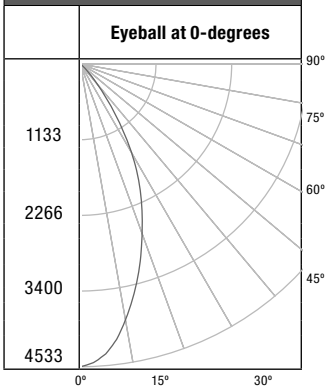

Candela Distribution	
Degrees Vertical	Candela
0*	4533
5	4358
10	3892
20	2700
30	1532
40	401
50	45
60	7
70	2
80	0
90	0

*CBCP

Luminance

(Average Candela/M ²)	
Degree	Avg. 0° Luminance
45	11350
55	1271
65	428
75	360
85	0

Cone of Light Footcandles

Distance to Illuminated Plane	Initial Nadir Footcandles	Beam (ft.)	
		L Length	W Width
5.5'	149.8	3.8	3.8
7'	92.5	5	5
8'	70.8	5.6	5.6
9'	56	6.4	6.4
10'	45.3	7.2	7.2
12'	31.5	8.6	8.6

Beam diameter is to 50% of maximum footcandles, rounded to the nearest half-foot. Footcandle values are initial, apply appropriate light loss factors where necessary.

Zonal Lumen Summary

Zone	Lumens	% Fixture
0-30	2290	76.1
0-40	2854	94.9
0-60	3002	99.8
0-90	3008	100

PHOTOMETRY - 3000 lumen / 90 CRI

PD630D010B-PDM6B935-61VC

Spacing Criteria = 0.72

Lumens per Watt = 95.9 Lm/W

Test No. P215348

Test Model: PD630D010B-PDM6B935-61VC

Candlepower Distribution

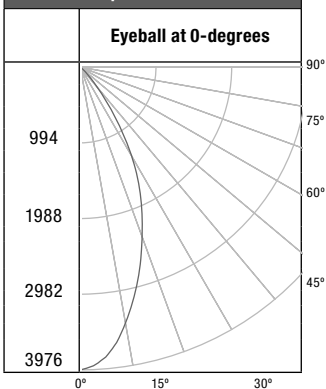

Candela Distribution	
Degrees Vertical	Candela
0*	3976
5	3823
10	3415
20	2368
30	1344
40	352
50	39
60	6
70	2
80	0
90	0

*CBCP

Luminance

(Average Candela/M ²)	
Degree	Avg. 0° Luminance
45	9955
55	1118
65	376
75	318
85	0

Cone of Light Footcandles

Distance to Illuminated Plane	Initial Nadir Footcandles	Beam (ft.)	
		L Length	W Width
5.5'	131.5	3.8	3.8
7'	81.2	5	5
8'	62.1	5.6	5.6
9'	49.1	6.4	6.4
10'	39.8	7.2	7.2
12'	27.6	8.6	8.6

Beam diameter is to 50% of maximum footcandles, rounded to the nearest half-foot. Footcandle values are initial, apply appropriate light loss factors where necessary.

Zonal Lumen Summary

Zone	Lumens	% Fixture
0-30	2009	76.1
0-40	2504	94.9
0-60	2634	99.8
0-90	2639	100

DESCRIPTION

Recessed 4-inch LED downlight provides narrow, medium or wide distribution patterns ideal for general area lighting. Lumen packages range from 1000 to 4000 lumens in color temperatures of 2700K, 3000K, 3500K, and 4000K; in 80 or 90CRI. Luminaire is airtight and can be installed in new construction or below the finished ceiling in remodeling applications. Intended applications include office spaces, healthcare, hospitality, schools, house of worship and other institutional uses.

Catalog #		Type
Project		
Comments		Date
Prepared by		

SPECIFICATION FEATURES

Housing Frame

- Boat shaped galvanized steel plaster frame with adjustable plaster lip accommodates 1/2" to 1-1/2" thick ceilings
- May be installed in new construction; or from below the finished (non-accessible) ceiling in remodeling.
- Provided with (2) old work remodel clips to secure the frame to the ceiling

Universal Mounting Bracket

- Mounting bracket adjusts 2" vertically from above the ceiling or thru the aperture
- Use with the included mounting bars or with 1/2" EMT
- Removable to facilitate installation from below the finished ceiling

Mounting Bars

- Captive preinstalled No Fuss™ mounting bars lock to tee grid with screwdriver or pliers
- Centering mechanism allows for consistent positioning of fixtures

LED Module

- Proximity phosphors over chip on board LEDs provide a uniform source with high efficiency and no pixilation
- Available in 80 or 90 CRI minimum, accuracy within 3 SDCM provides color uniformity
- 90 CRI, R9>50 (refer to chromaticity tech sheet online for details www.eaton.com/lighting)
- Correlated color temperature options
 - 2700K
 - 3000K
 - 3500K
 - 4000K
- Passive thermal management achieves L70 at 50,000 hours in IC and non IC applications
- Integral diffuse lens provides visual shielding
- Integral connector allows quick connection to housing flex

Lumen Options

- Nominal lumen values
 - 1000 lm
 - 1500 lm
 - 2000 lm
 - 3000 lm
 - 4000 lm

Reflector

- Self-flanged aluminum reflectors are available in narrow, medium or wide distribution patterns
- Medium distribution polymer non-conductive reflector may be used to meet local codes for 'dead front' applications
- Wall wash reflector features a rotatable insert assembly with integral linear spread lens for alignment of vertical illumination.
- Reflectors attach to LED module with (3) speed clamps
- Multiple painted or plated finishes are available

Reflector / Module Retention

- Reflector / module assembly is securely retained in the housing with (2) torsion springs

Driver

- Field replaceable constant current driver provides low noise operation
- UNV 120-277VAC 50/60Hz input standard
- Continuous, flicker-free 1% - 100% dimming with 0 -10V analog control
- Optional low voltage DC driver for use with Eaton's DLVP distributed low voltage power system combines power and control

Emergency Option

- Provides 90 minutes of standby lighting meeting most life safety codes for egress lighting
- Available with integral or remote charge indicator and test switch

Connected Lighting System Options

- WaveLinX tile mount daylight sensor includes control module, sensor and cable providing comprehensive lighting control
- LumaWatt Pro (powered by Enlighted) wireless tile mount sensor and control kit

Junction Box

- Galvanized steel junction box
- 20in³ internal volume excluding voltage barrier
- 25 in³ internal total volume
- Voltage barrier for 0-10V dimming wires [occupies (1) 1/2" pry-out space]
- Listed for (8) #12 AWG (four in, four out) 90° C conductors and feed-thru branch wiring
- (3) 1/2" and (2) 3/4" trade size pry-outs available
- (3) 4-port push wire nuts for mains voltage, with 1-port for fixture connection

Compliance

- cULus damp and wet location listed in protected ceilings; and IP20 - Above finished ceiling; IP64 - Below finished ceiling
- Non-IC rated for 2000, 3000 and 4000 lumen models. Insulation must be kept 3" from top and sides.
- IC rated for 1000 and 1500 lumen models, and suitable for direct contact to air permeable insulation
- Not for use in direct contact with spray foam insulation, consult NEMA LSD57-2013
- Airtight per ASTM-E283-04
- Suitable for use in clothes closets when installed in accordance with the NEC 410.16 spacing requirements
- EMI/RFI emissions per FCC 47CFR Part 15 non-consumer limits
- Contains no mercury or lead and RoHS compliant
- Photometric testing in accordance of IES LM-79-08
- Lumen maintenance projection in accordance of IES LM-80-08 and TM-21-11
- 1000 and 1500 lumen 90CRI ICAT models may be used to comply with State of California Title 24 residential code, with JA8-2016-E database certification
- May be used to comply with State of California Title 24 non-residential code, as a dimmable LED luminaire
- ENERGY STAR certified, reference certified light fixtures database

Warranty

- Five year limited warranty, consult website for details. www.eaton.com/lighting/legal

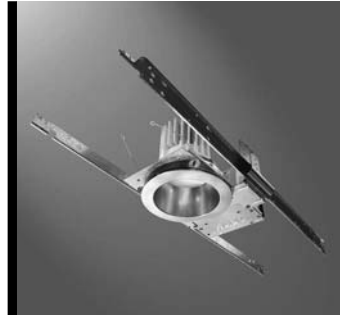

HC4
Housing Frame

HM4
LED Module

41
41PS
Series Reflectors

4-inch Lens Downlight
and Lens Wall Wash

1000/1500/2000/
3000/4000 Lumen



ENERGY DATA

Series	1000 lumen	
Input Voltage (VAC)	120V	277V
Input Current (A)	0.085	0.042
Input Power (W)	10.1	10.9
In-rush Current (A)	0.644	1.95
In-rush Duration (ms)	0.125	0.24
THDi (%)	8.6	15.6
PF:	≥ 0.90	
(Nominal input 120-277VAC & 100% of rated output power)		
Minimum starting temperature -40°C (-40°F)		
Sound Rating: Class A standards		

Series	1500 lumen	
Input Voltage (VAC)	120V	277V
Input Current (A)	0.119	0.055
Input Power (W)	14.2	14.9
In-rush Current (A)	0.212	0.85
In-rush Duration (ms)	0.28	0.32
THDi (%)	7.8	16.3
PF:	≥ 0.90	
(Nominal input 120-277VAC & 100% of rated output power)		
Minimum starting temperature -40°C (-40°F)		
Sound Rating: Class A standards		

Series	2000 lumen	
Input Voltage (VAC)	120V	277V
Input Current (A)	0.176	0.082
Input Power (W)	21.1	21.4
In-rush Current (A)	0.588	0.624
In-rush Duration (ms)	0.3	0.38
THDi (%)	8.8	11.2
PF:	≥ 0.90	
(Nominal input 120-277VAC & 100% of rated output power)		
Minimum starting temperature -40°C (-40°F)		
Sound Rating: Class A standards		

Series	3000 lumen	
Input Voltage (VAC)	120V	277V
Input Current (A)	0.228	0.102
Input Power (W)	27.2	27
In-rush Current (A)	0.898	1.7
In-rush Duration (ms)	0.36	0.38
THDi (%)	9.7	9.3
PF:	≥ 0.90	
(Nominal input 120-277VAC & 100% of rated output power)		
Minimum starting temperature -40°C (-40°F)		
Sound Rating: Class A standards		

Series	4000 lumen	
Input Voltage (VAC)	120V	277V
Input Current (A)	0.345	0.15
Input Power (W)	41.3	40.7
In-rush Current (A)	1.05	2.23
In-rush Duration (ms)	0.32	0.34
THDi (%)	10.06	14.01
PF:	≥ 0.90	
(Nominal input 120-277VAC & 100% of rated output power)		
Minimum starting temperature -40°C (-40°F)		
Sound Rating: Class A standards		

DIMENSIONS

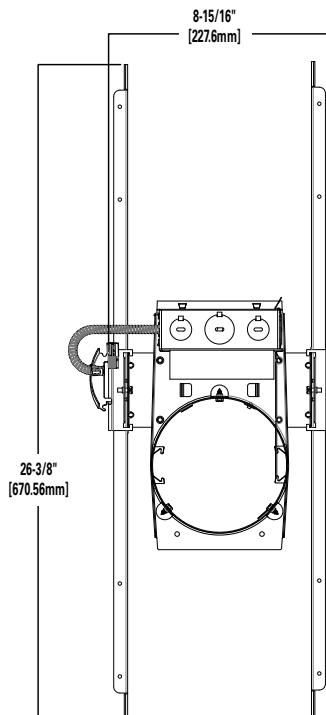

NEW CONSTRUCTION - HIGH LUMEN
3000 AND 4000 LUMEN

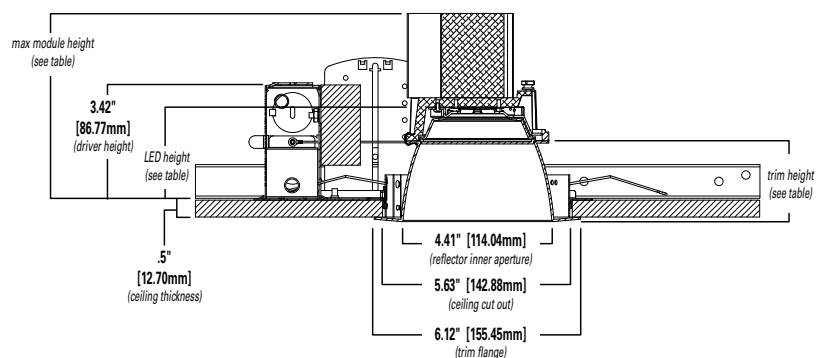

NEW CONSTRUCTION - LOW LUMEN
1000, 1500, AND 2000 LUMENS

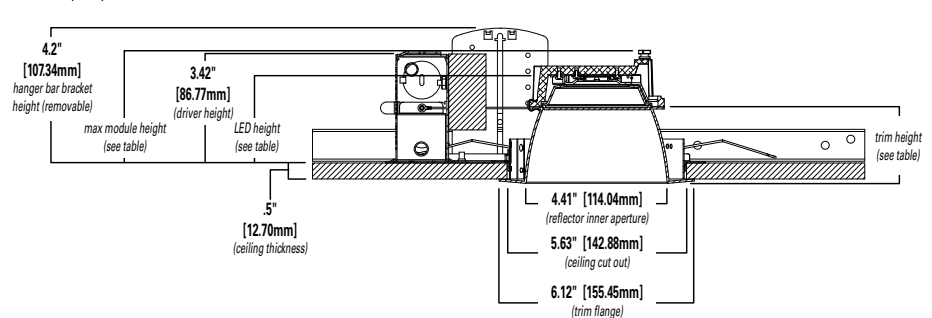

High Lumen (3000 & 4000 Lumens)

Distribution	Max. Module Height	Trim Height	LED Height
Narrow	5.6"	2.5"	2.9"
Medium	5.7"	2.6"	3.0"
Wide	5.5"	2.4"	2.8"
Baffle	5.5"	2.4"	2.8"

Low Lumen (1000, 1500 & 2000 Lumens)*

Max. Module Height	Trim Height	LED Height
3.6"	2.5"	2.7"
3.7"	2.6"	2.8"
3.5"	2.4"	2.6"
3.1"	2.4"	2.6"

*Max. height w/hanger bar bracket 4.2"

Ordering Information

Sample Number: HC420D010REM7 - HM412835 - 41MDC

A complete luminaire consists of a housing frame, LED module, and reflector (ordered separately)

Mounting Frame	Lumens	Input / Control
HC4 = 4" new construction and remodeler housing HC4CP = 4" new construction and remodeler housing, CCEA Chicago Plenum rated	10 = 1000 lumens (nominal) 15 = 1500 lumens (nominal) 20 = 2000 lumens (nominal) 30 = 3000 lumens (nominal) 40 = 4000 lumens (nominal)	D010 = 120-277VAC 50/60Hz 0-10V analog 1%-100% dimming DLV = Distributed Low Voltage driver, 1%-100% dimming DLV for use with Eaton's DLVP system only. Refer to DLVP low-voltage power module and DLVP specifications for details. ¹

Options	Accessories
REM7 = 7 watt emergency module with remote test / indicator light, use with D010 only ¹ REM14 = 14 watt emergency module with remote test / indicator light, use with D010 only ¹ REMV7 = 7 watt emergency module with remote test / indicator light, use with DLV only ^{1, 2} REMV14 = 14 watt emergency module with remote test / indicator light, use with DLV only ^{1, 2} IEM7 = integral 7 watt emergency module with integral test / indicator light, use with D010 only ¹ IEM14 = integral 14 watt emergency module with integral test / indicator light, use with D010 only ¹ IEMV7 = integral 7 watt emergency module with integral test / indicator light, use with DLV only ^{1, 2} IEMV14 = integral 14 watt emergency module with integral test / indicator light, use with DLV only ^{1, 2} LWTPD1 = factory installed LumaWatt Pro wireless tile mount sensor kit, use with D010 only ¹ SWPD1 = factory installed WaveLinX tile mount daylight sensor, includes control module, sensor, and cable, use with D010 only ¹	HB128APK = L channel hanger bar, 26", pair (replacement) RMB22 = Adjustable wood joist mounting bars, pair, extend to 22" long H347 = 347 to 120V step down transformer, 75VA H347200 = 347 to 120V step down transformer, 200VA PORLWTPD1 = LumaWatt Pro wireless sensor kit, field installed, use with D010 only ¹ TWSWPD1 = WaveLinX wireless sensor kit, field installed, use with D010 only ¹

LED Module	Lumens	CRI/CCT
HM4 = 4" LED module	12 =1000, 1500 and 2000 lumens (nominal), use with HC410*, HC415*, HC420* housings 34 =3000 and 4000 lumens (nominal), use with HC430*, HC440* housings	827 = 80 CRI (minimum), 2700K CCT 830 = 80 CRI (minimum), 3000K CCT 835 = 80 CRI (minimum), 3500K CCT 840 = 80 CRI (minimum), 4000K CCT 927 = 90 CRI (minimum), 2700K CCT 930 = 90 CRI (minimum), 3000K CCT 935 = 90 CRI (minimum), 3500K CCT 940 = 90 CRI (minimum), 4000K CCT

Reflector	Distribution ³	Finish	Flange	Accessories
41 = 4" conical reflector	ND = narrow 53° beam angle 0.84 SC (nominal) MD = medium 61° beam angle 1.00 SC (nominal) WD = wide 76° beam angle 1.24 SC (nominal) RWW = rotatable wall wash with linear spread lens	C = Specular clear H = Semi-specular clear W = White (white flange)	Blank = Polished flange standard with C & H reflectors Blank = White flange standard with W reflector WF = White flange option available with C & H reflectors	41RWWPK = rotatable wall wash insert for 4" reflector –replacement part kit

Baffle	Distribution ³	Finish	Flange	Accessories
41 = 4" baffle reflector	WD = wide 76° beam angle 1.24 SC (nominal) RWW = rotatable wall wash with linear spread lens	BB = Black baffle (white flange) WB = White baffle (white flange)	Blank = White flange standard with BB, & WB	41RWWPK = rotatable wall wash insert for 4" reflector –replacement part kit

IEM Reflector	Distribution ³	Finish	Flange	Integral Emergency
41 = 4" conical reflector for integral emergency only	ND = narrow 53° beam angle 0.84 SC (nominal) MD = medium 61° beam angle 1.00 SC (nominal) WD = wide 76° beam angle 1.24 SC (nominal)	C = Specular clear H = Semi-specular clear W = White (white flange)	Blank = Polished flange standard with C & H reflectors Blank = White flange standard with W reflector WF = White flange option available with C & H reflectors	IEM = Reflector for integral emergency only

IEM Baffle	Distribution ³	Finish	Flange	Integral Emergency
41 = 4" baffle reflector for integral emergency only	WD = wide 76° beam angle 1.24 SC (nominal)	BB = Black baffle (white flange) WB = White baffle (white flange)	Blank = White flange standard with BB, & WB	IEM = Reflector for integral emergency only

Reflector	Distribution ³	Finish	Flange
41PS = 4" non-conductive polymer 'dead front' conical reflector ⁴	MD = medium 61° beam angle 1.00 SC (nominal)	W = White (white flange)	Blank = White flange standard with W reflector

Notes:

- Not available with CP version
- ULus for U.S. only
- Values are nominal for white reflector, others may vary.
- 41PS reflector only available in NON-IC environments and up to 3000 lumens.

PHOTOMETRY

NARROW DISTRIBUTION - SPECULAR CLEAR FINISH, 2000 LUMEN MODEL, 80 CRI, 3500K

NARROW (45° BEAM*)		CANDLEPOWER DISTRIBUTION		CONE OF LIGHT				CANDELA TABLE		ZONAL LUMEN SUMMARY			LUMINANCE	
Test Number	P255618							Degrees Vertical	Candela	Zone	Lumens	% Fixture	Average Candela Degrees	Average 0° Luminance
Housing	HC420D010							0	2112	0-30	1219	73.1	45	15974
Module	HM412835							5	2079	0-40	1553	93.1		
Reflector	41NDC							15	1784	0-60	1666	99.9		
Lumens	1667 Lm							25	1157	0-90	1667	100		
Efficacy	83.4 Lm/W	35	534	90-180	0	0								
SC	0.82	45	116	0-180	1667	100	85	0						
UGR	12.2	55	13											
		65	0											
		75	0											
		85	0											
		90	0											
				MH	FC	L	W							
				5.5'	69.8	4.4	4.4							
				7'	43.1	5.6	5.6							
				8'	33	6.4	6.4							
				9'	26.1	7.2	7.2							
				10'	21.1	8.2	8.2							
				12'	14.7	9.8	9.8							

MEDIUM DISTRIBUTION - SPECULAR CLEAR FINISH, 2000 LUMEN MODEL, 80 CRI, 3500K

MEDIUM (55° BEAM*)		CANDLEPOWER DISTRIBUTION		CONE OF LIGHT				CANDELA TABLE		ZONAL LUMEN SUMMARY			LUMINANCE	
Test Number	P255818							Degrees Vertical	Candela	Zone	Lumens	% Fixture	Average Candela Degrees	Average 0° Luminance
Housing	HC420D010							0	1761	0-30	1209	67.4	45	22576
Module	HM412835							5	1764	0-40	1615	90.1		
Reflector	41MDC							15	1686	0-60	1784	99.5		
Lumens	1793 Lm							25	1257	0-90	1793	100		
Efficacy	89.7 Lm/W	35	655	90-180	0	0								
SC	0.97	45	164	0-180	1793	100	85	0						
UGR	13.6	55	28											
		65	8											
		75	2											
		85	0											
		90	0											
				MH	FC	L	W							
				5.5'	58.2	5.2	5.2							
				7'	35.9	6.6	6.6							
				8'	27.5	7.6	7.6							
				9'	21.7	8.6	8.6							
				10'	17.6	9.6	9.6							
				12'	12.2	11.6	11.6							

WIDE DISTRIBUTION - SPECULAR CLEAR FINISH, 2000 LUMEN MODEL, 80 CRI, 3500K

WIDE (65° BEAM*)		CANDLEPOWER DISTRIBUTION		CONE OF LIGHT				CANDELA TABLE		ZONAL LUMEN SUMMARY			LUMINANCE	
Test Number	P256018							Degrees Vertical	Candela	Zone	Lumens	% Fixture	Average Candela Degrees	Average 0° Luminance
Housing	HC420D010							0	1257	0-30	1054	55.8	45	43057
Module	HM412835							5	1265	0-40	1571	83.2		
Reflector	41WDC							15	1295	0-60	1871	99.1		
Lumens	1889 Lm							25	1247	0-90	1889	100		
Efficacy	94.4 Lm/W	35	841	90-180	0	0								
SC	1.23	45	312	0-180	1889	100	85	0						
UGR	15.7	55	50											
		65	13											
		75	5											
		85	0											
		90	0											
				MH	FC	L	W							
				5.5'	41.6	6.6	6.6							
				7'	25.7	8.6	8.6							
				8'	19.7	9.8	9.8							
				9'	15.5	11	11							
				10'	12.6	12.2	12.2							
				12'	8.7	14.6	14.6							

*Value are nominal for specular clear reflectors, others may vary.
SC = Spacing Criteria
UGR = Unified Glare Rating

Photometric Multipliers (nominal lumen values)

1000 Lumen	1500 Lumen	2000 Lumen	3000 Lumen	4000 Lumen
0.53	0.72	1.00	1.38	1.87

Multipliers for relative lumen values with other series models.

CCT Multipliers – 80CRI

2700K	3000K	3500K	4000K
0.91	0.94	1.00	1.01

Multipliers for relative lumen values with other series color temperatures.

Color Finish Multipliers

Finish code	C	H	W/WB	BB
Finish	Specular Clear	Semi-Specular	Matte White White Baffle	Black Baffle
Multiplier	1.00	0.95	0.97	0.82

Multipliers for relative lumen values with other color finishes.

CCT Multipliers – 90CRI

2700K	3000K	3500K	4000K
0.75	0.82	0.89	0.89

Multipliers for relative lumen values with other series color temperatures.

PHOTOMETRY

WALL WASH DISTRIBUTION - SPECULAR CLEAR FINISH, 2000 LUMEN MODEL, 80 CRI, 3500K

WALL WASH	
Test Number	P256338
Housing	HC420D010
Module	HM412835
Reflector	41RWWC
Lumens	1816 Lm
Efficacy	90.8 Lm/W
SC	1.20

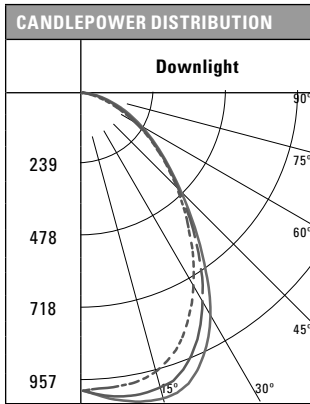

CANDELA TABLE	
Degrees Vertical	Candela
0	901
5	929
15	957
25	871
35	647
45	420
55	267
65	156
75	70
85	8
90	0

ZONAL LUMEN SUMMARY		
Zone	Lumens	% Fixture
0-30	700	38.5
0-40	1078	59.3
0-60	1630	89.8
0-90	1816	100
90-180	0	0
0-180	1816	100

LUMINANCE	
Average Candela Degrees	Average 0° Luminance
45	57956
55	45350
65	35998
75	26547
85	8498

SC = Spacing Criteria, nominal for specular clear reflector, others may vary.

SINGLE UNIT FOOTCANDLES							
2.5' from wall (distance from fixture along wall)							
1	9.4	6.9	3.2	1.1	0.3	0.1	0
2	12.4	9.5	5.2	2.4	0.9	0.3	0.1
3	13.7	11.1	5.9	2.5	1.1	0.4	0.2
4	10.7	9.4	6.1	3	1.2	0.5	0.2
5	7.7	7	5.4	3.1	1.5	0.6	0.2
6	5.5	5.2	4.3	3	1.6	0.8	0.3
7	4	3.9	3.4	2.6	1.6	0.9	0.4
8	3	2.9	2.6	2.1	1.5	0.9	0.5
9	2.3	2.2	2.1	1.8	1.4	1	0.6
10	1.8	1.8	1.6	1.4	1.2	0.9	0.6

MULTIPLE UNIT FOOTCANDLES						
2.5' from wall (distance from fixture along wall)			2.5' from wall (distance from fixture along wall)			
1	10.5	9.8	10.5	10.5	9.8	10.5
2	14.8	14.5	14.8	14.8	14.5	14.8
3	16.2	17	16.2	16.2	17	16.2
4	13.7	15.8	13.7	13.7	15.8	13.7
5	10.8	12.6	10.8	10.8	12.6	10.8
6	8.5	9.6	8.5	8.5	9.6	8.5
7	6.6	7.3	6.6	6.6	7.3	6.6
8	5.2	5.6	5.2	5.2	5.6	5.2
9	4.1	4.4	4.1	4.1	4.4	4.1
10	3.2	3.4	3.2	3.2	3.4	3.2

Photometric Multipliers (nominal lumen values)

1000 Lumen	1500 Lumen	2000 Lumen	3000 Lumen	4000 Lumen
0.53	0.72	1.00	1.38	1.87

Multipliers for relative lumen values with other series models.

Color Finish Multipliers

Finish code	C	H	W/WB	BB
Finish	Specular Clear	Semi-Specular	Matte White White Baffle	Black Baffle
Multiplier	1.00	0.95	0.97	0.82

Multipliers for relative lumen values with other color finishes.

CCT Multipliers – 80CRI

2700K	3000K	3500K	4000K
0.91	0.94	1.00	1.01

Multipliers for relative lumen values with other series color temperatures.

CCT Multipliers – 90CRI

2700K	3000K	3500K	4000K
0.75	0.82	0.89	0.89

Multipliers for relative lumen values with other series color temperatures.



WHY JUST BE GREEN WHEN YOU CAN BE COLORFUL?

The FBT RGB Series combines state of the art technology with a flexible, durable housing to create an extremely bright, uniform illumination with a versatility that makes it perfect for any custom design application.

This RGB flexible border tube is equipped with tri-chip LEDs composed of red, green and blue colors that can be controlled by a DMX controller to offer several different color shades and effects.

FEATURES

- RGB border tubing utilizing tri-chip SMD5050 LEDs as its light source
- Energy efficient LEDs consumes 3.7W/ft , saving up to 70% or more over traditional neon
- Indoor and outdoor rated
- Flexible PVC housing conforms to almost any angle, virtually unbreakable
- Dome surface, continuous glow with invisible light points, high brightness and an even mixture of color
- Continuous runs up to 65' when power is supplied at both ends
- Easy to install using either aluminum mounting clips or 3' extruded aluminum mounting channels
- Meets or exceeds UL2108 standards for low voltage lighting systems
- 3 year warranty

TECHNICAL SPECIFICATION

- 4 wire, color changing RGB, flexible border tubing
- Voltage: 24VDC
- Frequency: 60Hz
- IP rating: IP68
- Dimensions: 0.45" wide, 1.14" high
- Operating distance: 65' (when power is supplied at both ends)
- Beam angle: 160°

PRODUCT SPECIFICATIONS

- LED specs:
 - Rated life: 50,000 hours
 - SMD5050 tri-chip color LEDs
 - 18 LEDs per foot
 - 0.657" distance between LEDs
- Construction: Flexible, shatterproof, cool to touch, UV inhibited, PVC housing
- Roll length: 65'
- Mounting: 2" mounting clips (FBT-RGB-MC) or mounting channels available in standard (FBT-RGB-LCH), or in a locking version (FBT-RGB-LCH-L)
- Control: Can be controlled via a DMX controller
- Operating temperature: 32°F - 113°F (0°C - 45°C)
- Storage temperature: -4°F - 113°F (-20°C - 45°C)
- 3 year warranty, does not apply to damages caused by improper installation, abuse, fire or acts of God

Model: _____ Date: _____
 Accessories: _____
 Job Name: _____ Type: _____

FBT RGB

RGB LED FLEXIBLE BORDER TUBE

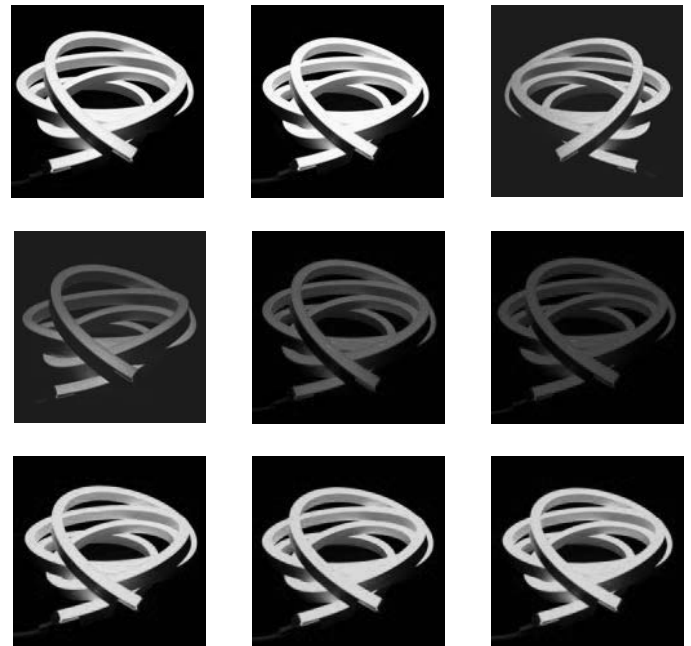
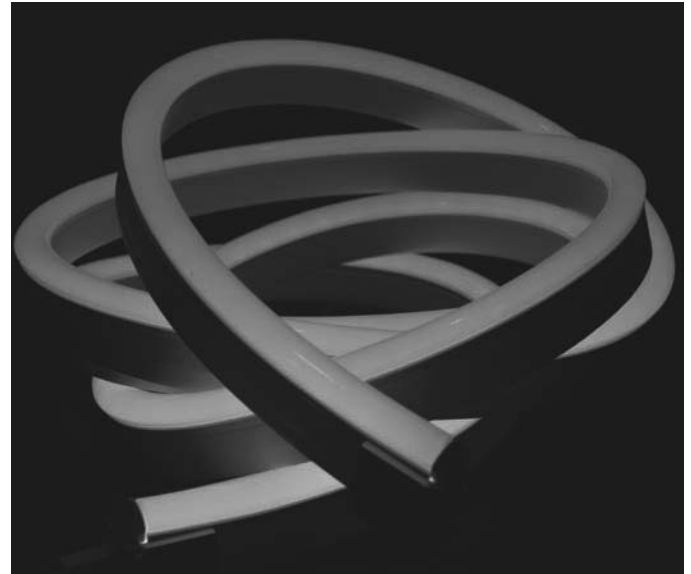

For the complete line of specialtyLED® products, visit us online at barronltg.com.

SPECIFICATIONS ARE SUBJECT TO CHANGE WITHOUT NOTICE

TECHNICAL INFORMATION

Color	Voltage	Rated Power W/ft	MIN cutting increment	Max Run*
RGB Color Changing	24VDC	3.7	4"	65'

* When unit has power supplied to both ends

RGB ILLUMINATION INFORMATION

Color	Wavelength nm	Lumens lm/ft
Red	620	7
Green	520	27
Blue	460	5
White (All Colors Combined)	n/a	40

CANDLE POWER DISTRIBUTION

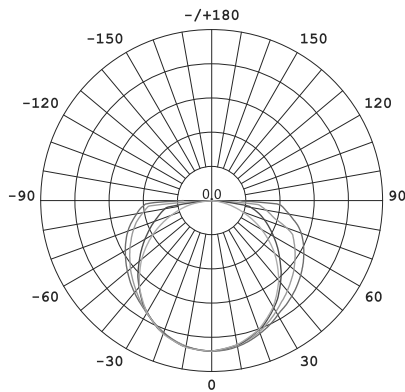

ILLUMINANCE CHARACTERISTICS

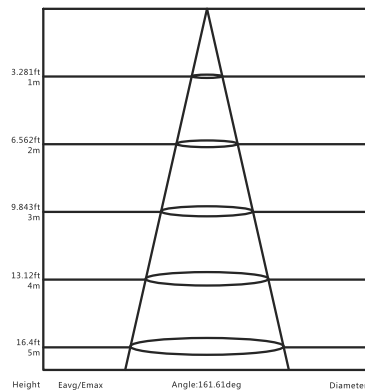

DIMENSIONS

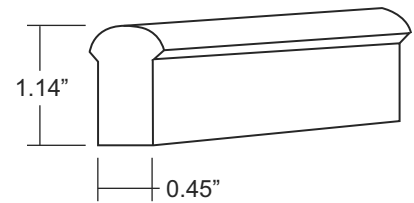

ORDERING INFORMATION

Example: FBT-RGB-65-24V

Series	Length	Voltage ²
FBT-RGB	65 = 65 Feet	24V = 24 Volt DC
	XX ¹ = Custom Length	

Notes

¹ Custom lengths ordered specific to product cutting increments

² Requires transformer, ordered separately

24VDC NON-DIMMING TRANSFORMER ORDERING INFORMATION (ORDER AS SEPARATE LINE ITEM)





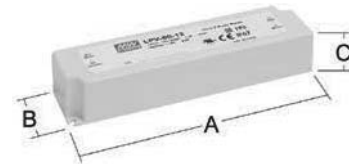





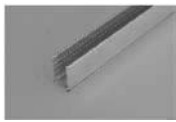

Example: XFMR-24-60

Part Number	Description	Dimensions (AxBxC)
XFMR-24-20	24 Volt, 20 Watt, Class 2 Power Supply	4.65" x 1.37" x 1.0"
XFMR-24-35	24 Volt, 35 Watt, Class 2 Power Supply	5.8" x 1.57" x 1.18"
XFMR-24-60	24 Volt, 60 Watt, Class 2 Power Supply	6.39" x 1.67" x 1.25"
XFMR-24-150	24 Volt, 150 Watt, Class 2 Power Supply	8.74" x 2.67" x 1.52"

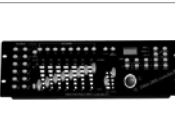

Note: All transformers are to be installed per NEC requirements. Wire leads on the 24 volt product are 18 gauge. Transformer is to be mounted within 10 feet of product. If transformer is mounted more than 10 feet from product, voltage drop and maximum operating distances should be taken into account when making transformer selection.

ACCESSORIES (ORDER AS SEPARATE LINE ITEM)

Part Number	Description	Part Number	Description
FBT-RGB-LCH	 Linear Channel (3.2' L x 13/16" H x 1 1/16" W)	FBT-RGB-SP	 Seamless splicing/middle connector. (Ideally used with the gripper tool)
FBT-RGB-LCH-L	 Locking Linear Channel	FBT24V-GR	 Gripper tool allows a seamless and weather tight connection when using the middle connector
FBT-RGB-MC	 2" Mounting Clip	RFX-RGB-DMX-CV-DECODER	 Indoor 5050 RGB DMX Decoder with RJ45 input, output 12-24V (needs DMX board, not included) INDOOR USE ONLY
FBT-RGB-LC-RIGHT-24V	 Line Cord connector assembly right power feed	RFX-4B-3CH-RGB	 DMX controller for sample purposes INDOOR USE ONLY
FBT-RGB-LC-LEFT-24V	 Line Cord connector assembly left power feed	RFX-RGB-SRC-174	 DMX controller, 192 channels INDOOR USE ONLY
FBT-RGB-EC	 End Cap connector assembly	NICOLAUDIE-STICK-KE-1	 DMX controller, 1024 channels. INDOOR use only (requires the use of the NICOLAUDIE-POWER4M power adapter)
FBT-RGB-SJ	 1.5" Jumper Cable from one end of the flex to another	NICOLAUDIE-POWER4M	 6VDC, 0.65A power adapter for NICOLAUDIE-STICK-KE-1

TYPICAL ACCESSORIES FOR 24V INSTALLATION

- FBT-RGB Flexible Border Tube (FBT-RGB-26-24V)
- Linear Channel (FBT-RGB-LCH) AND/OR Mounting Clips (FBT-RGB-MC)
- End cap connector assembly (FBT-RGB-EC)
- Line Cord (FBT-RGB-LC-RIGHT-24V)
- Transformer (XFMR-24-150)
- Decoder (RFX-RGB-DMX-CV-DECODER)
- DMX controller (NICOLAUDIE-STICK-KE-1)
- Power adapter for DMX controller (NICOLAUDIE-POWER4M)

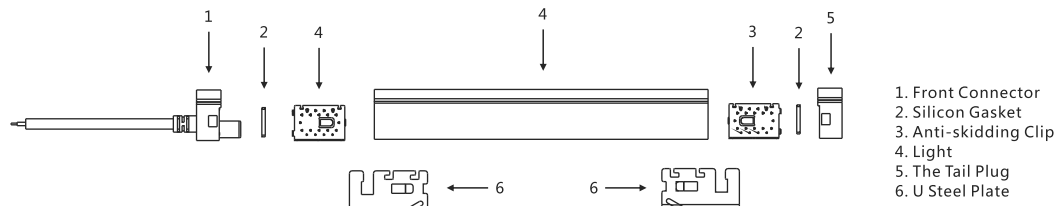

MF-LC includes part 1, 2, 4 and 6
MF-EC includes part 2, 3, 5 and 6





For the complete line of specialtyLED® products, visit us online at barronltg.com or call 800.533.3948.

Model: _____ Date: _____
 Accessories: _____
 Job Name: _____ Type: _____

NICOLAUDIE-STICK-KE-1

1024 CHANNEL DMX TOUCH SCREEN CONTROLLER

This complete stand alone wall-mounted DMX controller is perfect for all your lighting control expectations. Along with its sleek design, the product comes with great features such as 1024 DMX channels, touch sensitive panel, clock/calendar, remote control, Ethernet facilities and unlimited memory via a micro SD card.

The Stick KE-1 lighting controller provides an intuitive interface to easily and comfortably modify lighting effects. It has an on/off button at the top, 8 buttons to choose lighting effects, 2 buttons to cycle between pages, and a horizontal fader to instantly adjust dimmer, speed and color – making it simple to take control of all your lighting.

The STICK supports up to 5 areas across 25 pages. This allows you to split up a room or a building and play up to 5 different scenes simultaneously. For example, you could have:

- Area A: Control over the ambient lighting of a room, such as some single channel halogens
- Area B: A subtle color changing effect playing on LED bars in the ceiling
- Area C: Some static colors used on floor lighting
- Area D: Control of the wall lighting
- Area E: A global override which controls everything

The STICK-KE1 includes an Ethernet network connector allowing you to connect this controller to a Local Area Network (LAN). Once connected, the unit can be controlled from the STICK REMOTE or EASY REMOTE app for Apple iOS and Google Android devices. Remote control applications are also available for PC, MAC and Linux and can be downloaded from www.lightingsoft.com

FEATURES

- Controls RGB lights with DMX512 lighting protocol
- Flat wall mounted lighting controller
- Universal mounting plate compatible with any electrical back box
- Mini-USB connection for software programming
- Can be used without a computer in standalone mode
- Touch sensitive control panel
- 2 DMX universes (1024 channels)
- Can control up to 200 scenes, up to 5 different zones
- Unlimited memory via Micro SD card
- Integrated clock/calendar
- RS 232 serial and I/O ports
- Optional ethernet card
- Indoor use only

DMX PACKAGE CONTAINS;

- Standalone wall mounted controller
- User manual
- Mini-USB cable
- Micro SD card and adapter
- **6V DC power adapter supplied separately**
(Part number NICOLAUDIE-POWER4M)



Mini USB Connector (Included)

NICOLAUDIE STICK-KE-1

ORDERING INFORMATION

Example: NICOLAUDIE-STICK-KE-1

SKU ¹	Description
NICOLAUDIE-STICK-KE-1	DMX Touch Screen Controller (Supplied with black finish)
NICOLAUDIE-POWER4M ²	5.8W Power Supply for STICK-KE-1 (Required for KE-1)

Notes

¹ Standard unit supplied with black frame

² Power supply ordered separately Part Number: NICOLAUDIE-POWER4M

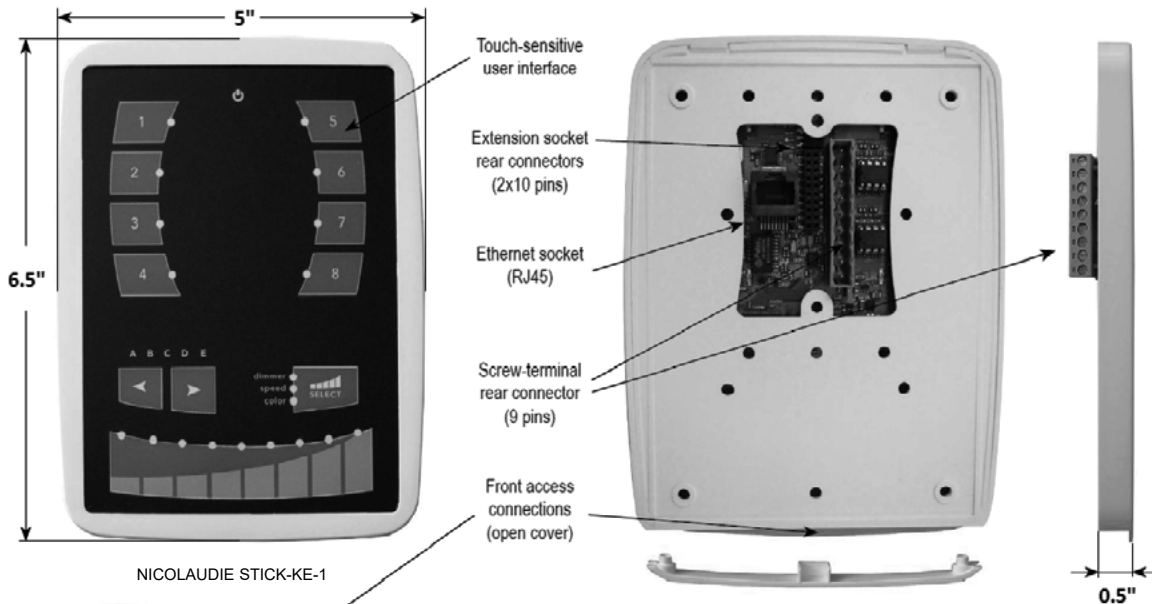

NICOLAUDIE STICK-KE-1

Package	Interface, sdcard, datasheet, cdrom, usb cable		
Software	ESA + ESA PRO on PC/Windows, ESA2 on PC + MAC		
Application	ARCOLIS + STICK REMOTE on iPhone/iPad/Android		
Available colors	Frame (black or white)		
Options	Power supply (*)		
Standards	EC, EMC, ROHS, ETL, UL (some are in process)		
Image size	Standard 5.9" x 4.3" image		
Temperature	14°F to 122°F		-10°C to 50°C
Dimensions	6.5"x5"x0.5" 168x128x11.5 mm	Complete package	9.8"x5.9"x2.16" 250x150x55 mm
Weight	0.44lbs/0.2kg	Complete package	1.32lbs/0.6kg

SPECIFICATIONS / CONNECTIONS		Built-in features	screw-terminal rear connector (9 pins)	extension socket rear connectors (2x10 pins)	front access connections (open cover)
Power Supply	9V DC 0.65A, supplied		•		USB
DMX Output #1	First universe, 512 channels DMX512 output		•	•	
DMX Output #2	Second universe, 512 channels DMX512 output (*)			•	
USB	USB 2.0 communication for PC/software				•
Ethernet	Advanced networking features	•			
Ports 1,2,3,4	4 Contact closure inputs, connect to ground for operating		•	•	
Ports 5,6,7,8	4 Contact closure inputs, connect to ground for operating			•	
User interface	14 buttons, 1 fader, 28 leds (Touch-sensitive keypad)	•			power/data leds
SDCARD	Micro sd card for stand alone memory use (supplied)				•
RESET	Push button for reset operation				•
RS232	RS232 Serial communication for external synchronisation			•	
Output relay	Automatic Stand by 5V signal			•	
Clock	Real time clock and calendar	•			
Infrared receiver	Easy learning triggering from any 36Khz remote control	•			

NICOLAUDIE-POWER4M

5.8W, 0.65A POWER ADAPTER NICOLAUDIE DMX CONTROLLER

5.8W power supply required for the use of the NICOLAUDIE-STICK-KE-1 controller. **(REQUIRED)**
For indoor dry location use only.

Input Voltage:	100-240VAC
Frequency:	50/60 Hz
Output Power:	5.85W
Output Voltage:	3V - 24V
Over Voltage Protection:	120%min
Over Current Protection:	120%min
Short Protection:	Auto Recovery
Load Regulation:	±5%

GENERAL SPECIFICATIONS

Operating Temperature:	0 ~ 40°
Storage Temperature:	-20 ~ 85°
Operating Relative Humidity:	5 ~ 95% RH
Withstanding Voltage:	3000VAC (Min), 5mA (Max)
Insulation Resistance:	500VDC 100MΩ(Min)
Dimensions:	68.5 × 50 × 26.5mm



NICOLAUDIE POWER4M

INSTALLATION

Simply screw the STICK's back plate onto a single or double gang wall socket, connect the power and DMX cables to the STICK's block connector, then clip the STICK onto the wall. This unit is for indoor dry location use only.



1. MOUNT AN ELECTRICAL BOX INSIDE THE WALL

The controller can be installed in any standard electrical backbox. If you use a double size box, you can insert the power supply inside.

PORT 1,2,3,4: If your application needs to have some external contact closures, make the contacts between the ground and the ports.

2. CONNECT THE WIRES

DMX: Connect the DMX cable to the lighting receivers (LEDs, dimmers, fixtures, etc.)
(For XLR: 1 = Ground, 2 = DMX, 3 = DMX+)

POWER: Connect a 9V DC 0.65A
Be sure not to invert the + and the ground



3. MOUNT THE INTERFACE ON THE WALL

A. Mount the back side of the interface on the wall with 2 or more screws

B. Plug in the 2 connectors (see blue arrow)

C. Close the interface using 1 screw

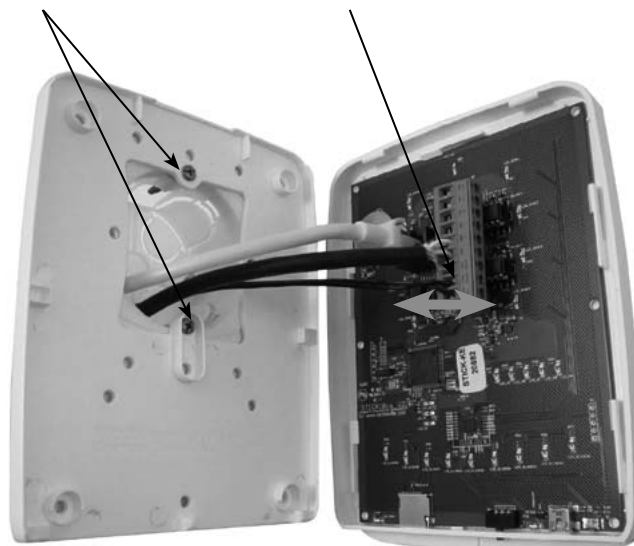

EXT Port Connector Pin Detail

RS232 TX	→ 1	2 ←	GND_DMX
RS232 RX	→ 3	4 ←	DMX1 -
PORT 7	→ 5	6 ←	DMX1 +
PORT 6	→ 7	8 ←	DMX2 -
PORT 5	→ 9	10 ←	DMX2 +
PORT 4	→ 11	12 ←	RELAY
PORT 3	→ 13	14 ←	3.3V
PORT 2	→ 15	16 ←	IR_RX
PORT 1	→ 17	18 ←	GND
PORT 0	→ 19	20 ←	VIN

PORTS 1 to 8 make contacts between G (GND) and P1..P8

BLACKOUT relay (energy save) using the 2 pins : BK and G (GND)

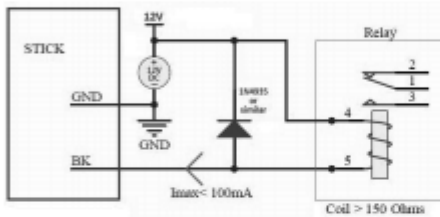

2x10 pins EXTENSION connector

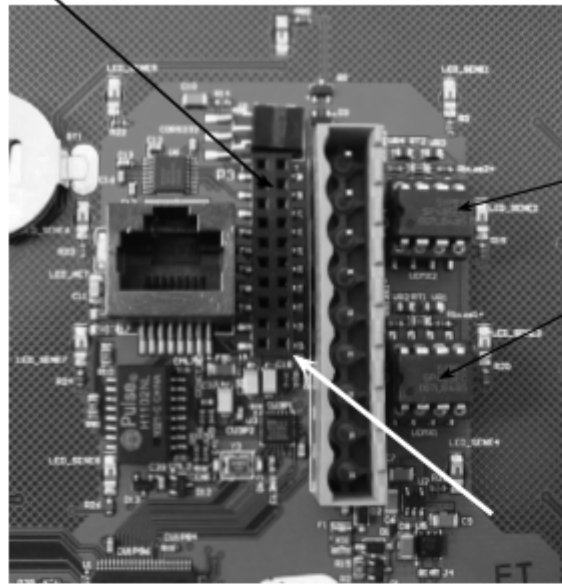

You can easily replace DMX CHIPS

DMX universe #2

DMX universe #1

Ref:
SP485ECP-L
MAX485CPA+

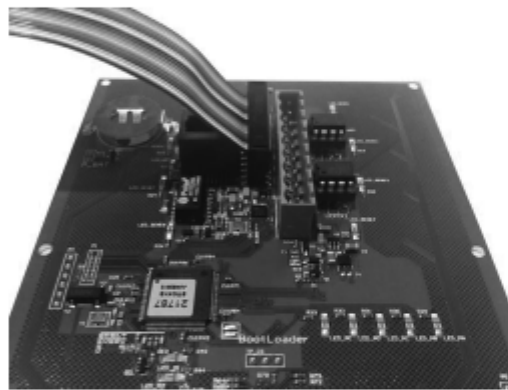

Wire Color Code for Lumentouch EXT Port Connector
NOTE: connector should be installed with ribbon facing Ethernet port

Pin	Color	Port
P1	Black1	RS232 TX
P2	White1	DMX GND
P3	Grey1	RS232 RX
P4	Purple1	DMX U1 (-)
P5	Blue1	Port7
P6	Green1	DMX U1 (+)
P7	Yellow1	Port6
P8	Orange1	DMX U2 (-)
P9	Red1	Port5
P10	Brown1	DMX U2 (+)
P11	Black2	Port4
P12	White2	Relay
P13	Grey2	Port3
P14	Purple2	3.3V
P15	Blue2	Port2
P16	Green2	IR RX
P17	Yellow2	Port1
P18	Orange2	GND
P19	Red2	Port0
P20	Brown2	VIN

RS232 TRIGGERING

- Make a cable using the 3 pins: TX, RX and G (GND)
- Set the RS232 parameters to: 9600bds 8 bits, no Parity, 2 Stop bits
 - To play a scene, send 3 bytes: 1 x 255 (x = scene number)
 - To stop a scene, send 3 bytes: 2 x 255 (x = scene number)
 - To pause a scene, send 3 bytes: 3 x 255 (x = scene number)
 - To release a pause, send 3 bytes: 4 x 255 (x = scene number)
 - To reset a scene, send 3 bytes: 5 x 255 (x = scene number)

Note: The scene number (x) can be from 1 to 40. For instance, 11 means Page B Scene #3

NOTES

- RS232 triggering is only for selecting / playing scenes on the LTO
- The scenes you want to select / play must be programmed to the buttons on the LTO
- The RS232 triggering must be enabled / checked ON in LTPO Hardware Tools, under Parameters
- The RS232 connections must be landed on the LTO, via the COM Plus or External LTO Connector
- The TX and RX must be crossed over, aka TX to RX and RX to TX, Ground still goes to Ground
- All command strings must be sent as HEX values
- Com settings are 9600 baud, 8 bit, 2 stop bits, no parity, no hardware flow

SOFTWARE AND LINKS

ARCOLIS software (iPhone/iPad)

<http://itunes.apple.com/en/app/arcolis/id495161115?mt=8>

ARCOLIS software (Android)

<https://play.google.com/store/search?q=arcolis>

ESA, ESAPRO software (Windows)

www.nicolaudie.com (-> Support -> Downloads)

ESA2 software (Windows, Mac)

www.nicolaudie.com (-> Support -> Downloads)

ESA, ESAPRO manuals

www.nicolaudie.com/manuals.php

STICK REMOTE

www.lightingsoft.com

REMOTE APPLICATION FOR IPHONE/IPAD, ANDROID, WINDOWS

Driver, Firmware, Tools

www.nicolaudie.com/hardware.php

STICK Forum

www.nicolaudie.com/forum_support

STICK design configurator

www.nicolaudie.com/stick_config





FCC600
Series

Exterior LED Cylinder Lighting To The Next Level

Design & Construction: FC Lighting has developed the latest durable, high output exterior cylinder line on the market. Engineered with a revolutionary heat dissipation component, these fixtures come available with style, optics choices, mounting options and accessories that create limitless possibilities for any lighting specifier's dream application. These Cylinders provide an unmatched flexibility for specifying powerful lighting with an equally sophisticated style.

Style & Accessories: Add to your dream specification with an *Angle Cut Visor* or *Up / Down Lighting* solution. With design flexibility only limited by the imagination, specifiers can create an environment with contemporary style and mood enhancing control features that complement any application. *FCC Series Cylinders* come in 4", 6", 8" and 10" diameters that are available from 10" up to 20" long.

Output and Optics Flexibility: American engineered performance features create high lumen output with a high efficacy. The engineers at FC Lighting have designed optics options that hand over control of beam and field angle effects. *FCC Series Cylinders* are the ultimate solution that allow designers the ability to customize lighting for their clients specific needs.

Power Dimming & EMR Flexibility: The latest development in the *FCC Series Cylinder* line created the widest variety of integral power, dimming and control solutions possible. EMR and wireless controls all compatible with Dali, DMX, ELV and 0-10% dimming protocols. Lutron Ecosystem® compatibility and eLdoLED drivers are also available. *FCC Series Cylinders* are the most comprehensive cylinder lighting solutions available on the market today!

DELIVERING UP TO 5000 LUMENS!





FCC600 Series



Date:		Approved:
Type:		
Fixture:		
Project:		

FCC600 Series Cylinders are the most versatile high output exterior cylinders in the market. These Cylinders are designed with outdoor applications in mind. Dry, damp or wet conditions and developed with the highest variety of mounting capabilities, power and output levels, optical distributions, and many featured options.

SPECIFICATIONS

PHYSICAL	
beam spread	12° 15° 25° 35° 40° 60° 72° 90°
diameter/height	diameter: 6.31" height: 10.86" 14.86" 22.86"
weight	8 lb
housing	heavy-walled, extruded aluminum housing with die-cast lens ring and cap with stainless steel hardware
lens	IK05 impact compliant, clear anti-glare tempered glass
mounting	mounts directly to standard recessed junction box additional holes allow unit to be attached directly to mounting surface
ingress protection	continuous silicone gasket to seal out contaminants, IP65 rated for dry, damp or wet locations
vibration resistance	compliant with 1G ANSI C136.31, Seismic rated AC-156
finish	7-stage chemical stage pre-treatment process that includes iron phosphate, to prepare the substrate for a UV stable, super durable standard polyester powder coat

PERFORMANCE	
color temperature	2700K 3000K 3500K 4000K 5700K
delivered lumens	5000 Lm max - Selectable in 500 Lm increments 3000 Lm max for BBU (integral)
lifetime	> 70,000 hours / L70 or better
color consistency	2-step MacAdam Ellipse 83 CRI standard optional 93 and 97 CRI
temperature	operating: -4°F to 104°F (-20°C to 40°C) start up: -4°F to 104°F (-20°C to 40°C) storage: -40°F to 176°F (-40°C to 80°C)
warranty	5 year limited warranty (refer to website for details)

NON-LED	
CFL	13Q, 18T, 26T socket: PL: four pin plug-in type compact fluorescent lamp holder (lamp by others)
ballast	fluorescent electronic, UL listed ballast standard
HID	20W MH G12, 30W MH G12 socket: G12 base porcelain socket (lamp by others)
ballast	electronic ballast standard: ballast has a manufacturer issued 5 year warranty

ELECTRICAL	
input voltage	Universal 120–277V AC standard 347V optional
power supply	integral Class II, electronic high-power factor > 94% EldoLED & Lutron optional
certification	CEC Title 24 - JA8 Compliant
standards	ETL / cETL or CE, tested to UL 1598 and UL 8750 standards / UL-Class I / IES LM-79 / LM-80 / FCC Part 15
power consumption	up to 60W max @ 120V
dimming interface	standard: LED dimming: 0-10V, 1%
	optional: ELV TRIAC dim to off DMX DALI

Expanded Disclaimer: Due to continuous development and improvements, specifications are subject to change without notice. FC Lighting and Solid State Luminaires reserves the right to change lab test details or specifications without notice. Product use certifies agreement to FC Lighting terms and conditions. FCC Series Cylinders are engineered and produced in our Illinois manufacturing facility.



a US Commercial Lighting Manufacturer Since 1982

Specification Sheet

RP Rev. 11/19/2018

FCC600 Series

ORDERING INFORMATION

FCC600																		
model	height	mounting		voltage		source CCT			CRI	lumen output		finish	optics					
FCC600	Ø6"	10	SF	Surface	UNV	120V-277V	LED	27K	2700K	CR83	83 CRI	5L	500 Lm	BK	black	12	12° Narrow Spot (<i>deep optic</i>)	
		12	WM	Wall	347V	347V		3K	3000K	CR93	93 CRI	10L	1000 Lm	BZ	bronze	15	15° Spot (<i>deep optic</i>)	
		14	PD	Pendant				35K	3500K (no 97 CRI)	CR97	97 CRI	15L	1500 Lm	WH	white	25	25° Mid-Spot	
		16	CM	Cord				4K	4000K			20L	2000 Lm	SL	silver	40	40° Narrow Flood (<i>deep optic</i>)	
		18	SM	Slope				57K	5700K (no 97 CRI)			25L	2500 Lm	CC	custom color	50	50° Flood	
		20						R	Red			30L	3000 Lm			72	72° Wide Flood (<i>deep optic</i>)	
								G	Green			35L	3500 Lm			90	90° Flat	
								B	Blue			40L	4000 Lm					
								No CRI, lumen or optics apply on Non-LED source options - - chosen from table below					45L	4500 Lm				
													50L	5000 Lm				

deep optics only interchangeable with other deep optics noted in list above

Standard Driver Included: LED dimming: 0-10V, 1%

Driver Options (all drivers are 120V-277V unless otherwise specified)

MATCH SELECTION FROM CCT COLUMN ABOVE TO ONE CHOICE OF DRIVER FROM TABLE BELOW - review Driver Table on Pg 11 for driver specifications

STANDARD CCT (UNV) DRIVER OPTIONS	LUTRON DRIVER OPTIONS	eldoLED DRIVER OPTIONS	STANDARD CCT (347V) DRIVER OPTIONS
ET ELV or TRIAC	L2 Lutron 1%, 2-Wire, Forward Phase	E1 eldoLED 0-10V, Dim-to-Off	P3 347V 0-10V, Dim to 10%
LD 0-10V Dimming (1%)	L5 Lutron Ecosystem, 0.1%, Soft-on, Dim-to-Off	E2 eldoLED DALI, Dim-to-Off	
DMX DMX Dim to 0.1%,		E5 eldoLED 0-10, Dim to 1%	
DL DALI Dim to 0.1%,		E6 eldoLED DALI, Dim to 1%	
		E7 eldoLED DMX, Dim-to-Off	

Options (choose one per fixture)	
SF Soft Field (solite)	EM1 1500Lm : 15W (integral)
CPLX Custom Length Pendant (X=inches)	EM2 3000Lm : 30W (integral)
CBLX Custom Length Cable (X=inches)	EMR1 1500Lm : 15W (remote)
OPC Opal Polycarbonate Lens	EMR2 3000Lm : 30W (remote)
CV Cut-Off Visor	

PHYSICAL

DIMENSIONS

diameter/height	diameter: 6.3" height: 6" 8" 10" 12" 14" 16" 18" 20"
weight	5-10 lb (length dependent)

mounting	twist-lock surface mount twist-lock pendant wall mount slope mount twist-lock cord surface mount conduit adapter yoke
-----------------	---

PRODUCT DIMENSIONS

diameter	Ø 6.31"
height	10.86" 14.86" 22.86"

CUT OFF VISOR

CV - cut-off visor	5" D
total fixture height	H + 5" D

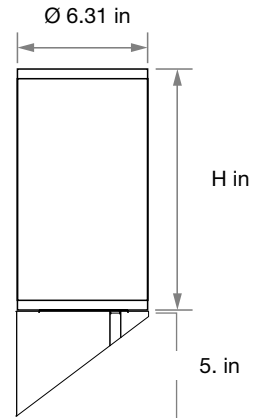
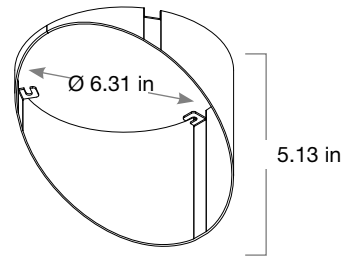
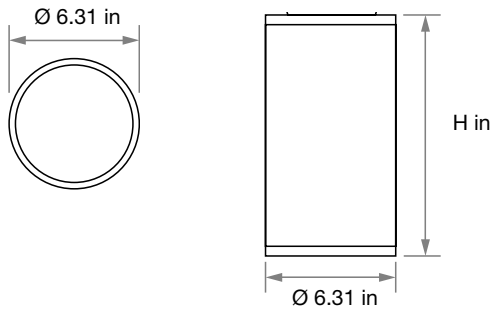

CONSTRUCTION & FINISH

housing	no visible seams or fasteners, marine grade, corrosion resistant, solid aluminum extrusion, die-cast aluminum components
lens	IK05 impact compliant, clear anti-glare tempered glass
finish	7-stage UV stable polyester powder coat



MOUNTING OPTIONS

SURFACE MOUNT		PENDANT MOUNT		WALL MOUNT	
SF - surface mount	4.25" W	PD - pendant mount	18"	WM - wall mount	2.05" D
add to fixture height	1.4"	add to fixture height	18"	total fixture depth	8.36" D

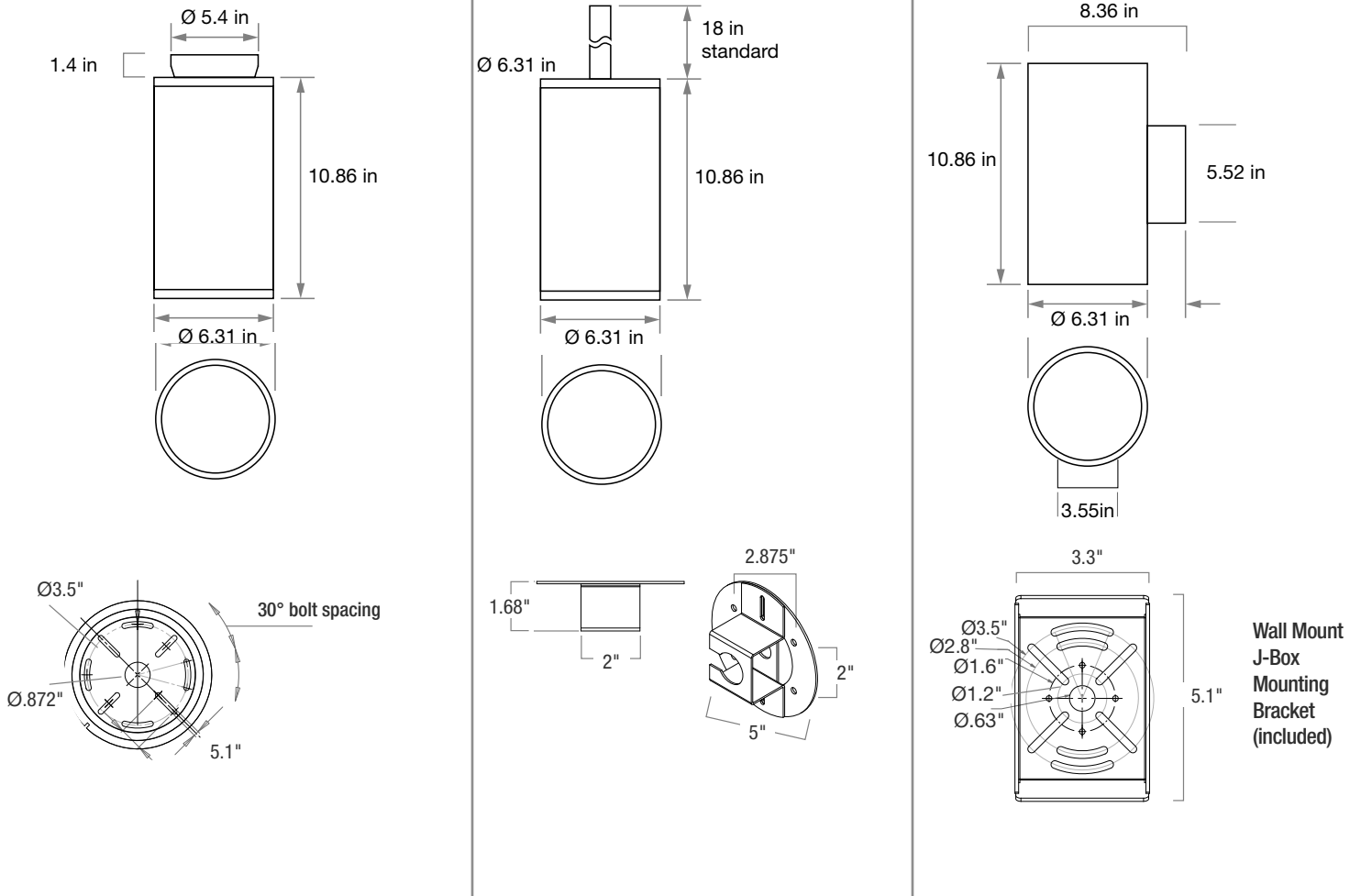

PHYSICAL

MOUNTING OPTIONS

CM - cord mount	5" W	SM - slope mount pendant	5" W
add to fixture height	.95" H	add to fixture height	.25" H

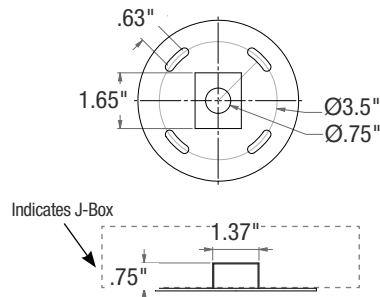
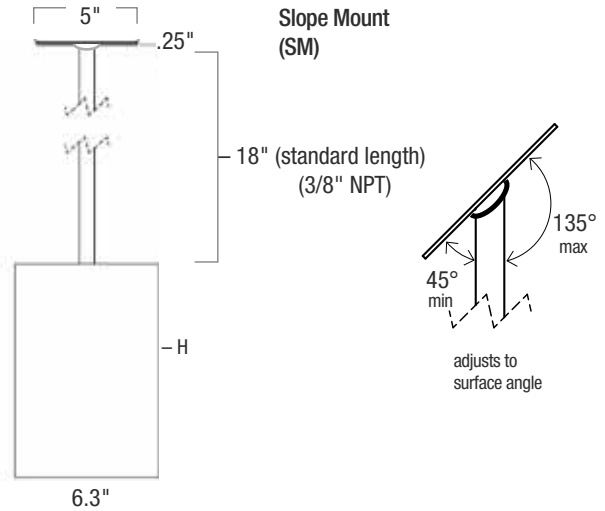
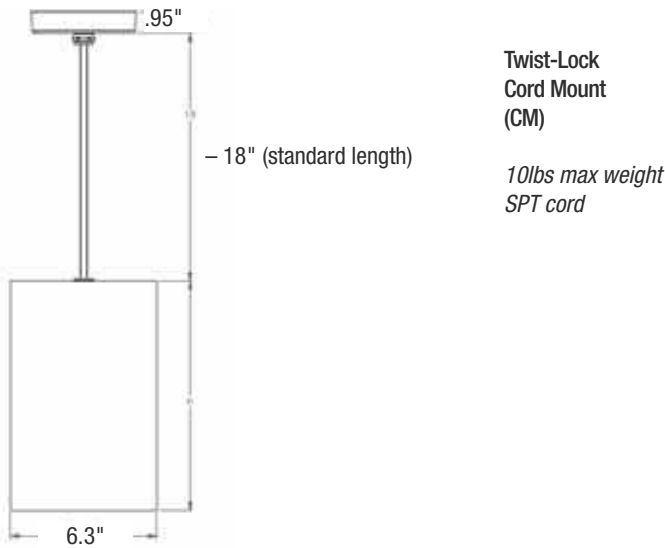

4.8"	outside diameter
3.5"	bolt diameter

Hang Straight Pendant
System J-Box Mounting
Bracket (2 part assembly
included)

CONSTRUCTION & FINISH

housing	no visible seams or fasteners, marine grade, corrosion resistant, solid aluminum extrusion, die-cast aluminum components
lens	IK05 impact compliant, clear anti-glare tempered glass
finish	7-stage UV stable polyester powder coat

SCALED DRAWINGS : FCC600

SURFACE MOUNT (SF)

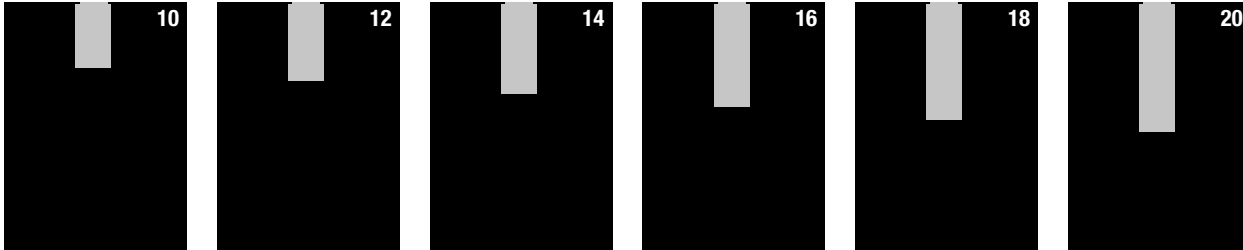

WALL MOUNT (WM)

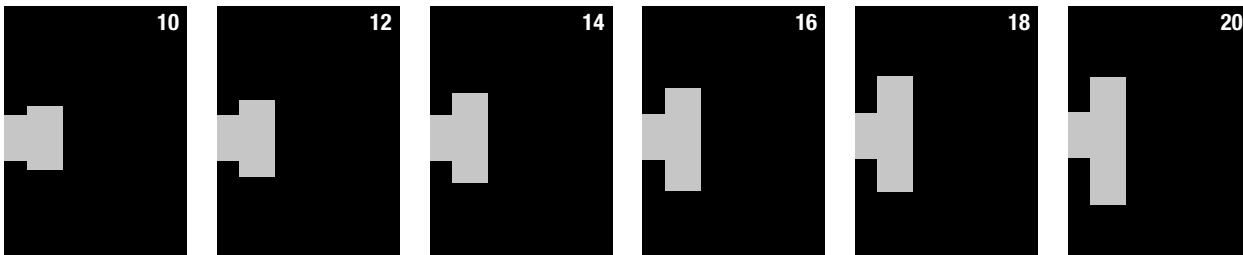

TWIST-LOCK PENDANT MOUNT (PD) - 18" Standard Pendant Length

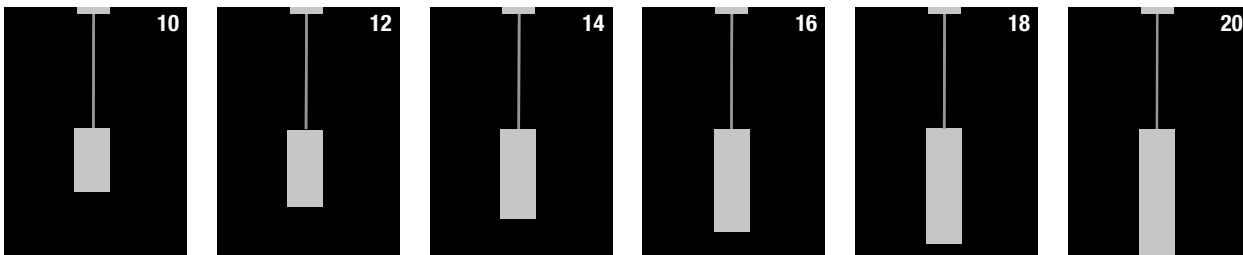

SCALED DRAWINGS : FCC600

SLOPE MOUNT (SM) - 18" Standard Pendant Length

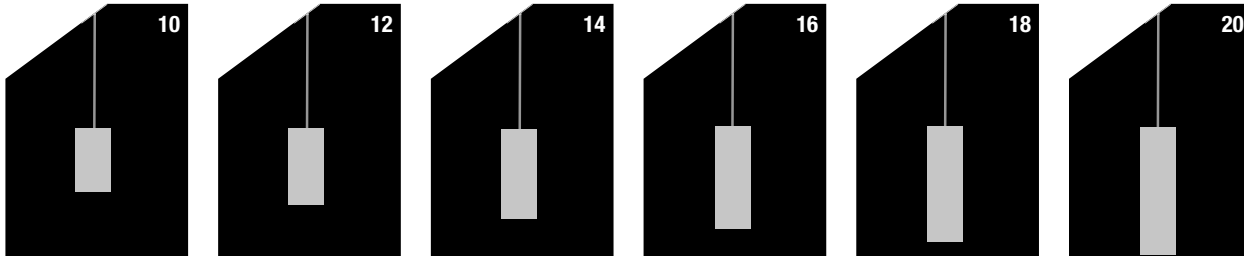

TWIST-LOCK CORD MOUNT (CM) - 18" Standard Cord Length

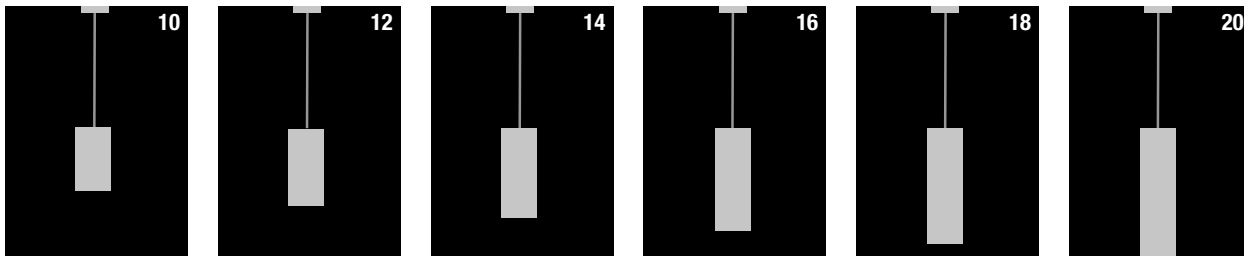

SPOT DISTRIBUTION

beam spread | 15°

MID SPOT DISTRIBUTION

25°

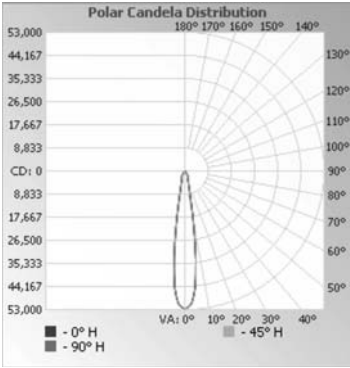

Center Beam fc	Beam
1.7ft	18,183 fc 0.5
3.3ft	4,826 fc 1.0
5.0ft	2,102 fc 1.5
6.7ft	1,171 fc 2.0
8.3ft	763 fc 2.4

Beam Angle: 16.6° / Field Angle: 31.1°

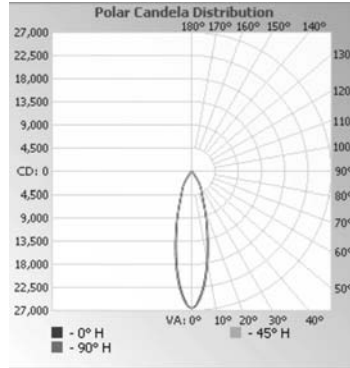

Center Beam fc	Beam Width
1.7ft	9,190 fc 0.8 ft
3.3ft	2,439 fc 1.5 ft
5.0ft	1,062 fc 2.3 ft
6.7ft	592 fc 3.1 ft
8.3ft	386 fc 3.9 ft
10.0ft	266 fc 4.7 ft

Beam Angle: 26.6° / Field Angle: 64.4°

FLOOD DISTRIBUTION

beam spread | 50°

WIDE FLOOD DISTRIBUTION

60°

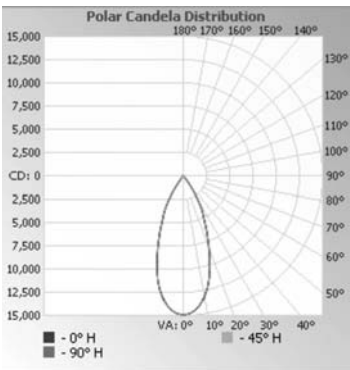

Center Beam fc	Beam Width
1.7ft	1,001 fc 1.8 ft
3.3ft	266 fc 3.5 ft
5.0ft	116 fc 5.3 ft
6.7ft	64.4 fc 7.1 ft
8.3ft	42.0 fc 8.8 ft
10.0ft	28.9 fc 10.6 ft

Beam Angle: 48.3° / Field Angle: 71.4°

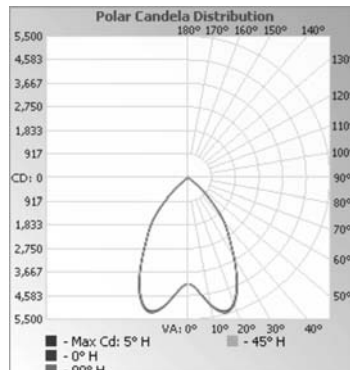

Center Beam fc	Beam Width
1.7ft	1,424 fc 2.4 ft
3.3ft	378 fc 4.7 ft
5.0ft	165 fc 7.1 ft
6.7ft	91.7 fc 9.5 ft
8.3ft	59.8 fc 11.7 ft
10.0ft	41.2 fc 14.1 ft

Beam Angle: 63.6° / Field Angle: 94.7°

REFER TO ADDITIONAL PHOTOMETRY AVAILABLE ON SOLIDSTATELUMINAIRE.COM

Photometry

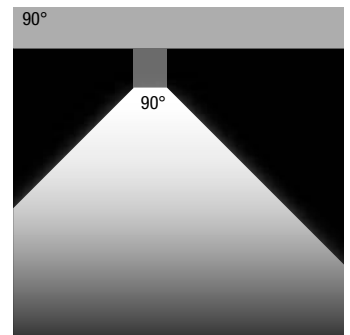
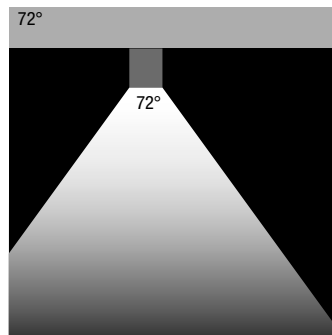
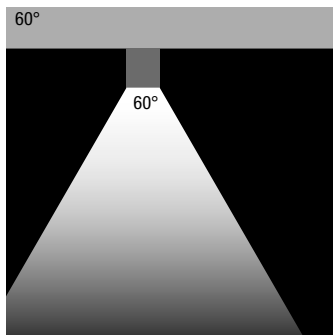
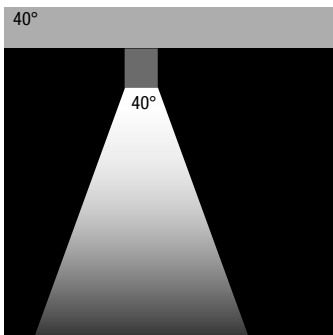
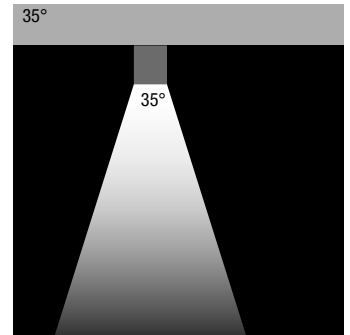
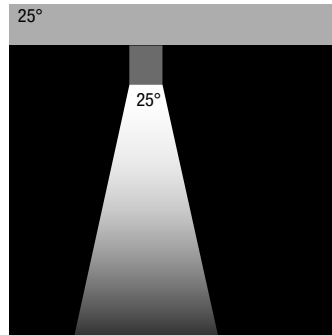
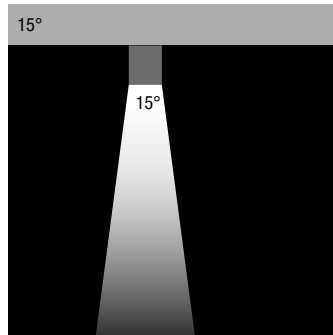
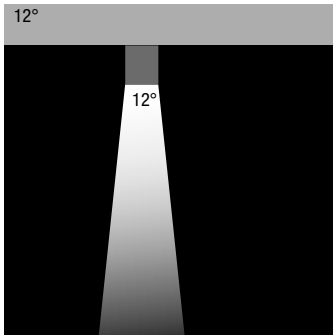

FCC600 Series

POWER SUPPLY

DRIVER OPTIONS

SSL Identifier	Driver	Dimming Protocol	Max Lumens for 10" and up Heights*	Max Lumens for 6" and 8" Heights*
STANDARD	SSL Standard	1%, 0-10V	6000	4500
TD	SSL Common	0.1%, 0-10V, Tuneable White, Dim-to-Warm	3000	3000
DL	SSL Common	0.1%, DALI	5000	4500
DMX	SSL Common	0.1%, DMX	5000	4500
ET	SSL Common	ELV or TRIAC, Dim to Off	4500	4500
L2	Lutron Hi-lume 1%	1%, Ecosystem/3-Wire	5500	4500
L5	Lutron Hi-lume Premier 0.1%	0.1%, Ecosystem, Soft-On, Fade-to-Black	2000	1500
E1	EldoLED SoloDrive	0-10V, Dim-to-Dark	6000	4500
E2	EldoLED SoloDrive	Dali, Dim-to-Dark	6000	4500
E3DW	EldoLED DualDrive	0-10V, Dim-to-Dark, Tuneable White, Dim-to-Warm	3000	3000
E3TW	EldoLED DualDrive	0-10V, Dim-to-Dark, Tuneable White, Dim-to-Warm	3000	3000
E4LDW	EldoLED DualDrive	Dali, Dim-to-Dark, Tuneable White, Dim-to-Warm	3000	3000
E4DLTW	EldoLED DualDrive	Dali, Dim-to-Dark, Tuneable White, Dim-to-Warm	3000	3000
E5	EldoLED EcoDrive	1%, 0-10V	5500	4500
E6	EldoLED EcoDrive	1%, Dali	5500	4500
E7	EldoLED PowerDrive	Dim-to-Off, DMX	6000	4500
P1	347V Option	10%, 0-10V	6000	4500

*Available in 500lm increments up to maximum stated

¹ For 93 CRI multiply by 0.86. For 97 CRI multiply by 0.75

EMR

EMR1	13.2" x 7.16" x 4.66" (Mounting Holes 10" x 5.8" Apart)	120V/277V	1500	15	1.5
EMR2	13.2" x 7.16" x 4.66" (Mounting Holes 10" x 5.8" Apart)	120V/277V	3000	30	1.5

Expanded Disclaimer: Due to continuous development and improvements, specifications are subject to change without notice. Solid State Lighting (SSL) is a registered trademark of Cree, Inc. All other trademarks are the property of their respective owners. Specifications are subject to change without notice. FCC is a registered trademark of the Federal Communications Commission. RoHS is a registered trademark of the European Union. FC is a registered trademark of the Federal Communications Commission. CE is a registered trademark of the European Union. 24 is a registered trademark of the European Union. All other trademarks are the property of their respective owners. © 2018 FC Lighting, Inc. All rights reserved. FC Lighting, Inc. is a US Commercial Lighting Manufacturer Since 1982.

DIMMER COMPATIBILITY

L1 (HI-LUME 1% SOFT-ON AND FADE-TO-BLACK)

Lutron EcoSystem Compatible Controls	Part Number		Drivers per Control			Measured Light Output Range
	120 V~	277 V~	EcoSystem Loops per Control	Drivers per EcoSystem Loop	Maximum Drivers per Control	
PowPak Dimming Modules	RMJ-ECO32-DV-B		1	32	32	100%-1%
	FCJ/FCJS-ECO ^{1,2}		1	3	3	100%-1%
Energi Savr Node	QSN-1ECO-S	N/A	1	64	64	100%-1%
	QSN-2ECO-S		2	64	128	
GRAFIK Eye QS / Homeworks QS control unit	QSGRJ-_E (wireless) QSGR-_E	N/A	1	64	64	100%-1%
Quantum Hub	QP2-_ _ 2C	N/A	2	64	128	100%-1%
	QP2-_ _ 4C		4	64	256	
	QP2-_ _ 6C		6	64	384	
	QP2-_ _ 8C		8	64	512	
Homeworks QS / myRoom Plus power module	LQSE-2ECO-D	N/A	2	64	128	100%-1%

¹ All devices connected to one FCJ/FCJS-ECO will be controlled together. Devices will dim to the same level as the result of a control command. For more detail on adjusting low-end light level refer to Application Note #555 at www.lutron.com.
² For the Line/Hot (L/H) terminal on the driver, it is preferred not to use the switched hot (red) wire from the control but rather the hot wire directly from the power source.

L2 AND L4 (HI-LUME 1% 3-WIRE)

Product	Part Number		Drivers per Control				Measured Light Output Range
	120 V~	277 V~	40 W Driver		50 W Driver		
			120 V~	277 V~	120 V~	277 V~	
3-wire Controls: Requires 3rd wire for control signal, see 3-wire diagram on previous page							
Nova Tr	NTF-10-	NTF-10-277-	1-41	1-44	1-31	1-36	100%-1%
	NTF-103P-	NTF-103P-277-	1-20	1-33	1-15	1-27	100%-1%
Nova	NF-10-	NF-10-277-	1-41	1-44	1-31	1-36	100%-1%
	NF-103P-	NF-103P-277-	1-20	1-33	1-15	1-27	100%-1%
Skylark	SF-10P-	SF-12P-277-	1-20	1-33	1-15	1-27	100%-1%
	SF-103P-	SF-12P-277-3	1-20	1-33	1-15	1-27	100%-1%
Diva	DVF-103P-	DVF-103P-277-	1-20	1-33	1-15	1-27	100%-1%
	DVSCF-103P-	DVSCF-103P-277-	1-20	1-33	1-15	1-27	100%-1%
Ariadni	AYF-103P-	AYF-103P-277-	1-20	1-44	1-15	1-27	100%-1%
Maestro	MAF-6AM-	MAF-6AM-277-	1-15	1-20	1-11	1-20	100%-1%
	MSCF-6AM-	MSCF-6AM-277-	1-15	1-20	1-11	1-20	100%-1%
Maestro Wireless	MRF2-F6AN-DV-		1-15	1-33	1-11	1-27	100%-1%
RadioRA 2	RRD-F6AN-DV-		1-15	1-33	1-11	1-27	100%-1%
HomeWorks QS	HQRD-F6AN-DV		1-15	1-33	1-11	1-27	100%-1%
Interfaces ¹	PHPM-3F-120	-	1-41	-	1-31	-	100%-1%
	PHPM-3F-DV		1-41	1-88	1-31	1-72	100%-1%
GP Dimming Panels	Various		1-41	1-88	1-31	1-72	100%-1%
EcoSystem Controls: See EcoSystem Controls wiring diagram on previous page							
PowPak dimming module with EcoSystem	RMJ-ECO32-DV-B		32 per EcoSystem link			100%-1%	
	FCJ-ECO, FCJS-ECO		3 per EcoSystem link ²			100%-1%	
Energi Savr Node with EcoSystem	QSN-1ECO-S, QSN-2ECO-S		64 per EcoSystem link			100%-1%	
GRAFIK Eye QS with EcoSystem	QSGRJ-_E, QSGR-_E	-	64 per EcoSystem link			100%-1%	
Quantum	Various		64 per EcoSystem link			100%-1%	

¹ For use with 3-wire controls or Commercial Systems, RadioRA 2 Systems or Home Systems applications.
² Up to 3 drivers controlled as a single zone (broadcast EcoSystem).



DIMMER COMPATIBILITY

L3 (HI-LUME 1% 2-WIRE NEUTRAL)

Product	Part Number	Low-End Setting/ Load-Type Setting ¹	Drivers per Control		
			A: Not Ganged	B: End of Gang	C: Middle of Gang
RadioRA 2 adaptive dimmer*	RRD-6NA-	Hi-lume 1% 2-Wire LTE LED ²	1–10, 400 W max	1–10, 400 W max	1–10, 400 W max
RA2 Select/RadioRA 2 600 W dimmer	RRD-6ND	Hi-lume 1% 2-Wire LTE LED ²	1–8, 350 W max	1–8, 350 W max	1–8, 350 W max
RadioRA 2 1000 W dimmer*	RRD-10ND-	Set Device type to *INC/MLV Neutral Dimmer*; Set High-End Trim to 99%; Set Low-End Trim to 35%	1–13	1–13	1–13
RadioRA 2 Architectural RF GRAFIK T phase selectable dimmer	RRT-G5NEW-	Trim low-end per APM App Note (Lutron P/N 048534)	1–10, 400 W max	1–10, 400 W max	1–10, 400 W max
RadioRA 2 Architectural RF GRAFIK T dimmer	RRT-G25LW-	Trim low-end per APM App Note (Lutron P/N 048534)	1–10, 400 W max	1–10, 400 W max	1–10, 400 W max
RadioRA 2 C•L hybrid seeTouch keypad	RRD-HN	Hi-lume 1% 2-Wire LTE LED	1–10, 200 W max	1–10, 200 W max	1–10, 200 W max
RadioRA 2 GRAFIK T C•L hybrid keypad	RRT-GH	Hi-lume 1% 2-Wire LTE LED	1–10, 400 W max	1–10, 400 W max	1–10, 400 W max
HomeWorks QS adaptive dimmer*	HQRD-6NA-	Hi-lume 1% 2-Wire LTE LED ²	1–10, 400 W max	1–10, 400 W max	1–10, 400 W max
HomeWorks QS 600 W dimmer*	HQRD-6ND-	Hi-lume 1% 2-Wire LTE LED ²	1–8, 350 W max	1–8, 350 W max	1–8, 350 W max
HomeWorks QS 1000 W dimmer*	HQRD-10ND-	Hi-lume 1% 2-Wire LTE LED ²	1–13	1–13	1–13
Maestro Wireless 600 W dimmer*	MRF2-6ND-120-	Trim low-end per APM App Note (Lutron P/N 048370)	1–8, 350 W max	1–8, 350 W max	1–8, 350 W max
Vive Maestro Wireless 600 W dimmer*	MRF2S-6ND-120-	Trim low-end per APM App Note (Lutron P/N 048370)	1–8, 350 W max	1–8, 350 W max	1–8, 350 W max
HomeWorks QS GRAFIK T hybrid keypad	HQRT-GH	Hi-lume 1% 2-Wire LTE LED	1–10, 400 W max	1–10, 400 W max	1–10, 400 W max
HomeWorks QS Architectural GRAFIK T dimmer	HQRT-G25LW-	Hi-lume 1% 2-Wire LTE LED	1–10, 400 W max	1–10, 400 W max	1–10, 400 W max
HomeWorks QS Architectural GRAFIK T phase selectable dimmer	HQRT-G5NEW-	Hi-lume 1% 2-Wire LTE LED	1–10, 400 W max	1–10, 400 W max	1–10, 400 W max
HomeWorks QS designer C•L hybrid seeTouch keypad	HQRD-HN	Hi-lume 1% 2-Wire LTE LED	1–10, 200 W max	1–10, 200 W max	1–10, 200 W max
GRAFIK T C•L 250 W dimmer*	GT-250M-, GTJ-250M-	Set low-end trim per dimmer installation instructions	1–10, 400 W max	1–10, 400 W max	1–10, 400 W max
Caséta Wireless Pro 1000 W dimmer*	PD-10NXD-	Trim low-end per instructions at www.casetawireless.com/lowend	1–13	1–13	1–13
Caséta Wireless phase selectable dimmer	PD-5NE-	Trim low-end per instructions at www.casetawireless.com/lowend	1–20, 400 W max	1–20, 400 W max	1–20, 400 W max

Note: All wattages are in terms of input wattage to the LED driver.

* See note on page 35 for control compatibility.

¹ Setting the low-end trim and load type is necessary to ensure optimal performance and 1% dimming capability.

Note: For information about Legacy Product use in existing control application, contact LEDs@lutron.com

² Also listed as *LED Lutron A-Series 2-Wire* or *Hi-lume A-Series LTE LED Driver 2-Wire* in previous software releases.



Specification Sheet



a US Commercial Lighting Manufacturer Since 1982

RP Rev. 11/19/2018

DIMMER COMPATIBILITY

L3 (HI-LUME 1% 2-WIRE NEUTRAL) - CONTINUED

Product	Part Number	Drivers per Control	Low-End Setting/Load-Type Setting ¹
myRoom DIN power module*	MQSE-4A1-D	1-6 (per output); 1 A maximum driver input current	Hi-lume 1% 2-Wire LTE LED ²
HomeWorks QS DIN power module*	LQSE-4A1-D	1-6 (per output); 1 A maximum driver input current	Hi-lume 1% 2-Wire LTE LED ²
HomeWorks QS Phase Adaptive DIN power module	LQSE-4A-120-D	1-6 (per output); 2 A maximum driver input current	Hi-lume 1% 2-Wire LTE LED ²
HomeWorks QS wallbox power module*	HQRJ-WPM-6D-120	2-10 (per output); 26 total per module	Hi-lume 1% 2-Wire LTE LED ²
HomeWorks wallbox power module*	HWI-WPM-6D-120	2-10 (per output); 26 total per module	Set load type to "GRX-FDBI" or "GRX-TVI"
GRAFIK Eye QS control unit*	QSGR-, QSGRJ-	2-10 (per output); 26 total per unit	Set load type to "Fluorescent Module"
GRAFIK Eye 3000 control unit*	GRX-3100-, GRX-3500-	2-10 (per output); 26 total per module	Set load type to "GRX-FDBI" or "GRX-TVI"
RPM-4U module (LCP, HomeWorks QS, GRAFIK Systems, Quantum)*	HW-RPM-4U-120, LP-RPM-4U-120	2-26 (per output); 26 total per module	Hi-lume 1% 2-Wire LTE LED ² Set load type to "2-1"
RPM-4A module (LCP, HomeWorks QS, GRAFIK Systems, Quantum)*	HW-RPM-4A-120, LP-RPM-4A-120	1-13 (per output); 26 total per module	Hi-lume 1% 2-Wire LTE LED ² Set load type to "2-1"
GP dimming panels*	Various	1-26	Set load type to "2-1"

* See note on page 35 for control compatibility.

¹ Setting the low-end trim and load type is necessary to ensure optimal performance and 1% dimming capability.

² Also listed as "LED Lutron A-Series 2-Wire" or "Hi-lume A-Series LTE LED Driver 2-Wire" in previous software releases.

Product	Part Number	Low-End Setting/Load-Type Setting ¹	Drivers per Control		
			A: Not Ganged	B: End of Gang	C: Middle of Gang
Ariadni C•L 250 W dimmer*	AYCL-253P-	Set low-end trim dial to 1 o'clock. Adjust slightly if needed. See dimmer installation instructions on how to adjust low-end trim.	1-8, 350 W max	1-8, 350 W max	1-8, 350 W max
Ariadni C•L 150 W dimmer	TGCL-153P, AYCL-153P-	Set low-end trim dial to 1 o'clock. Adjust slightly if needed. See dimmer installation instructions on how to adjust low-end trim.	1-6, 250 W max	1-6, 250 W max	1-6, 250 W max
Diva C•L 250 W dimmer*	DVCL-253P-, DVSCCL-253P-	Set low-end trim dial to 10 o'clock. Adjust slightly if needed. See dimmer installation instructions on how to adjust low-end trim.	1-8, 350 W max	1-8, 350 W max	1-8, 350 W max
Diva C•L 150 W dimmer	DVCL-153P-, DVSCCL-153P-	Set low-end trim dial to 10 o'clock. Adjust slightly if needed. See dimmer installation instructions on how to adjust low-end trim.	1-6, 250 W max	1-6, 250 W max	1-6, 250 W max
Nova Tr C•L 250 W dimmer*	NTCL-250-	Set low-end trim dial to 10 o'clock. Adjust slightly if needed. See dimmer installation instructions on how to adjust low-end trim.	1-10, 400 W max	1-10, 400 W max	1-10, 400 W max
Lumea C•L 150 W dimmer	LECL-153P-	Set low-end trim dial to 10 o'clock. Adjust slightly if needed. See dimmer installation instructions on how to adjust low-end trim.	1-6, 250 W max	1-6, 250 W max	1-6, 250 W max
Skylark C•L 150 W dimmer	SCL-153P-	Set low-end trim dial to 10 o'clock. Adjust slightly if needed. See dimmer installation instructions on how to adjust low-end trim.	1-6, 250 W max	1-6, 250 W max	1-6, 250 W max
Contour C•L 150 W dimmer	CTCL-153P-	Set low-end trim dial to 10 o'clock. Adjust slightly if needed. See dimmer installation instructions on how to adjust low-end trim.	1-6, 250 W max	1-6, 250 W max	1-6, 250 W max

Note: All wattages are in terms of input wattage to the LED driver.

* See note on page 35 for control compatibility.

¹ Setting the low-end trim and load type is necessary to ensure optimal performance and 1% dimming capability.

Note: For information about Legacy Product use in existing control application, contact LEDs@lutron.com

Expanded Disclaimer: Due to continuous development and improvements, specifications are subject to change without notice. FC Lighting and Solid State Luminaires reserves the right to change lab test details or specifications without notice. Product use certifies agreement to FC Lighting terms and conditions. FCC Series Cylinder Lights are engineered and produced in our Illinois manufacturing facility.



Specification Sheet



a US Commercial Lighting Manufacturer Since 1982

RP Rev. 11/19/2018

DIMMER COMPATIBILITY

L3 (HI-LUME 1% 2-WIRE NEUTRAL) - CONTINUED

Product	Part Number	Low-End Setting/Load-Type Setting ¹	Drivers per Control		
			A: Not Ganged	B: End of Gang	C: Middle of Gang
Maestro C•L 150 W dimmer	MACL-153M-	Trim low-end per APM App Note (Lutron P/N 048370)	1-6, 250 W max	1-6, 250 W max	1-6, 250 W max
Maestro C•L 150 W sensor	MSCL-OP153M-, MSCL-VP153M-	Trim low-end per APM App Note (Lutron P/N 048370)	1-6, 250 W max	1-6, 250 W max	1-6, 250 W max
Vive Maestro C•L 150 W dimmer	MRF2S-6CL-	Trim low-end per APM App Note (Lutron P/N 048370)	1-6, 250 W max	1-6, 250 W max	1-6, 250 W max
GRAFIK T C•L 150 W dimmer	GTJ-150-	Set low-end trim per dimmer installation instructions	1-6, 250 W max	1-6, 250 W max	1-6, 250 W max
Maestro Wireless C•L 150 W dimmer	MRF2-6CL-	Trim low-end per APM App Note (Lutron P/N 048370)	1-6, 250 W max	1-6, 250 W max	1-6, 250 W max
RadioRA 2 C•L 150 W dimmer	RRD-6CL-	Set low-end trim per dimmer installation instructions	1-6, 250 W max	1-6, 250 W max	1-6, 250 W max
HomeWorks QS Designer C•L 150 W dimmer	HQRD-6CL-	Hi-lume 1% 2-Wire LTE LED	1-6, 250 W max	1-6, 250 W max	1-6, 250 W max
Caséta Wireless C•L Dimmer	PD-6WCL-	Trim low-end per instructions at www.casetawireless.com/lowend	1-6, 250 W max	1-6, 250 W max	1-6, 250 W max
RadioRA 2 Architectural RF GRAFIK T dimmer ²	RRT-G25LW-	Trim low-end per APM App Note (Lutron P/N 048534)	1-10, 400 W max	1-10, 400 W max	1-10, 400 W max
HomeWorks QS Architectural GRAFIK T dimmer ²	HQRT-G25LW-	Hi-lume 1% 2-Wire LTE LED	1-10, 400 W max	1-10, 400 W max	1-10, 400 W max
GRAFIK T C•L 250 W dimmer ^{*,2}	GT-250M-, GTJ-250M-	Set low-end trim per dimmer installation instructions	1-10, 400 W max	1-10, 400 W max	1-10, 400 W max

Note: All wattages are in terms of input wattage to the LED driver.

* See note on page 35 for control compatibility.

¹ Setting the low-end trim and load type is necessary to ensure optimal performance and 1% dimming capability.

Note: For information about Legacy Product use in existing control application, contact LEDs@lutron.com

² Minimum number of drivers for GRAFIK T will vary based on the number of companion dimmers (model number GT-AD) connected. Refer to the GRAFIK T Spec Submittal, Lutron P/N 369826, at www.lutron.com This only applies when neutral is not connected.

Expanded Disclaimer: Due to continuous development and improvements, specifications are subject to change without notice. FC Lighting and Solid State Luminaires reserves the right to change lab test details or specifications without notice. Product use certifies agreement to FC Lighting terms and conditions. FCC Series Cylinder Lights are engineered and produced in our Illinois manufacturing facility.



DIMMER COMPATIBILITY

L5 (LUTRON 5-SERIES ECOSYSTEM)

Lutron EcoSystem Compatible Controls	Part Number		Drivers per Control			Measured Light Output Range
	120 V~	277 V~	EcoSystem Loops per Control	Drivers per EcoSystem Loop	Maximum Drivers per Control	
PowPak Dimming Modules	RMJ-ECO32-DV-B		1	32	32	100%-5%
	FCJ/FCJS-ECO ^{1,2}		1	3	3	100%-5%
Energi Savr Node	QSN-1ECO-S	N/A	1	64	64	100%-5%
	QSN-2ECO-S		2	64	128	
GRAFIK Eye QS / Homeworks QS control unit	QSGRJ-_E (wireless) QSGR-_E	N/A	1	64	64	100%-5%
Quantum Hub	QP2-__2C	N/A	2	64	128	100%-5%
	QP2-__4C		4	64	256	
	QP2-__6C		6	64	384	
	QP2-__8C		8	64	512	
Homeworks QS / myRoom Plus power module	LQSE-2ECO-D	N/A	2	64	128	100%-5%

¹ All devices connected to one FCJ/FCJS-ECO will be controlled together. Devices will dim to the same level as the result of a control command. For more detail on adjusting low-end light level refer to Application Note #556 at www.lutron.com.

² For the Line/Hot (L/H) terminal on the driver, it is preferred not to use the switched hot (red) wire from the control but rather the hot wire directly from the power source.

L6 (HI-LUME PREMIER 0.1%)

Lutron EcoSystem Compatible Controls	Part Number		Drivers per Control		
	120 V~	277 V~	EcoSystem Loops per Control	Drivers per EcoSystem Loop	Maximum Drivers per Control
PowPak Dimming Modules	RMJ-ECO32-DV-B		1	32	32
	FCJ/FCJS-ECO ¹		1	3	3
Energi Savr Node	QSN-1ECO-S	N/A	1	64	64
	QSN-2ECO-S		2	64	128
GRAFIK Eye QS / HomeWorks QS control unit	QSGRJ-_E (wireless) QSGR-_E	N/A	1	64	64
Quantum Hub	QP2-__2C	N/A	2	64	128
	QP2-__4C		4	64	256
	QP2-__6C		6	64	384
	QP2-__8C		8	64	512
HomeWorks QS / myRoom Plus power module	LQSE-2ECO-D	N/A	2	64	128

¹ All devices connected to one FCJ/FCJS-ECO will be controlled together. Devices will dim to the same level as the result of a control command. For more detail on adjusting low-end light level refer to Application Note #556 at www.lutron.com.



DIMMER COMPATIBILITY

ELDOLED DALI DIMMING MODELS (E2, E4, E6(1%), E8)

Manufacturer	Dimmer	Manufacturer Part Number	E2, E4, E8 Dim Range	E6 Dim Range	Qty Fixtures Per Dimmer
Lutron	Interfaces	GRX-TVI w/ GRX3503	Dim to off	100% - 1%	Reference Dimmer's Manufacturer Specification Sheet
Lutron	Energi Savr Node	QSN-4T16-S	Dim to off	100% - 1%	
Lutron	Nova T	NTFTV with PP-20	Dim to off	100% - 1%	
Lutron	Divva	DVTV/NFTV with PP-20	Dim to off	100% - 1%	
Lutron	GP Dimming Panels	TVM2 Module	Dim to off	100% - 1%	
enlighted	Control Unit	CU-3E-1R	Dim to off	100% - 1%	
Sensor Switch	nIO	nIO EZ	Dim to off	100% - 1%	

ELDOLED 0-10V DIMMING MODELS (E1, E3, E5 (1%), E7)

Manufacturer	Dimmer	Manufacturer Part Number	E1, E3, E7 Dim Range	E5 Dim. Range	Qty Fixtures Per Dimmer
ABB	i-bus	SD/S 2.16.1	Dim to off	100% - 1%	Reference Dimmer's Manufacturer Specification Sheet
Bush-Jaeger	Electronic Potentiometer	Z112U-101	Dim to off	100% - 1%	
Crestron	DIN Rail Analog Output Module	DIN-A08	Dim to off	100% - 1%	
Crestron	DIN Rail 0-10V Fluorescent Dimmer	DIN-4DIMFLV4	Dim to off	100% - 1%	
Crestron	Green Light	GLPAC-DIMFLV4-, GLPAC-DIMFLV8	Dim to off	100% - 1%	
Crestron	Green Light Power Pack	GLPP-DIMFLVEX-PM, GLPP-1DIMFLV2EX-PM, GLPP-1DIMFLV3EX-PM	Dim to off	100% - 1%	
Crestron	iLux 0-10V Dimmer Expansion Module	CLS-EXP-DIMFLV	Dim to off	100% - 1%	
Crestron	Modules	GLX-DIMFLV8, GLXP-DIMFLV8	Dim to off	100% - 1%	
enlighted	Control Unit	CU-3E-1R	Dim to off	100% - 1%	
Jung	Electronic Potentiometer	Z40-10	Dim to off	100% - 1%	
Leviton	Iluma Tech dimmer	IP710-DLX	Dim to off	100% - 1%	
Lightolier (Philips)	Momentum (120V Only)	ZP600FAM120	Dim to off	100% - 1%	
Merten	Electronic Potentiometer	5729	Dim to off	100% - 1%	
Pass % Seymour	Titan	CD4FB-W	Dim to off	100% - 1%	
Synergy	Wallbox Dimmers	ISD BC	Dim to off	100% - 1%	
Watt Stopper	Miro	DCLV1	Dim to off	100% - 1%	

ELV TYPE DIMMING DRIVER OPTION (ELV)

Manufacturer	Dimmer	Qty Fixtures Per Dimmer
Leviton	IPL06-10Z	Reference Dimmer's Manufacturer Specification Sheet
Leviton	6613-xxx	
Lutron	S-600P	
Lutron	S-603P	
Lutron	DV-600P	
Lutron	DV-603P	
Lutron	DVSC-603P	
Lutron	CT-600P	
Lutron	CT-603P	

ET Drive Option Dimmer Compatibility: ELV (Reverse Phase Dimming, 120V only)

Manufacturer	Dimmer	Qty Fixtures Per Dimmer
Leviton	IPE04-xxx	Reference Dimmer's Manufacturer Specification Sheet
Leviton	6615	
Lutron	NTELV-300	
Lutron	NTELV-600	
Lutron	SELV-300P	
Lutron	SELV-303P	
Lutron	DVELV-300P	
Lutron	DVELV-303P	



Railroad

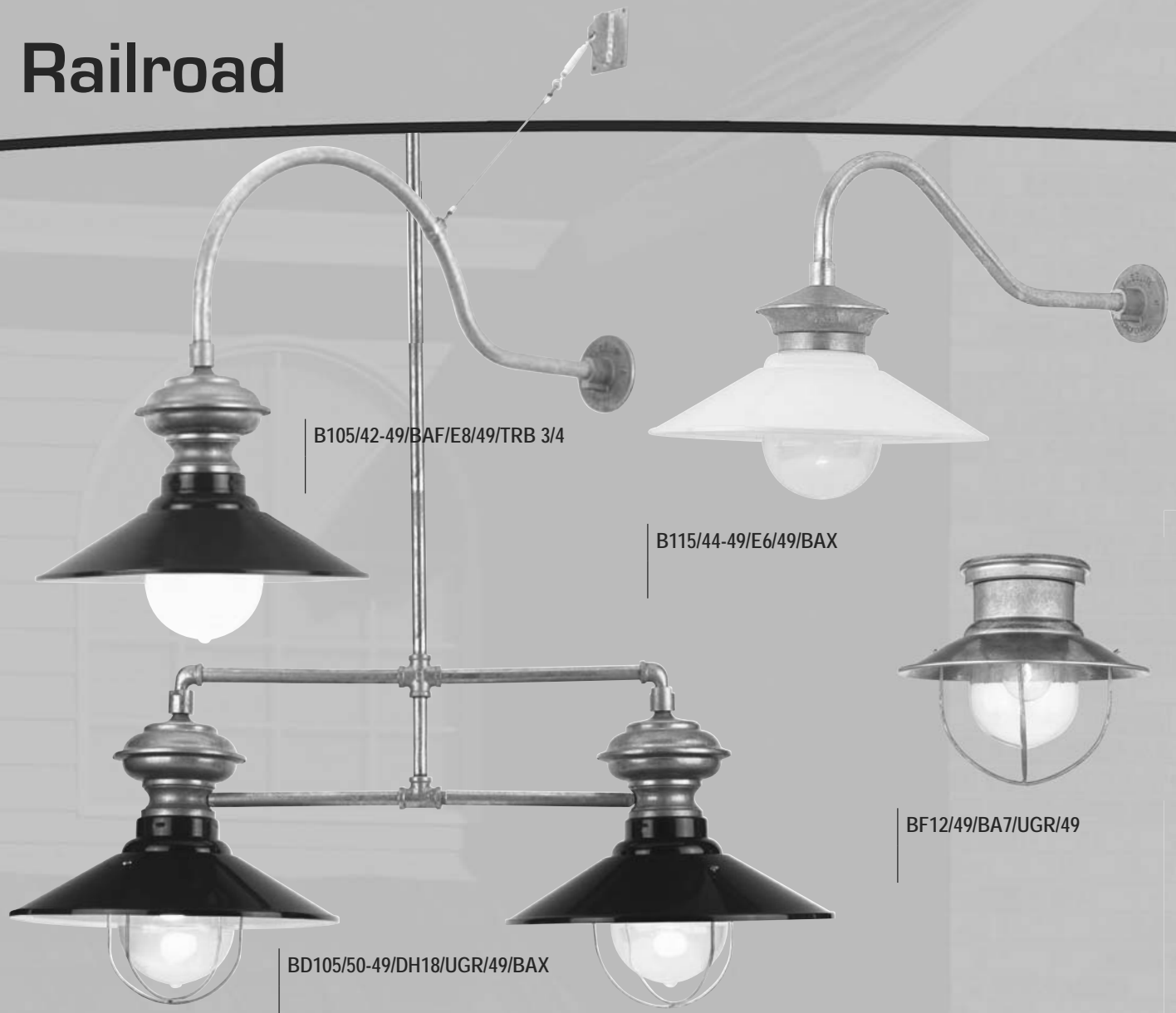

B104

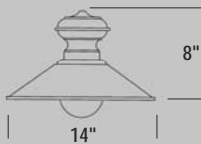

B105

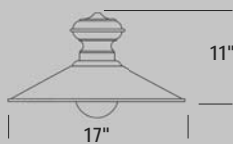

B114

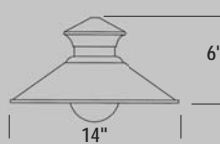

B115

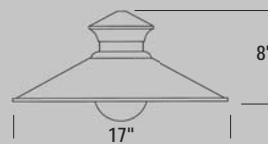

BF12

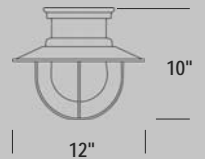

MODEL	COLOR	MOUNTING SOURCE	LIGHT SOURCE				NOTES
			Inc	CF	HID (MH & HPS)	LED	
B104	40, 41, 42, 43, 44,	Page 55-58 for arm extension	100W	26, 32, or 42W*	35, 50 or 70W **	21W	<i>See page 67 for ACCESSORIES</i> <i>See page 68 for GLASS OPTIONS</i>
B105	45, 46, 48, 49, 50,	Page 59-63 for post mts. & poles	200W	26, 32, or 42W*	35, 50, 70 or 100W **	21W	
BD105	51, 52, 53, 54, 55,	Page 66 for stems, cords & canopies	200W	26, 32, or 42W*	N/A	42W	
B114	57, 58, 59, 60, 61,	Page 66 for cable & chain	100W	26, 32, or 42W*	35, 50 or 70W **	21W	
B115	62, 63	Page 66 for mounting hubs	200W	26, 32, or 42W*	35, 50, 70 or 100W **	21W	
BF12			100W	26, 32, or 42W*	35, 50, 70 or 100W **	21W	
			<i>*See page 65 for REMOTE BALLASTS **See page 64 for REMOTE BALLASTS</i>				

Wall Mounts

B10

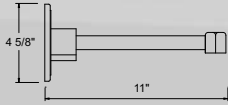

B11

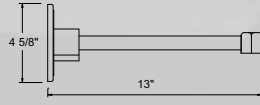

B101

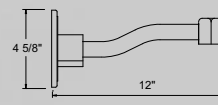

B12

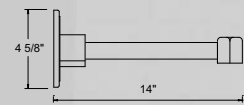

B13

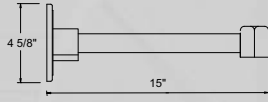

WM10

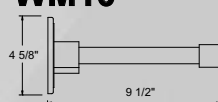

WM11

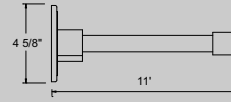

WM12

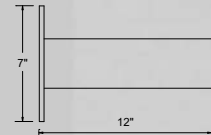

WM13

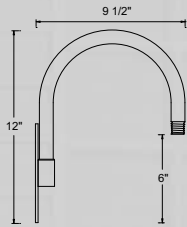

WM13R

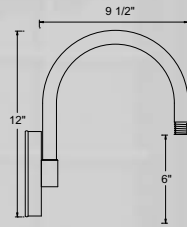

WM13X

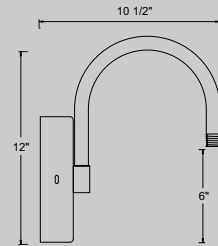

WM24

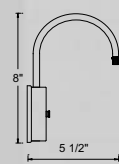

WM14

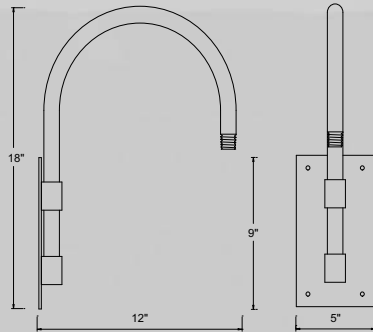

WM14X

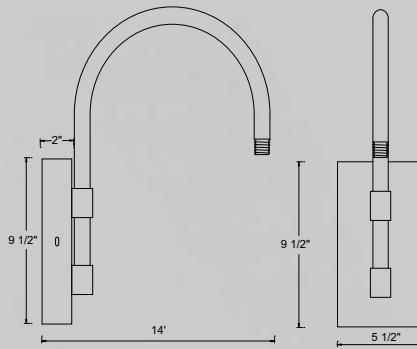

WM25

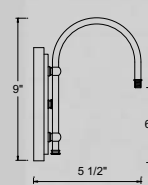

WM15

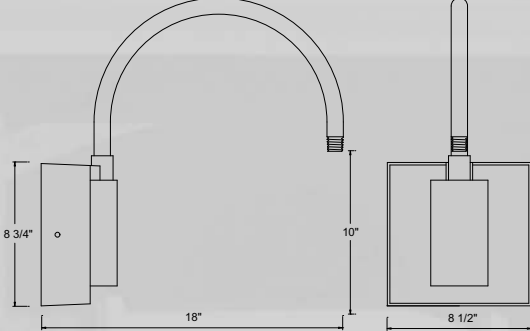

WM28

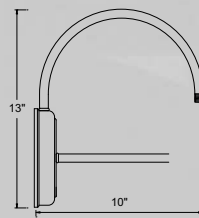

WM27

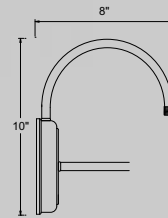

WM26

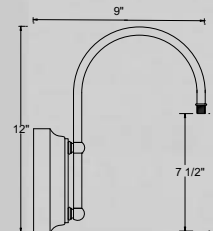

ER7108

Specification Sheet

Exterior Recessed



ER7108-BK

Other Finishes:



GY - GREY



BK - BLACK

PROJECT					
DATE				TYPE	
Voltage	Watt	LED Lumens	Delivered Lumens	Finish(es)	
120V	8W	600lm	235lm	BK - Black	Color Temp 3000K
120V	8W	600lm	303lm	GY - Grey	CRI (Ra) >90
					Dimming 100% - 10%
					Rated Life 50,000 hours

*Preliminary figures

DRY LOCATION - box sold separately



INTERIOR WIRING
GALVANIZED BACK-BOX
ER7108-BOX

WET LOCATION - box sold separately



DIE-CAST WET LOCATION BOX
ER7108-CBOX

Product Descriptions

This exterior recessed light is a classic, rectangle-shaped, 7-1/5 inch tall die-cast aluminum recessed light and utilizes LED light sources. The housing is designed to light an exterior or interior staircase or any other area that calls for a lighting from a concealed aperture. Choose from black or grey powder coat. Newport is dimmable. Requires either back-box with fixture ER7108-MBOX (Dry Location) or ER7108-CBOX (Wet Location).

Product Details

- High system efficacy
- Low total life cycle cost
- No visible flicker AC operation
- ETL listed
- 5-year LED and fixture warranty.
- Complete warranty terms located at: www.kuzcolighting.com/warranty
- Utilizes our patented Driverless LED Light Engine technology - connects directly to AC, no external driver needed.
- Die-cast aluminum with powder coat finish and polymeric lens
- Dimmable with ELV dimmer (not included)
- Custom options available
- High system efficacy
- Low total life cycle cost
- No visible flicker AC operation

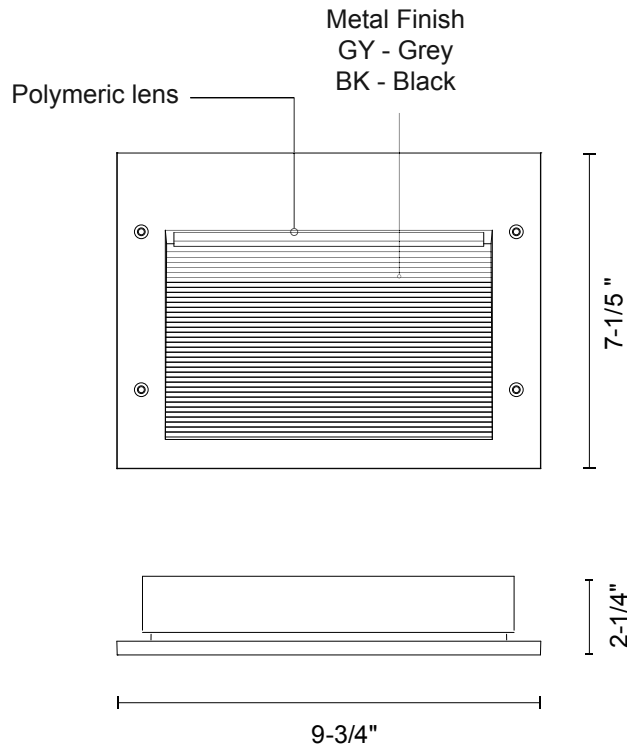

Comments:

E110 Series

Architectural LED Trapezoid Wallpack



DESCRIPTION

The E110 Series is a traditional full cutoff geometric sconce designed for optimal light control and distribution. Its die-cast aluminum construction provides ideal thermal management. Lumen packages from 3360 to 9800 are available in 4000K and 5000K CCT and a Type III distribution. This product offers project flexibility with photocontrol, integral motion sensor and battery backup options. The E110 is DLC Qualified for maximum energy savings and utility rebates. This family of product is offered in two housing sizes to complement new construction or retrofit applications, accommodating mounting heights up to 30'.

SPECIFICATIONS

Construction:

- Die-cast aluminum housing with stainless steel hardware and powder coated bronze finish
- UV-stabilized polycarbonate lens
- Integral heat sink maximizes heat dissipation for longer LED life
- Hinged back box isolates drivers from LEDs and offers easy access to drivers
- Back box includes three conduit entry points (one on top and two on the sides) as well as a knockout on the bottom for optional sensor

Optics/LEDs:

- No uplight design to minimize light pollution
- 30W to 90W LED models replace 100W to as high as 400W HID for up to 70% energy savings
- Efficacies up to 113 LPW maximize utility rebates
- Type III distribution
- Available in 4000K and 5000K CCT
- CRI ≥80
- 70,000 hrs L70

Electrical:

- 120-277VAC, 50/60Hz
- 0-10V Dimming driver

Testing & Compliance:

- cULus Listed for Wet Locations
- DesignLights Consortium® (DLC) Qualified (consult QPL for specific models)
- Operating temperatures: -40°C to 50°C (-40°F to 122°F)

Installation:

- Housing hinges to back box for easy installation
- Back box accommodates conduit entry as well as optional sensor
- Mounts to a standard 3-1/2" or 4" square electrical J-box

Options:

- Integral Battery Backup (BB) operates for 90 minutes, providing over 800 lumens for path of egress. Rated for ambient temperatures of 0°C to 25°C (32°F to 77°F)
- Factory installed 120/277VAC button type photocontrol (PC)
- Factory installed integral dimming occupancy sensor (SC)

Accessories:

- Dimming sensor for field installation (TL-MSSW)
- Remote control for TL-MSSW sensor (TL-MSSW-REMOTE)
- Button type universal photocontrol sensor 120/277VAC (PCU)

Warranty:

- Five Year Warranty (Terms and Conditions Apply)



Specs at a Glance			
Model	E110-30	E110-45	E110-90
Wattage (W)*	30W	45W	90W
Lumens (lm)	3360	4900	9800
Efficacy (LPW)	113	108	109
Equivalency (HID)	100-150 Watt	175-250 Watt	250-400 Watt
Distribution	Type III		
CCT (K)	4000K, 5000K		
CRI	≥80		
Input Voltage	120-277VAC, 50/60Hz		
Operating Temp	-40°C to 50°C (-40°F to 122°F)		
Certifications	cULus Listed for Wet Locations, DLC		
Warranty	5 Years		
Weight	9.8 lbs	9.8 lbs	15.0 lbs

*Nominal Wattage. Tested at 5000K CCT. See performance table for more detailed lumen information.

Note: Environment and application will affect actual performance. Typical values and 25°C used for testing.

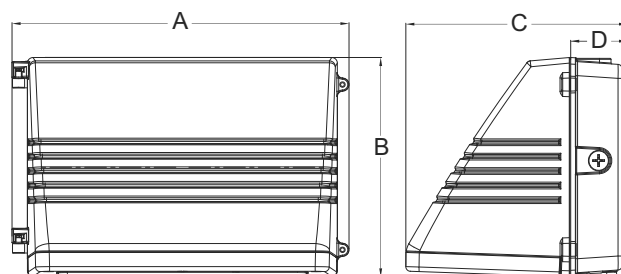

Model	A	B	C	D
E110-30	14.2"	9.8"	8.8"	2.5"
E110-45	14.2"	9.8"	8.8"	2.5"
E110-90	18.1"	9.8"	11.2"	2.5"

Model: _____ Date: _____
 Accessories: _____
 Job Name: _____ Type: _____

Ordering Information (Example: E110-45-VS-4K-BR-BB)

Series	Wattage	Input Voltage	CCT	Finish	Options	Accessories ¹ (Field Installed)
E110	30 = 30W	VS = 120-277VAC	4K = 4000K	BR = Bronze	BB = Battery Backup	PCU = 120-277VAC Button Photocontrol
	45 = 45W		5K = 5000K		SC = Dimming Sensor	TL-MSSW = Dimming Sensor
	90 = 90W				PC = Button Photocontrol 120/277VAC	TL-MSSW-REMOTE = Remote for Sensor

Notes

¹ Order as a separate line item. Shipped in a separate box for final installation in the field

Performance Data

Model	Wattage	CCT	Distribution	Lumen Output (lumens)	Efficacy
E110-30-VS-4K-XX	30	4000K	Type III	3360	112
E110-30-VS-5K-XX	30	5000K	Type III	3390	113
E110-45-VS-4K-XX	45	4000K	Type III	4800	107
E110-45-VS-5K-XX	45	5000K	Type III	4900	108
E110-90-VS-4K-XX	90	4000K	Type III	9700	108
E110-90-VS-5K-XX	90	5000K	Type III	9800	109

Sample Photometry

E110-30-VS-4K
 IES: TYPE III Very Short
 MOUNTING HEIGHT: 10'
 TILT: ZERO
 HORIZONTAL SPACING CRITERIA: 1.44

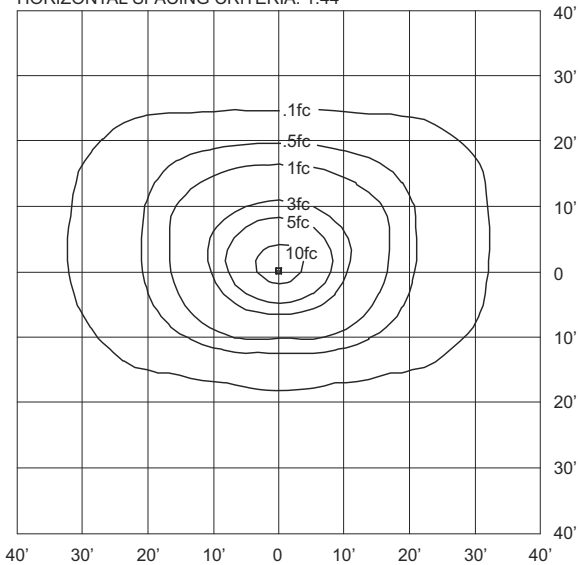

Motion Sensor Details - Option (SC) and Accessories (TL-MSSW and TL-MSSW-REMOTE)



SC Option (Factory Installed)
 TL-MSSW Accessory (Sold Separately)



Sensor Dip Switch Settings
 (Dip Switches on Sensor)



TL-MSSW-REMOTE
 Accessory
 (Sold Separately)

Sensor Settings (Remote)

DETECTION RADIUS/ANGLE	MAX 60°/360°
MOUNTING HEIGHT	MAX 40'
REMOTE RANGE	MAX 33'
FREQUENCY	5.8 GHz
HIGH MODE	70%, 80%, 90%, 100% (DEFAULT 100%)
SENSITIVITY	20%, 50%, 75%, 100% (DEFAULT 100%)
HOLD TIME	10sec, 1min, 5min, 10min, 15min, 20min, 30min, 60min (DEFAULT 5min)
DAYLIGHT HARVESTING	☀️, (disabled), 10Lux, 30Lux, 50Lux (DEFAULT disabled)
STANDBY DIM SETTING	0, 10%, 20%, 30%, OFF (∞) (DEFAULT 30%)
STANDBY TIME SETTING (TO OFF)	ON (disabled), 1min, 30min, 60min (DEFAULT 60min)

FCSL1000 Series

Direct AC Wired Die-Cast Step Light for installation in standard, single-gang j-box for interior or exterior applications

ADA



ORDERING

This product has Quick Ship options available. Click to view the FC|SSL Quick Ship catalog.

SERIES	VOLTAGE	SOURCE/TEMPERATURE/LAMP	FINISH	OPTIONS
FCSL1011	120V	LED 27K (3.5W)	WH White	CL Clear Lens
FCSL1012		3K * See Lumen Chart on pg. 2	BK Black	BL Blue Lens
FCSL1013		35K	BZ Bronze	AL Amber Lens
FCSL1014		4K	SL Silver	AM Anti-Microbial Paint
FCSL1015			CC Custom Color	HP Horizontal Position

SPECIFICATION

MOUNTING

- Mounts directly to single-gang J-Box. Use minimum inside dimension, 4"H X 2"W X 1.75"D
- To use horizontal mounting option, configuration must be stated at time of order. Must be configured in factory. Horizontal configuration by unauthorized individuals will void the warranty.

CONSTRUCTION

- Marine grade, corrosion resistant, heavy walled, high pressure die-cast aluminum.
- Neoprene gasket provides seal to J-Box
- Frosted glass lens is standard. Clear glass lens (**CL**) or available static colors optional.

LED

- Lumens stated are minimum delivered out of the luminaire. LED lifetime is greater than or equal to 70,000 hours with lumen depreciation less than L70. All of our luminaire tested to LM 80 with a minimum CRI of 80 and color consistency of 4-step MacAdam Ellipse. Integral power supply standard. Consult factory for dimming and any single color options. Input voltage 120V.
- Works with standard ELV Dimming Module. Dims to 10%.

FINISH

- Six stage chemical pre-treatment process that includes iron phosphate, to prepare the substrate for a UV stable, super durable standard polyester powder coat.
- Anti-microbial paint available as option.

LISTING

- cETLus and CA listed for interior and exterior wet locations. IP65 Rating.

PHOTOMETRY

FCSL1015 120V LED 4000K 76 Lumens

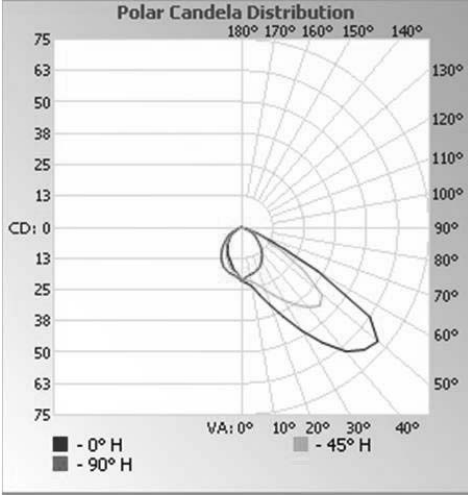

	Illuminance at a Distance	
	Center Beam fc	Beam Width
1.7ft	7.44 fc	1.2 ft 1.8 ft
3.3ft	1.97 fc	2.3 ft 3.6 ft
5.0ft	0.86 fc	3.4 ft 5.4 ft
6.7ft	0.48 fc	4.6 ft 7.3 ft
8.3ft	0.31 fc	5.7 ft 9.0 ft
10.0ft	0.22 fc	6.9 ft 10.8 ft

■ Vert. Spread: 38.0°
 ■ Horiz. Spread: 56.9°

FIXTURE	LUMENS
FCSL1011	35
FCSL1012	10
FCSL1013	15
FCSL1014	50
FCSL1015	76

DIMENSIONS

FCSL1011

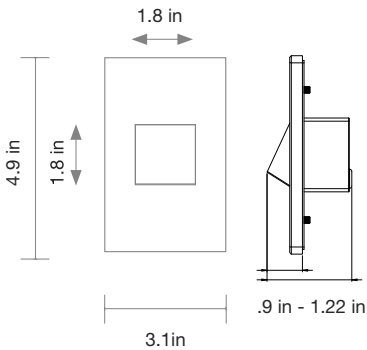

hood

FCSL1012

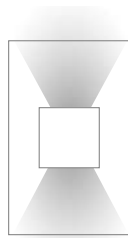

2 window indirect / 4 window indirect

FCSL1013

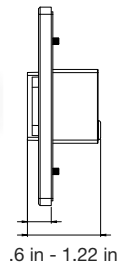
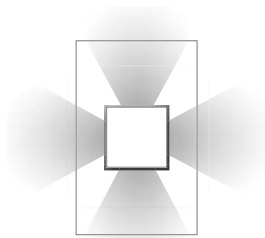

FCSL1014



louvered

FCSL1015

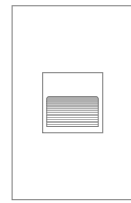

recessed cut-off

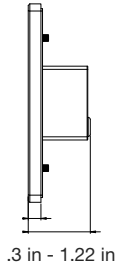

.3 in - 1.22 in