

PLAN AND PROFILE

RAYOVAC DR. CITY OF MADISON

**REV. 2018 08-17 JPS
ADDED BUS PADS, SIDEWALK
RAMPS, AND ISLAND.
ADJUSTED EX. AND PR.
SIDEWALK TO KEEP BUS PADS
UNDER 2%. SHIFTED ELM
TREE TO BE AWAY FROM
SIDEWALK RAMP.**

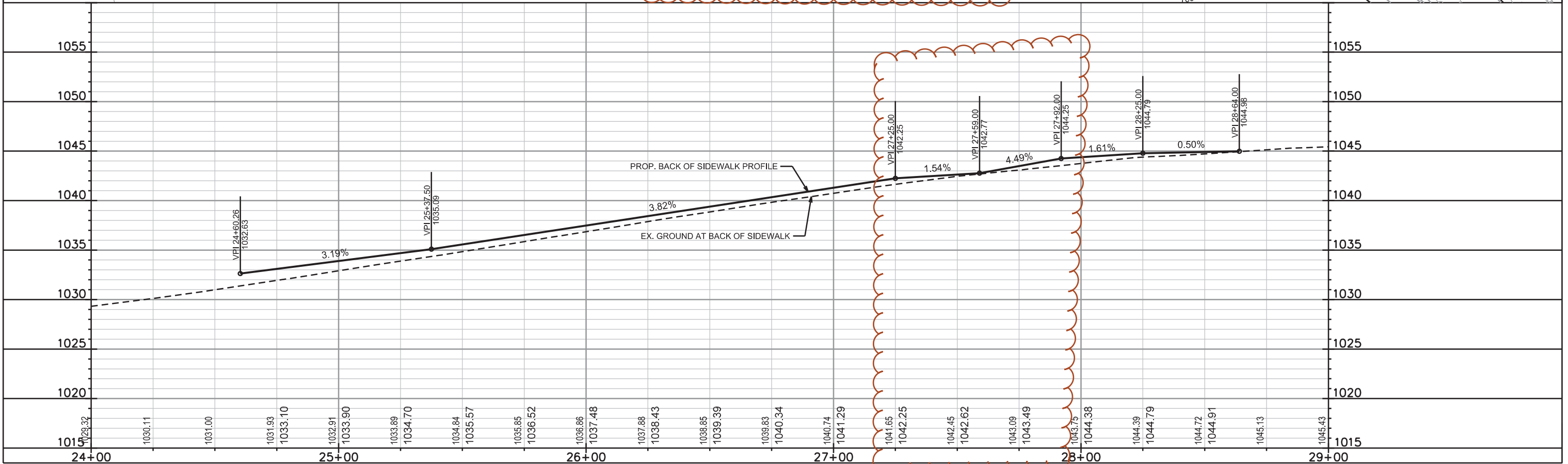
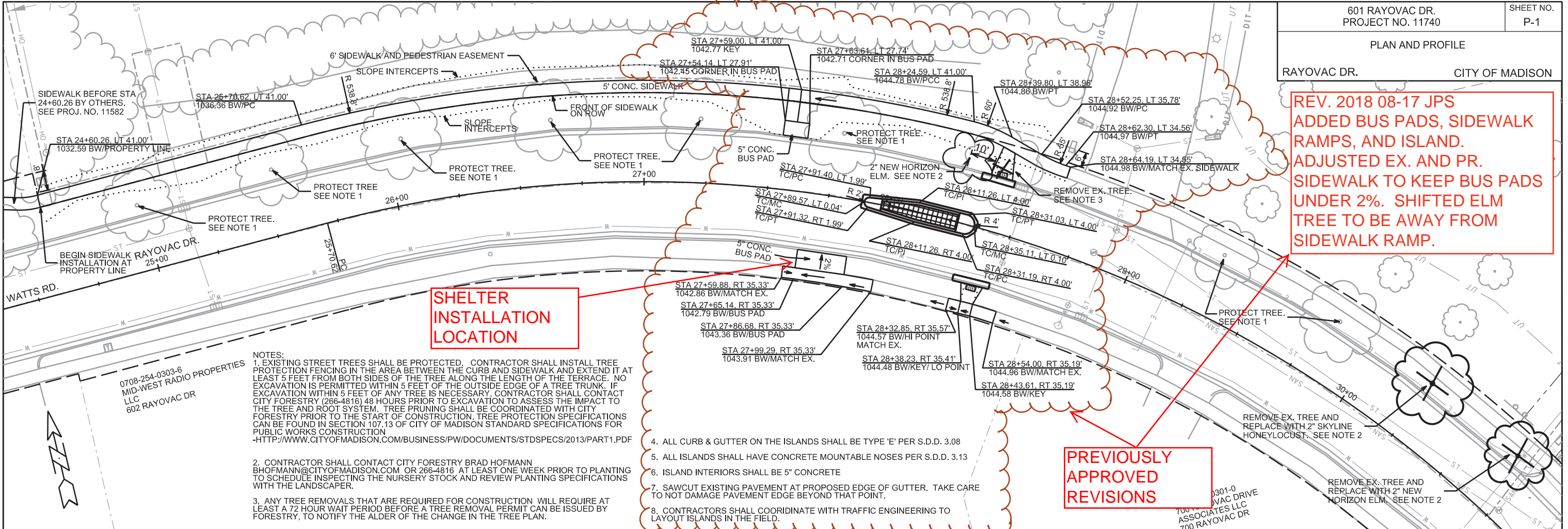

PLOT SCALE: _____

PLOT NAME: _____

REV. DATE: _____

ORIGINATOR: CITY OF MADISON, STREETS DIVISION

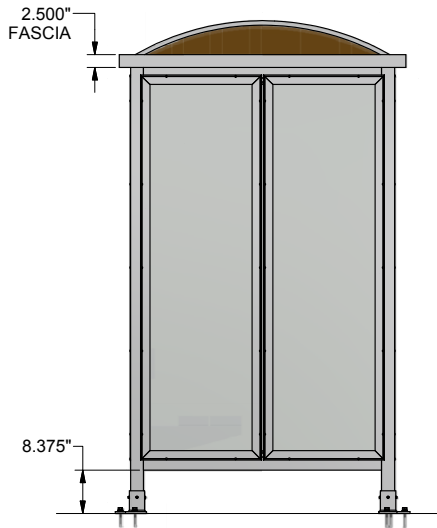

SIDE ELEVATION

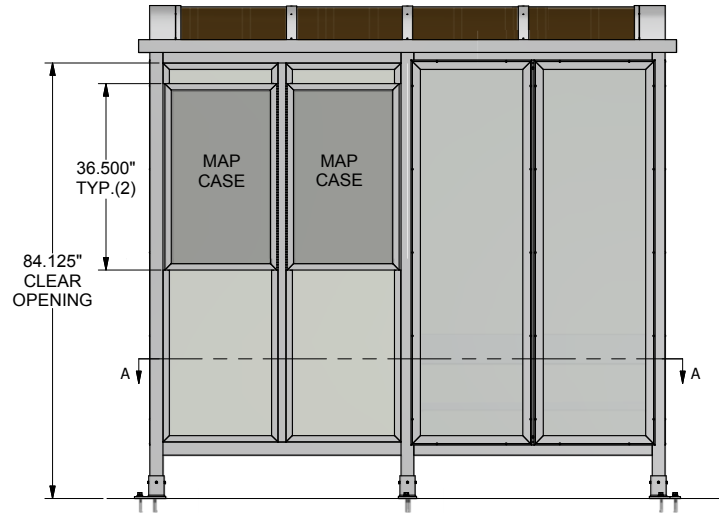

FRONT ELEVATION

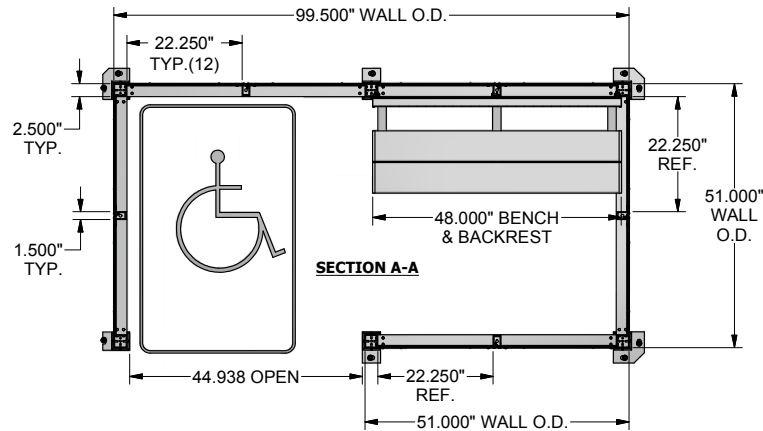

SECTION A-A

THIS DRAWING IS CONFIDENTIAL AND IS FOR THE SOLE USE OF OUR CUSTOMERS AND MAY NOT BE REPRODUCED OR COPIED WITHOUT WRITTEN PERMISSION FROM BRASCO INTERNATIONAL. LEAD TIME BEGINS UPON RECEIPT OF SIGNED APPROVAL.

SIGNED: _____ DATE: _____

QUANTITY (1) SHELTER THUS

SPECIFICATIONS:

- DARK BRONZE ANODIZED ALUMINUM STRUCTURE
- 1/4" CLEAR TEMPERED SAFETY GLASS
- (2) 22 1/4" x 36 1/2" MAP CASE
- 4' ALUMINUM BENCH WITH BACKREST
- 6mm BRONZE STRUCTURED POLYCARBONATE BARREL VAULT ROOF WITH FASCIA/GUTTER SYSTEM



BRASCO INTERNATIONAL, INC.
 32400 INDUSTRIAL DR.
 MADISON HEIGHTS, MICHIGAN 48071
 1-800-893-3665 WWW.BRASCO.COM

THIS DRAWING IS CONFIDENTIAL AND IS FOR THE SOLE USE OF OUR CUSTOMERS AND MAY NOT BE REPRODUCED OR COPIED WITHOUT WRITTEN PERMISSION FROM BRASCO INTERNATIONAL.

CUSTOMER:	MADISON METRO TRANSIT	DESIGNER:	HAUS	CHECKER:	BDH
PROJECT:	SLIMLINE STYLE TRANSIT SHELTER	DATE:	5-7-18	DATE:	5-17-18
MODEL:	SL-04-08-WR-F14-GC-BV30-PTB	JOB #	5403	SHEET:	001
		REVISION:			A

Brasco International

32400 Industrial Drive
Madison Heights, MI 48071

Phone # 800-893-3665 cban@brasco.com
Fax # 313-393-0499 www.brasco.com

Invoice

Date	Invoice No.
10/25/2018	47571

Bill To

Ship To
Madison Metro Transit Attn: James Fink Jr. 1101 E Washington Avenue Madison, WI 53703

S.O. No.	P.O. No.	Terms	Due Date	Rep	Ship Date	Ship Via
5403				SL		contractcarrier
Item	Description		Qty	Rate	Amount	
SL-0408	4' x 8' Slimline Series Aluminum Structure Four Sides, Front Windscreen with One ADA Opening Dark Bronze Anodized Finish Barrel Vault Roof with Bronzed Structure Polycarbonate Glazing 2.5" Fascia with Integral Gutter System 1/4" Clear Tempered Glass		1			
SH	4' Wall Mount Aluminum Bench with Backrest Schedule Holder For Rear Wall with 36.5" Overall Height		2			