

Architectural Engineering Consulting

Report



Garver Feed Mill Building Repairs

for

City of Madison

June 10, 2013

Presented By:



1-800-928-8880

Part 1: Overview

- 1.1 Introduction
- 1.2 Executive Summary
- 1.3 Description of Building
- 1.4 Methodology

Part 2: Structural & Envelope Existing Conditions Assessment

- 2.1 Module A
- 2.2 Module B
- 2.3 Module C
- 2.4 Module D
- 2.5 Module E
- 2.6 Module F
- 2.7 Module G
- 2.8 Module H
- 2.9 Module I
- 2.10 Module J

Part 3: Summaries of Stabilization

- 3.1 Module A
- 3.2 Module B
- 3.3 Module C
- 3.4 Module D
- 3.5 Module E
- 3.6 Module F
- 3.7 Module G
- 3.8 Module H
- 3.9 Module I
- 3.10 Module J

Part 4: Synopses

- 4.1 Preservation Plan Concepts
- 4.2 Statement of Probable Costs
- 4.3 Construction Schedule Outline

Part 5: Appendix

- A.1 Sampling Areas and Scope Repairs
- A.2 Sampling/Sounding Log
- A.3 Analysis and Testing Reports
- A.4 Sightline LLC Elevations
- A.5 Glossary

1.1 Introduction

Facility Engineering, Inc. was retained by the City of Madison in the fall of 2012 to develop an analysis of conditions for the Garver Feed Mill structure (Garver Feed Mill hereafter) located on Atwood Avenue in Madison, Wisconsin.

Garver Feed Mill is located within the boundaries of Olbrich Botanical Gardens. Established in 1952, the gardens are owned and operated jointly by the City of Madison Parks Division and the non-profit Olbrich Botanical Society.

The project will investigate and report on the masonry and structural system distress of Garver Feed Mill. The primary focus of this study is (the undertaking of) a condition assessment followed by a stabilization and repair strategy, encompassing all of the major building elements. The study will consist of on-site observations, field and laboratory testing, and analysis in order to provide an accurate assessment of existing conditions and to determine the mode(s) of failure for the masonry and structural systems. Options, strategies, and costs to stabilize and repair the structure will be presented.

The resulting report will be used to aid the City and Olbrich Botanical Gardens in the decision-making process to determine the most cost effective repairs to stabilize the building and allow for a possible contemporary new use.

Stabilization is defined as the act of applying measures designed to reestablish a weather resistant building enclosure and the structural stability of a deteriorated property while maintaining the essential character-defining form and elements that presently exist.

Project Directory

Owner

City of Madison Parks Division
City-County Building, Suite 104
210 Martin Luther King Jr. Blvd
Madison, WI 53703
City of Madison
608 New York Avenue
Madison, WI 53081

Project Lead

Jeanne Hoffman
Facilities and Sustainability Manager
Engineering Division
210 MLK, Jr. Blvd. CCB Room 115
Madison, WI 53703-3342

Project Coordinator

Paul Stauffer
Engineering Division
City-County Building, Room 115
210 Martin Luther King Jr. Boulevard
Madison, WI 5370

Consultant Team

Lead Firm

Daniel (Dan) L. Maki, PE, MASCE
Peter Bloechl-Anderson
Facility Engineering, Inc.
101 Dempsey Road
Madison, WI 53714

Preservation Architect

Charles J. Quagliana, AIA, NCARB
5018 Holiday Drive
Madison, Wisconsin 53711

Structural Engineer

Kurt Straus, P.E.
Structural Integrity, Inc.
7702 Terrace Avenue
Middleton, Wisconsin 53562

Cost Estimator/Masonry Consultant

Ross A. Rehfeldt, LEED AP
Pete Szotkowski, LEED AP,
Vogel Bros. Building Company
2701 Packers Ave
Madison, WI 53704

1.2 Executive Summary

Project Overview

With its history and iconic form, Garver Feed Mill is a recognized historic structure. It is, however, a building that is in need of significant attention. Time has taken its toll both in terms of masonry integrity and structural stability, mostly interchangeably. In general, roofing systems have failed, structural systems are compromised, masonry is deteriorated, fenestration is obliterated or absent, and vandals frequent the building. The building stands essentially vacant and without meaningful purpose.

Garver Feed Mill retains a high degree of architectural integrity from its period of significance, 1931-1941. Yet, as a publicly owned building, it is faced with multiple issues associated with deterioration, underutilization, and questions about potential contemporary reuse.

The City of Madison, WI, is considering the need to stabilize the building and has funded this study to investigate and report on the building's distress. The key reason for the stabilization of the building is the significantly deteriorated conditions of portions of the building.

This report was prepared by Facility Engineering, Inc., whose team includes Charles Quagliana, a Preservation Architect, SightLine, LLC, Structural Integrity, Inc., and Vogel Brothers. This team aspires to help guide the initial stabilization repair and preservation aspects of the proposed rehabilitation of, or reinvestment in, the building.

This report includes an overview of Garver Feed Mill's history, review of existing conditions, and the recommendations, strategies and probable costs to stabilize the building.

Statement of Significance

The Garver Feed Mill (formerly known as Garver Feed and Supply Company) is important for its local significance in the areas of industry and commerce. It represents the maturation of scientific, research-based, centralized approach to the livestock feed industry, and is an important surviving link to the agricultural industry of the Madison vicinity.

Since its construction in 1906, the factory building at 3244 Atwood Avenue has played an important role in the industrial and commercial history of Madison and the thriving farm district surrounding the city. The period of significance related to the Madison Landmark status begins in 1931, when James R. Garver established a feed mill and farm supply business there.

Garver Feed Mill is the best remaining example of a pre-World War II livestock feed manufacturing plant in Madison. As a whole, the building

retains its architectural integrity from the period of 1931 to 1941, when James R. Garver maintained his feed and supply business.

Historical Overview

In the fall of 1905 and winter of 1906, the original structure of what is now known as Garver Feed Mill was constructed and furnished to operate as a factory. In October of 1906, the United States Sugar Company began operating at the location processing sugar beets. The company filed for bankruptcy in 1925 and the factory was bought twice between then and 1926, when the original processing equipment inside was finally dismantled and sold.

After the sugar business failed, Mr. James Russell Garver, owner of Wisconsin Sales and Storage Company, purchased the building in 1929 and established the Garver Feed and Supply Company. The space was significantly altered during the period 1929-1931, when it was converted into a state-of-the-art feed mill to accommodate the production and storage of dairy and poultry feeds. Two upper floors were removed, interior modification made to accommodate milling equipment, and small infill additions constructed.

Approximately two years after Garver's death in 1973, the company, land, and buildings were purchased by Mr. Wayne Wendorf and Mr. James Hatch. By the 1990s, the feed business was in decline, and the underutilized feed mill property was acquired by the Olbrich Botanical Society in 1996 with contributions from private donors and a stewardship grant from the Wisconsin Department of Natural Resources. The Garver Feed and Supply Company business closed in October of 1997.

Since purchasing Garver, Olbrich and the City Parks Division have used the building for storage. Although many ideas for a new use have been proposed, none to date have proved feasible. In the latest effort, the City of Madison sought out ideas for reuse and rehabilitation of the property in 2006-2008. They received three proposals from development teams. Although a team was selected and began planning efforts, the team withdrew support in the spring of 2011 when they failed to reach fundraising goals.

Investigation Methodology

The development of this report was a process involving investigation, research, analysis, documentation, and ultimately the development of recommendations for stabilization and preservation.

Work began with laser-scanning of the building as a means of documenting existing conditions. The laser-scanner is a highly portable device that collects all data that is visible within the line of sight. The scanner is placed in multiple locations around the building, linked together by targets or reference points, to create a full picture of the

structure, inside and out. Once this data is captured, it is processed and converted into electronic drawing files. These drawings took the form of floor plans, wall elevations and building cross sections providing a clear picture of the building to the investigation team.

Initial investigation of existing conditions took place in the fall of 2012 and winter of 2012-2013. The condition assessment was conducted by architectural, building envelope, structural, and construction specialist disciplines of the team. Multiple days were spent on site to observe, discuss, and record conditions. The goal was to document physical spaces and elements, and to assess the current condition of building materials and structure, both interior and exterior. In conjunction with historical research, the assessment helps determine overall condition and the historic integrity of the building.

Limited historical and archival research was conducted in late fall of 2012 and focused on gathering information and photographic images related to the building's history, original construction, and subsequent modifications, occupancies, and significance.

A public meeting was held at Olbrich Botanical Gardens in February of 2013 to educate the public about historic masonry construction and detail the methods that the team used in collecting information regarding existing conditions.

Through multiple work sessions, the team developed and refined a preservation strategy and approach to stabilization. The process of developing final recommendations and proposed stabilization treatments took place during the winter of 2012-2013 and spring of 2013. The effort focused on articulating the scope of work required for stabilization, repairs, and preservation of the structure as a prelude to later rehabilitation and reuse.

Broad Preservation Principles

Garver Feed Mill is a significant cultural resource containing historical and architectural resources worthy of stabilization and eventual preservation. It is recognized by Madisonians as a cogent linkage to Madison's manufacturing heritage and industrial architecture legacy.

The object of historic preservation is to maintain this legacy of the past for future generations and to be good stewards of the built environment. The focus of these broad preservation principles is to balance the needs of the historic structure with those of a modern, functioning, public-use building.

This durable building possesses a strong degree of integrity. The stabilization and preservation of Garver Feed Mill are highly desirable with respect to sustainable goals and good preservation practice, as well as for providing a functional building for the next 50 years.

The key element for a successful stabilization effort will be adhering to National Park Service's Secretary of the Interior's Standards for the Treatment of Historic Properties. These national standards will help guide the work and ensure that the work will not impose an overly adverse impact on the historic context or character-defining features of Garver Feed Mill.

The possible need for partial deconstruction or small alterations was acknowledged early in the study process. The primary axiom for the extent of deconstruction or design of alterations is to protect the integrity of the qualities and character-defining elements that made the property eligible for a City Landmark status. The efforts should minimize the loss of historic materials and elements. Character-defining features should not be damaged, destroyed, or obscured. Even with this goal, some alteration and loss of integrity is unavoidable.

While some modules will be deemed more significant than others it is imperative to understand that some modules rely on others for stability. Simply razing an adjacent module can negatively impact another.

Anticipated Outcomes

This report serves to be informative of the design efforts for the stabilization efforts. This report should also aid in educating stakeholders and the general public about the history, significance, and current condition of Garver Feed Mill.

This report is also envisioned as a tool to stimulate interest in Garver Feed Mill and assist administrators in securing needed funding from a variety of sources.

The analysis of the building for the purpose of repairs was done extracting gravity and wind loads from the current version of the 2009 International Building Code with Wisconsin Amendments.

The work outlined in this report is directed towards providing a sound, serviceable shell. It is not the intent of this report to bring the building into code compliance with any one single type of use such as commercial, assembly, or warehouse. This is left to the City of Madison and retained professional designers of future phases of the work.

1.3 Brief Description of Building

1.3.1 Floor Plan

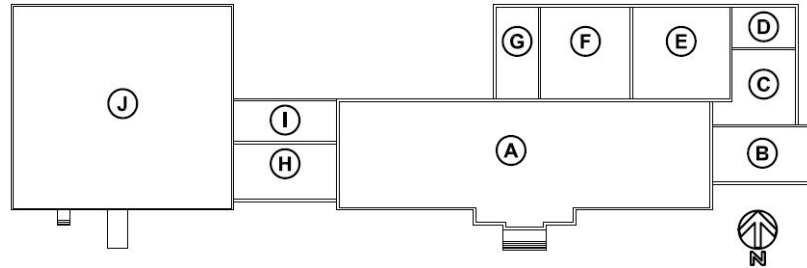

1.3.2 Description

The structure known as Garver Feed Mill is an industrial building consisting of a tall two-story central core (Module A), a west-flanking single-story storage wing (Module J), and east-flanking two-story wings. The building consists of several separate buildings linked together with shared, or “common”, walls. Presently, all of the spaces are vacant except the west wing (Module J), which provides storage for Madison Parks Division materials.

The building extent measures approximately 120 feet by 470 feet. Once a larger and taller structure, Garver Feed Mill presently has ten distinct spaces that remain extant. These spaces have been given designations as illustrated in the floor plan (Paragraph 1.3.1). Within the building, these spaces vary greatly in overall size, number of stories, and story-height. Most of the spaces have generous floor-to-floor heights, some in excess of thirty-five feet. Some regions of the building, including Module A, have tall, soaring spaces open to the underside of their roof structure.

The largest portion of the building volumetrically is Module A, located in the southern half of the building. This was the original engine room and tank-pump area for the sugar beet factory. The length of this portion is approximately half of the total east-to-west length of the building. Its tall, two-story façade is the most prominent, with the entry to the building jutting southward approximately ten feet further than the plane of the rest of the building.

The smallest space is the one-story Module I. This sits within the north side of the building and links the two-story Module A to Module J at the far west of the building. The walls and roof-framing of Module I are a hodge-podge of different framing levels and types, which serves as evidence of the many remodels and alterations that take place within industrial buildings as equipment and needs change.

Several different roof shapes are found on the building. Most areas of the building have nearly flat roofs. These slightly pitched roofs drain water to one edge of the roof. Module D, the old boiler house, was constructed with a steeply pitched gable roof. The roof support structure generally consists of steel trusses supporting wood framing in the large spaces and wood framing for other spaces.

All of the structure consists of brick masonry construction. The wall thicknesses vary from 8" to 20", depending on the sizes and heights of the building. Portions of Module A have decorative corbeling, arched openings for windows, and ledges. All of the building portions have parapets except for Module D with the gabled roof.

The walls are brick masonry. The widths of the walls vary between four and five wythe thicknesses. The change from four wythe to five wythe thickness is mainly derived from the construction of the original building of 1905; no significant modifications appear to have been made in the geometry of the wall construction. Header courses, brick courses that lock the wythes together to form one wall, have several configurations dependent upon the thickness of the wall. The remnants of steel floor beam-ends embedded in the masonry still dot the original construction in the interior space.

Several of the regions have structural floor systems. Some of the structural floors are concrete slabs supported by steel beams and some of the structural floors are wood framing supported by steel beams.

Nearly all of the building portions have slabs-on-grade as their lowest working surfaces. Various portions of the buildings have pits: some smaller and some larger in size. Most of the pits are now partially filled with old equipment and debris. These collect and trap rain and snow melt water.

1.4 Methodology

1.4.1 Survey & Research Types and Methods

Observations

Observations, comments and recommendations offered within this report are based upon the limited condition assessments conducted on multiple days in the winter of 2012-2013. After several walk-through surveys of the entire building, a plan for more detailed investigations was developed. These investigations were performed with the assistance of boom lifts. The assessment team was able to closely observe the exterior and multiple interior spaces within the building, examining extant materials, construction assemblies and conditions. Observations were noted and recorded with field notes and sketches as well as photographs.

The levels of disrepair mentioned throughout the report are described below.

- **Excellent:** Near original condition, all items that can normally be repaired or refinished have recently been corrected. No functional inadequacies of any consequence are evident.
- **Good:** Mostly intact, no obvious maintenance required, little deterioration, retains a high degree of utility and life expectancy.
- **Fair:** Badly worn, signs of wear and deterioration, much repair needed. Deferred maintenance obvious shortened life expectancy.
- **Poor:** Worn out, badly damaged. Significant repair or replacement warranted, numerous functional inadequacies. Excessive deferred maintenance. At the end of useful life.

Structural conditions were reviewed by Kurtis Straus, PE, of Structural Integrity, Inc. The exterior envelope was reviewed by Daniel Maki, PE, and Peter Bloechl-Anderson of Facility Engineering, Inc. Architectural elements were reviewed by Preservation Architect Charles Quagliana, AIA. In excess of 125 man hours were expended for building observations.

The purpose of the limited condition survey was to assess and document the physical condition of readily accessible portions of the buildings and those that could be viewed from adjacent buildings or the ground. Architectural and structural elements were examined to identify their type and determine their condition. Elements open to view were observed. Initial methods were not overly invasive and were non-destructive. Photographs were taken and condition information was recorded in field notes and sketches.

In addition, some destructive testing was conducted at key locations within the building. This included probes of the masonry walls to

determine thickness and composition, verification of construction techniques and to remove materials for sampling and testing.

Research

Research was conducted with two primary sources. These were the Madison Landmarks Commission and Wisconsin Historical Society.

Madison Landmarks Commission provided copies of the Madison Landmarks Nomination forms for the Garver Feed & Supply Company property, dated January 20, 1994. Research conducted at the Wisconsin Historical Society focused on the photographic archives. This included briefly viewing historic photographs in the "Place File".

Review of previous reports and materials included: *Feasibility Study for the Rehabilitation and Adaptive Reuse of the Garver Feed Mill*, dated April 21, 2005 and the City of Madison, Garver Feed Mill Reuse Project web site, <http://www.cityofmadison.com/planning/garver.html>.

Documentation

Drawings illustrating the building are necessary for recording of condition assessment information. Elevations of walls, sections through the building, and floor plans are particularly important. Plans, drawings or records related to original construction were not available and may not exist.

The project team had to develop their own as-built drawings of the building. This has traditionally been accomplished by hand sketching and piece meal measuring of buildings. Due to the large size and condition of the Garver feed Mill, measuring by hand was deemed inefficient and impractical, albeit unsafe in numerous instances.

Laser scanning technology was utilized to acquire documentation and information on existing conditions. This service was provided by Sightline, LLC, of Milwaukee, WI. By using the "hands off" approach of 3D laser scanning, highly accurate information was gathered effectively with only several partial day visits to the job site. This laser scanning technology is highly accurate and captures data with an accuracy of 5mm at a distance of 75 meters.

The laser scanner is a highly portable device that collects all data that is visible within the line of sight. The scanner is placed in multiple locations within and around the building, linked together by targets or reference points, to create a full picture of the structure, inside and out. Once this data is captured it is processed and converted into electronic drawing files.

Within a few weeks of completion of the scans, both 2D drawings and 3D digital files were provided to the project team. These drawings were

used in the condition survey to record field notes, reference photos, and locate probe locations.

The 3-D drawings provided the project team with other valuable information about the building. The most informative insight provided was relative to contours of walls and floors. It became apparent to the team that there was a fair amount of misalignment, distortion, slope and/or bowing of various building elements. This information, coupled with field observations, helped the team discern the overall condition integrity and stability of the structure.

1.4.1.1 Material Sampling

A number of sample regions were made by removing the outer face brick and reviewing the interior of the wall construction. From module to module, the construction appeared to be quite uniform. Overall, the outer wythe bed, head and collar joints were properly full with mortar. The interior wythe construction was much less tightly controlled. Although most bed joints were full, approximately 90 percent, the collar joints were only approximately 50 percent full.

One hundred sixty two sample test probes (openings) were created in the masonry walls. The probes generally consisted of removal of four to six bricks along with some surrounding mortar. The removal was performed with small hammer drills in the mortar to remove enough mortar to free up space around individual bricks. Bricks were loosened with hand chisels.

The information typically obtained from the sample areas was:

- General consistency and quality of mortar in the outer course
- General consistency and quality of brick unit in the outer course
- Integration and integrity of mortar with brickwork in the internal portions of the wall
- Presence of moisture in internal portions of the wall
- Presence of dirt, dust, or organic material in the internal portions of the wall

1.4.1.2 Sounding Investigation

Approximately one hundred sixty 48-inch-square regions on wall surfaces were hammer-tapped or “sounded” to determine how bonded the outer wythe masonry was with the mortar and first inner wythe. Particularly important to the integrity of the wall was the quality and condition of header courses that serve as continuity between wall wythes. The sounding areas were done on the interior and exterior faces of the building at various levels, usually at sampling areas.

1.4.1.3 Header Course Investigation

A single region of both a four-wythe thick wall and a five-wythe wall were investigated to understand the nature of the wall construction (ANL1 and ESL2). Two test areas were created for each, back to back, on each side of the wall. The brick was removed and conditions documented to understand the geometry and level of distress.



Image showing header course construction of four wythe wall.



Image showing header course construction of five wythe wall.

1.4.1.4 Wall Surface Visual Survey

Accessible wall surfaces of Modules A, B, C, E, H, I, and J were surveyed. Interior portions of modules of D, F, and G were partially or completely inaccessible due to safety concerns such as the presence of weak or collapsing floors and roofs, potentially hazard-containing building materials, and loose or hanging overhead debris.

The nature of the survey was intimate using boom lifts operated from ground or floor surfaces. The size, configuration, and effects of wall cracking, masonry pockets, structural bearing for floor and roof members, mortar and brick deterioration, and wall in-plane and out-of-plane movements were recorded in field notes and with digital photography.

1.4.1.5 Roof and Floor Visual Survey

An initial survey was made of all visible structural systems that act as roof systems. Module G was not visible. Several roof systems were obviously damaged beyond saving, such as the roofs of Modules C, D, F, and I.

Several roof systems had obvious damaged and unsalvageable portions but were otherwise worthy of further investigation. The wood framing portions of Modules A and J were observed to be in poor condition, but the associated steel appeared to be in good condition. The wood portions and steel purlins of Module D appeared to be in poor condition, but the riveted steel trusses appeared to be in fair condition.

For the system deemed worthy of further investigation, the configurations, sizes, spacing, and connections were noted and preliminarily analyzed to determine an approximation of their capacities to continue functioning as part of the roof system.

Several floor systems were also visible to review; several were concealed and inaccessible. The floor systems on grade were all observed and assessed with notes and digital photography. Two of the structural slabs, the second floors of Module B and H, were assessed with notes and digital photography. The structural slabs over various pits and first floor of Module H were not accessible. The wood structural floors of Module F were visible but in poor condition, and not assessed. The visible steel and iron portions of the floors of Module F were assessed, but with limited access from the ground due to safety concerns.

1.4.1.6 Spectrographic Analysis

One sample of mortar taken at Module A was sent for analysis to Schmitt Technical Services, Inc., Cross Plains, WI. The sample was tested for compression and bond strength. The sample results were compared to reference mortar samples by Schmidt. From the comparison, judgments

could be rendered about the level of degradation in the strength of masonry.

1.4.1.7 Brick Testing

Multiple samples of brick were taken from Modules A, B, C, D, E, F, and G for the analysis of moisture absorption and compressive strength and were sent to Schmitt Technical Services, Inc. The results were compared to reference brick samples by Schmidt. From the comparison, judgments could be rendered about the level of degradation in the strength of masonry.

Two lots of brick were taken from Module J (south side) to determine the strength of the brick-combined-with-mortar by way of a prism test. The lots were cut and removed from the wall by Dan Forler of B&B Quality Building Restoration, Inc, McFarland, WI, and subsequently tested by CGC, Inc., Madison, WI. The strength results were $f'_{mt}=860$ psi for Sample 1 and $f'_{mt}=730$ psi for Sample 2.

2.1 Module A

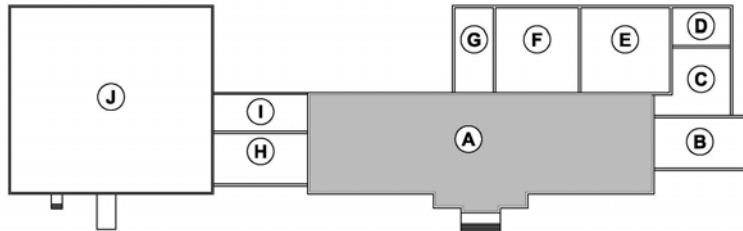

Structural Systems

The building measures approximately sixty-five feet by two-hundred twenty feet, and thirty-five feet tall. The south entry offsets or extends out from the main façade of the building in two staggered bays. The first building bay protrudes south approximately eight feet, the second bay another two-and-a-half feet.

The roof framing is 1x wood decking over 2x10 wood joists over steel beams that frame to steel trusses or other steel main beams. The trusses are supported by the masonry walls; the steel main beams are supported by the masonry walls and cast iron columns (remnants of original construction). Steel trusses and beams designed and placed in 1929 do not align with the strongest sections of the masonry construction of the north wall but do the south wall.



Image showing a view of the underside of the deteriorated wood roof framing at Module A.



Image showing the original 1905 columns of the buildings being adapted to support the 1929 roof beams.



Image showing that the joints in the 1905 columns currently used to support roof structure are braced into the masonry walls.

The foundations are concealed below floor slabs and not accessible to review; however, the original column foundations are likely adequately sized for the current loads since they were originally constructed to carry at least four floors and roof in the original 1905 construction, and are only supporting roof loads in the current configuration.

Rough calculations were performed on several members and trusses with findings suggesting they are capable of supporting roof dead- and live-loads. By inspection, the columns and foundations are also capable of supporting roof loads since, as discussed previously, historically they supported significantly more loads when they were configured to support both floor and roof loads.

The exterior surfaces of the walls have a range of conditions depending on location. The best areas of the wall are addressed as fair with the worst being in poor condition.

The sounding results indicate that there are hollow portions of the wall and the sampling confirmed loose bricks, gaps in the mortar or voids within the wall, all of which will result in a hollow sounding result. Except in the most damaged areas the header courses sounding results were positive and solid.

Typical sampling results on the exterior side of the wall showed that the majority of the damaged brick is within the first wythe of the wall and the mortar damage is within the first two wythes of the wall. The areas with the most damage are the lower six to seven feet of the south

elevation and just below the second story windows. In the most extreme cases the damaged brick is two wythes deep and the failing mortar is within the third wythe. Areas outside of these limits are in fair condition. Refer to Appendix A.1 for limits of damaged areas.

Masonry Conditions

The south exterior elevation of Module A is the predominant façade of the entire building. This elevation has extensive damage to the lowest six-to-seven feet. There is also some damage at and below the stone band and concrete that makes up the sills for the second story windows. Largely, the parapet caps are in good condition with the exception of a region above the main entrance overhead door. The lower portion of the exterior wall is experiencing rising damp and freeze-thaw damage. Rising damp is the result of capillary action of a masonry wall as it absorbs moisture from the ground. At the lowest few feet of the wall the damage is two-to-three wythes thick tapering to one wythe. The damage at the second story concrete band and window sill is due to the missing or damaged windows and the concrete band itself. The flat surface of the concrete is cracked and spalling. This is allowing water to enter the masonry wall and damage the brick courses below and above the band. The damage at the parapet is due to missing or failing parapet caps.

The north exterior elevation of Module A was once an interior wall protected from weather. The adjacent room was damaged by fire and that portion of the building was razed. Given the time that this wall has been exposed to the elements in comparison to the rest of the building it exhibits proportionately more spalling face brick. Perhaps either the fire or the industrial processing had damaged the face brick causing the excessive spalling. The hard face of the brick has spalled and if left untreated will continue to rapidly deteriorate. Along with the outer wythe being in poor condition the sounding of the majority of the wall has poor results. The sampling supported the sounding with those regions containing voids within the mortar. With the exception of the outer wythe and the brick just below the damaged or missing cap stone at the parapet, the inner wythes are solid and in good condition.

The south interior elevation has extensive damage to the lower three feet. This area is adjacent to and associated with the rising damp condition on the exterior side of the wall. The damage to the base of the wall is a result of water pooling against the brick and mortar and freezing and thawing during the colder weather. The interior water source stems from roof failures. There is also some damage at and below the stone/concrete band that makes up the sills for the second story windows. The damage at the stone band and concrete has allowed water to infiltrate the core of the wall and damage the interior mortar opposite to the band.

The north interior elevation is in fair-to-good condition except for the base of wall. The base of the wall exhibits symptoms similar to the south wall: deterioration attributable to rising damp and freeze-thaw.

The east interior elevation is in fair-to-good condition except for the base of the wall. The base of the wall exhibits symptoms similar to the south wall: deterioration attributable to rising damp and freeze-thaw. This wall is not adjacent to an exterior wall but is experiencing rising damp from water pooling against the brick and mortar and cyclic freezing and thawing. The interior water source stems from roof failures. There is also extensive damage below and above the window in this elevation. The mortar below the window sill has eroded and the bricks are loose. No sampling or sounding was performed here due to the vegetation on the exterior wall surface.

The west interior elevation has three critical issues: 1.) the base of the wall exhibits symptoms similar to the south wall: deterioration attributable to rising damp and freeze-thaw, 2.) damage exists below windows, and 3.) there is some significant structural cracking in the southwest corner. This wall is not adjacent to an exterior wall, but is experiencing rising damp from water pooling against the brick and mortar and cyclic freezing and thawing. The interior water source stems from roof failures.



Image showing wall deterioration along its base at Module A.

Several regions of deterioration have advanced significantly to where there exist structural and safety concerns. The roof scuppers and downspouts cease to function correctly, allowing water to infiltrate extensively into the walls. This causes erosion and deterioration due to climatic exposure. One such location is the northeast corner of Module A. The exterior of the building is severely damaged. There is absent brick and mortar in not only the outermost wythe but in the inner wythes

as well. Vegetation has taken root and established itself in the fabric of the wall. The brick and mortar on the interior is eroded and damaged. The extent of the damage is approximately fifteen feet to twenty feet wide by the full height of the wall, or approximately thirty-five feet.



Image showing the nonfunctional downspout at the northeast wall at Module A. Note the vegetation at the wall.

The southwest corner of Module A suffers from apparent structural movement. Several tall cracks have formed between the foundation and the top of the west wall. The cracks are mostly vertical although some stepping was noted. The south wall of Module H connects to this west wall of Module A. The cracking appears on both surfaces of the south wall of Module H. It is also apparent at the south side of the wall of Module H and the north side. It appears that the movement-driven cracking is confined to Module A. The source of the movement is likely related to movements in the foundations. The movement appears to be older as the cracks appear well-established and filled with debris.



Image showing the large cracks in the walls at the southwest corner of Module A.

A region of masonry bearing has some cracking at the western-most end of the three long-span trusses. The cracks are located in the return wall of the south wall near the now-common entry of the building. The shape of the cracking is mostly vertical and is approximately eight feet to ten feet long. There is a smaller crack below, at the bearing of a steel beam from the original 1905 construction. Perhaps the cracking is one of two conditions or a combination of both.

The first possibility is movement in the foundations related to settlements. A minor settlement could lead to rotation in the west wall that turns the corner to Module H, or return wall. The rotation of the wall is being restrained to some degree by the roof truss. The relatively weak masonry has cracked at the bearing. The upper portions of the wall and the wall to the south of the crack have then allowed continued rotation.

The second possibility is thermal expansion and contraction of the steel in the truss. Since the structure is unheated, from season to season the building materials will grow and shrink with increasing and decreasing temperatures. For a 100-degree change in temperature (for example, 90 degrees in the summer to -10 degrees in winter) the trusses will shrink in length approximately $\frac{1}{2}$ ". Furthermore, if the building was constructed in the spring, the movement in the summer would be $\frac{1}{4}$ " growth but only $\frac{1}{4}$ " shrinkage in the winter. At survey time, the size of the crack appeared to be $\frac{1}{4}$ " in width at its widest point. Repairs made to this crack may only be temporary if the building remains unheated. The crack at the since-removed steel beam of the original 1905 construction

also suggests similar performance since the beam line was at one time continuous from the south wall to the north wall.

Several masonry cracks were noted at steel beam bearing locations. The cracks appeared to be minor and easily repairable. Several other minor cracks were noted in the walls of the building. Loose mortar and gaps were found at the joined edges of infilled masonry openings and the main walls of the building.



Image of a beam bearing into the masonry wall of Module A. Notice the horizontal crack below the beam and the diagonal step crack above the beam to the right.

At least one of the truss bearing castings did not appear to have contact with the masonry wall over a large portion its surface.



Image showing the gap between the masonry wall and the truss bearing casting.

Roof Conditions

The wood framing of the roof is damaged beyond salvage. The steel framing, however, appears to be in generally good condition, with minor issues. At least three instances of damage are present from what appears to have been falling objects. In one instance, the bottom chord of one truss has bent flanges. This chord has always performed in tension by design, and the bent portions are not likely expected to affect capacity. In one instance, another bent flange was noted at the top of a truss. Although this flange is a compression member, the damage does not sever any portion of the member and the damage is located at a bracing point (the connection of a web member). In one instance, the large trusses have stabilizing elements that engage the masonry walls at their ends, and one of these stabilizers has been damaged, causing its connection to the masonry wall to dislodge.



Image showing deterioration in the wood roof framing.



Image of a bottom chord that has been damaged by falling objects.

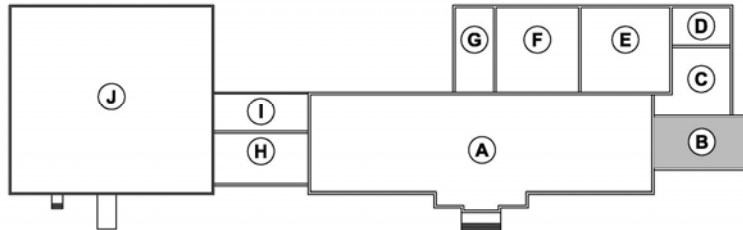

Image of a top chord that has been damaged by falling objects.



Image showing the bent stabilizer from the truss to the masonry wall.

2.2 Module B



Structural Systems

The building is two stories and measures approximately thirty-two feet by sixty feet, and thirty-five feet tall. The west end of Module B is the east wall of Module A.

The walls are brick masonry. The walls are predominantly five wythe in thickness. The structure appears to be original from 1905; no significant modifications appear to have been made in the geometry of the wall construction. Header courses are present in this wall construction as in Module A. Samples were created by removing the outer face brick and reviewing the interior of the wall construction. Reference 1.4.1.3 for comments on header construction, bed, head and collar joints.

The roof framing is concrete over steel beams (similar to Module H). Access was denied to the entire roof underside by the presence of a dropped ceiling; however, observations were made into the space by lifting ceiling tiles.

The second floor is similar to the roof framing. The steel beams run north-south and support a reinforced concrete slab.

The first floor appears to be slab on grade. The thickness of the slab is not known.

The foundations are concealed below floors and not accessible to review.

The masonry structure for the most part is stable and performing as intended. One significant structural problem was noted. A structural

crack exists in the building exterior. This crack appears to extend through the entire thickness of the wall; efforts to verify were denied due to the presence of interior finishes.

Rough calculations were performed on several framing members and trusses with findings suggesting that the floors are capable of supporting assembly live loads and the roofs of supporting current snow loads.

The floor system of Module B is in generally good condition. The slab appears to be functioning as intended with little or no deterioration or existing damage. The beams that support the slab also appear to be in good condition. The beams appear straight with little or no surface corrosion. The beam bearing at the walls also appears to be in generally good condition. The capacity of the floor cannot be determined within the limits of scope of this project. The floor system likely has enough capacity to support the original use of office, commercial, or even industrial space.

Masonry Conditions

The upper level interior space contains good masonry elements but contains missing or damaged windows.

Like Module A, the exterior surfaces of the walls have a range of conditions depending on location. The best areas of the wall are in good condition and the worst are in poor condition.

The south exterior elevation of Module B is also part of the predominant façade carrying the same architectural detail from Module A. This elevation has some extensive damage to the lowest six-to-seven feet. There is also some damage at and below the stone band and concrete that makes up the sills for the second story windows. Largely, the parapet caps are in good condition. The lower portion of the exterior wall is experiencing rising damp and freeze-thaw damage. At the lowest few feet of the wall the damage is two-to-three wythes thick tapering to one wythe. The damage at the second story concrete band and window sill is due to the missing or damaged windows and the concrete band itself. The flat surface of the concrete is cracked and spalling. This is allowing water to enter the masonry wall and damage the brick courses below and above the band. The damage at the parapet is due to missing or failing parapet caps.

The north exterior elevation of Module B, above the roof line of Module C, is similar in condition to the south elevation's second story elements.

The south and east lower level interior elevations have extensive damage to the lower two feet. This area is adjacent to and associated with the rising damp condition on the exterior side of the wall. The damage to the base of the wall is a result of water pooling against the brick and mortar

and cyclic freezing and thawing. The interior water source stems from Module A's roof failures.

The north and west lower level interior elevations have extensive damage to the lower two feet. These walls are not adjacent to an exterior wall but are experiencing the rising damp condition due to water pooling against the brick and mortar and cyclic freezing and thawing. The interior water source stems from Module A's roof failures.

The brick unit masonry generally is structurally stable and performing as intended. Similar deterioration is present at the lowest portions of the walls and at the precast sills of the south and east walls.

Some deterioration of the concrete roof structure is apparent. It appears that some concrete slab is spalling and may present a safety risk to persons in the space below. The damage appeared to be mainly along the existing common wall with Module A.



Image showing poorly performed patches at ongoing deterioration issues at the wall base.

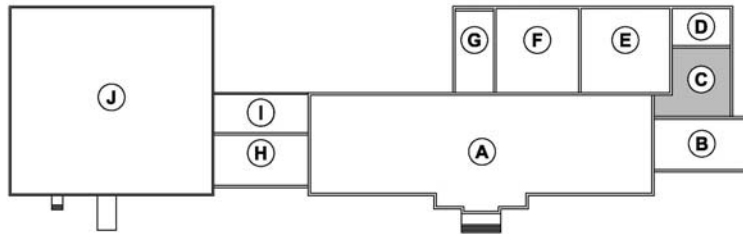

Image showing a stepped structural crack from a second level lintel to the roof.



Image from the north at the second floor northeast corner of Module B. A section of parapet has lost its cap and allowed moisture to migrate into the corner of the building.

2.3 Module C



Structural Systems

The lintels supporting brick above the east wall overhead door openings are damaged by significant exposure to water infiltration from the top of the wall. Despite this issue, the lintels appear to be supporting the brick loads adequately. There is likely some steel corrosion present but not enough at this time to be causing displacement of the masonry.

No exterior sampling and sounding occurred due to the limited material at this elevation. There are structural issues within the masonry in this location and a risk to personal safety.

Observation of the roof structure from the floor below and a lift from above revealed the wood framing is significantly damaged. Some spaces were concealed. The damage affected both the decking and joist framing. The approximate extent of the damage appears to be forty-to-fifty percent of the roof. The extent may be greater since damage to any part of a joist will likely require replacement of the joist along with decking above it. The regions of the deterioration appear to be significant on the west wall. Also, many random instances exist in the center regions and a significant instance along the east edge.

The joists and decking are supported by two lines of shallow wood trusses. The trusses consist of a horizontal beam-like timber, and under-slung metal rods run through the two ends of the timber supported at center-span by a king post. One of the original trusses has since been replaced with a steel beam. The trusses are supported by masonry walls.

The north end of the room is divided by a concrete-masonry-unit (CMU) wall. The CMU wall is helping support the roof trusses.

Three of the four walls of Module C share walls with other modules. The fourth wall, or east wall, contains four overhead door openings with side jambs of precast concrete. A continuous panel of brick masonry exists above the doors to the roof line. The bases of the precast concrete have some minor spalling and cracking.

Masonry Conditions

The interior elevations have extensive damage to the lower two feet. These walls are not adjacent to an exterior wall but are experiencing the rising damp condition due to water pooling against the brick and mortar and cyclic freezing and thawing. The interior water source stems from Module C's roof failures. The west interior elevation is experiencing the most masonry damage due to its location to the failed roof system.



Image showing the east elevation of module C & D.



Image showing the interior surfaces of the east wall. Note the heavy efflorescence and damage to the garage door. The heads of the doors appear to be level and lintels appear to be performing as intended.

Image also shows the damage to the roof decking along the east edge. Note the step in the roof.

2.4 Module D

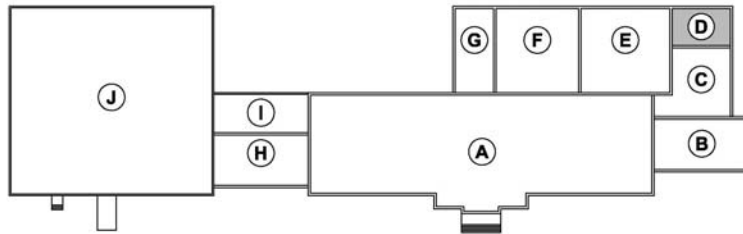

Structural Systems

Module D has a number of significant structural masonry problems.

The majority of the brick unit masonry at the upper courses of the south wall is significantly damaged and falling in sections to the roof below. A section of steel lintel from an opening on the south wall dislodged and is also lying on the roof below. Additional structural damage can be found on the top of the north wall. The nature of the damage is deteriorated mortar and brick, spalling wall sections, and regions of missing bricks.



Image showing a section of the south wall. The extensive masonry deterioration extends at least to the underside of the window openings. Note the missing lintel section at the window opening.

The inside of the walls the thickness changes briefly from a twelve-inch wall to an eight-inch wall. This occurs several feet above the existing plane of the remaining second floor framing. This reduction represents weakness in the wall that could lead to a collapse. The problem is compounded by the lack of integrity of the existing second floor framing. The survey indicated that this back wall appears to bulge outward consistent with early stages of this type of collapse. The magnitude of the bulge is one inch to two inches.



Image showing the north wall, interior side. Note the dark line below the windows. This is the change in wall thickness change from 12" to 8", back to 12"

Minor to moderate through-wall cracks exist at the north and east walls.

Masonry Conditions

The north exterior elevation has extensive damage to the lowest six feet to seven feet. The lower portion of the exterior wall is experiencing rising damp from water pooling against the brick and mortar and cyclic freezing and thawing. At the lowest few feet of the wall the damage is primarily within the mortar. There is some damage at the window sills.

The east exterior elevation has some extensive damage to the lowest six feet to seven feet. The lower portion of the exterior wall is experiencing rising damp from water pooling against the brick and mortar and cyclic freezing and thawing. At the lowest few feet of the wall the damage is primarily within the mortar. There is some damage at the window sills.

The south exterior elevation (above Module C) has extensive damage to the top of wall, due to the completely deteriorated roof system rendering the top and inner wall open to weather. There is some damage at the window sills.

Roof Conditions

Module D's roof structure consists of wood sheathing over wood blocking fastened to steel channels spanning to fabricated steel trusses. The wood framing has been significantly breached by deterioration to the extent that only twenty-to-thirty percent now exists. The blocking nested in the steel channels is also largely deteriorated and the steel channels themselves are significantly damaged. The fabricated steel trusses, however, appear to be in relatively good condition.

The roof of Module D is framed into the side of Module E. The rigidity of this roof into the wall of Module E relies on the rigidity of the masonry joint in the walls between Modules D and E.



Image showing the deteriorated wood sheathing over the blocking nested in the channel purlins, and the fabricated trusses below. The truss bearing ends can be seen exposed in the damaged masonry.



Image showing the bearing ends of Module D's steel channels into the wall of Module E

The floor system of Module D is in poor condition. The wood decking that once covered the joist framing is non-existent. The remaining wood joists are supported by the wall, but the quality of the connections to the wall is non-verifiable due to limited access. Since floor decking is not present, no diaphragm exists for the second floor to help stabilize the masonry walls at that level. As mentioned in the Masonry Conditions, the walls are slender without this support and could be easily destabilized.



Image showing the remaining wood joists of the second floor. No structural diaphragm exists due to the lack of decking. A concrete covered vault is visible at the bottom of the image next to the chimney.

A portion of Module D (from the first- to second-floor) is a CMU vault with a concrete cover. The concrete cover has signs of significant water saturation and some deterioration.



Image showing the underside of the concrete slab over the CMU vault. The stained areas are areas of water saturation and deterioration. The brick masonry at the lower right side is the bottom of the same chimney in the image above.

No interior sampling and sounding occurred due to a risk to personal safety.

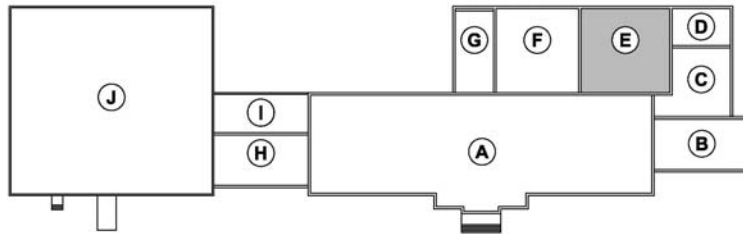

Image showing the top of the north wall. The deterioration appears to be slightly less significant than on the south wall.



Image showing the joint on the north wall between Module D and Module E. The joint is open; the wall of Module D is allowed to move freely from Module E. Unfortunately, the roof of Module D is tied to the side wall of Module E. This type of arrangement can lead to damage in the connections of the roof framing or in the wall masonry. At mid-height of the wall this joint reveals the 1" to 2" bulge in the wall of Module D.

2.5 Module E



Structural Systems

A portion of the roof of Module E share common walls to other modules. The east wall of Module E is common to Modules C & D, the west wall of Module E is common to Module F, and the south wall of Module E is common to Module A.

Long ago, a portion of the roof of Module E was removed to accommodate equipment, and as a result, it has caused interior face brick to be exposed to the weather.

There is a long vertical crack at the south wall of Module E. The crack starts at the roof line and runs the height of the building. The crack appears to initially follow Module E expansion where new masonry was poorly toothed into existing masonry. This poorly toothed joint ends halfway down the wall. The crack varies from 1/8" to 1/2" wide, from bottom to top.



Image showing the poorly toothed joint at the south wall.

Similarly, there is another substantial vertical crack along the intersection of the west wall with the south wall. The entire height of this masonry is believed to be untoothed (a portion of the wall is concealed by the electrical room). There is significant erosion of the brick and mortar along the joint to warrant concern for structural stability.

There are six contributing factors leading to significant concern about the stability of the north wall.

- The survey indicated there is a slight curvature or gradual bulge present in the wall. The undulation is approximately one inch to two inches out of planar.
- This wall is nearly completely unbraced in its height. Other than a connection to the roof at the top, only a couple of poorly constructed and connected trusses brace the wall.
- Historically it was an exterior wall; exterior walls typically see significantly more wind pressures than interior walls.
- This wall has a significant number of window openings. The lack of masonry at the windows detracts from the strength of the wall; while at the same time, covering the openings with plywood causes the maximum wind pressure to contact the wall.
- Water infiltration has caused significant deterioration and erosion of the wall core over a significant region.
- Truss ends in the south wall have cracks around bearing in the masonry. Perhaps the trusses are being pulled out of the south wall by movement of the north wall.



Image showing a truss bearing at the south wall. Note the cracks in the masonry suggesting that the truss is being tugged out of the masonry.

The east and west walls contain similar damage and deterioration but are an improvement over the north wall. They are both mostly interior walls and therefore braced by structure from the opposite sides of the wall (the roof and floor structures of Modules D and F).

Cracks in failed lintels made of brick unit masonry are present at several openings. Cracks also exist at the ends of steel beams, whether functioning or abandoned.



Images showing failed brick arches at a masonry walls, cracking at embedded steel beam ends and eroded masonry at an arched brick lintel.



Images showing failed brick arches at a masonry walls, cracking at embedded steel beam ends and eroded masonry at an arched brick lintel.



Image showing the poorly constructed lintel at the north wall. The steel supporting the masonry only supports a portion of the wall width. The bearing shown at the left is damaged.

Masonry Conditions

The north exterior elevation of Area E has damage at the top of wall, due to missing or failing parapet cap exposing the inner wall to the weather. This elevation also has some extensive damage to the lowest four to five feet. The lower portion of the exterior wall is experiencing rising damp condition from water pooling against the brick and mortar and cyclic freezing and thawing.

The south interior elevation has three critical issues; the base of the wall is experiencing rising damp, there are voids within the wall, and there is significant structural cracking. This wall is not adjacent to an exterior wall but is experiencing the rising damp condition due to water pooling against the brick and mortar and cyclic freezing and thawing. The interior water source stems from the open roof.

The east interior elevation has two critical issues; the base of the wall is experiencing rising damp, and there are voids within the wall. This wall is not adjacent to an exterior wall but is experiencing the rising damp condition due to water pooling against the brick and mortar and cyclic freezing and thawing. The interior water source stems from the open roof.

The west interior elevation has three critical issues; the base of the wall is experiencing rising damp, there are voids within the wall, and there is significant structural cracking. This wall is not adjacent to an exterior

wall but is experiencing the rising damp condition due to water pooling against the brick and mortar and cyclic freezing and thawing. The interior water source stems from the open roof.

The base of the north interior elevation has two critical issues related to deterioration; the base of the wall has extensive damage to the lower three feet and damage at the window sills. The base of wall issue is adjacent to and associated with the rising damp condition on the exterior side of the wall. The interior rising damp condition is also due to water pooling against the brick and mortar and cyclic freezing and thawing. The interior water source stems from the open roof.

Roof Conditions

Access to Module E's roof was limited to review from lifts situated at the interior. The roof structure consists of wood sheathing over wood joists fastened to steel beams and trusses. The wood framing has been significantly damaged over time by moisture. Large holes in the roofing system and structure were observed. The steel framing appears to be unconventional and cobbled. Tall unbraced columns welded at mid-height have little or no load capacity and could be easily destabilized yielding collapse.

In its present configuration, the roof provides little or no diaphragm action to help the module resist wind loads. The interlocked nature of adjacent Modules A and F with relatively intact diaphragms are likely very important to the preservation of the stability of this module.



Image showing tall unstable columns to cobbled roof framing. Note the holes present in the wood sheathing.

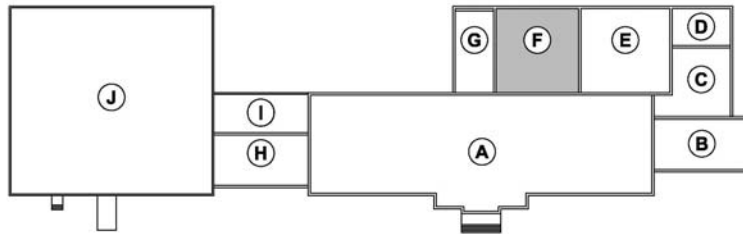

Image showing one of the truss (top) bearing locations. The bottom embedment into the wall appears to be a stabilization point. The rust appears to be only superficial.



Image showing the damaged wood and steel framing bearing into the masonry walls.

2.6 Module F



Structural Systems

Three of the four walls of Module F are common walls to other modules. The east wall of Module F is common to Module E, the west wall of Module F is common to Module G, and the south wall of Module F is common to Module A.

The north exterior elevation of Module F has damage at the top of the wall, due to missing or failing parapet cap exposing the inner wall to the weather. This elevation also has some extensive damage to the lowest four to five feet of the wall. The lower portion of the exterior wall is experiencing rising damp and freeze-thaw damage. There is some damage at the window sills.

Historically, the roof of Module F was removed to accommodate equipment, and as a result, it has caused interior face brick to be exposed to the weather.

The north wall of Module F has significant structural damage caused by water infiltration and seasonal cyclic freezing and thawing. The floor and roof steel beam bearing has been compromised. At least one of the beam ends is dislodged from its original position in the wall.



Image showing the exterior face of the north wall. This image was taken at the second floor level. A beam end behind this masonry is dislodged from its supporting masonry.



Image showing the dislodged beam end at the damaged masonry.



Image showing how deterioration and erosion in the masonry have undermined the integrity of a lintel's bearing.

Masonry Conditions

The south interior elevation has three critical issues; the base of the wall is experiencing rising damp, there are voids within the wall, and there is significant structural cracking. This wall is not adjacent to an exterior wall but is experiencing the rising damp condition due to water pooling against the brick and mortar and cyclic freezing and thawing. The interior water source stems from roof failures.

The east interior elevation has two critical issues; the base of the wall is experiencing rising damp, and there are voids within the wall. This wall is not adjacent to an exterior wall but is experiencing the rising damp condition due to water pooling against the brick and mortar and cyclic freezing and thawing. The interior water source stems from roof failures.

The west interior elevation has three critical issues; the base of the wall is experiencing rising damp, there are voids within the wall, and there is significant structural cracking. This wall is not adjacent to an exterior wall but is experiencing the rising damp condition due to water pooling against the brick and mortar and cyclic freezing and thawing. The interior water source stems from roof failures.

The north interior elevation has two critical issues; the base of the wall has extensive damage to the lower three feet and damage at the window sills. The wall base issue is adjacent to and associated with the rising damp issue on the exterior side of the wall. The interior rising damp condition is also due to water pooling against the brick and mortar and

cyclic freezing and thawing. The interior water source stems from roof failures.

Structural Floor Conditions

Access to all of the floor levels above the first was not possible due to precarious conditions. Observation was performed for the framing of the lowest framed level, or second floor. It is likely that the second floor framing is in the best condition of all of the floors since water leaking in at the roof would initially come in contact with upper floors, thus exposing them to the possibility of more damage. Portions of the second floor systems are in poor condition; other portions appear to be in fair condition.

The decking of the floor system consists of wood joist and decking appears to be damaged. Significant portions of the decking are stained with scattered areas of white mold. Most of the joist framing, however, appears to be in salvageable condition.



Image showing the floor construction of the second floor. The construction is similar at the third floor. Note the white mold on the floor decking near the top of the image. Other than some water staining, a significant quantity of the joists can likely be salvaged.



Image showing the column, beam and joist framing of Module F. Note white mold-covered joists present near the top of the image.



Image looking upwards at the roof framing. The wood framing at the bottom of the image is the third floor. Steel beams and columns support the wood framing.

The steel columns and the steel beam framing all appear to be in generally good condition and can be salvaged.

Roof Conditions

Access to Module F's roof was limited due to the precarious conditions. Access to the topside roof surface was denied due to risk to personal safety.

The roof structure appears to consist of a wire mesh reinforced concrete slab over steel beam framing. This structure is similar to the roof of Module B. It appears to be in poor condition. In one region observed, overhead spalled and dangling concrete debris is evident.



Image showing the underside of the concrete roof from the ground. Obtaining suitable images of issues was difficult due to poor access. A part of the spalled section can be seen as a rusted circular shape between the two roof beams. Note daylight from holes in the roof left from past removal of equipment.

2.7 Module G

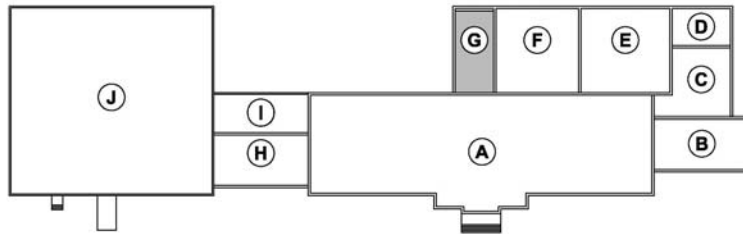

Structural Systems

Two of the four walls of Module G are common walls to other modules. The east wall of Module G is common to Module F, and the south wall of Module F is common to Module A. The interior was mostly inaccessible to our survey due to precarious conditions. The majority of the first floor was deteriorated and partially collapsed into the basement. Access was gained from doorways into the space. The presence of a second floor (there may be a third floor as well) prohibited verification of any interior walls above first floor.

Due to risks to personal safety posed by structural deficiencies there was limited interior access to Module G. Rising damp is an issue in this space and there is damage at the window sills on north elevation.

Masonry Conditions

The north exterior elevation of has extensive damage to the top of wall, due to missing or failing parapet caps allowing water into the inner wall. This elevation also has some extensive damage to the lowest four to five feet. The lower portion of the exterior wall is experiencing rising damp and freeze-thaw damage. There is some damage at the window sills.

The west exterior elevation was once an interior wall protected from weather. The adjacent room was damaged by fire and that portion of the building was razed. Given the time that this wall has been exposed to the elements in comparison to the rest of the building it has seen

proportionately more face brick spalling than the rest of the structure. It is possible that either the fire or the industrial processing used during the building life had damaged the face brick causing the excessive spalling. The hard face of the brick has spalled and if left untreated will continue to deteriorate at an accelerated rate. Along with the outer wythe being in poor condition the majority of the wall had poor sounding results. The sampling results supported the sounding with all areas sampled having voids within the mortar. The lower portion of the exterior wall is experiencing rising damp and freeze-thaw damage.

Roof Conditions

Access to the roof structure and topside roof surface of Module G was not possible due to the precarious conditions.



Image showing the topside of the roof at Module G. The north half of the roof appears to be partially framed with wood.

Access to all of the floor levels of Module F was not possible due to precarious conditions. The framing of the first floor has significant damage. The first floor is in a slow process of collapse into the basement. The collapse appears to be most significant at the edges, away from beam lines suggesting that the beam lines may be intact.



Image showing an area of the first floor collapse. Internal access to this room was not permitted.

Like Module F, the framing of the second level was reviewed from the first floor at the entry doorways to the space. The second floor appears to be mostly constructed of concrete slab and concrete encased steel beams. The condition at the accessible spaces appears to be fair-to-good. Some heavy water-staining suggests that there may be some slab damage.



Image showing a portion of the floor construction of the second floor.



Image showing another region of Module G. This floor system is wood joist covered with a concrete slab. The framing appears to be in good condition.



Images showing a transition from wood joist supporting concrete to reinforced concrete along the walls. The protective cover on the reinforcing mesh has fallen away in some areas exposing the mesh.

The existence, structural system, and condition of the third floor are unknown.

The viewable steel columns and the steel beam framing all appear to be in generally good condition and are salvageable. The column bases supporting the floors and roof likely are exposed to water below the collapsing first floor. Their condition is unknown. Damage to the column bases will likely affect their load-bearing capacity.

2.8 Module H

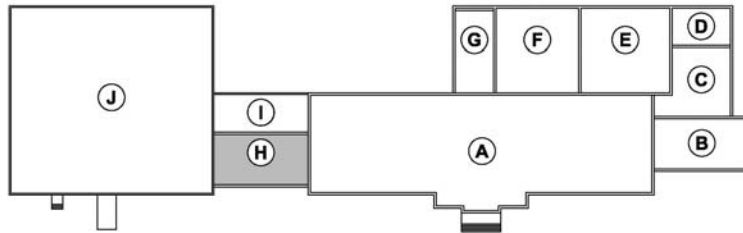

Structural Systems

Module H is a two-story structure surrounded on three sides by other modules. The east wall is common to the tall end wall of Module A, the north wall is common to the single story Module I, and the west wall is common to the single story Module J.



Image showing the upper section of brick deterioration from water infiltration. Large areas of missing brick and mortar can be seen. The

extent of erosion and damage extends out horizontally in the wall several feet away from the center of the source.



Image showing the water damage at the arched brick lintel.



Image showing the interior mortar erosion and brick damage.

The first and second floors are structural. Limited access to the first floor was gained from the outside of the building by removing plywood cover from an exterior opening. The structural system of the first floor appears to be similar to the second floor.



Images showing the construction of first floor. The rusted loop is an old mechanical hanger. The structural slab can be seen as well as a support beam at the left side of the image. Above the hanger loop is the lintel supporting the brickwork above.



The space is a concrete confined pit with skewed walls. The space appears to have been covered in 1929 with steel beams and a reinforced concrete slab. The beams and slabs in this module appear to be in fair condition. Note the brickwork infill around the beams. The bottom of this pit is filled with stagnant water.

The second floor structure of Module H appears to be in generally good condition. The slab appears to be functioning as intended. Minor issues and deterioration exist. The beams that support the slab also appear to be in good condition. The beams appear to be straight with little or no surface corrosion. The beam bearing at the walls also appears to be in generally good condition. The capacity of the floor is not known.



Image showing the topside of the second floor. Steel rails exist embedded into the concrete, possibly acting as reinforcement in the slab. The rails orient diagonally from bottom left to top right in the image. Some of the concrete between these rails was not flush with adjacent concrete. The darker colored area of concrete in this image is just such an instance. This may suggest some damage has occurred, leading to slippage. These regions were not as obvious from the underside.

Masonry Conditions

The south exterior elevation of Module H is also part of the predominant façade carrying the same architectural detail from Module A. This elevation has some extensive damage to the lowest six feet to seven feet. There is also some damage at and below the stone band and concrete that makes up the sills for the second story windows. Largely, the parapet caps are in good condition. The lower portion of the exterior wall is experiencing rising damp and freeze-thaw damage. At the lowest few feet of the wall the damage is two-to-three wythes thick tapering to one wythe. The damage at the second story concrete band and window sill stems from the missing or damaged windows and the concrete band itself. The flat surface of the concrete is cracked and spalling. This is allowing water to infiltrate the masonry wall and damage the brick

courses below and above the band. The damage at the parapet stems from absent or failing parapet caps.

A region of extensive damage exists from top of wall to the base. This section is more deteriorated because a failed scupper exits the wall below the parapet and is funneling water over and through the core brick. A two-story tall region of deterioration on the south wall has advanced significantly to the point where structural stability and risk to safety are concerns. Erosion and climatic exposure-related damage exist. Absent and/or deteriorated brick and mortar is prevalent in not only the outermost wythe but in several of the inner wythes as well. There is significant damage to brick and mortar on the interior surface of this region. The extent of the deterioration is approximately fifteen feet to twenty feet in width and the full height of the wall, or approximately thirty-five feet.

Roof Conditions

Module H's roof structure's review was accessible from the second floor. No access to the topside roof surface was allowed due to risk to personal safety.

This roof construction is similar to the systems found on Modules B and F, but only this roof structure was confirmed (to the south). The concrete roof slab appears to be in generally good condition except for an opening found at the east end. It appears that this opening started out as a penetration for equipment, and exposure to the elements caused the edges of the opening to deteriorate, making the opening larger.

Several other openings in the roof exist due to abandoned equipment.



Image showing the wire mesh-reinforced concrete slab over steel beam roof structure.

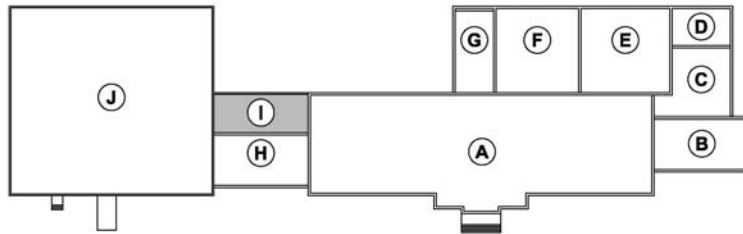

Image showing the bearing of steel beams into the masonry walls.



Image showing the damaged roof slab at the east end.

2.9 Module I



Structural Systems

Module I is a one-story structure surrounded on three sides by other modules. The east wall is common to the side wall of Module A, the south wall is common to the two-story Module H, and the west wall is common to the single story Module J.

The three walls common to other modules are in generally fair condition. The north wall is composed partially of CMU block and partially of brick. The CMU appears to have been replacement for brick. The remaining brick portions are in a range of condition. The brickwork at the top of the wall is in fair-to-good condition; brickwork at the bottom of the wall is in poor condition. An interior bearing wall running north to south divides the space in two and is in poor condition.

The eastern portion or two-thirds of the total space has a floor elevation that matches the elevation of Module A. The western one third of the total space in Module I contains a ramp down to a lower elevation that matches the floor elevation of Module J. The brick masonry wall that divides the space is in poor condition. There is a large four-foot diameter hole in the center of the wall. The doorway next to the void contains damaged and deteriorated masonry. This wall is bearing the roof load. The brick masonry at the void and at the damaged door jamb at the opening is deteriorated with significant mortar erosion.



Image looking east through the building. Note the CMU section of wall.



Image showing the north wall of brick unit masonry. Note the poor condition at the lower section of wall and the relatively good sections of brick near the top of the wall.



Image showing structural damage to the existing interior bearing wall. Besides missing significant sections of masonry, the red areas midway up and the green portions at the bottom are areas found to contain water damage.

Masonry Conditions

The north exterior elevation of Module I was once an interior wall, protected from weather. The adjacent room was damaged by fire and that portion of the building was razed. Given the time that this wall has been exposed to the elements in comparison to the rest of the building it has seen proportionately more face brick spalling than the rest of the structure. Perhaps either the fire or the industrial processing used during the building life had damaged the face brick causing the excessive spalling. The hard face of the brick has spalled and if left untreated will continue to deteriorate at an accelerated rate. A portion of the wall is CMU block and is in better condition than the brick.

The east, south, and west interior elevation are in relatively good condition except for the base of wall which experiences rising damp. This wall is not adjacent to an exterior wall but is experiencing the rising damp condition due to water pooling against the brick and mortar and cyclic freezing and thawing. The interior water source stems from Module I's roof failures.

Roof Conditions

Module I's roof structure's review was accessible from the interior. This module is divided into two sections: an east and a west side. The roof structure of the east end appears to be original. The condition of the roof

is poor. Water infiltrates the structure and has caused extensive deterioration. Several regions of deterioration are collapsing into the space. The affected regions account for approximately seventy percent of the roof framing.

The west end is in good condition but appears to contain relatively new framing. The framing appears to be replacement for damage similar to the east end. Some minor infiltration exists. Several columns have been added to support the newer framing; proper foundations could not be verified.



Image showing the damaged roof sections in the north end of the module. Substantial damage was noted in this region of the module.



Image showing the framing at the west end. This framing is relatively new replacement framing for a section previously removed.



Image showing the west end of the module. Note the two beam lines supported by columns. The sliding door leads to Module J.

The north interior elevation was not sounded or sampled due to the precarious condition of the roof. Visually the brick wall is in poor condition and appears to suffer damage from rising damp and freeze-thaw cycles.

2.10 Module J

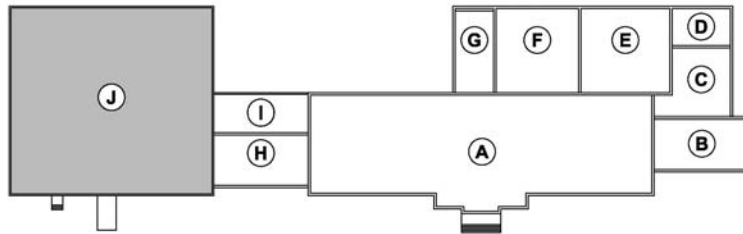

Structural Systems

Module J is a one-story structure sharing a common wall with Modules H and I on its east side.

The north wall is in generally poor condition. The exterior side of this wall contains brick that have significant quantities of spalls. A region of wall at the west end contains significant quantities of absent brick and eroded mortar.



Image showing the region of wall exhibiting absent brick and eroded mortar.

Survey revealed the north wall contains distortions at the east end. The magnitude of the curvature is approximately three inches, concave, from top to bottom of the wall. The maximum amount of change occurs at the base of the wall, fifteen feet from the east corner.

The east wall contains long sweeping curvature along its length. The curvature was detected in survey and observation. It does not correlate to any curvature in the opposing wall. It is unlikely it was intentional. The undulation may be in part caused by wind pressures on the building, shifting the relatively flexible wood roof diaphragm. If so, some wood joists in masonry pockets may have less bearing than originally constructed. Access to verify these pockets was limited.



Image showing the sweeping curvature of the east wall. The sweep appears to be confined to the single story section of the building.

Several cracks exist in the east wall near the north end of Module J. They are step cracks. The cracks, two from the bottom and one from the top, converge to a single point halfway up the wall.

The southeast corner of the east wall, containing some apparent movement, exhibits a tall crack formed from the foundations upward to the top of the wall. The crack is mostly vertical. The south wall of Module H connects to this west wall of Module A. The cracking appears on both sides of the wall, exterior and interior, as well as on the south side of the wall of Module H and the north side. It appears that the movement-driven cracking is attributable to Module A. The source of the movement is likely related to the foundations. Perhaps movement has ceased; the crevice is filled with debris.



Image showing the vertical crack in the east wall at the southeast corner.

The west wall of the structure is in generally fair condition. Approximately half of the interior surface spalling is due to the presence of moisture in the wall and a relatively impervious surface coating that prevents water vapor from escaping. This damage in this wall will worsen and lead to further structural decline.



Image showing one of the access points taken during the survey. The impervious coating can be seen in silver.

The south wall of Module J contains three locations where the bearing for steel beams is compromised. One bearing location receives a crack which emanates from the foundation.

Masonry Conditions

The south exterior elevation has extensive damage to the lowest three feet to four feet. There is also damage at the window sills and top of the wall. The lower portion of the exterior wall is experiencing rising damp and freeze-thaw damage. The damage at the top of wall stems from missing or failing parapet caps.

The north exterior elevation has extensive damage to the lowest five feet to six feet. There is also damage at the window sills and top of the wall. The lower portion of the exterior wall is experiencing rising damp and freeze-thaw damage. The damage at the top of wall stems from missing or failing parapet caps.

The west exterior elevation has extensive damage to the lowest three feet to four feet. There is also damage at the top of the wall. The lower portion of the exterior wall is experiencing rising damp and freeze-thaw damage. The damage at the top of wall stems from missing or failing parapet caps.

The east exterior elevation has extensive damage to the lowest three feet to four feet. There is also damage at the top of the wall. The lower portion of the exterior wall is experiencing rising damp and freeze-thaw damage. The damage at the top of stems from missing or failing parapet caps.

The south interior elevation has extensive damage to the lower three feet. This area is adjacent to and associated with the rising damp condition on the exterior side of the wall. The damage to its base is a result of water pooling against the brick and mortar and cyclic freezing and thawing. The interior water source stems from roof failures. There is also damage at the window sills.

The north interior elevation has extensive damage to the lower four feet to five feet. This area is adjacent to and associated with the rising damp condition on the exterior side of the wall. The damage to its base is a result of water pooling against the brick and mortar and cyclic freezing and thawing. The interior water source stems from roof failures. There is also damage at the window sills.

The east interior elevation, southward, is in relatively good condition except for the base of the wall. This wall is not adjacent to an exterior wall but experiences the rising damp condition due to water pooling against the brick and mortar and cyclic freezing and thawing. The interior water source stems from roof failures. The northern portion of the wall is in worse shape than the southern portion. There is rising damp

at the base of the wall damage to the top of wall and there are structural issues within the wall.

The west interior elevation has extensive damage to the lower three feet, top of wall damage, and face brick deterioration. This region is adjacent to and associated with the rising damp condition on the exterior side of the wall. The damage to the base of the wall is a result of water pooling against the brick and mortar and cyclic freezing and thawing. The interior water source stems from roof failures.

Roof Conditions

The roof of Module J is accessible from the interior. No access to the roof was allowed due to risks to personal safety. The wood framing varies in condition based on location of the survey. There are many regions of voids in the structure. The degradation of the roofing in these regions allows water infiltration to the roof decking and joist framing, causing significant deterioration of same. Approximately thirty-to-forty percent of the roof decking and joist framing is affected. The damage is particularly extensive along the building edge at the parapets.

There is evidence of a past fire; there are a number of charred joists in the south east corner of the module. Several of these joists have been sistered; several that should have been sistered were not. Although the decking in this area has been repaired it has since become a region substantially damaged by water infiltration.

The wood framing is supported by steel beams and columns. The steel beams are in generally good condition. Several columns are damaged; in one case a column had likely been struck by a piece of machinery. The column is bent and approximately six-to-eight inches out of alignment. Subsequently, this column has a fraction of its original load-carrying capacity. In another case, several piers are damaged to the point that they are not adequately supporting their columns and attachments.

The top edge of the east wall at the northeast corner of the module is bowed. Perhaps the diaphragm for this roof was racked as well. Perhaps the joists contain loss of bearing; the presence of newer paint may indicate movement.



Image showing a damaged section of roof. Daylight shines through a void in the roof, along the wall: the region that had experienced fire damage.



Image showing damaged roof decking along the west wall. The decking directly in contact with the wall is deteriorated. Adjacent discolored regions in the decking show the deterioration for a significant distance away from the wall. Many of the joist ends bearing in the wall have decay damage. The concealed topside surface of the decking will likely reveal significantly more damage that what can be seen in images.



Image showing the lapped condition of joists and bearing of a steel beam in the masonry wall.



Image showing the shored end of a steel beam. Perhaps the shore has been added as a precaution in the event of a partial wall collapse.



Image showing the column support at a damaged concrete pier. A portion of the bearing plate is unsupported.



Image showing a damaged roof column. The bend has reduced the load carrying capacity of this column.



Image showing the crack at the beam to the foundation.

Preface

Remedies for distress and deterioration in the construction of Garver Feed Mill become repetitious. On the detail level, actions are many and are similar throughout. These repetitious repairs are required in nearly every module which make up the whole.

Wood, steel, and especially masonry components require significant interventions and repairs. For stabilization, much of the contractors' task will be less specific to the building system than it is to the fundamentals of quality craftsmanship.

Masonry systems repair and stabilization deserve some elaboration due to their complexity. The masonry structure requires five degrees of repair to stabilize the walls. These are: typical repointing or tuckpointing, full depth repointing, one wythe rebuild, two wythe rebuild and full wall depth rebuild.

1. Typical repointing or tuckpointing is the removal of surface mortar to a depth of $\frac{3}{4}$ of an inch and replacing it with suitable mortar in $\frac{1}{4}$ inch lifts. The proper mortar is important; high lime content or softer mortar is most suitable.
2. Full depth repointing involves existing brick in good condition, but the mortar within the first wythe is in poor condition. All the mortar is removed and the existing brick is reused when possible.
3. One wythe rebuilding involves face brick and mortar in poor condition and both require replacement.
4. Two wythe rebuilding involves face brick and second wythe in poor condition and both require attention. In the best case, just the mortar within the second wythe requires replacement; the worst case: the bricks also need to be replaced. Worst case is the common scenario here.
5. Full wall depth rebuild involves wall condition in poor condition throughout the entire thickness of the wall. This level of repair is also required when there is a sizable full depth crack within the wall.

Refer to Appendix A.1.2 'Sampling Areas and Scope of Repairs' for the extent of masonry repairs for all Modules.

Following is a summarization of repairs for stabilization of the structures.

3.1 Module A

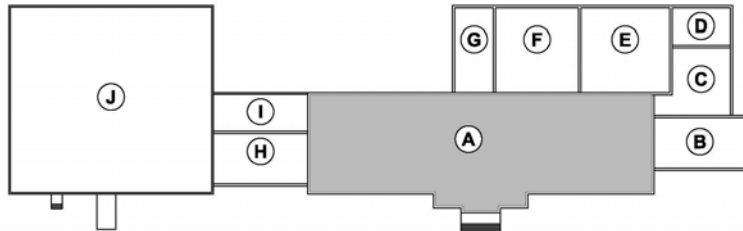

Immediate Needs

Any loose and/or hanging debris of the roof framing shall be removed to reduce the risk to worker safety.

Masonry Recommendations

Refer to Appendix A.1.2 ‘Sampling Areas and Scope of Repairs’ Module A for the extent of masonry repairs.

After stabilization, repoint 100% of the interior and exterior masonry surfaces. Remove the interior paint by stripping with minimal impact to the brick.

Portions of the east wall in the northeast corner shall be repaired by down-stacking with subsequent rebuild. The affected area is approximately 14 feet wide by 32 feet tall. The work shall be toothed into the existing masonry. Repair work will be necessary and accessible from both sides of the wall. Exterior repair work shall match the texture and color of the existing surrounding exterior masonry.

The southeast corner shall be reconstructed due to the presence of a large vertical crack on its east wall. This crack is actually several cracks. The cracks are apparent on both sides of the wall; work will be necessary and accessible from both sides of the wall. The work shall be toothed into three walls existing in Module A and H. Exterior repair work shall match the texture and color of the existing surrounding exterior masonry.

The covers over window openings are failing and should be replaced in kind to help prevent further deterioration of the masonry.

Roof Recommendations

The roof structure shall be replaced. Remove and replace all of the wood framing and decking.

If desired, the distortions found in two instances of damage to the truss chord can be pounded out with steel mauls in the field. The damaged stabilizing element at the end of the western-most truss shall be repaired.

The roofing system is in disrepair and is in need of replacement.



Image showing the exterior of the east wall in the region of the damage.



Image showing the large cracks in the walls at the southwest corner A. The steel channel will be left in place.



Image showing the construction of the existing wood and steel framing.



Image showing deterioration in the wood roof framing.



Image of the damaged bottom truss chord.

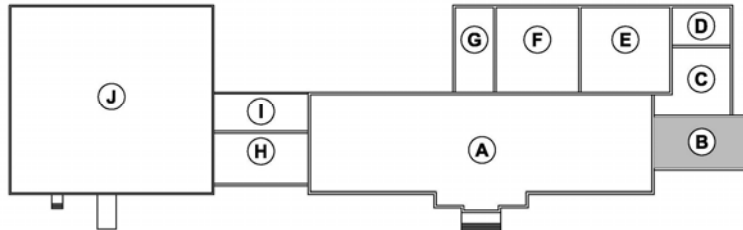

Image of the damaged top truss chord.



Image showing the bent angle at the stabilizer from the truss.

3.2 Module B



Masonry Recommendations

Refer to Appendix A.1.2 'Sampling Areas and Scope of Repairs' Module B for the extent of masonry repairs.

The structural crack above the second floor window opening on the exterior shall be repaired assuming four wythes (two from the exterior, two from the interior). Wood framing will need to be removed to perform repairs on interior two wythes.

The covers over window openings are failing and should be replaced in kind to help prevent further deterioration of the masonry.

Floor Recommendations

Inspect the first floor slab to verify the slab is on grade. If structurally supported, the underside will likely have pits or crawlspace that will need to be considered.

Roof Recommendations

The spalled concrete area noted on the underside of the roof shall be patched.

The roofing system is in disrepair and is in need of replacement.



Image showing the stepped structural crack from a second level lintel to the roof.

3.3 Module C

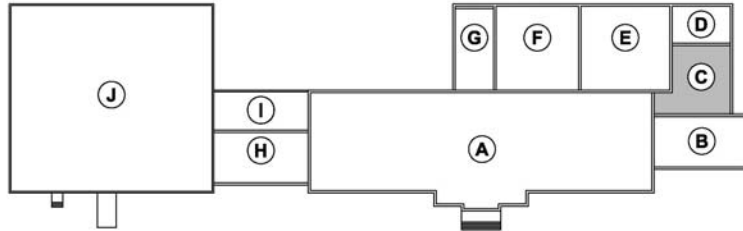

Masonry Recommendations

The CMU walls at the interior shall be removed. These walls appear to be supporting roof loads but do not appear to have footings. This work will need to be performed in conjunction with roof replacement; see Roof Recommendations.

Refer to Appendix A.1.2 'Sampling Areas and Scope of Repairs' Module C for the extent of masonry repairs.

The brick unit masonry above the overhead doors shall be repaired by downstacking with subsequent re-build. Rebuilding the sections offers the opportunity to examine the levels of corrosion of the lintels.

Lintel restoration may be practical.

The concrete jambs between the garage doors shall be patched where spalled.

The covers over window openings are failing and should be replaced in kind to help prevent further deterioration of the masonry.

Roof Recommendations

The roof structure shall be replaced. Remove and replace all of the wood framing and decking.

The ledgers shall be replaced.

The roofing system is in disrepair and is in need of replacement.

Structural Recommendations

The supporting structure consisting of roof beams and columns shall be replaced with steel members.



Images showing the interior and exterior surfaces of the east wall.

3.4 Module D

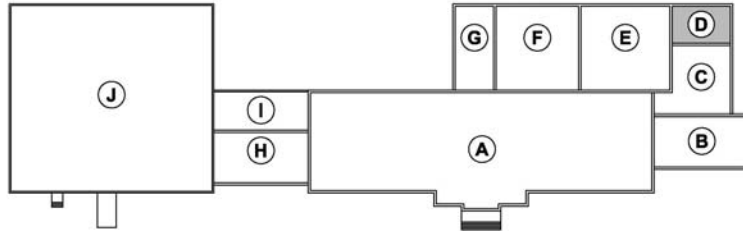

Immediate Needs

The north wall shall be temporarily shored due to its present instability.

Any loose and/or hanging debris of the roof framing shall be removed to reduce the risk to worker safety.

Masonry Recommendations

Refer to Appendix A.1.2 'Sampling Areas and Scope of Repairs' Module D for the extent of masonry repairs.

Twenty-five percent of the north wall and fifty percent of the south wall shall be reconstructed. Existing steel lintels shall be refit into the reconstructed walls. New concrete sills will be necessary at the bases of the windows. Reconstruction shall include the top two feet of sloping masonry at the east wall in order to integrate new support for roof members.

The chimney structure may be considered a source for brick units for this and modules that require matching brick.

Minor-to-moderate through-wall cracks at the north and east walls shall be repaired.

The north wall shall be toothed into the wall of the neighboring Module E; however, since the north walls of Modules D and E are undulating, it may be necessary to pull the north wall of Module D southward prior to completing the tothing.

The covers over window openings are failing and should be replaced in kind to help prevent further deterioration of the masonry.

Roof Recommendations

Remove and replace the wood decking.

Remove and replace the steel trusses.

The roofing system is in disrepair and is in need of replacement.

Structural Floor Recommendations

Remove and replace the structural second floor.

Remove the concrete vault cover and associated single level wall construction.



Image showing a section of the south wall.



Image showing the brick chimney.



Image showing the top of the north wall.



Image showing the joint on the north wall between Module D and Module E.



Image showing the bearing ends of the steel channels into the wall of Module E.

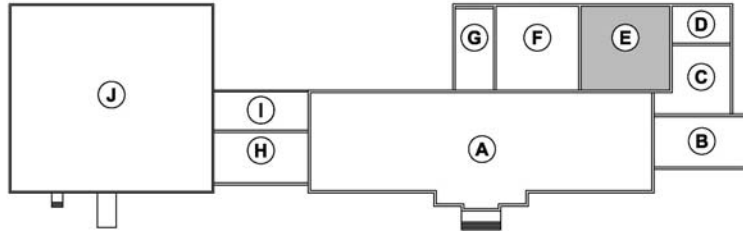

Image showing the existing wood joists of the second floor and the wall transition location 5' above.



Image showing the underside of the concrete slab over the CMU vault.

3.5 Module E



Immediate Needs

The north wall shall be temporarily shored due to its present instability.

Any loose and/or hanging debris of the roof framing and trusses shall be removed to reduce the risk to worker safety.

Sufficient care should be taken when working in the area so that long slender columns supporting the roof are not disturbed.

The pit shall be cleaned and prepared to receive a concrete slab level with the adjacent floor.

Masonry Recommendations

Refer to Appendix A.1.2 'Sampling Areas and Scope of Repairs' Module E for the extent of masonry repairs.

After stabilizing the north wall, up to thirty percent of the north wall shall be reconstructed. The damage is confined (mostly) to the top of the wall. Substantial brick unit masonry replacement will need to occur along the base of the wall.

The top half of the south wall shall be toothed together. The cracked masonry below the joint shall be retooled.

Similarly, the butt-joined west wall shall be toothed into its south wall. The small electrical room shall be removed to access the interface.

Approximately 250 square feet of masonry shall be replaced adjacent to this interface (see elevation drawings).

All cracks that penetrate walls and are visible from both wall faces shall be repaired. The remainder of the cracks shall be repaired by tuck pointing the surface of the outer wythe of brick.

Replace the side jamb masonry at one opening at the north wall and remove the poorly crafted steel support. Masonry shall be toothed to match the adjacent masonry.

The covers over window openings are failing and should be replaced in kind to help prevent further deterioration of the masonry.

Roof Recommendations

Remove and replace all of the wood framing and decking. The walls shall be braced during removal and replacement of the roof. Cross bracing shall be added between trusses. Provide bracing to the masonry walls.

The roofing system is in disrepair and is in need of replacement.

Structural Recommendations

The supporting structure consisting of tall slender columns shall be replaced with steel members.



The arched lintels of brick unit masonry shall be repaired by downstacking with subsequent re-build.



Image showing the poorly toothed interface at the south wall.



Image showing a truss bearing at the south wall. Note the cracks in the masonry suggesting that the truss is dislodged from the masonry.



Images showing failed arched lintels of brick unit masonry, cracking at embedded steel, and brick and mortar erosion



Images showing failed arched lintels of brick unit masonry, cracking at embedded steel, and brick and mortar erosion.



Image showing the poorly constructed steel lintel at the north wall. The steel supporting the masonry only supports a portion of the wall width. The left bearing is compromised.



Image showing tall unstable columns. Note the holes present in the wood decking.

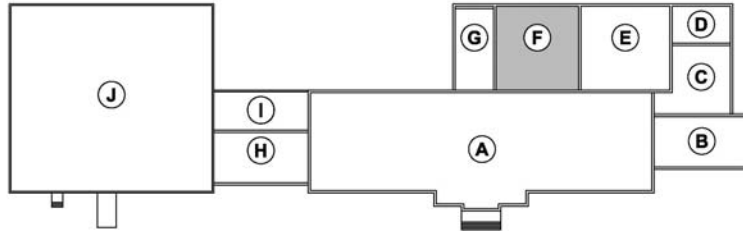

Image showing one truss (top) bearing. The bottom bearing embedment appears to be a stabilization point. The rust present appears to be superficial.



Image showing the damaged wood and steel framing bearing into the masonry walls.

3.6 Module F



Immediate Needs

Any loose and/or hanging debris of the roof framing shall be removed to reduce the risk to worker safety.

The pit shall be cleaned and prepared to receive a concrete slab level with the adjacent floor.

Masonry Recommendations

The recommendations are based on the observable regions of Module F. Access was not possible to the walls of the second and third floor, nearly half of the module.

Refer to Appendix A.1.2 'Sampling Areas and Scope of Repairs' Module F for the extent of masonry repairs.

The extensive through-wall damage on the north wall shall be repaired. The work shall be accessed from both sides. Care will need to be taken to preserve the stability of the wall during the masonry replacement work.

The covers over window openings are failing and should be replaced in kind to help prevent further deterioration of the masonry.

Structural Recommendations

The fallen end of an existing interior steel beam supporting second floor shall be elevated and temporarily supported during the reconstruction of the masonry wall section.

Roof Recommendations

Remove and replace the concrete roof structure; the steel beams shall be salvaged in place.

The roofing system is in disrepair and is in need of replacement.

Structural Floor Recommendations

Remove and replace all of the wood framing and decking of second and third floors. The steel beams shall be salvaged in place.



Image showing how deterioration and erosion in the masonry joints have undermined the integrity of a lintel bearing.

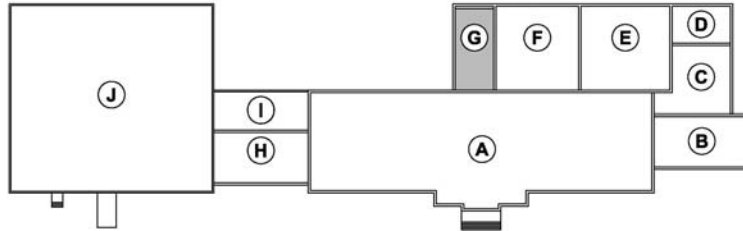

Image showing the exterior face of the north wall. This image was taken at the second floor level. The second floor beam end behind this masonry has dislodged from its supporting masonry.



Image showing the floor construction of the second floor.

3.7 Module G



Immediate Needs

Any loose and hanging debris of the roof and floor framing shall be removed to reduce the risk to worker safety.

The large pit/basement shall be accessed and cleaned. Remove and replace all of the wood framing and decking during this process.

Masonry Recommendations

Refer to Appendix A.1.2 'Sampling Areas and Scope of Repairs' Module G for the extent of masonry repairs.

The recommendations are based on the observable regions of Module G. Access was not possible to the walls of the second and third floors, more than half of the module.

The covers over window openings are failing and should be replaced in kind to help prevent further deterioration of the masonry.

Roof Recommendations

Remove and replace all of the wood framing and decking. The walls shall be braced during removal and replacement of the roof. Cross bracing shall be added between trusses. Provide bracing to the masonry walls.

The roofing system is in disrepair and is in need of replacement.

Structural Floor Recommendations

Remove and replace all of the wood framing and decking at the first floor. Furnish and install new staircase to the pit/basement.

Remove all of the concrete and wood framing at the second and third floors; replace all with wood framing and sheathing. The steel structure shall be salvaged in place.



Image showing the topside of the roof. The north half of the roof appears to be partially framed with wood.



Image showing an area of the first floor collapse.

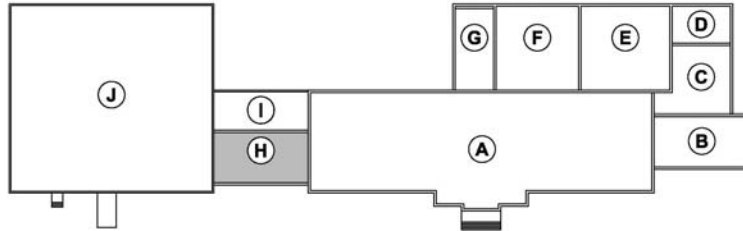

Image showing a portion the floor construction of second floor.



Image showing another region of Module G. This floor system is wood joist covered with a concrete slab.

3.8 Module H



Immediate Needs

Any loose concrete spalling of the roof structure shall be removed to reduce the risk to worker safety.

The pits located below the first floor structural framing shall be accessed and cleaned and prepared to receive a concrete slab level with the adjacent floor.

Masonry Recommendations

Refer to Appendix A.1.2 'Sampling Areas and Scope of Repairs' Module H for the extent of masonry repairs.

Portions of the south wall shall be repaired by downstacking with subsequent rebuild. The affected area is approximately fourteen feet wide by thirty-two feet tall. The work shall be toothed into the existing south wall masonry. Repair work will be necessary and accessible from both sides of the wall. Exterior repair work shall match the texture and color of the existing surrounding exterior masonry.

The covers over window openings are failing and should be replaced in kind to help prevent further deterioration of the masonry.

Roof Recommendations

Existing minor voids in the roof structure shall be covered with metal plates or decking. One larger void shall be repaired with concrete over structural metal decking.

The roofing system is in disrepair and is in need of replacement.

Structural Floor Recommendations

The concrete slab of the second floor shall be removed and replaced where regions are suspected of experiencing weak supports or contain cracking.



Images showing the pits/vaults below the first floor.



Image showing the upper section of brick deterioration from water infiltration.



Image showing the mortar and brick erosion, exterior.



Image showing mortar and brick erosion, interior.



Image showing the minor openings in the roof.

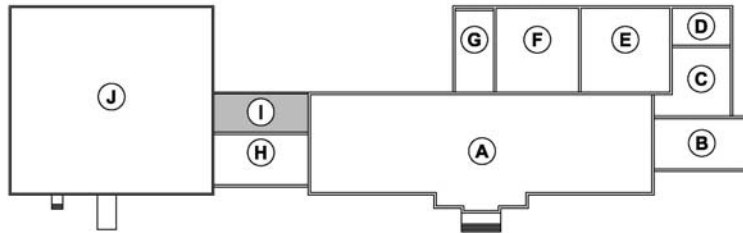

Image showing the location of the 5'x10' roof replacement area.



Image showing a suspected area of poorly placed concrete from the topside of the second floor.

3.9 Module I



Immediate Needs

Any loose and/or hanging debris of the roof structure shall be removed to reduce risk to worker safety.

Masonry Recommendations

Module I masonry shall be deconstructed except to the extent adjacent modules rely on its support.

Roof Recommendations

Module I roof structure shall be deconstructed.

The roofing system is in disrepair and is in need of replacement.



Image of the interior surface of the north wall of the module facing east.

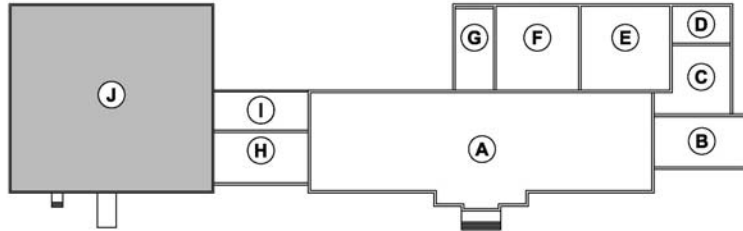

Image of the interior surface of the north wall of the module facing west.



Image showing structural damage to the existing interior bearing wall.

3.10 Module J



Immediate Needs

Any loose and/or hanging debris of the roof structure shall be removed to reduce the risk to worker safety.

Masonry Recommendations

Refer to Appendix A.1.2 ‘Sampling Areas and Scope of Repairs’ Module J for the extent of masonry repairs.

The north wall shall be repaired/reconstructed by downstacking with subsequent rebuild.

The northern half of the east wall shall be repaired/reconstructed by downstacking with subsequent rebuild.

The roof beams supporting the roof system shall be reset into their bearing pockets and the pockets embellished to keep the beam supports stable and positively connected to the masonry walls.

Multiple cracks at the east, south, and west walls shall be repaired with access at both sides of the wall.

The covers over window openings are failing and should be replaced in kind to help prevent further deterioration of the masonry.

Roof Recommendations

Joists along the exterior walls shall be replaced.

All of the joists damaged by past fire shall be replaced with wood members.

The entire roof deck shall be replaced with new decking.

The perimeter of the roof shall receive a new steel ledge.

The roofing system is in disrepair and is in need of replacement.

Structural Recommendations

The damaged columns and concrete support piers shall be replaced with new columns and piers.



Image showing the west end of the north wall.



Image showing the sweeping curvature of the east wall.



Image showing the vertical crack in the east wall at the southeast corner.



Image showing a through wall crack at a south wall beam.

4.1 Stabilization Concepts

Historic properties like the Garver Feed Mill provide substantial links to our past. They contribute to our understanding of the aesthetic, cultural and social values of a particular time period. We find importance in buildings and places that convey historic information about architecture, history, historical figures and historical events.

The Garver Feed Mill is a significant cultural resource containing historical and architectural resources worthy of stabilization and eventual preservation. It is recognized by Madisonians as a cogent linkage to the Madison's manufacturing heritage and industrial architecture legacy, a time when workers lived close to their employers and companies were economic engines for neighborhoods.

Significance

The Garver Feed and Supply Company is important for its local significance in the areas of industry and commerce. It represents the maturation of scientific, research-based, centralized approach to the livestock feed industry, and is an important surviving link to the agricultural industry of the Madison vicinity.

Since its construction in 1906, the factory building at 3244 Atwood Avenue has played an important role in the industrial and commercial history of Madison and the thriving farm district surrounding the city.

The building was occupied from 1906 to 1924 by the United State Sugar Company, a sugar beet processing firm. Since the structure was remodeled circa 1929-1931, it bears only a superficial resemblance to the original structure. Therefore the period of significance related the Madison Landmark status begins in 1931, when James R. Garver established a feed mill and farm supply business there.

The Garver Feed Mill embodies the “coming-of-age” of the livestock feed industry and in the period 1931 to 1941 set the tone for the future of the industry in general.

The Garver mill is the best remaining example of a pre-World War II livestock feed manufacturing plant in the City of Madison. As a whole, the building retains its architectural integrity from the period 1931 to 1941, when James R. Garver established his feed and supply business there.

Garver Feed and Supply reflects the importance of agricultural industries to southern Wisconsin. It serves as a reminder that even Madison, in which government and university activities prevail, is not isolated from the state's agricultural-based economy. (1) *City of Madison landmarks*

Key Issues

The technical aspects of this stabilization, although challenging, are manageable issues with proper research, study and funding. The greater challenge is the orchestration and coordination of stakeholders to develop a census approach for moving forward. The preparation of this report does provide an opportunity to bring diverse stakeholders together, articulate their concerns and reach common goals.

This durable building possesses a moderate degree of integrity (1931-1941 era) as much has been altered in the past, a common reality of industrial buildings that constantly adjust to business and technology changes.

Garver Feed Mill is rapidly deteriorating, yet at present remains durable and adaptable. Action is required soon, however, to save the building as some sections are unsafe and others not presently usable. Stabilization and repair activities will serve both the immediate needs of making the building weather tight and stable and provide for potential future reuse.

The possible need for some deconstruction of portions of the building is acknowledged, especially considering the current state of building deterioration. The primary goal is to protect the qualities and character defining elements that made the property eligible as a Madison Landmark. Any deconstruction should minimize the loss of 1931-1941 fabric, intact historic materials and existing elements. Character defining features should not be damaged, destroyed or obscured. Removed components and materials should be recycled and reused where ever practical.

Preservation is defined as the act or process of applying measures necessary to sustain the existing form, integrity, and materials of an historic property. Work, including preliminary measures to protect and stabilize the property, generally focuses upon the ongoing maintenance and repair of historic materials and features rather than extensive replacement and new construction. New exterior additions are not within the scope of this treatment; however, the limited and sensitive upgrading of mechanical, electrical, and plumbing systems and other code-required work to make properties functional is appropriate within a preservation project.

Integrity is defined as the authenticity of a property's historic identity, evidenced by the survival of physical characteristics that existed during the property's historic period or period of significance.

Stabilization is defined as the act of applying measures designed to reestablish a weather resistant building enclosure and the structural stability of a deteriorated property while maintaining the essential character defining form and elements that presently exist.

Character Defining Features

The original composition was composed of a large main block flanked by smaller support structures, set back of the main façade (tower) to provide visual separation. Although altered, many features remain.

There are various character-defining features visible on the exterior. These include the repetitive segmented arches and corbeled semicircular arches, large window openings, pilasters, stone banding and corbeled parapets. A portion of the once prominent central tower still remains and is important to the overall composition.

The monochromatic brick exterior, semi-circular arch openings for windows and doors, original tower with parapets and horizontal belt or string courses of stone are indicative of this restrained Romanesque revival style of architecture.

The symmetrical balance of the primary façade and generally symmetrical fenestration pattern of windows and doors also contribute to the character-defining features.

On the interior, the character-defining features of the Garver Feed Mill are the large two story open space of the main block, the interior courtyard space and large open storage area on the west. These potentially day-lit areas are unique to Madison as they provide very large open interior space with early 20th century industrial architectural character.

Salvage

Salvage and recycling of existing brick will play a key role in the rehabilitation of the exterior of the Garver Feed Mill. Every day historic buildings, or portions of buildings, are demolished to make way for new development or contemporary additions. But while the structure may have outlived its usefulness, the materials it was made with certainly haven't. Brick is one of the most common building materials recycled in historic preservation projects.

The key reason for this is simply that the beauty of the natural clay these bricks are made from and the aging of these brick over time, is unique. An authentic, time worn, reclaimed brick is impossible to duplicate. Recycled brick also contributes to the greening of projects

through the reuse of existing materials. Used brick also holds historical value and accords greater authenticity.

The removal, cleaning and stacking of bricks is done by hand. The bricks are cleaned of loose mortar and stacked on pallets at the job site. The bricks are then covered in cardboard and then wrapped in heavy duty stretch wrap. Pallets are stored until the bricks are needed for the rehabilitation of the building walls.

Stabilization

Mitigating potential hazards by stabilizing the structure is the first priority. This may include shoring, repair and strengthening of structural components, masonry walls and roofs as well as correcting deficiencies to slow down the deterioration of the building while it is vacant.

It is also very important to protect the exterior envelope from further moisture penetration. Leaks from deteriorated or damaged roofing, from around windows and doors, or through deteriorated materials, as well as ground moisture from improper site run-off or rising damp at foundations, continues to cause long-term damage to interior finishes and structural systems. These must be effectively mitigated.

4.2 Statement of Probable Costs

4.2.1 Stabilization Costs

The work outlined in this report is directed towards providing a sound, serviceable shell. The recommendations in Section 3 outline the work required to stabilize the building shell.

The costs presented are based on Part 3, Summaries of Stabilization, description of repairs for each building module and detailed quantity surveys of the types of repair and specific work required. Subcontractors with expertise and in-depth knowledge of masonry repair of historic buildings were engaged to assess and confirm the costs assigned to each type of repair recommended.

The detailed cost tabulation presents a summary of the stabilization costs by building module. Cost estimate detail for each module includes the description of work, the results of the quantity survey, the unit price assigned to each type of work and the total line item cost.

The base unit costs and project general conditions costs were developed assuming that the entire scope of work would be completed with one mobilization of construction forces. Phasing the repair work over a long period of time requiring multiple mobilizations would add to the cost of the project. Likewise, breaking the project into smaller projects, or reducing the project scope, would result in increases of the work unit costs and the project general conditions.

4.2.2 Restoration

The focus of this report is to identify the level of Stabilization work required. Restoration of the building's walls, roof, and structural systems for a specific use would require additional design and evaluation of current building code requirements for the buildings architectural and structural components. The mechanical, plumbing, fire protection, and electrical building systems scopes of work for the intended building use would need to be defined before accurate costs could be estimated.

4.2.3 Stabilization Cost Summary and Detailed Module Cost Estimate

The following cost report identifies the probable costs for the stabilization and repair work identified in Part 3, Summaries of Stabilization.

Module	Estimated Cost
Module A	\$ 1,240,094
Module B	\$ 159,922
Module C	\$ 134,928
Module D	\$ 143,497
Module E	\$ 549,194
Module F	\$ 419,966
Module G	\$ 316,704
Module H	\$ 285,605
Module I	\$ 134,272
Module J	\$ 1,175,541
Total Est. Cost	\$ 4,559,183

4.3 Construction Schedule Outline

Construction work to implement the recommendations in Part 3 could be completed in six months. This assumes the contractor would procure enough scaffolding to divide the work into three areas. This allows the contractor to minimize the amount of scaffolding required and take advantage of reuse of the scaffolding. The following is a milestone outline for the project construction schedule; many of the milestones would be occurring concurrently and would have overlapping start and finish dates.

Milestone	Construction Duration
1. Award General Construction Contract	Begin Project
2. Building and Demolition Permits	2 weeks
3. Procurement of project materials (brick and mortar)	2 weeks
4. Mobilization	2 days
5. Demolition and Bracing Work Area 1	2 weeks
6. Construct Sample / Test areas for Masonry Repair	2 weeks
7. Restoration Architect and City approval of repair method samples	1 week
8. Masonry Repair work Area 1	2 months
9. Roof replacement work Area 1	1 month
10. Demolition and Bracing Work Area 2	2 weeks
11. Masonry Repair work Area 2	2 months
12. Plumbing and Electrical work Area 1	1 month
13. Roof replacement work Area 2	1 month
14. Demolition and Bracing Work Area 3	2 weeks
15. Masonry Repair work Area 3	1 month
16. Plumbing and Electrical work Area 2	1 month
17. Roof replacement work Area 3	3 weeks
18. Plumbing and Electrical work Area 3	3 weeks
19. Project Clean up	1 week
20. Demobilize	2 days
21. End of Construction	Construction Complete
22. Total Duration of Construction	6 months

Appendix

A.1 Sampling Areas and Scope Repairs

A.1.1 Exterior

A.1.2 Interior

A.1.3 Wall Section Diagrams

A.2 Sampling/Sounding Log

A.2.1 Exterior

A.2.2 Interior

A.3 Analysis and Testing Reports

A.3.1 Schmitt Technical Services, Inc.

A.3.2 CGC, Inc.

A.3.3 Vogel Bros. Building Co.

A.4 Sightline LLC Elevations

A.4.1 Exterior

A.4.2 Interior

A.5 Glossary

Section A.1

Sampling Areas and Scope of Repairs

A.1.1

Exterior

REPAIR KEY	
	REPOINT
	FULL DEPTH REPOINT
	1 WYTHE REBUILD
	2 WYTHE REBUILD
	2 1/2 WYTHE REBUILD
	REPLACE CONCRETE/ SILL BAND
	CRACK TO REPAIR

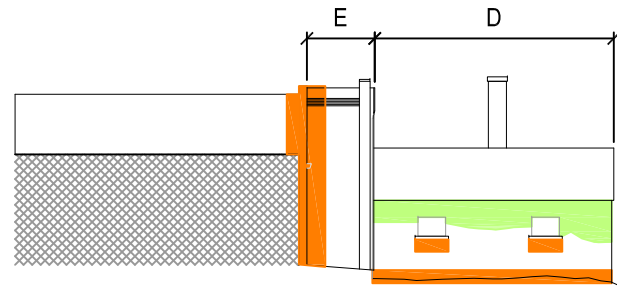

4 SOUTH ELEV. EXTERIOR
Scale: 1/32"=1'-0" SOUTH ELEVATION @D & E

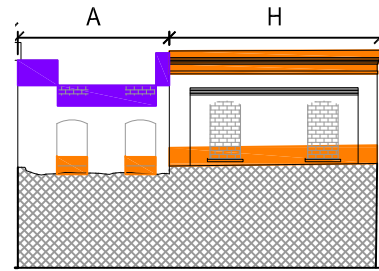

5 WEST ELEV. EXTERIOR
Scale: 1/32"=1'-0" WEST ELEVATION @H & I

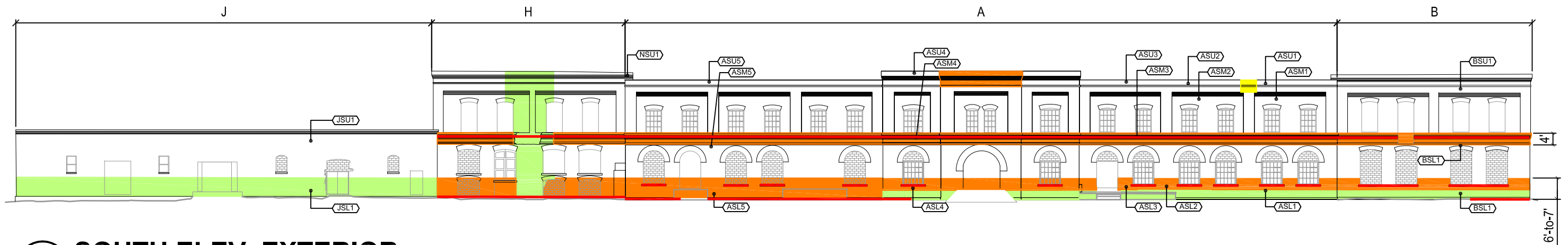

3 SOUTH ELEV. EXTERIOR
Scale: 1/32"=1'-0"

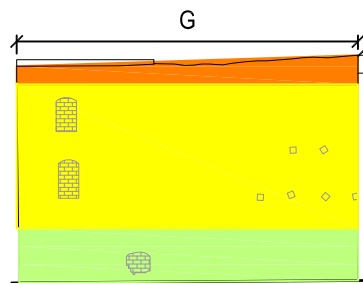

2 WEST ELEV. EXTERIOR
Scale: 1/32"=1'-0" WEST ELEVATION @G

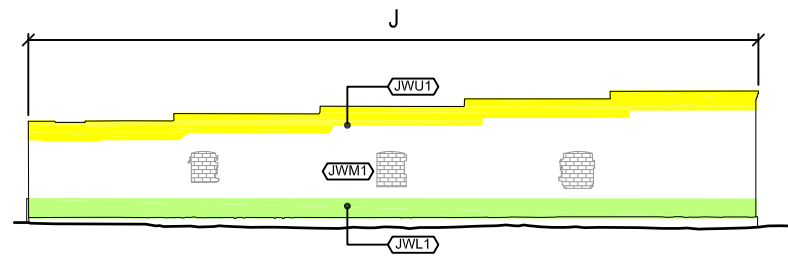

1 WEST ELEV. EXTERIOR
Scale: 1/32"=1'-0" WEST ELEVATION @J

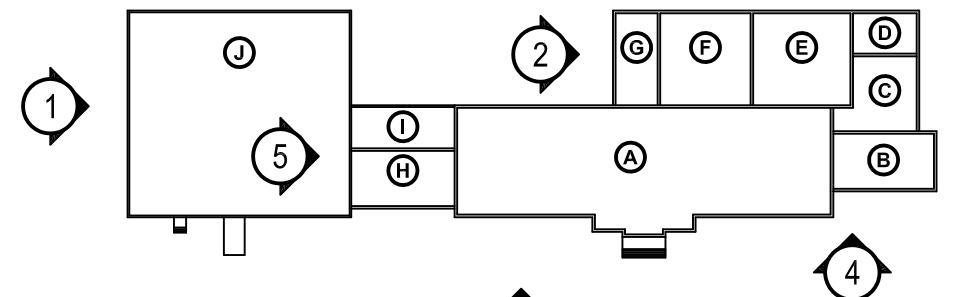

KEY PLAN
Scale: NONE

SAMPLING AREAS AND SCOPE OF REPAIRS: EXTERIOR (1 of 2)

REPAIR KEY	
	REPOINT
	FULL DEPTH REPOINT
	1 WYTHE REBUILD
	2 WYTHE REBUILD
	2 1/2 WYTHE REBUILD
	REPLACE CONCRETE/ SILL BAND
	CRACK TO REPAIR

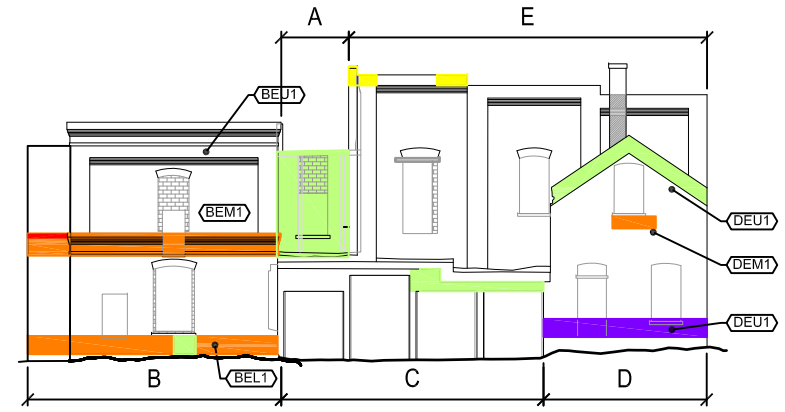

8 EAST ELEV. EXTERIOR
Scale: 1/32"=1'-0"

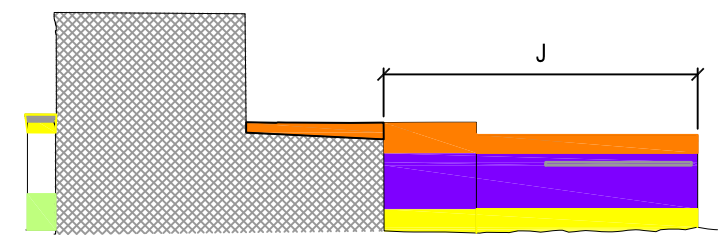

9 EAST ELEV. EXTERIOR
Scale: 1/32"=1'-0"

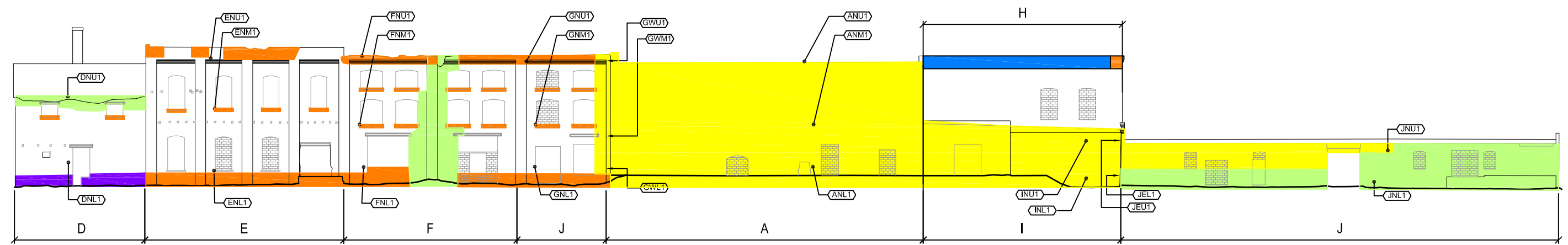

7 NORTH ELEV. EXTERIOR
Scale: 1/32"=1'-0"

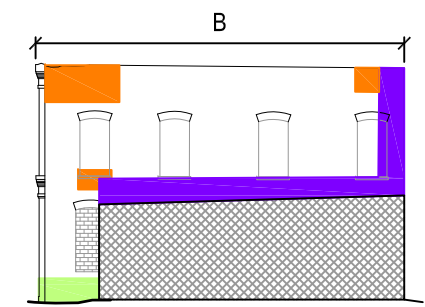

6 NORTH ELEV. EXTERIOR
Scale: 1/32"=1'-0" NORTH ELEVATION @B

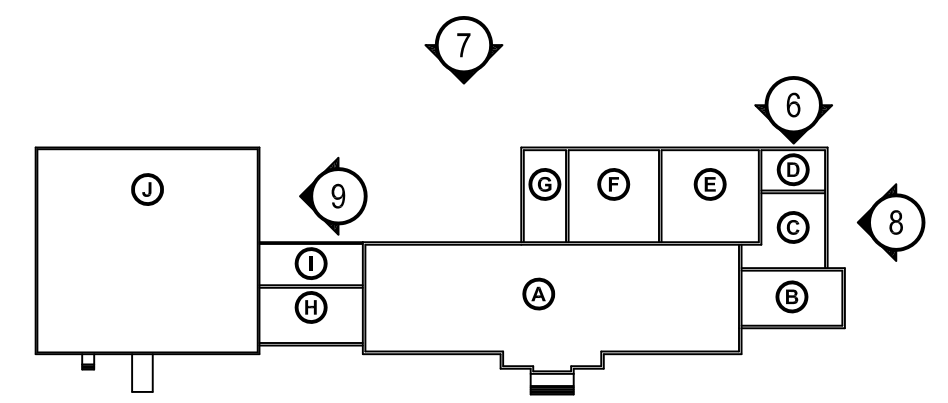

KEY PLAN
Scale: NONE

SAMPLING AREAS AND SCOPE OF REPAIRS: EXTERIOR (2 of 2)

A.1.2

Interior

REPAIR KEY

- REPOINT
- FULL DEPTH REPOINT
- 1 WYTHE REBUILD
- 2 WYTHE REBUILD
- 2 1/2 WYTHE REBUILD
- CRACK TO REPAIR

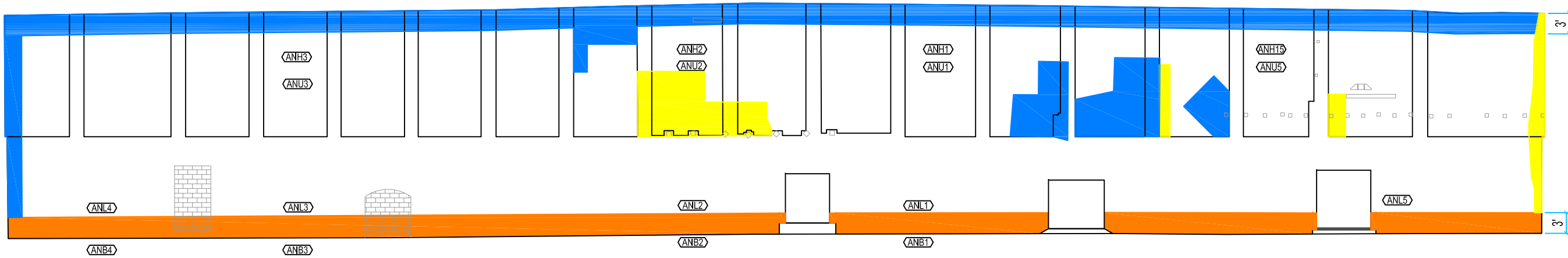

4 NORTH ELEV. MODULE A
Scale: 1/16"=1'-0"

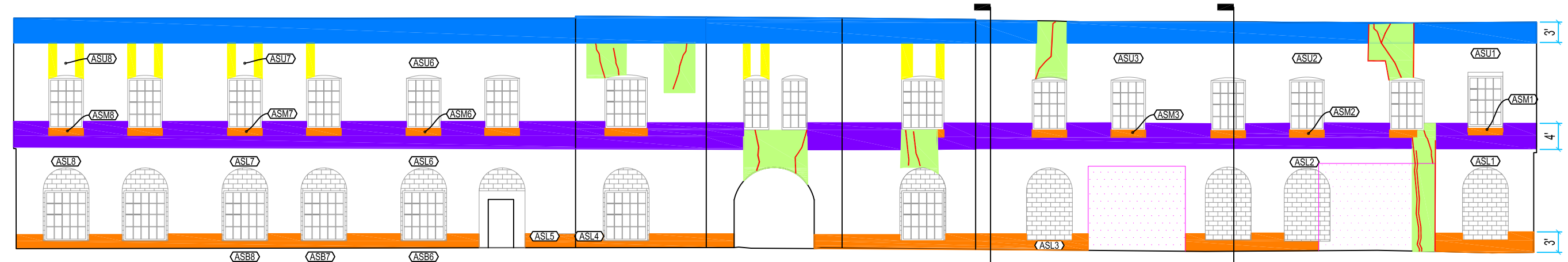

3 SOUTH ELEV. MODULE A
Scale: 1/16"=1'-0"

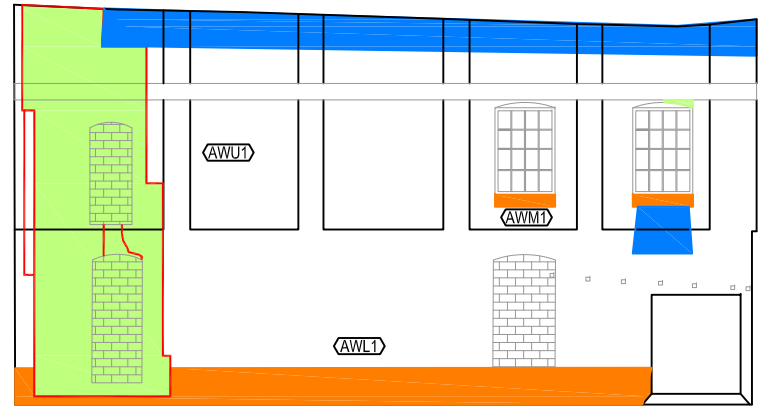

1 WEST ELEV. MODULE A
Scale: 1/16"=1'-0"

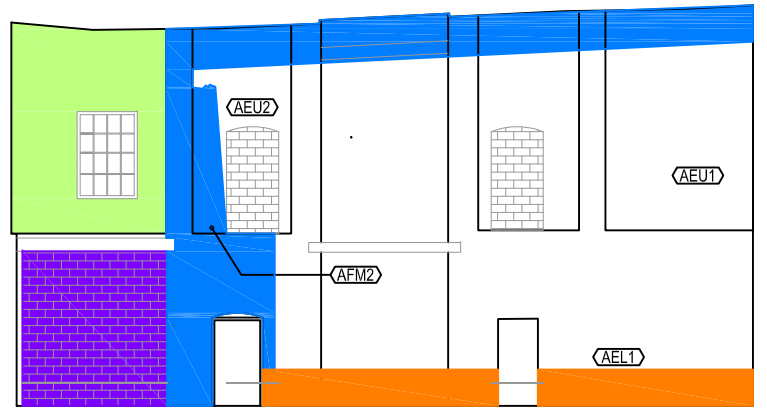



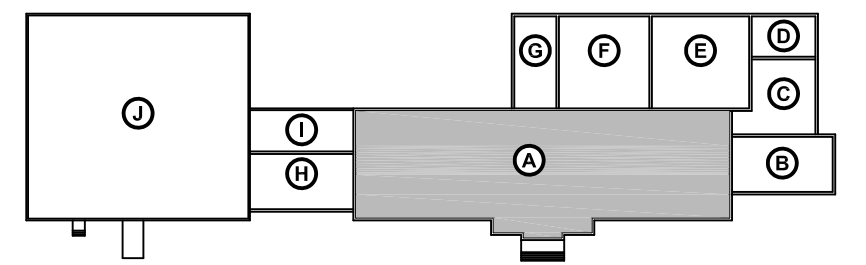



2 EAST ELEV. MODULE A
Scale: 1/16"=1'-0"



KEY PLAN
Scale: NONE

SAMPLING AREAS AND SCOPE OF REPAIRS: MODULE A

REPAIR KEY	
	REPOINT
	FULL DEPTH REPOINT
	1 WYTHE REBUILD
	2 WYTHE REBUILD
	2 1/2 WYTHE REBUILD
	CRACK TO REPAIR

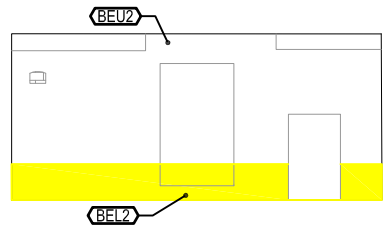

5 EAST ELEV. MODULE B
Scale: 1/16"=1'-0"

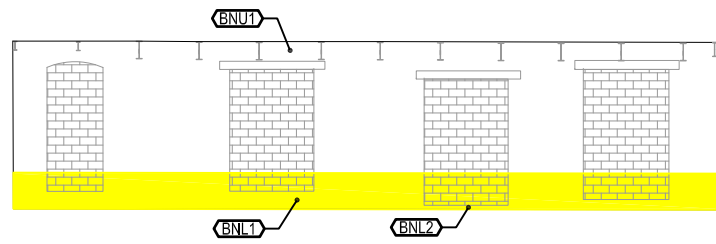

3 NORTH ELEV. MODULE B
Scale: 1/16"=1'-0"

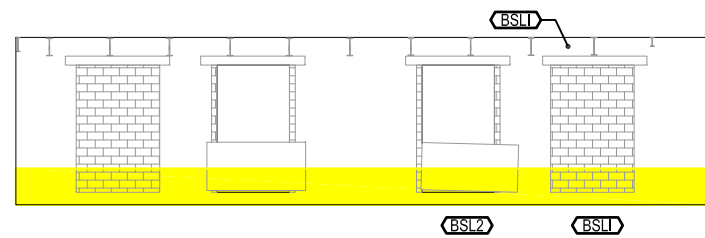

4 SOUTH ELEV. MODULE B
Scale: 1/16"=1'-0"



1 WEST ELEV. MODULE B
Scale: 1/16"=1'-0"

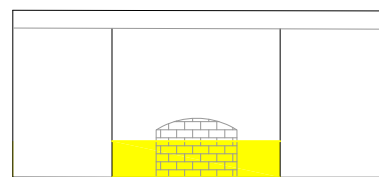



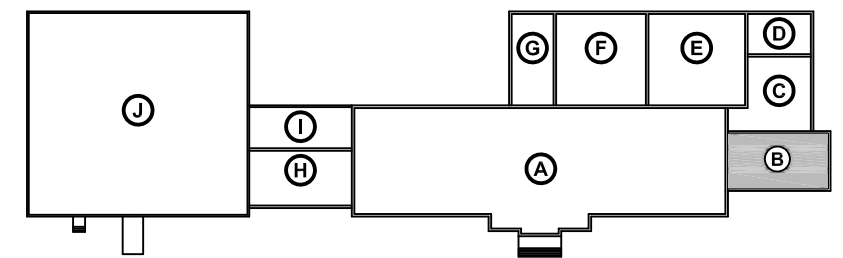



4 MIDWALL ELEV. MODULE B
Scale: 1/16"=1'-0"



KEY PLAN
Scale: NONE



SAMPLING AREAS AND SCOPE OF REPAIRS: MODULE B

REPAIR KEY	
	REPOINT
	FULL DEPTH REPOINT
	1 WYTHE REBUILD
	2 WYTHE REBUILD
	2 1/2 WYTHE REBUILD
	CRACK TO REPAIR

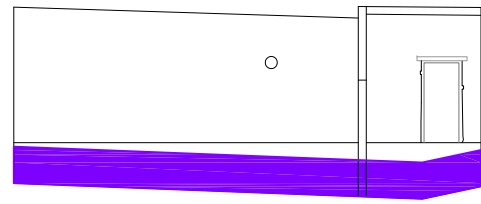

6 NORTH ELEV. MODULE C
Scale: 1/16"=1'-0"

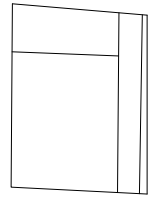

5 NORTH MID-WALL ELEV. MODULE C
Scale: 1/16"=1'-0"

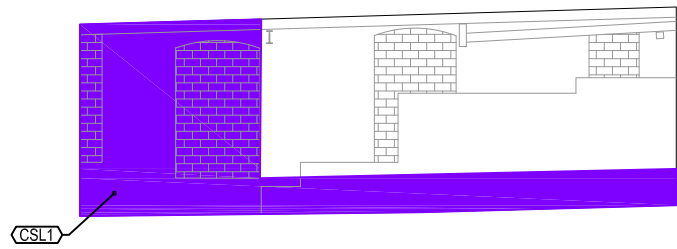

4 SOUTH ELEV. MODULE C
Scale: 1/16"=1'-0"

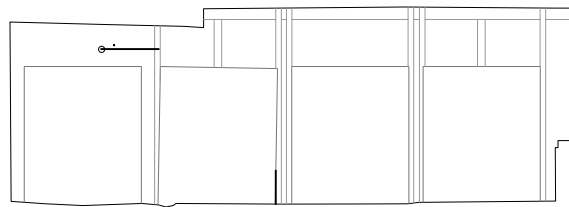

3 EAST ELEV. MODULE C
Scale: 1/16"=1'-0"

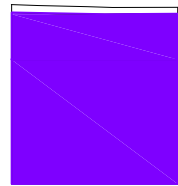

2 WEST MOST ELEV. MODULE C
Scale: 1/16"=1'-0"

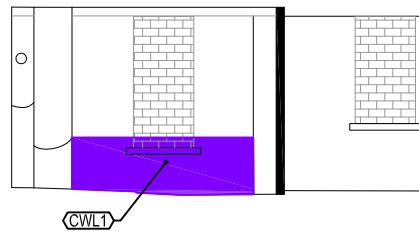



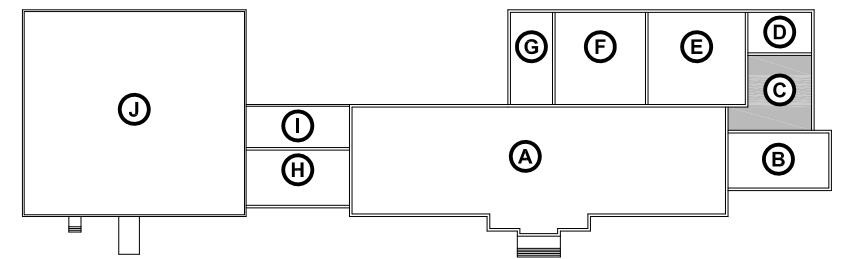



1 WEST ELEV. MODULE C
Scale: 1/16"=1'-0"



KEY PLAN
Scale: NONE

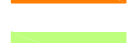

SAMPLING AREAS AND SCOPE OF REPAIRS: MODULE C

REPAIR KEY	
	REPOINT
	FULL DEPTH REPOINT
	1 WYTHE REBUILD
	2 WYTHE REBUILD
	2 1/2 WYTHE REBUILD
	CRACK TO REPAIR

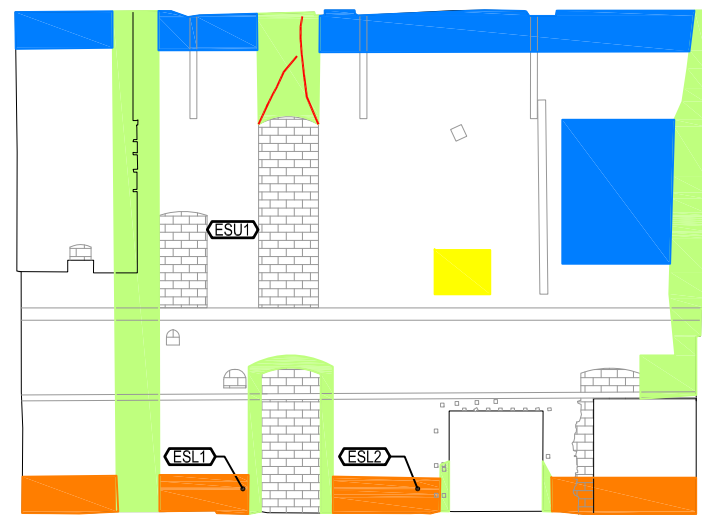

3 SOUTH ELEV. MODULE E
Scale: 1/16"=1'-0"

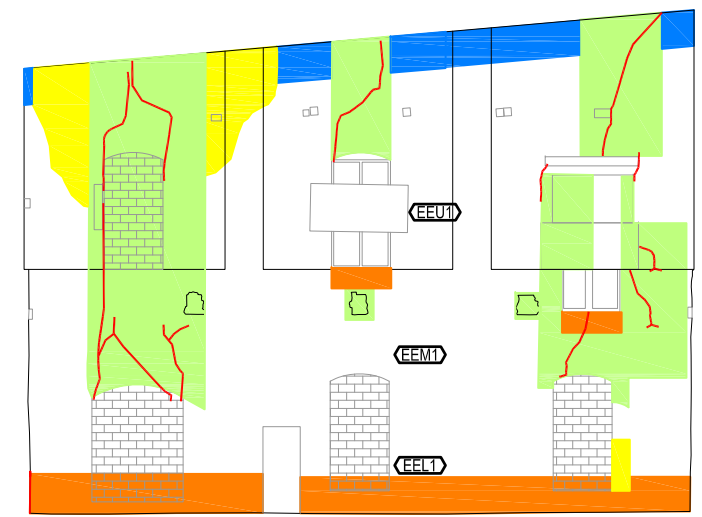

4 EAST ELEV. MODULE E
Scale: 1/16"=1'-0"



1 WEST ELEV. MODULE E
Scale: 1/16"=1'-0"

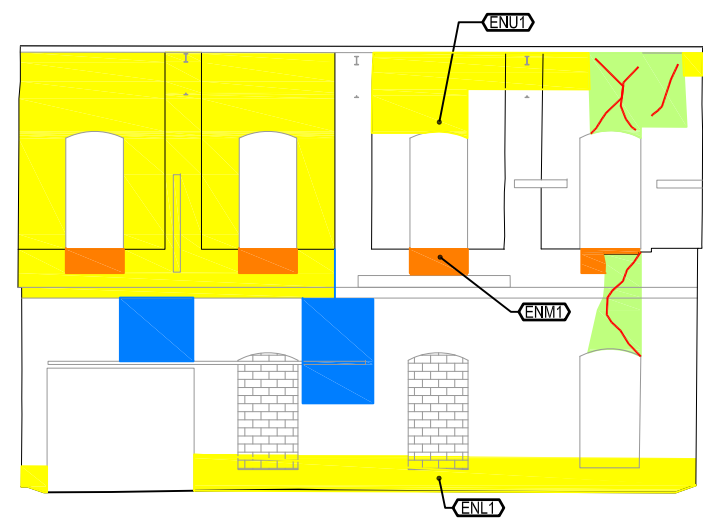



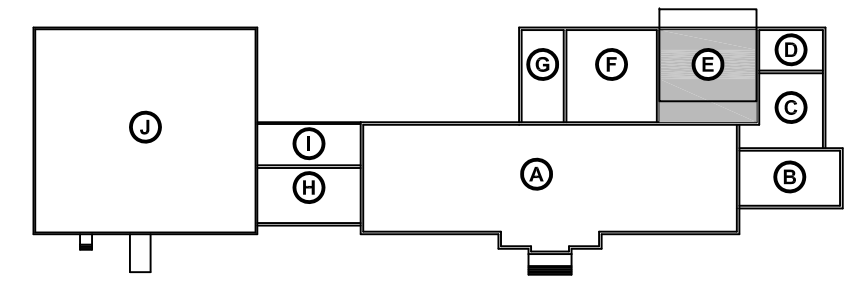



2 NORTH ELEV. MODULE E
Scale: 1/16"=1'-0"



KEY PLAN
Scale: NONE



SAMPLING AREAS AND SCOPE OF REPAIRS: MODULE E

REPAIR KEY	
	REPOINT
	FULL DEPTH REBUILD
	1 WYTHE REBUILD
	2 WYTHE REBUILD
	2 1/2 WYTHE BUILD
	CRACK TO REPAIR



4 NORTH ELEV. MODULE F
Scale: 1/16"=1'-0"

3 EAST ELEV. MODULE F
Scale: 1/16"=1'-0"

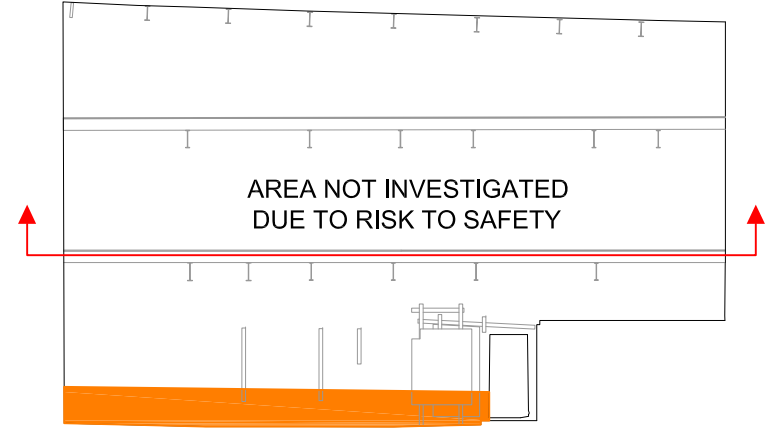

2 SOUTH ELEV. MODULE F
Scale: 1/16"=1'-0"



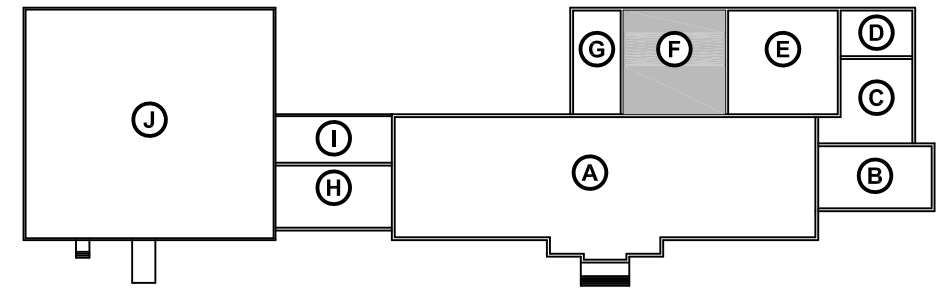



1 WEST ELEV. MODULE F
Scale: 1/16"=1'-0"



KEY PLAN
Scale: NONE



SAMPLING AREAS AND SCOPE OF REPAIRS: MODULE F

REPAIR KEY	
	REPOINT
	FULL DEPTH REPOINT
	1 WYTHE REBUILD
	2 WYTHE REBUILD
	2 1/2 WYTHE REBUILD
	CRACK TO REPAIR

MODULE NOT INVESTIGATED
DUE TO RISK TO SAFETY



4 NORTH ELEV. MODULE G
Scale: 1/16"=1'-0"

3 EAST ELEV. MODULE G
Scale: 1/16"=1'-0"

MODULE NOT INVESTIGATED
DUE TO RISK TO SAFETY

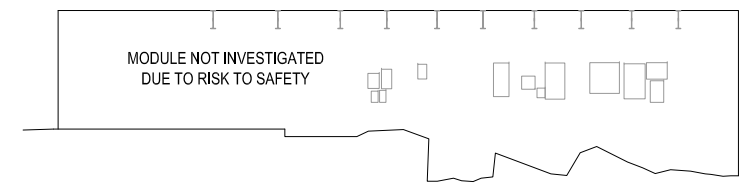

2 SOUTH ELEV. MODULE G
Scale: 1/16"=1'-0"

1 WEST ELEV. MODULE G
Scale: 1/16"=1'-0"

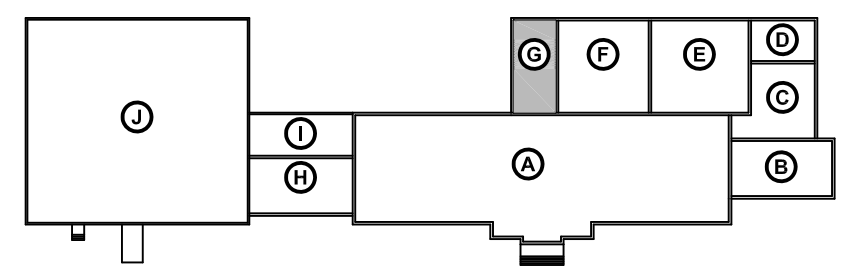

KEY PLAN
Scale: NONE



SAMPLING AREAS AND SCOPE OF REPAIRS: MODULE G

REPAIR KEY

- REPOINT
- FULL DEPTH REPOINT
- 1 WYTHE REBUILD
- 2 WYTHE REBUILD
- 2 1/2 WYTHE REBUILD
- CRACK TO REPAIR

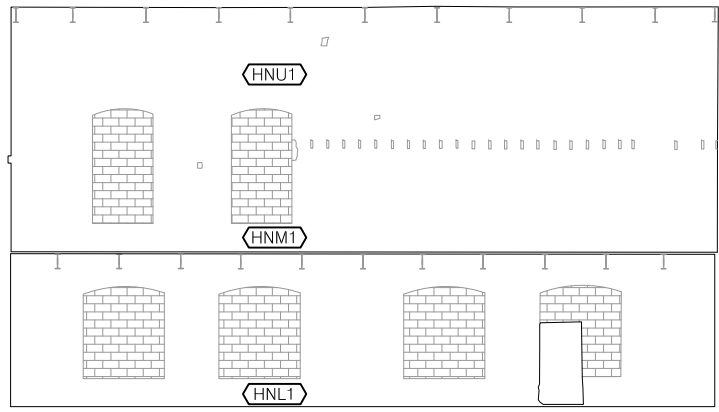

3 NORTH ELEV. MODULE H
Scale: 1/16"=1'-0"

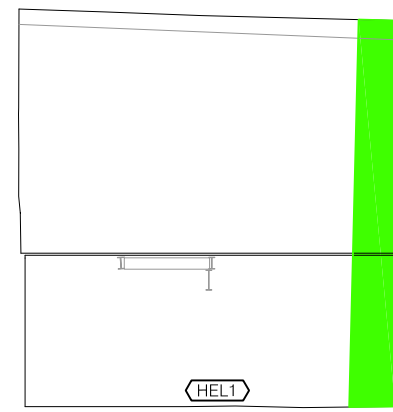

4 EAST ELEV. MODULE H
Scale: 1/16"=1'-0"

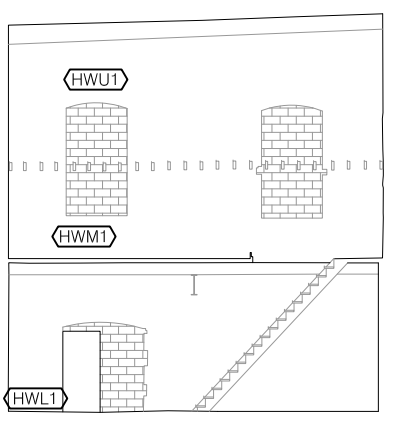

1 WEST ELEV. MODULE H
Scale: 1/16"=1'-0"

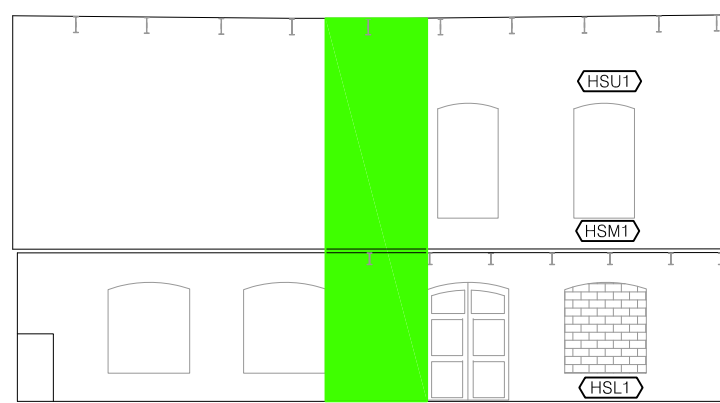



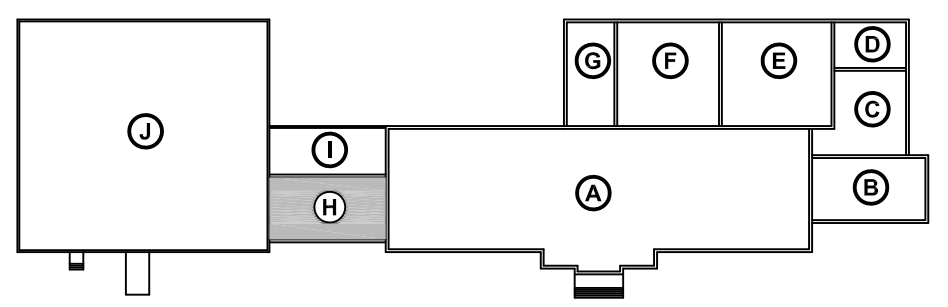



2 SOUTH ELEV. MODULE H
Scale: 1/16"=1'-0"



KEY PLAN
Scale: NONE

SAMPLING AREAS AND SCOPE OF REPAIRS: MODULE H

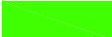
REPAIR KEY

-  REPOINT
-  FULL DEPTH REPOINT
-  1 WYTHE REBUILD
-  2 WYTHE REBUILD
-  2 1/2 WYTHE REBUILD
-  CRACK TO REPAIR

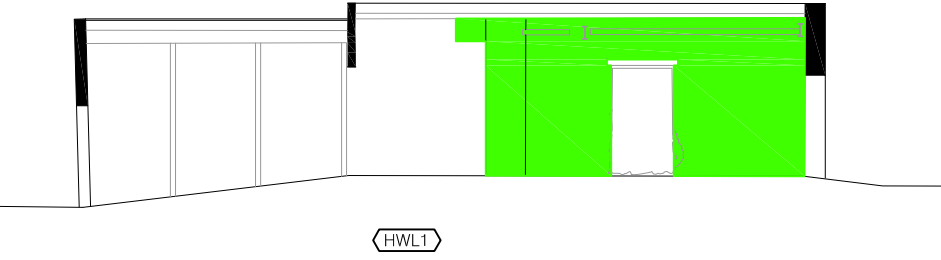

5 NORTH ELEV. MODULE I
Scale: 1/16"=1'-0"

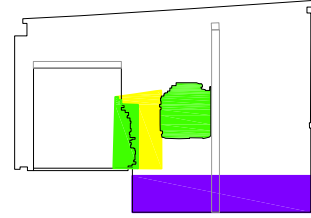

6 MIDWALL ELEV. EAST MODULE I
Scale: 1/16"=1'-0"

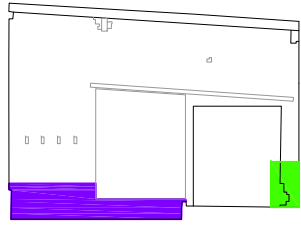

2 WEST ELEV. MODULE I
Scale: 1/16"=1'-0"

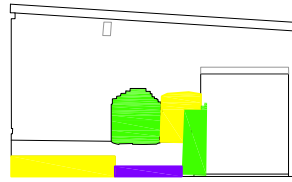

3 MIDWALL ELEV. WEST MODULE I
Scale: 1/16"=1'-0"

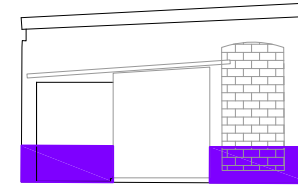

4 EAST ELEV. MODULE I
Scale: 1/16"=1'-0"

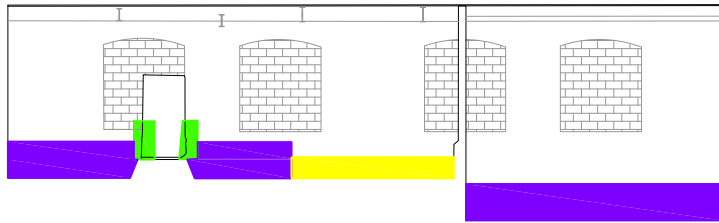



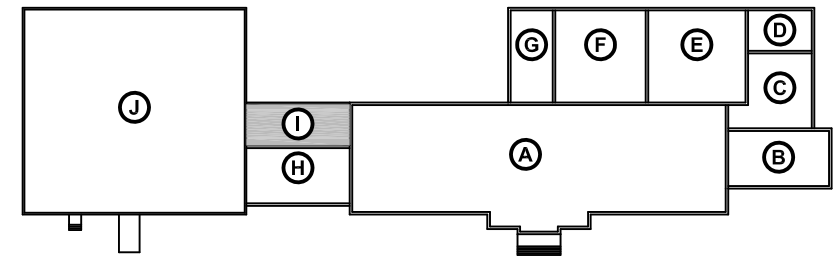



1 SOUTH ELEV. MODULE I
Scale: 1/16"=1'-0"



KEY PLAN
Scale: NONE

SAMPLING AREAS AND SCOPE OF REPAIRS: MODULE I

REPAIR KEY	
	REPOINT
	FULL DEPTH REBUILD
	1 WYTHE REBUILD
	2 WYTHE REBUILD
	2 1/2 WYTHE REBUILD
	CRACK TO REPAIR

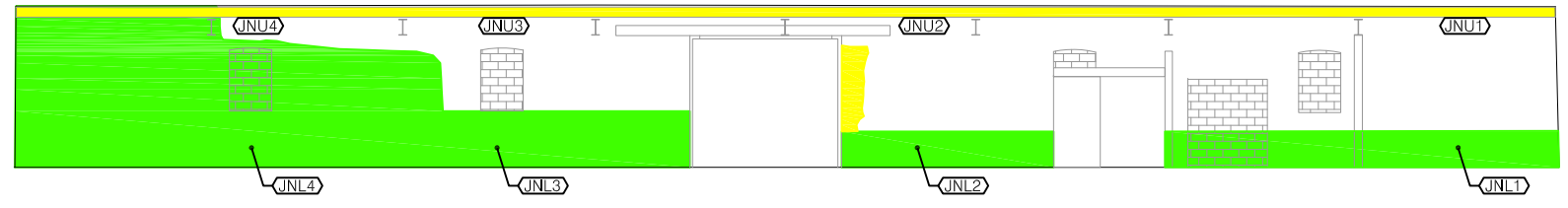

4 NORTH ELEV. MODULE J
Scale: 1/16"=1'-0"

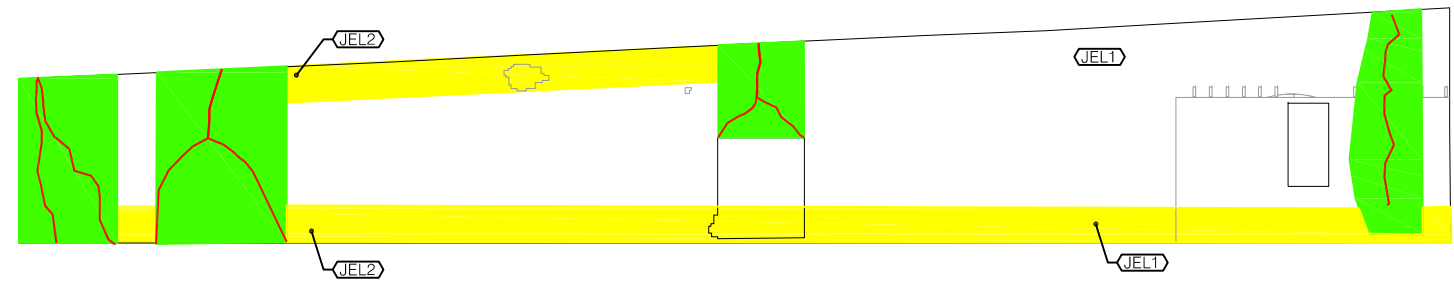

3 EAST ELEV. MODULE J
Scale: 1/16"=1'-0"

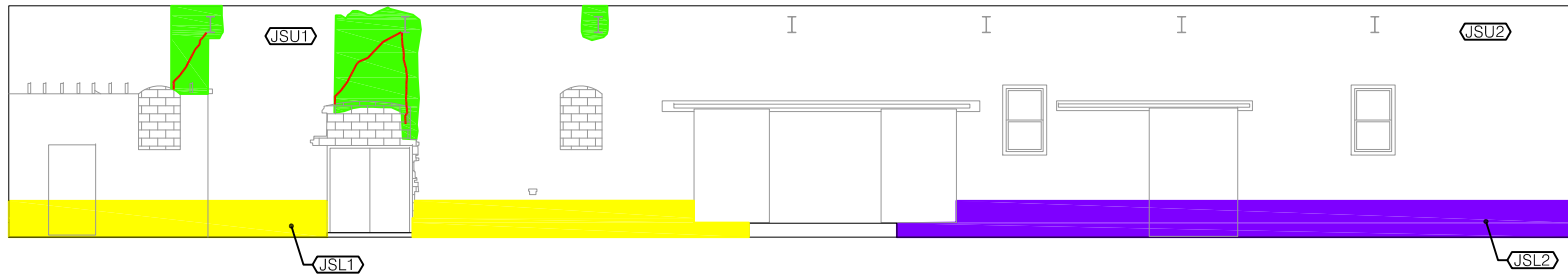

2 SOUTH ELEV. MODULE J
Scale: 1/16"=1'-0"

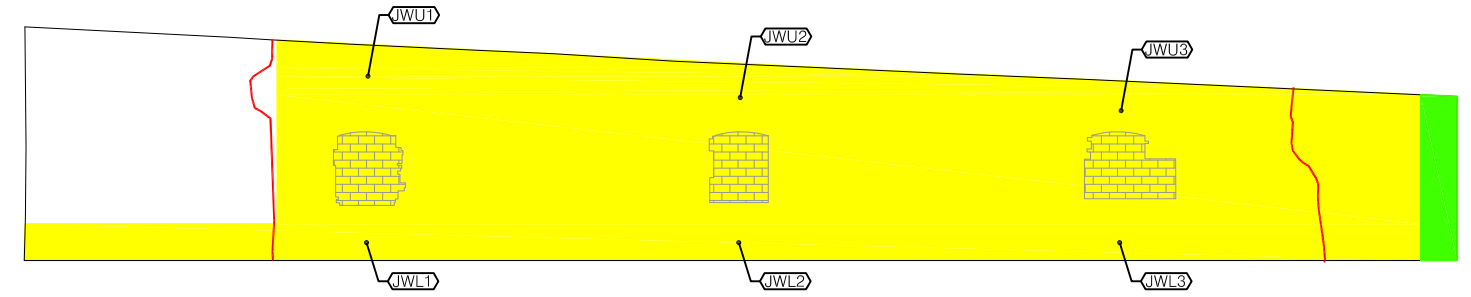

1 WEST ELEV. MODULE J
Scale: 1/16"=1'-0"

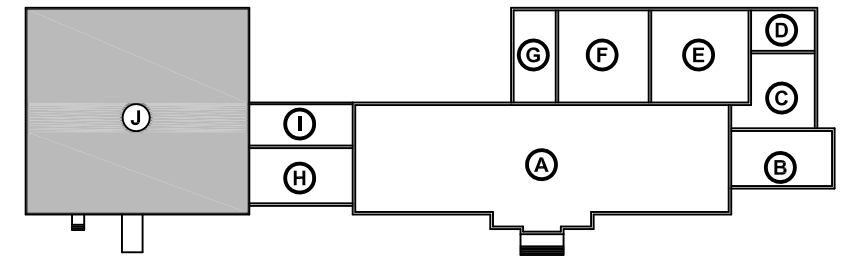







KEY PLAN
Scale: NONE

SAMPLING AREAS AND SCOPE OF REPAIRS: MODULE J

A.1.3

Wall Section Diagrams

REPAIR KEY	
	REPOINT
	FULL DEPTH REPOINT
	1 WYTHE REBUILD
	2 WYTHE REBUILD
	2 1/2 WYTHE REBUILD
	REPLACE CONCRETE/ SILL BAND
	CRACK TO REPAIR

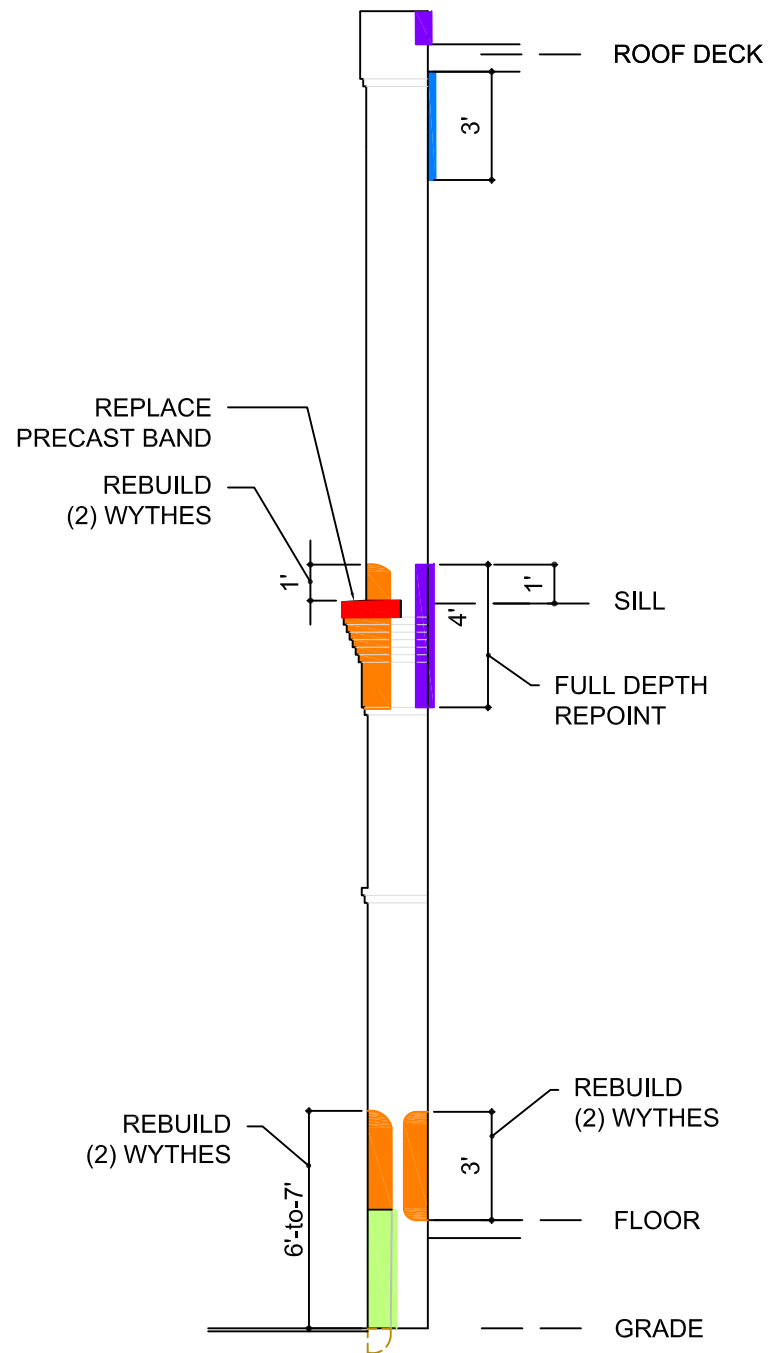

1 SECTION
Scale: NONE

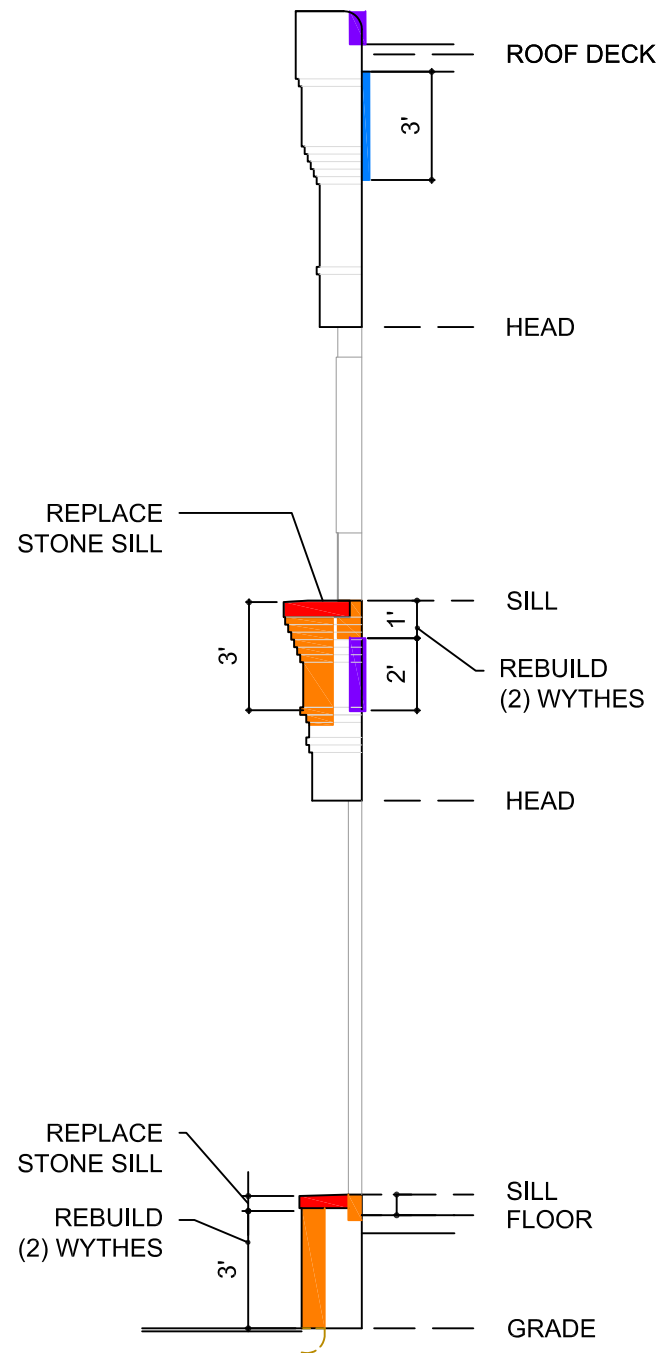

2 SECTION
Scale: NONE

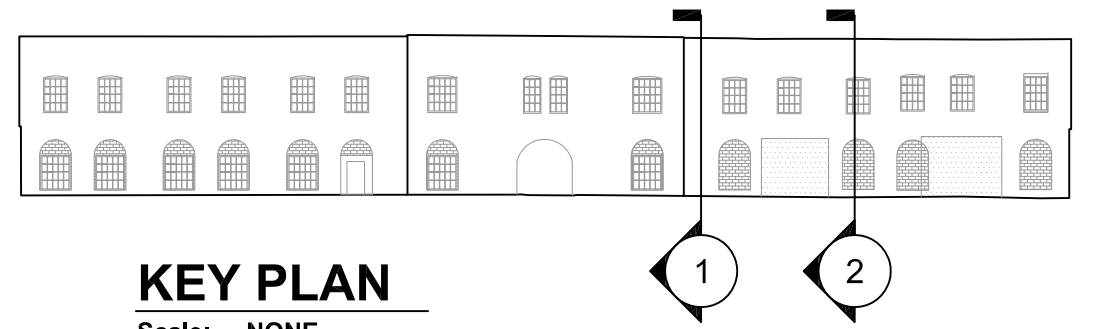

KEY PLAN
Scale: NONE

BUILDING SECTIONS

Section A.2

Sampling / Sounding Log

A.2.1

Exterior

EXTERIOR WALL SAMPLING LOG															
	WALL APREANCE				SOUNDING			BRICK			MORTAR				T.A. = TEST AREA
	10 S.F. at T.A.				3 S.F. at T.A.			at T.A.			at & behind T.A.				
	EXCELLENT	GOOD	FAIR	POOR	SOLID	% OF AREA HOLLOW	DETERIORATED	SOLID	SOFT (WET)	CRUMBLING	SOLID	W/ VOIDS	SOFT (WET)	CRUMBLING	NOTES
MODULE- A	0%	28%	33%	39%	22%	55%	17%	78%	6%	28%	67%	78%	17%	28%	PERCENTAGE OF THE WHOLE
18	0	5	6	7	4		3	14	1	5	12	14	3	5	DATA POINTS
NORTH		0%	33%	67%		53%		67%	0%	67%	67%	100%	0%	33%	
ANU1				1		80%		1		1		1		1	
ANM1				1		80%				1	1	1			
ANL1			1		1	0%		1			1	1			
SOUTH															
UPPER WALL	0%	80%	20%	0%		34%		100%	0%	0%	100%	60%	0%	0%	
ASU1		1			1	0%		1			1	1			
ASU2		1				60%		1			1	1			
ASU3		1				70%		1			1	1			
ASU4		1			1	0%		1			1				
ASU5			1			40%		1			1				
BELOW SILL	0%	20%	60%	20%		56%		80%	0%	20%	60%	100%	0%	20%	
ASM1		1			1	50%		1			1	1			
ASM2			1			70%		1				1		1	
ASM3				1		70%	1			1		1			
ASM4			1			40%		1			1	1			
ASM5			1			50%		1			1	1			
LOWER WALL	0%	0%	20%	80%		78%		60%	20%	40%	40%	60%	60%	60%	
ASL1				1		100%	1		1	1		1	1	1	
ASL2				1		90%		1					1		
ASL3				1		100%	1			1			1	1	roots within wall
ASL4			1			20%		1			1	1		1	
ASL5				1		80%		1			1	1			

EXTERIOR WALL SAMPLING LOG															
	WALL APREANCE				SOUNDING			BRICK			MORTAR			T.A. = TEST AREA	
	10 S.F. at T.A.				3 S.F. at T.A.			at T.A.			at & behind T.A.				
	EXCELLENT	GOOD	FAIR	POOR	SOLID	% OF AREA HOLLOW	DETERIORATED	SOLID	SOFT (WET)	CRUMBLING	SOLID	W/ VOIDS	SOFT (WET)	CRUMBLING	NOTES
MODULE- B	0%	50%	0%	50%	0%	51%	0%	83%	0%	17%	100%	67%	0%	0%	PERCENTAGE OF THE WHOLE
6	0	3	0	3	0		0	5	0	1	6	4	0	0	DATA POINTS
SOUTH	0%	67%	0%	33%		65%		67%	0%	33%	100%	100%	0%	0%	
BSU1		1				40%		1			1	1			
BSM1		1				60%		1			1	1			
BSL1				1		95%				1	1	1			
EAST	0%	33%	0%	67%		37%		100%	0%	0%	100%	33%	0%	0%	
BEU1				1		60%		1			1				
BEM1		1				10%		1			1				
BEL1				1		40%		1			1	1			
MODULE- C	-	-	-	-	-	-	-	-	-	-	-	-	-	-	
0	0	0	0	0	0		0	0	0	0	0	0	0	0	
NOT TESTED DUE TO LIMITED BRICK OVER GARAGE DOORS / NOT ORIGINAL CONSTRUCTION															
MODULE- D	0%	60%	0%	40%	20%	56%	20%	100%	0%	0%	80%	60%	0%	20%	PERCENTAGE OF THE WHOLE
5	0	3	0	2	1		1	5	0	0	4	3	0	1	DATA POINTS
NORTH	0%	50%	0%	50%		45%		100%	0%	0%	50%	100%	0%	50%	
DNU1				1		90%		1				1		1	bricks are loose
DNL1		1				0%		1			1	1			
EAST	0%	67%	0%	33%		65%		100%	0%	0%	100%	33%	0%	0%	
DEU1		1				75%		1			1				
DEM1		1				40%		1			1				
DEL1				1		80%	1	1			1	1			

EXTERIOR WALL SAMPLING LOG															
	WALL APREANCE				SOUNDING			BRICK			MORTAR			T.A. = TEST AREA	
	10 S.F. at T.A.				3 S.F. at T.A.			at T.A.			at & behind T.A.				
	EXCELLENT	GOOD	FAIR	POOR	SOLID	% OF AREA HOLLOW	DETERIORATED	SOLID	SOFT (WET)	CRUMBLING	SOLID	W/ VOIDS	SOFT (WET)	CRUMBLING	NOTES
MODULE- E	0%	67%	0%	33%	0%	57%	33%	67%	0%	33%	67%	33%	33%	33%	PERCENTAGE OF THE WHOLE
3	0	2	0	1	0		1	2	0	1	2	1	1	1	DATA POINTS
NORTH															
ENU1		1				40%		1			1	1			bricks are loose
ENM1		1				30%		1			1				
ENL1				1		100%	1			1			1	1	
MODULE- F	0%	0%	33%	67%	0%	77%	67%	67%	33%	33%	33%	67%	67%	67%	PERCENTAGE OF THE WHOLE
3	0	0	1	2	0		2	2	1	1	1	2	2	2	DATA POINTS
NORTH															
FNU1				1		100%	1		1	1		1	1	1	
FNM1			1			50%		1			1	1			worse below window
FNL1				1		80%	1	1					1	1	
MODULE- G	0%	0%	67%	33%	0%	46%	0%	100%	0%	0%	100%	83%	0%	0%	PERCENTAGE OF THE WHOLE
6	0	0	4	2	0		0	6	0	0	6	5	0	0	DATA POINTS
NORTH															
GNU1				1		80%		1			1				bricks are loose
GNM1			1			30%		1			1	1			
GNL1				1		40%		1			1	1			
WEST															
GWU1			1			10%		1			1	1			
GWM1			1			75%		1			1	1			
GWL1			1			40%		1			1	1			

EXTERIOR WALL SAMPLING LOG															
	WALL APREANCE				SOUNDING			BRICK			MORTAR			T.A. = TEST AREA	
	10 S.F. at T.A.				3 S.F. at T.A.			at T.A.			at & behind T.A.				
	EXCELLENT	GOOD	FAIR	POOR	SOLID	% OF AREA HOLLOW	DETERIORATED	SOLID	SOFT (WET)	CRUMBLING	SOLID	W/ VOIDS	SOFT (WET)	CRUMBLING	NOTES
MODULE- H	0%	0%	100%	0%	0%	40%	0%	100%	0%	0%	100%	67%	33%	0%	PERCENTAGE OF THE WHOLE
3	0	0	3	0	0		0	3	0	0	3	2	1	0	DATA POINTS
SOUTH															
HSU1			1			40%		1			1	1			
HSM1			1			50%		1			1	1			
HSL1			1			30%		1			1		1		
MODULE- I															
2	0%	0%	50%	50%	0%	63%	50%	100%	0%	0%	100%	100%	0%	0%	PERCENTAGE OF THE WHOLE
	0	0	1	1	0		1	2	0	0	2	2	0	0	DATA POINTS
NORTH															
INU1			1			75%		1			1	1			
INL1				1		50%	1	1			1	1			
MODULE- J															
9	0%	22%	22%	56%	0%	62%	56%	44%	11%	56%	67%	78%	0%	22%	PERCENTAGE OF THE WHOLE
	0	2	2	5	0		5	4	1	5	6	7	0	2	DATA POINTS
NORTH															
JNU1			1			70%				1	1	1			
JNL1				1		50%	1			1	1				
SOUTH															
JSU1		1				70%		1			1	1			
JSL1				1		80%	1			1	1				
EAST															
JEU1				1		40%		1			1	1			bricks are loose
JEL1			1			60%	1			1		1			
WEST															
JWU1				1		80%	1		1	1		1		1	
JWM1		1				70%		1			1	1			
JWL1				1		100%	1	1				1		1	

A.2.2

Interior

INTERIOR WALL SAMPLING LOG															
	WALL APREANCE				SOUNDING			BRICK			MORTAR				T.A. = TEST AREA
	10 S.F. at T.A.				3 S.F. at T.A.			at T.A.			at & behind T.A.				
	EXCELLENT	GOOD	FAIR	POOR	SOLID	HOLLOW	DETERIORATED	SOLID	SOFT (WET)	CRUMBLING	SOLID	W/ VOIDS	SOFT (WET)	CRUMBLING	NOTES
ROOM - A	0%	40%	16%	44%	2%	51%	2%	79%	14%	19%	44%	65%	23%	37%	% OF THE WHOLE ROOM
43	0	17	7	19	1		1	34	6	8	19	28	10	16	DATA POINTS
NORTH															
UPPER WALL	0%	75%	25%	0%		26%		100%	0%	0%	50%	50%	0%	0%	% OF THE UPPER PORTION OF NORTH WALL
ANU1		1				30%		1				1			
ANU2			1			40%		1				1			
ANU3		1				10%		1			1				
ANU5		1				25%		1			1				
LOWER WALL	0%	22%	22%	56%		51%		100%	0%	0%	44%	44%	33%	22%	% OF THE LOWER PORTION OF NORTH WALL
ANL1		1				50%		1				1			
ANL2				1		10%		1			1				
ANL3			1			60%		1				1			
ANL4		1				10%		1			1				
ANL5			1			10%		1			1				HEADER COUSE TEST HOLE
ANB1				1		70%		1			1				EXTERIOR WALL - BASE OF WALL
ANB2				1		80%		1					1	1	EXTERIOR WALL - BASE OF WALL
ANB3				1		90%		1				1	1		EXTERIOR WALL - BASE OF WALL
ANB4				1		80%		1				1	1	1	EXTERIOR WALL - BASE OF WALL
WEST	0%	67%	0%	33%		53%		100%	0%	0%	0%	100%	33%	67%	% OF THE WEST WALL
AWU1		1				75%		1				1		1	EXTERIOR WALL
AWM1				1		75%		1				1	1	1	BELOW WINDOW SILL
AWL1		1				10%		1				1			INTERIOR WALL

INTERIOR WALL SAMPLING LOG															
	WALL APREANCE				SOUNDING			BRICK			MORTAR				T.A. = TEST AREA
	10 S.F. at T.A.				3 S.F. at T.A.			at T.A.			at & behind T.A.				
	EXCELLENT	GOOD	FAIR	POOR	SOLID	HOLLOW	DETERIORATED	SOLID	SOFT (WET)	CRUMBLING	SOLID	W/ VOIDS	SOFT (WET)	CRUMBLING	NOTES
SOUTH															
UPPER WALL	0%	100%	0%	0%		24%		100%	0%	0%	83%	50%	0%	0%	% OF THE UPPER PORTION OF SOUTH WALL
ASU1		1				5%		1			1				
ASU2		1				30%		1			1				
ASU3		1				10%		1			1				
ASU6		1				30%		1				1			
ASU7		1				50%		1			1	1			
ASU8		1				20%		1			1	1			
WINDOW SILL	0%	0%	0%	100%		83%		33%	33%	83%	17%	100%	33%	100%	% BELOW 2ND STORY SILL OF SOUTH WALL
ASM1				1		85%		1				1	1	1	BELOW WINDOW SILL / CONCRETE BAND
ASM2				1		80%			1	1		1	1	1	BELOW WINDOW SILL / CONCRETE BAND
ASM3				1		80%			1	1		1		1	BELOW WINDOW SILL / CONCRETE BAND
ASM6				1		80%				1	1	1		1	BELOW WINDOW SILL / CONCRETE BAND
ASM7				1		90%		1		1		1		1	BELOW WINDOW SILL / CONCRETE BAND
ASM8				1		80%				1		1		1	BELOW WINDOW SILL / CONCRETE BAND
MID WALL	0%	67%	0%	33%		52%		83%	17%	17%	83%	33%	17%	17%	% BETWEEN 1ST & 2ND STORY WIN OF SOUTH WALL
ASL1		1				50%		1			1	1			
ASL2		1				60%		1			1				
ASL3				1		100%	1		1	1			1	1	
ASL6		1			1	0%		1			1				
ASL7		1				40%		1			1	1			
ASL8				1		60%		1			1				
BASE OF WALL	0%	0%	20%	80%		49%		40%	40%	40%	0%	80%	60%	100%	
ASL4				1		5%			1	1		1	1	1	EXTERIOR WALL - KNEE HIGH
ASL5				1		20%			1			1		1	EXTERIOR WALL - KNEE HIGH
ASB6			1			50%		1				1		1	EXTERIOR WALL - BASE OF WALL
ASB7				1		80%				1			1	1	EXTERIOR WALL - BASE OF WALL
ASB8				1		90%		1				1	1	1	EXTERIOR WALL - BASE OF WALL
EAST	0%	0%	75%	25%		59%		75%	25%	0%	50%	100%	0%	0%	% OF THE EAST WALL
AEU1			1			80%		1				1			
AEL1				1		75%			1			1			EXTERIOR WALL - BASE OF WALL
AEU2			1			40%		1			1	1			
AEM2			1			40%		1			1	1			

INTERIOR WALL SAMPLING LOG															
	WALL APREANCE				SOUNDING			BRICK			MORTAR				T.A. = TEST AREA
	10 S.F. at T.A.				3 S.F. at T.A.			at T.A.			at & behind T.A.				
	EXCELLENT	GOOD	FAIR	POOR	SOLID	HOLLOW	DETERIORATED	SOLID	SOFT (WET)	CRUMBLING	SOLID	W/ VOIDS	SOFT (WET)	CRUMBLING	NOTES
ROOM - B	0%	71%	21%	7%	21%	36%	0%	93%	0%	7%	71%	36%	14%	14%	PERCENTAGE OF THE WHOLE
14	0	10	3	1	3	5.7	0	13	0	1	10	5	2	2	DATA POINTS
1FT FLOOR															
NORTH	0%	67%	33%	0%		70%		100%	0%	0%	67%	33%	67%	33%	% OF THE NORTH WALL
BNU1		1				80%		1			1	1			
BNL1			1			50%		1			1		1		
BNL2		1				80%		1					1	1	
SOUTH	0%	33%	33%	33%		55%		67%	0%	33%	33%	33%	0%	33%	% OF THE SOUTH WALL
BSU1		1				25%		1				1			
BSL1			1			50%		1			1				
BSL2				1		90%				1				1	
EAST	0%	100%	0%	0%		63%		100%	0%	0%	50%	50%	0%	0%	% OF THE EAST WALL
BEL1		1				65%		1				1			
BEL2		1				60%		1			1				
2ND FLOOR															
NORTH	0%	50%	50%	0%		10%		100%	0%	0%	100%	0%	0%	0%	% OF THE NORTH WALL
BNL3			1			20%		1			1				
BNL4		1			1	0%		1			1				
WEST	0%	100%	0%	0%		0%		100%	0%	0%	100%	100%	0%	0%	% OF THE WEST WALL
BWL1		1			1	0%		1			1	1			
SOUTH	0%	100%	0%	0%		25%		100%	0%	0%	100%	50%	0%	0%	% OF THE SOUTH WALL
BSL3		1				20%		1			1				
BSL4		1				30%		1			1	1			
EAST	0%	100%	0%	0%		0%		100%	0%	0%	100%	0%	0%	0%	% OF THE EAST WALL
BEL3		1			1	0%		1			1				
ROOM - C	0%	0%	100%	0%	0%	55%	0%	100%	0%	0%	0%	0%	100%	0%	PERCENTAGE OF THE WHOLE
2	0	0	2	0	0		0	2	0	0	0	0	2	0	DATA POINTS
CWL1			1			50%		1					1		
CSL1			1			60%		1					1		
ROOM - D	-	-	-	-	-	-	-	-	-	-	-	-	-	-	
0	0	0	0	0	0		0	0	0	0	0	0	0	0	
ROOM UNSAFE FOR TESTING															

INTERIOR WALL SAMPLING LOG															
	WALL APREANCE				SOUNDING			BRICK			MORTAR				T.A. = TEST AREA
	10 S.F. at T.A.				3 S.F. at T.A.			at T.A.			at & behind T.A.				
	EXCELLENT	GOOD	FAIR	POOR	SOLID	HOLLOW	DETERIORATED	SOLID	SOFT (WET)	CRUMBLING	SOLID	W/ VOIDS	SOFT (WET)	CRUMBLING	NOTES
ROOM - E	0%	56%	11%	33%	0%	26%	11%	78%	11%	22%	44%	78%	11%	22%	PERCENTAGE OF THE WHOLE
9	0	5	1	3	0		1	7	1	2	4	7	1	2	DATA POINTS
ESU1		1				5%		1			1	1			
ESL1		1				10%		1				1			
ESL2		1				5%		1				1			HEADER COUSE TEST HOLE
EEU1		1				20%		1			1	1			
EEM1		1				5%		1			1	1			
EEL1			1			5%		1				1			
ENU1				1		20%		1			1				
ENM1				1		80%				1		1		1	
ENL1				1		80%	1		1	1			1	1	EXTERIOR WALL - BASE OF WALL
ROOM - F	0%	33%	67%	0%	0%	53%	0%	67%	0%	33%	67%	33%	33%	33%	PERCENTAGE OF THE WHOLE
3	0	1	2	0	0		0	2	0	1	2	1	1	1	DATA POINTS
FEM1		1				30%		1			1	1			
FEL1			1			50%		1			1				
FNL1			1			80%				1			1	1	
ROOM - G	-	-	-	-	-	-	-	-	-	-	-	-	-	-	
0	0	0	0	0	0		0	0	0	0	0	0	0	0	
ROOM UNSAFE FOR TESTING															
ROOM - H	0%	80%	20%	0%	10%	31%	0%	100%	0%	0%	80%	20%	10%	0%	PERCENTAGE OF THE WHOLE
10	0	8	2	0	1		0	10	0	0	8	2	1	0	DATA POINTS
HNU1			1			40%		1			1	1			
HNM1		1				20%		1			1				
HNL1		1				60%		1			1				
HWU1		1				10%		1					1		
HWM1		1				60%		1			1				
HWL1		1				20%		1			1				EXTERIOR WALL - BASE OF WALL
HSU1		1				30%		1				1			
HSM1			1			50%		1			1				
HSL1		1			1	0%		1			1				
HEL1		1				20%		1			1				

INTERIOR WALL SAMPLING LOG															
	WALL APREANCE				SOUNDING			BRICK			MORTAR				T.A. = TEST AREA
	10 S.F. at T.A.				3 S.F. at T.A.			at T.A.			at & behind T.A.				
	EXCELLENT	GOOD	FAIR	POOR	SOLID	HOLLOW	DETERIORATED	SOLID	SOFT (WET)	CRUMBLING	SOLID	W/ VOIDS	SOFT (WET)	CRUMBLING	NOTES
ROOM - I	0%	0%	100%	0%	0%	57%	0%	100%	0%	0%	100%	0%	33%	0%	PERCENTAGE OF THE WHOLE
3	0	0	3	0	0		0	3	0	0	3	0	1	0	DATA POINTS
IWL1			1			90%		1			1		1		
ISM1			1			20%		1			1				
ISL1			1			60%		1			1				
															NORTH WALL UNSAFE FOR TESTING
ROOM - J	0%	22%	22%	57%	0%	75%	30%	48%	26%	52%	39%	70%	35%	39%	PERCENTAGE OF THE WHOLE
23	0	5	5	13	0	16.2	7	11	6	12	9	16	8	9	DATA POINTS
NORTH	0%	22%	11%	67%		83%		33%	33%	67%	22%	100%	67%	67%	
JNU1		1				90%		1				1			GAP BETWEEN WYTHS
JNL1				1		100%	1		1	1		1	1	1	EXTERIOR WALL - BASE OF WALL
JNU2				1		70%		1			1	1			
JNL2				1		100%	1			1		1	1	1	
JNU3		1				40%		1			1	1			
JNM3				1		75%				1		1	1	1	
JNL3				1		100%	1		1	1		1	1	1	
JNU4			1			75%	1			1		1	1	1	
JNL4				1		100%	1		1	1		1	1	1	
WEST	0%	0%	17%	83%		75%		33%	17%	67%	50%	67%	0%	17%	
JWU1				1		50%				1					
JWL1				1		80%		1			1				
JWU2				1		90%				1		1		1	
JWL2			1			90%		1			1	1			
JWU3				1		50%	1			1	1	1			
JWL3				1		90%	1		1	1		1			
SOUTH	0%	25%	50%	25%		48%		60%	20%	25%	50%	50%	25%	25%	
JSU1			1			25%		1				1			
JSL1				1		75%			1	1			1	1	EXTERIOR WALL - BASE OF WALL
JSU2		1				0%		1			1				
JSL2			1			90%		1			1	1			
EAST	0%	50%	25%	25%		58%		60%	20%	0%	50%	25%	25%	25%	
JEU1		1				70%		1			1				
JEL1			1			20%		1			1				INTERIOR WALL - BASE OF WALL
JEU2		1				90%		1				1			INNER WYTH BLACKENED
JEL2				1		50%			1	1			1	1	EXTERIOR WALL - BASE OF WALL

Section A.3

Analysis and Testing Report

A.3.1

Schmitt Technical Services, Inc.



January 9, 2013

Mr. Peter Anderson
 Facility Engineering, Inc.
 101 Dempsey Road
 Madison, WI 53714

RE: Laboratory Analysis on Brick and Masonry Mortar, Garver Feed Mill Evaluation Project, Madison, WI

Dear Mr. Anderson:

Schmitt Technical Services, Inc. (STS) has completed laboratory testing to evaluate condition, composition and quality of samples taken from clay brick and masonry mortar as part of an evaluation into reuse of existing structures at the Garver Feed Mill, Madison, WI. The Garver Mill building was reported to be constructed in 1905/1906. The samples were received at STS on December 12, 2012. Sample identifications are provided in Table 1.

Table 1 –Sample Identifications, Descriptions and Tests Performed		
Facility Eng. ID	Sample Description	Test(s) Performed
(I)ASL5	Two Masonry Mortar Fragments	ASTM C 1324
(I)ASLI M	Clay Brick	ASTM C 67 Suction, Absorption & Sat. Coeff.
(E)ASM4 M	Clay Brick	ASTM C 67 Suction, Absorption & Sat. Coeff.
(E)ASM5 C	Clay Brick	ASTM C 67 Compressive Strength
(I)ASM6 C	Clay Brick	ASTM C 67 Compressive Strength
(E)BEH1 C	Clay Brick	ASTM C 67 Compressive Strength
(E)DEL1 M	Clay Brick	ASTM C 67 Suction, Absorption & Sat. Coeff.
(I)EEL1 M	Clay Brick	ASTM C 67 Suction, Absorption & Sat. Coeff.
(I)EEU1 C	Clay Brick	ASTM C 67 Compressive Strength
(E)FNL1 M	Clay Brick	ASTM C 67 Suction, Absorption & Sat. Coeff.
(E)GWL1 C	Clay Brick	ASTM C 67 Compressive Strength

The following analyses were performed:

- (a) Petrographic and chemical analysis on the masonry mortar to determine the cementitious to sand ratio and masonry type by ASTM C1324 and
- (b) Combined physical testing (absorption, compressive strength and saturation coefficient according to ASTM C 67) on clay brick samples.

FINDINGS AND CONCLUSIONS

Subject to the qualifications in the attached Appendix A, the following findings and conclusions are made:

1. The mortarsample was analyzed for calcium oxide, insoluble residue and loss on ignition (LOI) at 105°C, 550°C and 950°C. From this data, composition content of the hardened sample was calculated. Results are summarized in Table 2 below.

Table 2. Chemical Analysis Results for Garver Feed Mill Masonry Mortar (ASTM C 1324)			
STS Project No.:	12098	Report Date:	Jan. 9, 2013
Client:	Facility Engineering	Examined by:	James Schmitt
Project:	Garver Feed Mill Evaluation	Method:	ASTM C 1324
Location:	Madison, WI	Analyst:	Elizabeth Otteson
Submitter:	Peter Bloechl-Anderson		
Lab Determined Composition (as %)		Mortar	
Calcium oxide		42.39	
Insoluble Residue (Sand)		35.73	
L.O.I. @ 105° C		0.66	
L.O.I. @ 550° C		3.80	
L.O.I. @ 950° C		9.22	
Calculated Composition⁽¹⁾		Mortar	
Portland Cement, %		52.34	
Hydrated Lime, %		8.40	
Sand, %		35.73	
PC: Hydrated Lime: Sand Volumetric Proportions		1.0:1.2:2.6	
Notes: (1) Ratios are calculated based on loose volumetric proportions, using loose bulk density of 94 pcf for Portland Cement (PC), 40 pcf for hydrated lime and 80 pcf for sand.			

2. Thus, the chemical analysis determined the Portland cement-hydrated lime-to-aggregate ratio of the masonry mortar to be:

Mortar Sample	
(Portland Cement: Hydrated Lime: Aggregate Volumetric Proportions)	
Mortar	1.0: 1.2: 2.6

3. Petrographic examination reveals the masonry mortar to be composed of a mixture of calcareous and siliceous (primarily quartz and dolomite), natural sand as aggregate (Figure 3) encased in a highly carbonated Portland cement paste matrix (Figure 4). Measured maximum aggregate size is 3 mm (0.12 in. or passing the No. 4 US standard mesh sieve screen). Coarser sizes are scarce. Most of the aggregate is finer than 0.5 mm (or passing a 35 mesh screen; Figure 3). Thus, the aggregate is close to, but slightly finer

than the gradation required in ASTM C 144 (Standard Specification for Aggregate for Masonry Mortar). The sand appears durable and is performing as intended. This sand is typical of glacial sands in the region often used as concrete and masonry aggregate.

4. A small amount of hydrated lime is present in the mortar matrix as cement sized balls (Figure 3) and is estimated to be less than 1%, by volume of paste (see also Table 2). No supplementary cementitious materials are observed. The cement is well-hydrated as there are very few residual cement particles or even relicts of cement particles present. Properties of the mortar suggest a water-cement ratio estimated to be in the range of 0.45-to-0.55. However, the paste now is soft, very porous and contains numerous microcracks (Figure 5), likely a result of freeze-thaw damage. Many of these microcracks are lined to filled with secondary calcium carbonate, suggesting moisture has migrated through the mortar, leached calcium from the cement paste and redeposited the calcium as calcium carbonate.
5. The mortar is non-air entrained with many of the voids being small-to-large and irregularly shaped. Air content is estimated to be 8-to-12%. The air voids are lined with secondary deposits of calcium carbonate and ettringite, also suggesting migration of moisture into the mortar, and thus, being susceptible to freeze-thaw damage when saturated.
6. Petrographic observations and the mortar proportions provided in Table 2 yield a composition that would be similar to a Type O Cement-Lime Mortar, as classified in ASTM C 270, "Standard Specification for Mortar for Masonry Units", even though ASTM C 270 was not in existence at the time this mortar was placed. An ASTM C 270 Type O Cement-Lime Mortar is required to have a 28 day, minimum, average compressive strength of 350 psi. Table X1.1 of the Appendix of ASTM C 270 indicates a Type O mortar is suitable for interior, non-load bearing partitions and exterior above grade, non-load bearing walls that are not likely to be frozen when saturated.
7. Brick compressive strength test results are provided in Table 3 below:

Table 3 – ASTM C 67 Brick Compressive Strength Test Results						
Facility Eng. ID	(E)ASM5 C	(I)ASM6 C	(E)BEH1 C	(I)EEU1 C	(E)GWL1 C	Average
Length (in)	3.95	3.89	3.89	3.95	3.86	----
Width (in)	3.74	3.72	3.65	3.77	3.74	----
Area (sq. in)	14.8	14.5	14.2	14.9	14.4	----
Load (lbs)	35,670	28,020	30,640	34,930	37,020	----
Compressive Strength (psi)	2,415	1,935	2,160	2,345	2,565	2,285
Notes: Bricks had numerous cracks, chips and imperfections.						

8. ASTM C 62, “Standard Specification for Building Brick (Solid Masonry Units Made from Clay or Shale)” requires that for exposure to severe weathering conditions (Grade SW), brick must have a minimum compressive strength of 2,500 psi for an individual brick and 3,000 psi for an average of 5 bricks. Data in Table 3 indicate the in-place project brick do not meet the average strength requirement and only one of the five bricks tested meets the individual strength requirement. The data does suggest some variability in strength, possibly due to certain locations being in better condition and higher strength than others. Thus, the data has to be analyzed against the field survey observations.
9. Brick absorption test results are provided in Table 4 below:

Table 4 – ASTM C 67 Brick Absorption Test Results						
Facility Eng. ID	(I)ASLI M	(E)ASM4 M	(E)DEL1 M	(I)EEL1 M	(E)FNL1 M	Average
Initial Rate of Absorption (g/min/30in²)	27.8	33.0	21.9	11.0	9.9	20.7
24 Hr. Absorption (%)	21.2	19.5	16.6	10.7	13.5	16.3
5 Hr. Boil Absorption (%)	26.8	22.6	19.0	15.2	15.7	19.9
Saturation Coefficient	0.79	0.86	0.87	0.70	0.86	0.82
Notes: Initial rate of absorption was determined on air dry weight.						

10. For new building construction, the Wisconsin Department of Administration, Division of State Facilities (DSF) requires the initial rate of absorption to be a minimum of 3 g/min/30in² for an individual brick and a minimum of 5 g/min/30in² for an average of five bricks. The project bricks meet this requirement. DSF also requires the initial rate of absorption to be a maximum of 25 g/min/30in² for an individual brick and a maximum of 20 g/min/30in² for an average of five bricks. The individual maximum requirement is exceeded in two of the bricks and the average of 5 is at the upper limit requirement. Again, the data has to be analyzed against the field survey observations to best sort out this variability.
11. ASTM C 62 also has requirements pertaining to severe weathering conditions for absorption and saturation coefficient. For Grade SW brick, the 24 hour absorption should not exceed 8% for 5 individual bricks. All of the bricks exceed the 8% requirement.
12. ASTM C 62 states that if the 24 hour absorption requirement is exceeded, the brick should be evaluated by both the 5 hour boil absorption and the saturation coefficient. Five hour boil absorption (for Grade SW) should not exceed 17% for an average of 5 bricks and 20% for an individual brick. Two of the bricks exceed the individual maximum requirement for 5-hour boil absorption. The average of five bricks for the 5-hour boil exceeds the maximum limit.

13. ASTM C 62 states the saturation coefficient shall not exceed 0.78 for an average of 5 bricks and 0.80 for an individual brick. Three of the bricks exceed the maximum saturation coefficient for individual brick. The average of five bricks exceeds the 0.78 requirement.
14. Based on the testing and analyses performed, condition and quality of the masonry is variable depending on location. In some areas, the present quality is poor. In other areas, the condition and quality is marginal. Additional brick testing should be done to further delineate acceptable from nonusable areas. It should be noted that none of the existing project masonry is even close to the quality and long-term, lower maintenance of new masonry.

Additional details of the petrographic examination are provided later in this report.

LABORATORY PROCEDURES

Chemical Analysis

Chemical analysis of the mortar was performed per ASTM C 1324, "Standard Test Method for Examination and Analysis of Hardened Masonry Mortar." Determination of calcium oxide level was performed using ASTM C114, "Standard Test Method for Chemical Analysis of Hydraulic Cement: Section 9: Ammonium Hydroxide and Section 15: Calcium Oxide".

Petrographic Analysis

The mortar was examined using techniques and procedures outlined in ASTM C 1324, "Standard Test Method for Examination and Analysis of Hardened Masonry Mortar" And ASTM C 856, "Standard Practice for Petrographic Examination of Hardened Concrete" and the Federal Highway Administration's Publication No. FHWA-HRT-04-150, "Petrographic Methods of Examining Hardened Concrete: A Petrographic Manual."

The mortar examination included sawing the sample longitudinally; followed by lapping one half of the sawed slice with successively finer lapping grits to produce a finely ground (and nearly polished) surface of the entire mortar thickness. The lapped surface and freshly broken surfaces of the specimen were examined visually (with the unaided eye) and under a stereomicroscope at magnifications of 7 to 40X.

In addition, a thin section was made from the mortar, as were temporary, crushed fragment (i.e., "powder or immersion") mounts. The thin section and immersion mounts were examined under plane and cross-polarized light at magnifications of 50 to 400X using a polarizing light microscope.

Estimates of water-to-cement ratio were done using techniques outlined in FHWA-HRT-04-150 and methods developed by Dr. Donald Campbell (unpublished).

Physical Testing of Clay Brick

Absorption, compressive strength, initial rate of absorption (suction) and saturation coefficient of the clay brick were determined using methods outlined in ASTM C 67, "Standard Test Methods for Sampling and Testing Brick and Structural Clay Tile."

PETROGRAPHIC EXAMINATION

Masonry Mortar

General Description

The sample consists of two (2) mortar fragments identified as "(I) ASL5" (Figures 1 and 2). One fragment has dimensions of 2-1/4 in. by 3 in. by 1/2 in. The other fragment has dimensions of 3 in. by 3-3/4 in. by 1/2 in. The top and bottom surfaces of the fragments are flat imprints of adjacent brick; thus, the specimens represent the full thickness of a mortar joint. Side of the fragments are mostly broken surfaces, although a few surfaces are weathered, tooled mortar surfaces and one surface is the overflow spillage of the back side of a brick.

Mortar Aggregates

The aggregate is uniformly dispersed throughout the mortar. Measured maximum aggregate size is 3mm (0.12 in or passing the No. 4 US standard mesh sieve screen). However, coarser sizes are rare. Most of the aggregate is finer than 0.5 mm (or passing a 35 mesh screen; Figure 3). The aggregate is close to but slightly finer than the gradation required in ASTM C 144 (Standard Specification for Aggregate for Masonry Mortar).

Aggregate is natural sand composed of a wide variety of rock and mineral types including quartz, feldspar, chert, chalcedony, dolomite and granite (Figure 4). Quartz is the most prominent mineral component of the aggregate. Aggregate is translucent, brown, tan and beige. Aggregate is hard; dense; sub-angular to well-rounded; mainly equant in shape and has a smooth surface texture.

The aggregate does not exhibit deterioration or evidence of poor service performance. Rather, the aggregate observed appears to be performing as intended.

Mortar Cement Paste

Cement paste is white, fairly soft, highly porous and weakly bonded to aggregate particles. Paste exhibits a porcelaneous luster, amorphous to saccharoidal texture and an irregular fracture. Cement paste is extensively carbonated (Figure 4).

The cement is well-hydrated as there are very few residual cement particles or even relicts of cement particles present. Calcium hydroxide content, a normal hydration product, cannot be discerned due to extensive paste carbonation. Hydrated lime is present in the mortar (Figure 3).

Properties of the paste previously described are evaluated to provide an estimate of the water-to-cement ratio. Based on paste properties observed, water-cement ratio is estimated to be moderate, that is, estimated to be in the range of 0.45-to-0.55.

There are numerous microcracks in the paste (Figure 5), likely a result of freeze-thaw damage. Many of these microcracks are lined to filled with secondary calcium carbonate, suggesting moisture has migrated through the mortar, leached calcium from the cement paste and redeposited the calcium as calcium carbonate.

Mortar Air Voids

There are numerous small-to-large, irregularly shaped voids typical of entrapped air (Figure 4), but no smaller spherical voids typical of entrained air. Therefore, the mortar is non-air entrained.

Air content is estimated to be 8-to-12%, by volume. The air voids are lined secondary deposits of calcium carbonate and ettringite, suggesting migration of moisture into the mortar.

We sincerely appreciate your choice of Schmitt Technical Services, Inc. to assist you in this evaluation. If you have any questions or need additional consultation, please contact us.

Sincerely,

Schmitt Technical Services, Inc.



Elizabeth M. Otteson
Chemist/Manager Chemistry Services

Facility Engineering
Analysis of Masonry Mortar and Clay Brick
Garver Feed Mill, Madison, WI
STS Project No. 12098
January 9, 2013

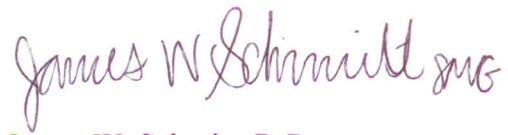
A handwritten signature in dark ink, reading "James W. Schmitt P.G.", written in a cursive style.

James W. Schmitt, P.G.
Principal/President

JWS/jws

Attachments

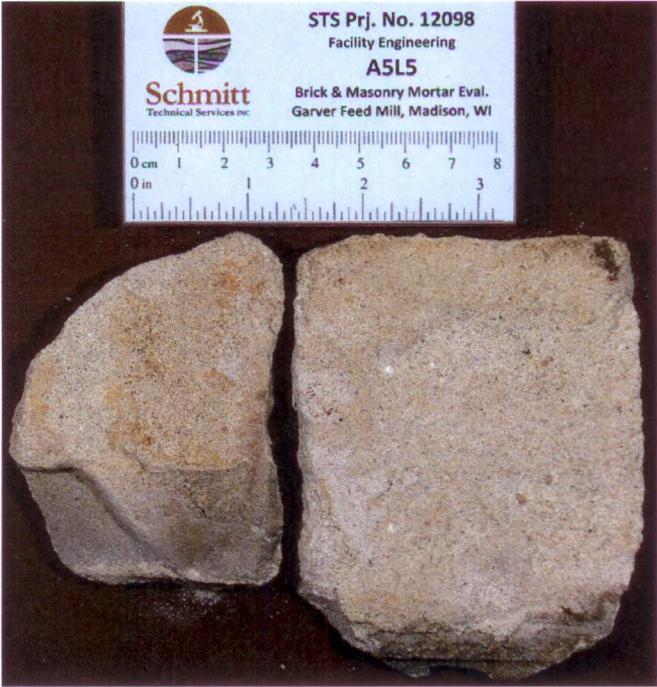

Figure 1. Mortar Sample “(I) ASL5” as received in the laboratory for testing. Top scale is in centimeters. Bottom scale is in inches.



Figure 2. Another view of Mortar Sample “(I) ASL5” as received in the laboratory for testing. Top scale is in centimeters. Bottom scale is in inches.

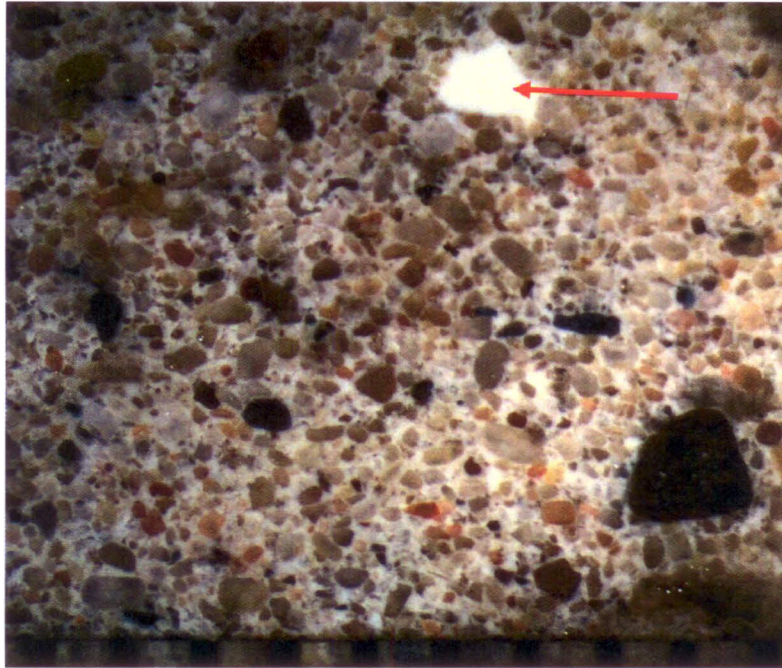

Figure 3. Photomicrograph along the lapped surface of the mortar sample. The somewhat fine natural sand aggregate is encased in a cement paste matrix that is off-white. Red arrow points to a hydrated lime ball. Scale is in millimeters.

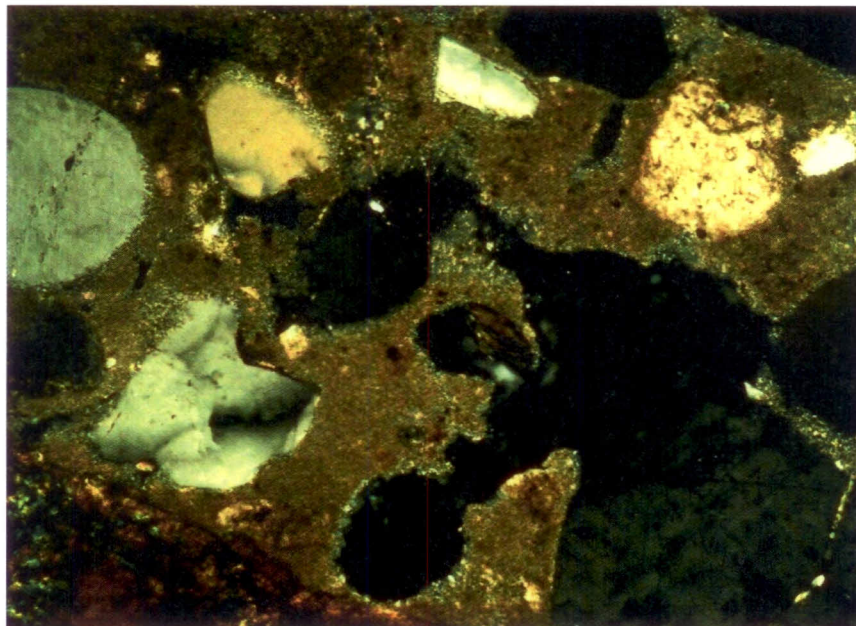

Figure 4. Thin section photomicrograph of the masonry mortar sample. Gray (quartz), yellow (quartz), gold (dolomite) and brown (igneous rock) aggregate particles are set in a fine grained dull gold to dull bronze matrix of carbonated (which is why it is gold) cement paste. Black areas are entrapped air voids. 100x magnification. Crossed polarized light.

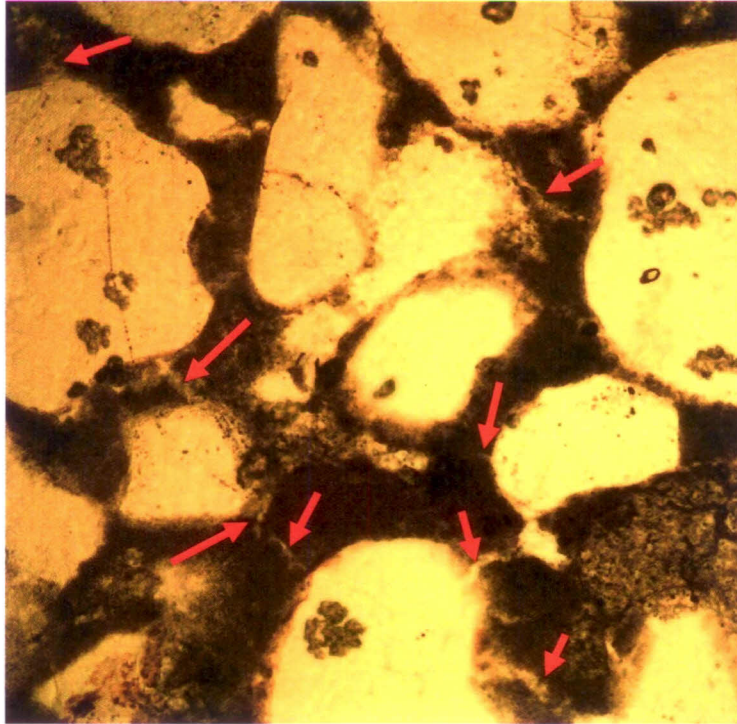

Figure 5. Thin section photomicrograph of the masonry mortar sample. Red arrows point to microcracks prevalent throughout the cement paste matrix. 100x magnification. Plane polarized light.

APPENDIX DOCUMENT QUALIFICATIONS

Standard of Care

This report has been prepared for the exclusive use of the Client for specification application to their project. This report is not intended for use by others. Schmitt Technical Services, Inc. (STS) has provided professional services consistent with generally accepted evaluative and geologic practices. No other warranties are expressed or implied. The opinions and recommendations submitted in this report are based on interpretation of field observations, samples taken from specific locations and/or field and/or laboratory test results.

Samples

The samples taken during the field observations depict conditions only at specific locations and times indicated in the report. Conditions at other locations may differ from conditions where sampling was conducted. The passage of time may also result in changes in conditions interpreted to exist at the locations where sampling was conducted.

Completion of Characterization of Site Conditions

The scope of services described in this report is based on a limited number of samples. The nature and variations in other locations may exist and may not become evident until repairs are performed. If variations or other latent conditions become evident, additional evaluation and testing may be warranted.

Conceptual Level of Project Scope

The field activities, testing procedures and evaluative approaches used in this study are consistent with those normally used in testing of construction materials and products. The number of samples and tests and scope of testing were done within Client's budget, but represents less data than that generally needed to evaluate the extent of less than expected performance.

Test Repair and Repair Observations and Testing

Since findings, discussion and observations are based on limited numbers of observations and tests, the Client should be particularly sensitive to the potential need for adjustment in extent of repair, repair procedures and repair materials in the field. It is in the best interest of the client to retain STS to observe and test repair materials and repairs to observe general compliance with repair design concepts, specifications and contractor/manufacture recommendations and to assist in development of changes should field conditions differ from those anticipated before the start of repair construction.

Limitations-Repair Construction Considerations

The recommendations made in the report are not intended to dictate type of repair materials to be used, construction methods or construction sequences. Prospective contractors and material suppliers must evaluate potential repair problems on the basis of their knowledge and experience in the local area and on the basis of similar project in other localities, taking into account their own proposed repair construction methods and procedures.

Testing Conducted by Others

When subcontracted outside field and/or laboratory services and analyses are used, STS will rely upon the data provided by the outside field service or laboratory, and will not conduct an independent evaluation of the reliability of their data.

A.3.2

CGC, Inc.

CGC, INC.

TEST REPORT
COMPRESSIVE STRENGTH
OF MASONRY PRISM
ASTM C 1314

Test No. 9055
Job No. C13024
Date January 22, 2013
Sheet 1 of 1

CGC, Inc. . 2921 Perry Street . Madison, WI 53713 . Tel. 608/288-4100 . FAX 608/288-7887

PROJECT Masonry Brick Prism Tests

TO Structural Integrity, Inc.
7702 Terrace Ave., Suite 1
Middleton, WI 53562

ATTENTION Mr. Kurt Straus

COPIES TO 1-Client 1-File

SAMPLING AND TEST DATA

SAMPLED BY Not available DATE SAMPLED 01-11-13 DATE RECEIVED 01-11-13

MORTAR TYPE Not Available TYPE OF USE _____

SUPPLIER Not Available CONTRACTOR Not Available

Prism No.	LOCATION	HEIGHT IN.	LENGTH IN.	WIDTH IN.	CORR. FACT.	AREA IN ²	MAX. LOAD LBS	AGE DAYS	PSI
1		16.24	8.22	3.71	1.0	30.50	26,360	NA	860
2		16.34	8.02	3.62	1.0	29.03	21,280	NA	730

AVERAGE COMPRESSIVE STRENGTH 790 SPECIFIED COMPRESSIVE STRENGTH _____

TESTING OBSERVATIONS Prism 1 - mortar bond between lowest brick and seconded lowest brick was broke at time of delivery. Mortar joints in both prisms varied in thickness and had gaps. Bricks were not laid vertical.

COMMENTS NA = Not Available

SIGNATURE K. D Lewis DATE 1/22/13

A.3.3

Vogel Bros. Building Co.

Garver Masonry Repair Statement of Probable Costs Summary

Line No.	Module	Module Area	Estimated Stabilization Cost	Estimated Demolition Cost
1	Module A	15,838 SF	\$1,240,094	\$436,000
2	Module B	2,248 SF	\$159,922	\$62,000
3	Module C	1,997 SF	\$134,928	\$55,000
4	Module D	1,080 SF	\$143,497	\$30,000
5	Module E	3,392 SF	\$549,194	\$93,000
6	Module F	3,145 SF	\$419,966	\$87,000
7	Module G	1,595 SF	\$316,704	\$44,000
8	Module H	2,202 SF	\$285,065	\$61,000
9	Module I	1,656 SF	\$134,272	\$46,000
10	Module J	16,599 SF	\$1,175,541	\$457,000
11	Total Estimated Cost		\$4,559,183	\$1,371,000
12	Total Project Area	49,751 SF		

Module A Cost Estimate

Module A		Module Size		15,838 SF	
Line No.	Description of Work	Quantity	Unit Measure	Cost per Unit	Estimated Cost
1	Existing Conditions				
2	Remove loose & hanging debris from roof and floor	15,838	SF	\$0.60	\$9,575
3	Demolition of roof structure	15,838	SF	\$1.51	\$23,939
4	Masonry				
5	Tooth walls together	32	LF	\$56.17	\$1,797
6	Masonry Restoration				
7	Repoint	2,132	SF	\$21.67	\$46,196
8	Full Depth Repoint	879	SF	\$24.36	\$21,406
9	1 Wythe Rebuild	3,877	SF	\$30.46	\$118,096
10	2 Wythe Rebuild	3,210	SF	\$33.88	\$108,760
11	2-1/2 Wythe Rebuild	1,411	SF	\$46.09	\$65,009
12	Replace concrete/sill band	386	LF	\$91.57	\$35,349
13	Crack to Catch	213	LF	\$42.73	\$9,119
14	Structural Steel				
15	Removing and replacing the damaged horizontal angle portion and epoxy-bolting the existing channel back the masonry wall.	1	EA	\$1,311	\$1,311
16	Steel angel at roof perimeter	610	LF	\$12.25	\$7,471
17	Rough Carpentry				
18	Roof Framing	15,838	SF	\$8.82	\$139,754
19	Thermal and Moisture Protection				
20	Membrane roofing system	15,838	SF	\$9.77	\$154,692
21	Finishes				
22	Painting Steel Beam	1	LS	\$19,433	\$19,433
23	Plumbing				

Module A Cost Estimate

Module A		Module Size		15,838 SF	
Line No.	Description of Work	Quantity	Unit Measure	Cost per Unit	Estimated Cost
24	Roof drain piping system	15,838	SF	\$2.44	\$38,673
25	Electrical				
26	Power for lights and other equipment	15,838	SF	\$6.10	\$96,683
27	Site Utilities				
28	Electrical and Water Service	1	LS	\$19,433	\$19,433
29	Subtotal Module A Estimated Cost				\$916,694
30	Estimating Contingency		5%		\$45,800
31	Unforeseen Conditions Contingency		5%		\$45,800
32	2 Year Escallation Contingency		5%		\$45,800
33	City of Madison Contingency		8%		\$73,300
34					
35	A/E Fee Estimate		10%		\$112,700
36	Total Module A Estimated Cost				\$1,240,094

Module B Cost Estimate

Module B		Module Size		2,248 SF	
Line No.	Description of Work	Quantity	Unit Measure	Cost per Unit	Estimated Cost
1	Concrete Repairs				
2	Patch spalled concrete on underside of Roof	50	SF	\$12.20	\$610
3	Masonry Restoration				
4	Repoint	0	SF		\$0
5	Full Depth Repoint	266	SF	\$24.36	\$6,481
6	1 Wythe Rebuild	562	SF	\$30.46	\$17,120
7	2 Wythe Rebuild	787	SF	\$33.88	\$26,652
8	2-1/2 Wythe Rebuild	229	SF	\$46.09	\$10,535
9	Replace concrete/sill band	111	LF	\$91.57	\$10,139
10	Crack to Catch	0	LF		\$0
11	Structural Steel				
12	Steel framing	0	LF		\$0
13	Rough Carpentry				
14	Roof Framing	0	SF		\$0
15	Thermal and Moisture Protection				
16	Membrane roofing system	2,248	SF	\$9.77	\$21,956
17	Finishes				
18	Painting Steel Beam	1	LS	\$2,758	\$2,758
19	Plumbing				
20	Roof drain piping system	15,838	SF	\$0.35	\$5,490
21	Electrical				
22	Power for lights and other equipment	15,838	SF	\$0.87	\$13,722
23	Site Utilities				
24	Electrical and Water Service	1	LS	\$2,758	\$2,758
25	Total Module B Estimated Cost				\$118,222
26	Estimating Contingency		5%		\$5,900
27	Unforeseen Conditions Contingency		5%		\$5,900
28	2 Year Escallation Contingency		5%		\$5,900
29	City of Madison Contingency		8%		\$9,500
30					
31	A/E Fee Estimate		10%		\$14,500
32	Total Module Ó Estimated Cost				\$159,922

Module C Cost Estimate

Module C		Module Size		1,997 SF	
Line No.	Description of Work	Quantity	Unit Measure	Cost per Unit	Estimated Cost
1	Existing Conditions				
2	Demolition of roof structure	1,997	SF	\$1.51	\$3,019
3	Demolition of for new footing	3	EA	\$484	\$1,451
4	Demolition of CMU walls	1,997	SF	\$3.02	\$6,037
5	Concrete Repairs				
6	Column footing forms	48	SF	\$6.34	\$305
7	Column footing rebar	1	TONS	\$2,264	\$1,132
8	Patching of spalled concrete	4	EA	\$865	\$3,460
9	Footing Concrete	2	CY	\$205.97	\$377
10	New Concrete roof framing	1,997	SF	\$0.00	\$0
11	Masonry Restoration				
12	Repoint	0	SF		\$0
13	Full Depth Repoint	732	SF	\$24.36	\$17,840
14	1 Wythe Rebuild	0	SF		\$0
15	2 Wythe Rebuild	0	SF		\$0
16	2-1/2 Wythe Rebuild	0	SF		\$0
17	Replace concrete/sill band	0	LF		\$0
18	Crack to Catch	0	LF		\$0
19	Structural Steel				
20	New Roof Beams & Columns	1,997	SF	\$3.26	\$6,514
21	Structural Steel to support roof at removed walls	1,997	SF	\$2.45	\$4,885
22	Rough Carpentry				
23	Roof Framing DBL 2X10@16"OC, 5/8" PLYWD	1,997	SF	\$4.78	\$9,537
24	Existing ledgers will also need to be replaced. Where members are to be placed in masonry joist pockets, single LVL members of matching depth can be substituted for the double 2x10's.	1	LS	\$3,600	\$3,600

Module C Cost Estimate

Module C		Module Size		1,997 SF	
Line No.	Description of Work	Quantity	Unit Measure	Cost per Unit	Estimated Cost
25	Thermal and Moisture Protection				
26	Membrane roofing system	1,997	SF	\$9.77	\$19,505
27	Finishes				
28	Painting Steel Beam	1	LS	\$2,450	\$2,450
29	Plumbing				
30	Roof drain piping system	1,997	SF	\$2.44	\$4,876
31	Electrical				
32	Power for lights and other equipment	1,997	SF	\$6.10	\$12,190
33	Site Utilities				
34	Electrical and Water Service	1	LS	\$2,450	\$2,450
35	Total Module C Estimated Cost				\$99,628
36	Estimating Contingency		5%		\$5,000
37	Unforeseen Conditions Contingency		5%		\$5,000
38	2 Year Escallation Contingency		5%		\$5,000
39	City of Madison Contingency		8%		\$8,000
40					
41	A/E Fee Estimate		10%		\$12,300
42	Total Module Ô Estimated Cost				\$134,928

Module D Cost Estimate

Module D		Module Size		1,080 SF	
Line No.	Description of Work	Quantity	Unit Measure	Cost per Unit	Estimated Cost
1	Existing Conditions				
2	Remove loose & hanging debris from roof and floor	1,080	SF	\$0.60	\$653
3	Demolition of 2nd floor framing	1,080	SF	\$1.51	\$1,632
4	Demolition of Chimney and Salvage Brick	1	EA	\$2,418	\$2,418
5	Remove concrete vault cover and CMU walls	1	EA	\$8,057	\$8,057
6	Masonry				
7	Tooth walls together	24	LF	\$46.40	\$1,114
8	Masonry Restoration				
9	Repoint	0	SF		\$0
10	Full Depth Repoint	125	SF	\$24.36	\$3,041
11	1 Wythe Rebuild	0	SF		\$0
12	2 Wythe Rebuild	144	SF	\$33.89	\$4,871
13	2-1/2 Wythe Rebuild	297	SF	\$46.09	\$13,695
14	Replace concrete/sill band	0	LF		\$0
15	Crack to Catch	0	LF		\$0
16	Structural Steel				
17	New Structural floor system	1,080	SF	\$14	\$15,378
18	Install strong back bracing system	1	LS	\$4,396	\$4,396
19	W 8x10 vertical strong backs	96	LF	\$10.69	\$1,026
20	W14x34 horizontal beam	80	LF	\$35.04	\$2,803
21	Replace steel roof trusses	1,080	SF	\$18.99	\$20,504
22	Rough Carpentry				
23	new decking 5/8 plywood +backing	1,080	SF	\$3.78	\$4,082

Module D Cost Estimate

Module D		Module Size		1,080 SF	
Line No.	Description of Work	Quantity	Unit Measure	Cost per Unit	Estimated Cost
24	Thermal and Moisture Protection				
25	Membrane roofing system	1,080	SF	\$9.77	\$10,548
26	Finishes				
27	Painting Steel Beam	1	LS	\$1,325	\$1,325
28	Plumbing				
29	Roof drain piping system	1,080	SF	\$2.44	\$2,637
30	Electrical				
31	Power for lights and other equipment	1,080	SF	\$6.11	\$6,593
32	Site Utilities				
33	Electrical and Water Service	1	LS	\$1,325	\$1,325
34	Total Module D Estimated Cost				\$106,097
35	Estimating Contingency		5%		\$5,300
36	Unforeseen Conditions Contingency		5%		\$5,300
37	2 Year Escallation Contingency		5%		\$5,300
38	City of Madison Contingency		8%		\$8,500
39					
40	A/E Fee Estimate		10%		\$13,000
41	Total Module Ö Estimated Cost				\$143,497

Module E Cost Estimate

Module E		Module Size		3,392 SF	
Line No.	Description of Work	Quantity	Unit Measure	Cost per Unit	Estimated Cost
1	Existing Conditions				
2	Remove loose & hanging debris from roof and floor	3,392	SF	\$0.60	\$2,050
3	Demolition of roof structure	3,392	SF	\$2.02	\$6,835
4	Brace walls during roof removal	232	LF	\$104.15	\$24,164
5	Pit inside the space be cleaned, drainage holes cored in the bottom of the pit	1	EA	\$15,261	\$15,261
6	Concrete Repairs				
7	Concrete anchors at vertical supports	3	EA	\$720	\$2,160
8	Masonry				
9	Repair steel support masonry	1	EA	\$968	\$968
10	Tooth walls together	126	LF	\$56.16	\$7,077
11	Replace masonry jamb at one opening in the north wall	1	EA	\$2,442	\$2,442
12	Masonry Restoration				
13	Repoint	504	SF	\$21.67	\$10,917
14	Full Depth Repoint	90	SF	\$24.35	\$2,198
15	1 Wythe Rebuild	1,128	SF	\$30.46	\$34,375
16	2 Wythe Rebuild	643	SF	\$33.88	\$21,770
17	2-1/2 Wythe Rebuild	1,877	SF	\$46.09	\$86,530
18	Replace concrete/sill band	0	LF		\$0
19	Crack to Catch	147	LF	\$42.73	\$6,285
20	Structural Steel				
21	Install strong back bracing system	1	LS	\$8,790	\$8,790
22	W 8x10 vertical strong backs	252	LF	\$10.69	\$2,694
23	W14x34 horizontal beam	120	LF	\$35.03	\$4,204
24	Replace steel roof trusses	3,392	SF	\$18.99	\$64,396
25	Steel Angle 3x3x1/4 at roof perimeter	232	LF	\$12.25	\$2,842

Module E Cost Estimate

Module E		Module Size	3,392 SF		
Line No.	Description of Work	Quantity	Unit Measure	Cost per Unit	Estimated Cost
26	Rough Carpentry				
27	Roof Framing 2x10 - 16 in o.c. 5/8 plywood	3,392	SF	\$8.70	\$29,494
28	Thermal and Moisture Protection				
29	Membrane roofing system	3,392	SF	\$9.77	\$33,130
30	Finishes				
31	Painting Steel Beam	1	LS	\$4,162	\$4,162
32	Plumbing				
33	Roof drain piping system	3,392	SF	\$2.44	\$8,282
34	Electrical				
35	Power for lights and other equipment	3,392	SF	\$6.10	\$20,706
36	Site Utilities				
37	Electrical and Water Service	1	LS	\$4,162	\$4,162
38	Total Module E Estimated Cost				\$405,894
39	Estimating Contingency		5%		\$20,300
40	Unforeseen Conditions Contingency		5%		\$20,300
41	2 Year Escallation Contingency		5%		\$20,300
42	City of Madison Contingency		8%		\$32,500
43					
44	A/E Fee Estimate		10%		\$49,900
45	Total Module Ò Estimated Cost				\$549,194

Module F Cost Estimate

Module F

Module Size

3,145 SF

Line No.	Description of Work	Quantity	Unit Measure	Cost per Unit	Estimated Cost
1	Existing Conditions				
2	Remove loose & hanging debris from roof and floor	3,145	SF	\$0.60	\$1,901
3	Demolition of roof structure	3,145	SF	\$6.79	\$21,343
4	Demolition 2nd and 3rd floor wood framing	3,145	SF	\$3.02	\$9,507
5	Clean pit and core drain holes	1	EA	\$15,261	\$15,261
6	Remove collapsed steel beam	1	EA	\$4,941	\$4,941
7	Backfill pits with sand	1	EA	\$6,272	\$6,272
8	Concrete Repair				
9	Replace slab-on-grade	3,145	SF	\$4.79	\$15,078
10	Masonry Restoration				
11	Repoint	0	SF		\$0
12	Full Depth Repoint	0	SF		\$0
13	1 Wythe Rebuild	0	SF		\$0
14	2 Wythe Rebuild	624	SF	\$33.88	\$21,132
15	2-1/2 Wythe Rebuild	712	SF	\$46.09	\$32,815
16	Replace concrete/sill band	0	LF		\$0
17	Crack to Catch	0	LF		\$0
18	Structural Steel				
19	New structural steel framing	6,290	SF	\$14.24	\$89,567
20	Rough Carpentry				
21	Roof Framing 2x10 - 16 in o.c. 5/8 plywood	3,145	SF	\$8.70	\$27,346
22	Thermal and Moisture Protection				
23	Membrane roofing system	3,145	SF	\$9.77	\$30,718
24	Finishes				
25	Painting Steel Beam	1	LS	\$3,859	\$3,859

Module F Cost Estimate

Module F		Module Size		3,145 SF	
Line No.	Description of Work	Quantity	Unit Measure	Cost per Unit	Estimated Cost
26	Plumbing				
27	Roof drain piping system	3,145	SF	\$2.44	\$7,677
28	Electrical				
29	Power for lights and other equipment	3,145	SF	\$6.10	\$19,192
30	Site Utilities				
31	Electrical and Water Service	1	LS	\$3,858	\$3,858
32	Total Module F Estimated Cost				\$310,466
33	Estimating Contingency		5%		\$15,500
34	Unforeseen Conditions Contingency		5%		\$15,500
35	2 Year Escallation Contingency		5%		\$15,500
36	City of Madison Contingency		8%		\$24,800
37					
38	A/E Fee Estimate		10%		\$38,200
39	Total Module Ø Estimated Cost				\$419,966

Module G Cost Estimate

Module G		Module Size		1,595 SF	
Line No.	Description of Work	Quantity	Unit Measure	Cost per Unit	Estimated Cost
1	Existing Conditions				
2	Remove loose & hanging debris from roof and floor	1,595	SF	\$0.60	\$964
3	Demolition of roof structure	1,595	SF	\$1.51	\$2,411
4	Demolition 1st floor wood framing	1,595	SF	\$1.51	\$2,411
5	Demolition of steel roof structure	1,595	SF	\$2.01	\$3,214
6	Brace walls during roof removal	168	LF	\$102	\$17,070
7	Large pit in this area cleaned out	1	EA	\$15,261	\$15,261
8	Masonry Restoration				
9	Repoint	0	SF		\$0
10	Full Depth Repoint	0	SF		\$0
11	1 Wythe Rebuild	1,411	SF	\$30.46	\$42,967
12	2 Wythe Rebuild	223	SF	\$33.88	\$7,565
13	2-1/2 Wythe Rebuild	498	SF	\$46.09	\$22,965
14	Replace concrete/sill band	0	LF		\$0
15	Crack to Catch	0	LF		\$0
16	Structural Steel				
17	Replace steel roof trusses	1,595	SF	\$18.98	\$30,281
18	Structural Steel Allowance	1	EA	\$12,209	\$12,209
19	Steel Angle 3x3x1/4 at roof perimeter	168	LF	\$12.24	\$2,057
20	Rough Carpentry				
21	Roof Framing 2x10 - 16 in o.c. 5/8 plywood	1,595	SF	\$8.69	\$13,868
22	2nd & 3rd floor framing 2x12 - 12 in o.c. 3/4 T&G plywood	1,276	SF	\$9.66	\$12,327
23	1st floor framing 2x12 - 12 in o.c. 3/4 T&G plywood	1,595	SF	\$9.66	\$15,409

Module G Cost Estimate

Module G		Module Size		1,595 SF	
Line No.	Description of Work	Quantity	Unit Measure	Cost per Unit	Estimated Cost
24	Thermal and Moisture Protection				
25	Membrane roofing system	1,595	SF	\$9.76	\$15,578
26	Finishes				
27	Painting Steel Beam	1	LS	\$1,957	\$1,957
28	Plumbing				
29	Roof drain piping system	1,595	SF	\$2.44	\$3,895
30	Electrical				
31	Power for lights and other equipment	1,595	SF	\$6.10	\$9,737
32	Site Utilities				
33	Electrical and Water Service	1	LS	\$1,957	\$1,957
34	Total Module G Estimated Cost				\$234,104
35	Estimating Contingency		5%		\$11,700
36	Unforeseen Conditions Contingency		5%		\$11,700
37	2 Year Escallation Contingency		5%		\$11,700
38	City of Madison Contingency		8%		\$18,700
39					
40	A/E Fee Estimate		10%		\$28,800
41	Total Module Õ Estimated Cost				\$316,704

Module H Cost Estimate

Module H

Module Size

2,202 SF

Line No.	Description of Work	Quantity	Unit Measure	Cost per Unit	Estimated Cost
1	Existing Conditions				
2	Remove loose & hanging debris from roof and floor	2,202	SF	\$0.60	\$1,331
3	Demolition of concrete slab and steel beams	2,202	SF	\$6.79	\$14,943
4	Clean pit and core drain holes	1	EA	\$15,261	\$15,261
5	Backfill pits with sand	1	EA	\$6,272	\$6,272
6	Demolition of metal deck and beam	330	SF	\$4.10	\$1,354
7	Concrete Repair				
8	Replace slab-on-grade	2,202	SF	\$8.54	\$18,810
9	Masonry				
10	Tooth walls together	84	LF	\$56.16	\$4,717
11	Shore walls during construction	1	EA	\$19,344	\$19,344
12	Masonry Restoration				
13	Repoint	243	SF	\$21.67	\$5,261
14	Full Depth Repoint	0	SF		\$0
15	1 Wythe Rebuild	0	SF		\$0
16	2 Wythe Rebuild	760	SF	\$33.88	\$25,740
17	2-1/2 Wythe Rebuild	839	SF	\$46.09	\$38,669
18	Replace concrete/sill band	119	LF	\$91.56	\$10,890
19	Crack to Catch	0	LF		\$0
20	Structural Steel				
21	New structural steel framing	380	SF	\$6.43	\$2,444
22	Thermal and Moisture Protection				
23	Membrane roofing system	2,202	SF	\$9.77	\$21,507
24	Finishes				
25	Painting Steel Beam	1	LS	\$2,702	\$2,702
26	Plumbing				

Module H Cost Estimate

Module H		Module Size		2,202 SF	
Line No.	Description of Work	Quantity	Unit Measure	Cost per Unit	Estimated Cost
1	Existing Conditions				
27	Roof drain piping system	2,202	SF	\$2.44	\$5,377
28	Electrical				
29	Power for lights and other equipment	2,202	SF	\$6.10	\$13,442
30	Site Utilities				
31	Electrical and Water Service	1	LS	\$2,702	\$2,702
32	Total Module H Estimated Cost				\$210,765
33	Estimating Contingency		5%		\$10,500
34	Unforeseen Conditions Contingency		5%		\$10,500
35	2 Year Escallation Contingency		5%		\$10,500
36	City of Madison Contingency		8%		\$16,900
37					
38	A/E Fee Estimate		10%		\$25,900
39	Total Module P Estimated Cost				\$285,065

Module I Cost Estimate

Module I		Module Size		1,656 SF	
Line No.	Description of Work	Quantity	Unit Measure	Cost per Unit	Estimated Cost
1	Existing Conditions				
2	Remove loose & hanging debris from roof and floor	1,656	SF	\$0.60	\$1,001
3	Demolition of roof structure	1,656	SF	\$1.51	\$2,503
4	Masonry Restoration				
5	Repoint	0	SF		\$0
6	Full Depth Repoint	265	SF	\$24.36	\$6,465
7	1 Wythe Rebuild	1,214	SF	\$30.46	\$36,979
8	2 Wythe Rebuild	0	SF		\$0
9	2-1/2 Wythe Rebuild	387	SF	\$46.09	\$17,832
10	Replace concrete/sill band	0	LF		\$0
11	Crack to Catch	0	LF		\$0
12	Thermal and Moisture Protection				
13	Membrane roofing system	1,656	SF	\$9.77	\$16,175
14	Finishes				
15	Painting Steel Beam	1	LS	\$2,032	\$2,032
16	Plumbing				
17	Roof drain piping system	1,656	SF	\$2.44	\$4,044
18	Electrical				
19	Power for lights and other equipment	1,656	SF	\$6.10	\$10,109
20	Site Utilities				
21	Electrical and Water Service	1	LS	\$2,032	\$2,032
22	Total Module I Estimated Cost				\$99,172
23	Estimating Contingency		5%		\$5,000
24	Unforeseen Conditions Contingency		5%		\$5,000
25	2 Year Escallation Contingency		5%		\$5,000
26	City of Madison Contingency		8%		\$7,900
27					
28	A/E Fee Estimate		10%		\$12,200
29	Total Module Q Estimated Cost				\$134,272

Module J Cost Estimate

Module J		Module Size		16,599 SF	
Line No.	Description of Work	Quantity	Unit Measure	Cost per Unit	Estimated Cost
1	Existing Conditions				
2	Remove loose & hanging debris from roof and floor	16,599	SF	\$0.60	\$10,036
3	Demolition of roof structure	16,599	SF	\$1.51	\$25,090
4	Concrete Repair				
5	Replace column pier	64	SF	\$30.99	\$1,983
6	Masonry Restoration				
7	Repoint	0	SF		\$0
8	Full Depth Repoint	637	SF	\$24.36	\$15,528
9	1 Wythe Rebuild	3,573	SF	\$30.46	\$108,825
10	2 Wythe Rebuild	478	SF	\$33.88	\$16,206
11	2-1/2 Wythe Rebuild	3,717	SF	\$46.09	\$171,299
12	Replace concrete/sill band	0	LF		\$0
13	Crack to Catch	146	LF	\$42.73	\$6,255
14	Structural Steel				
15	Reset roof beams in masonry pocket	6	EA	\$2,642	\$15,852
16	Replace steel columns	2	EA	\$1,265	\$2,530
17	Steel Angle 3x3x1/4 at roof perimeter	512	LF	\$12.25	\$6,271
18	Rough Carpentry				
19	Roof Framing 2x10 - 16 in o.c. 5/8 plywood	16,599	SF	\$8.70	\$144,340
20	Thermal and Moisture Protection				
21	Membrane roofing system	16,599	SF	\$9.77	\$162,134
22	Finishes				
23	Painting Steel Beam	1	LS	\$20,367	\$20,367
24	Plumbing				
25	Roof drain piping system	16,599	SF	\$2.44	\$40,531
26	Electrical				
27	Power for lights and other equipment	16,599	SF	\$6.10	\$101,328
28	Site Utilities				
29	Electrical and Water Service	1	LS	\$20,367	\$20,367
30	Total Module J Estimated Cost				\$868,941

Module J Cost Estimate

Module J		Module Size		16,599 SF	
Line No.	Description of Work	Quantity	Unit Measure	Cost per Unit	Estimated Cost
31	Estimating Contingency		5%		\$43,400
32	Unforeseen Conditions Contingency		5%		\$43,400
33	2 Year Escallation Contingency		5%		\$43,400
34	City of Madison Contingency		8%		\$69,500
35					
36	A/E Fee Estimate		10%		\$106,900
37	Total Module J Estimated Cost				\$1,175,541

Section A.4

Sightline LLC Elevations

A.4.1

Exterior

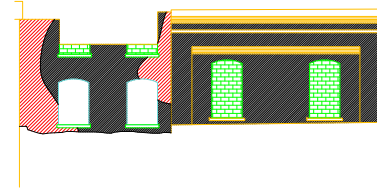
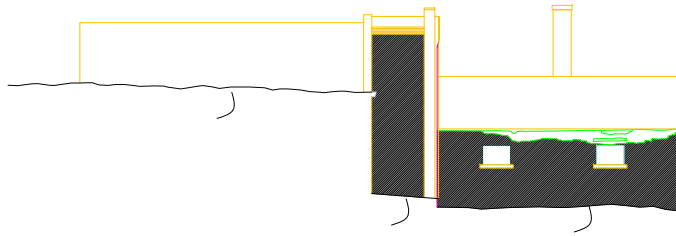

SCAN LEGEND

- Closed Opening
- 0 Inch = Surface closest to you.
- 1 Inch = Surface 1 inch from you.
- 2 Inch = Surface 2 inches from you.
- 3 Inch = Surface 3 inches from you.
- 4 Inch = Surface 4 inches from you.
- 5 Inch = Surface 5 inches from you.
- 6 Inch = Surface 6 inches from you.
- 7 Inch = Surface 7 inches from you.
- 8 Inch = Surface 8 inches from you.
- 9 Inch = Surface 9 inches from you.
- 10 Inch = Surface 10 inches from you.
- Topography line

4 SOUTH ELEV. EXTERIOR
Scale: 1/32"=1'-0" SOUTH ELEVATION @D & E

5 WEST ELEV. EXTERIOR
Scale: 1/32"=1'-0" WEST ELEVATION @H & I

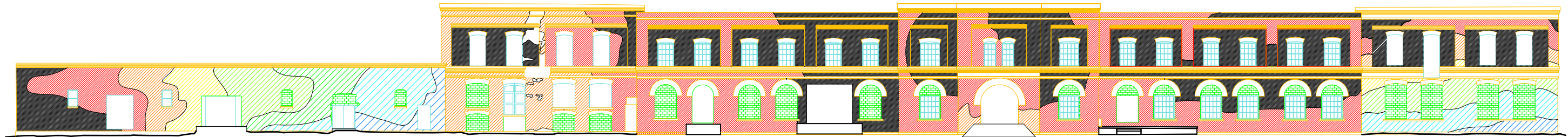

3 SOUTH ELEV. EXTERIOR
Scale: 1/32"=1'-0"

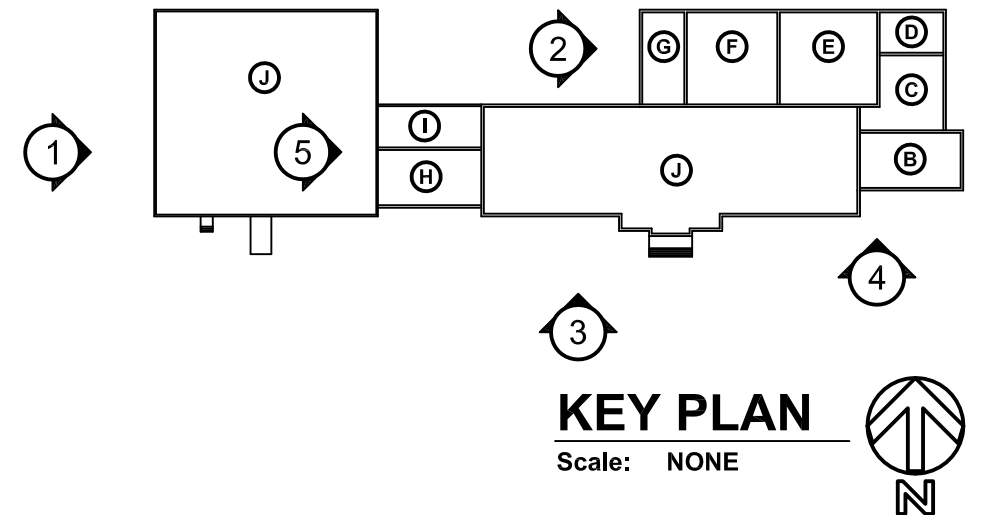
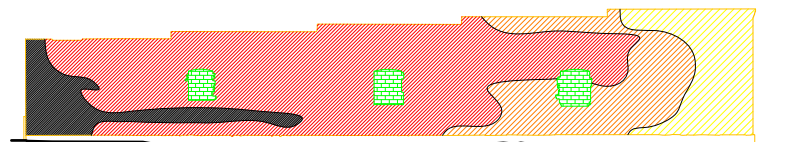
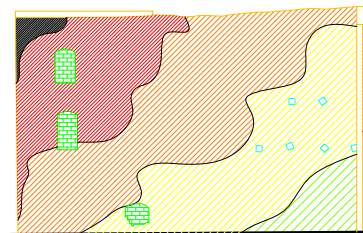

2 WEST ELEV. EXTERIOR
Scale: 1/32"=1'-0" WEST ELEVATION @G

1 WEST ELEV. EXTERIOR
Scale: 1/32"=1'-0" WEST ELEVATION @J

KEY PLAN
Scale: NONE

SCAN LEGEND

-  Closed Opening
-  0 Inch = Surface closest to you.
-  1 Inch = Surface 1 inch from you.
-  2 Inch = Surface 2 inches from you.
-  3 Inch = Surface 3 inches from you.
-  4 Inch = Surface 4 inches from you.
-  5 Inch = Surface 5 inches from you.
-  6 Inch = Surface 6 inches from you.
-  7 Inch = Surface 7 inches from you.
-  8 Inch = Surface 8 inches from you.
-  9 Inch = Surface 9 inches from you.
-  10 Inch = Surface 10 inches from you.
-  Topography line

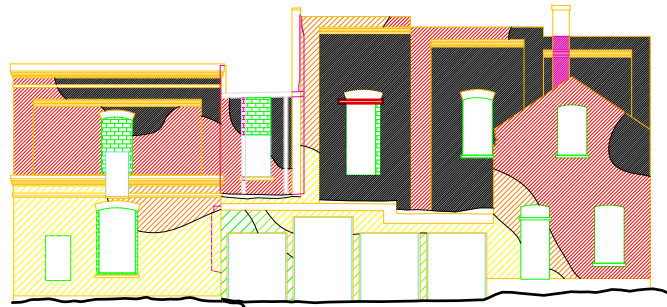

8 EAST ELEV. EXTERIOR
Scale: 1/32"=1'-0"

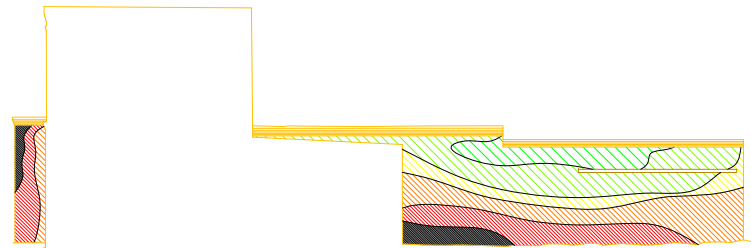

9 EAST ELEV. EXTERIOR
Scale: 1/32"=1'-0" EAST ELEVATION @J

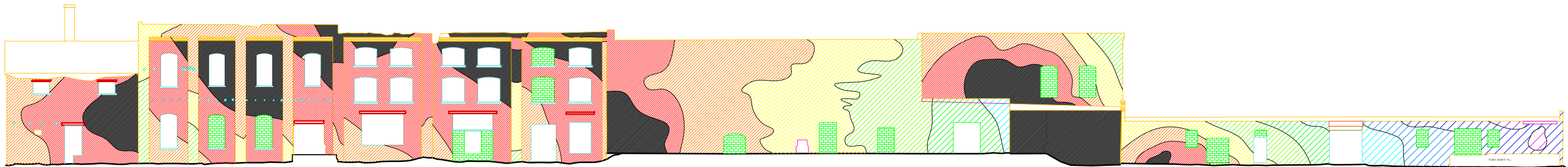

7 NORTH ELEV. EXTERIOR
Scale: 1/32"=1'-0"

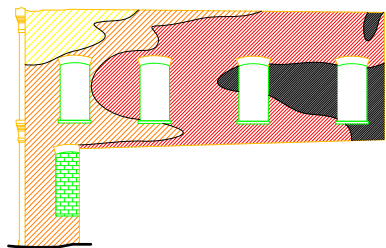

6 NORTH ELEV. EXTERIOR
Scale: 1/32"=1'-0" NORTH ELEVATION @B

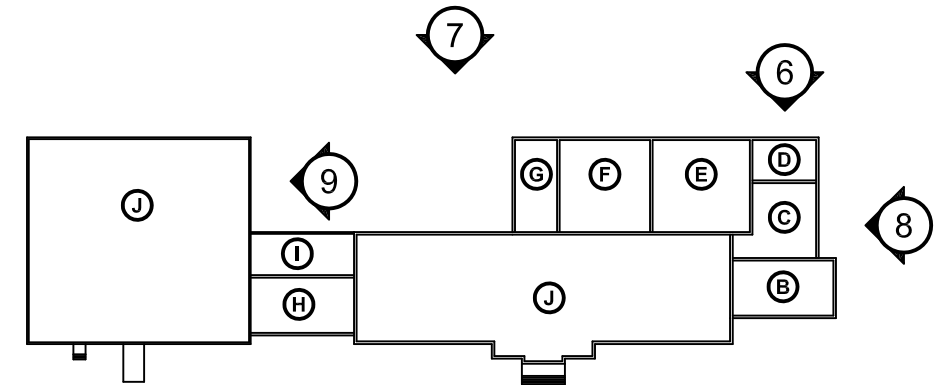

KEY PLAN
Scale: NONE



A.4.2

Interior

SCAN LEGEND

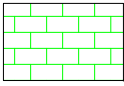

CLOSED OPENING

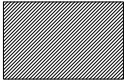

0 INCH = SURFACE CLOSEST TO YOU.

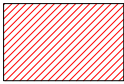

1 INCH = SURFACE 1 INCH FROM YOU.



2 INCH = SURFACE 2 INCHES FROM YOU.

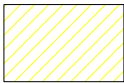

3 INCH = SURFACE 3 INCHES FROM YOU.

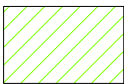

4 INCH = SURFACE 4 INCHES FROM YOU.

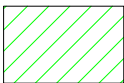

5 INCH = SURFACE 5 INCHES FROM YOU.

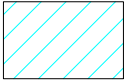

6 INCH = SURFACE 6 INCHES FROM YOU.

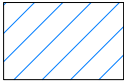

7 INCH = SURFACE 7 INCHES FROM YOU.

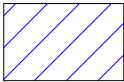

8 INCH = SURFACE 8 INCHES FROM YOU.

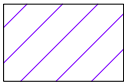

9 INCH = SURFACE 9 INCHES FROM YOU.

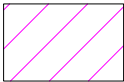

10 INCH = SURFACE 10 INCHES FROM YOU.



TOPOGRAPHY LINE



LASER SCAN ANALYSIS ELEVATIONS: SCAN LEGEND

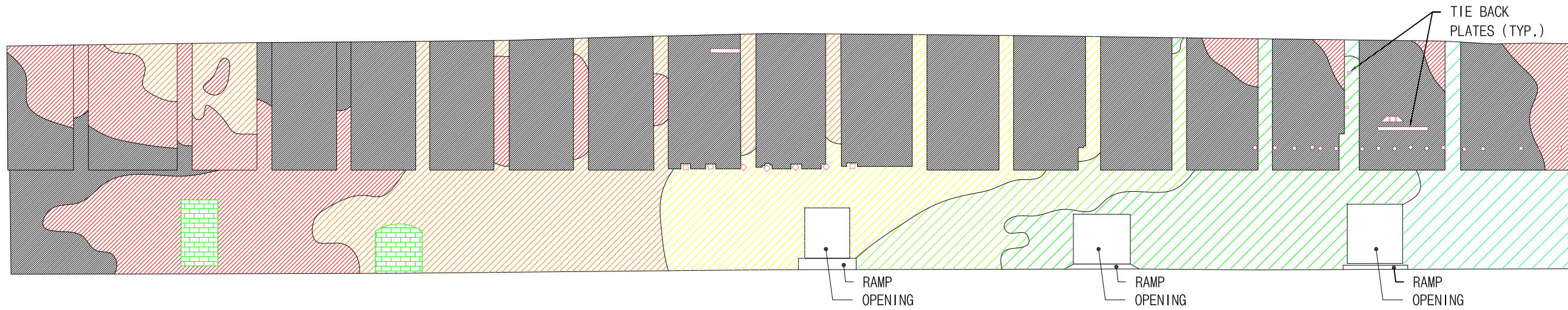

4 NORTH ELEV. MODULE A
 Scale: 1/16"=1'-0"

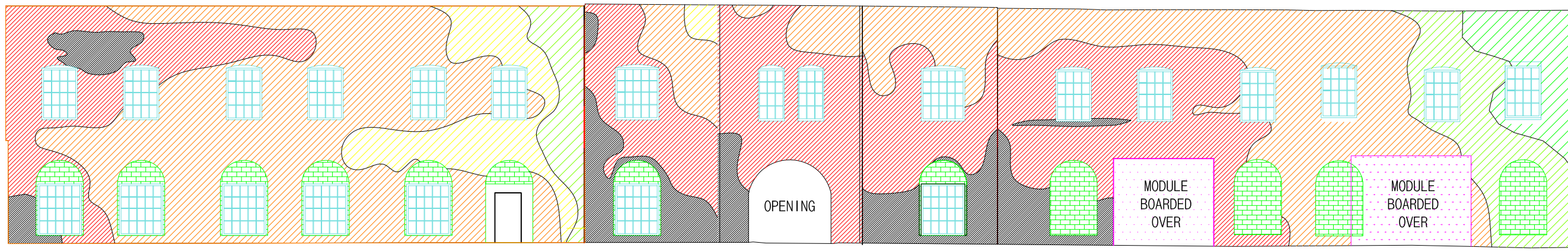

3 SOUTH ELEV. MODULE A
 Scale: 1/16"=1'-0"

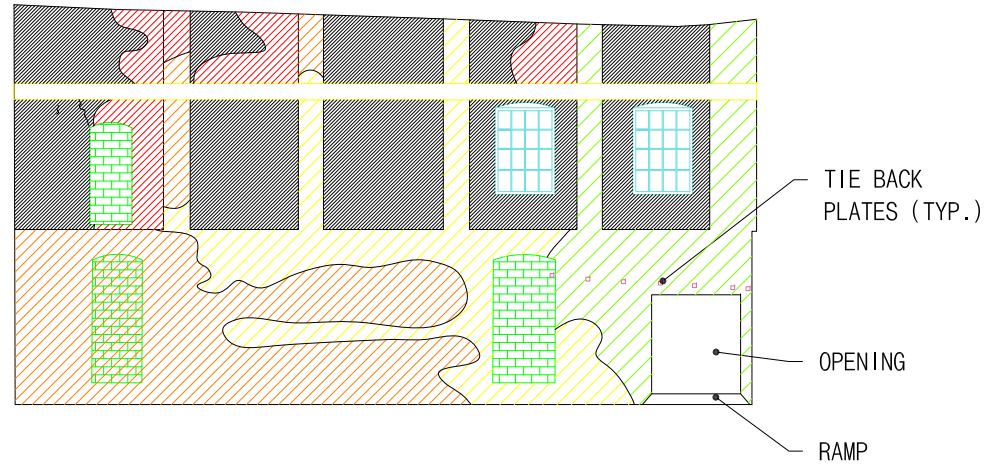

1 WEST ELEV. MODULE A
 Scale: 1/16"=1'-0"

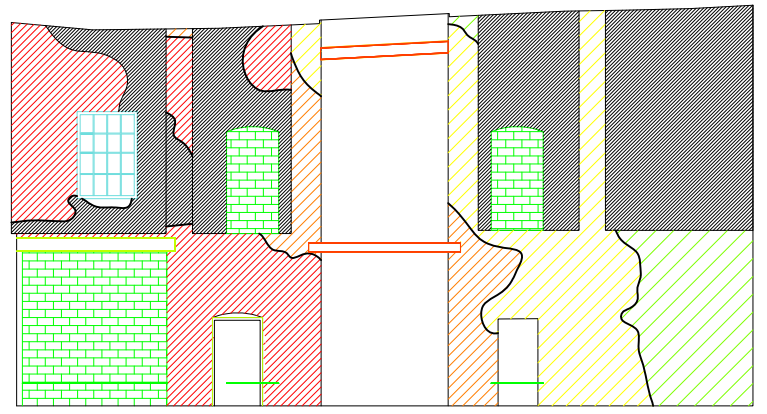

2 EAST ELEV. MODULE A
 Scale: 1/16"=1'-0"

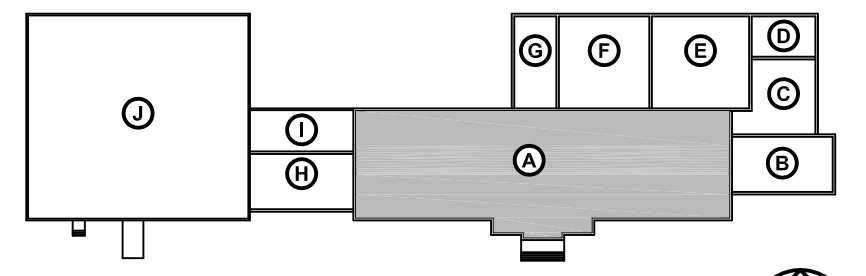

KEY PLAN
 Scale: NONE

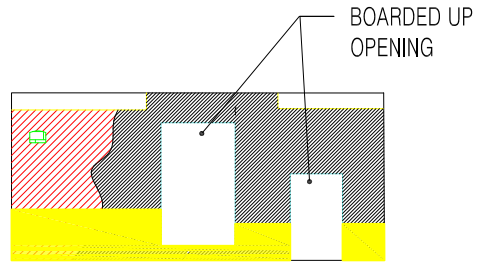

5 EAST ELEV. MODULE B

Scale: 1/16"=1'-0"

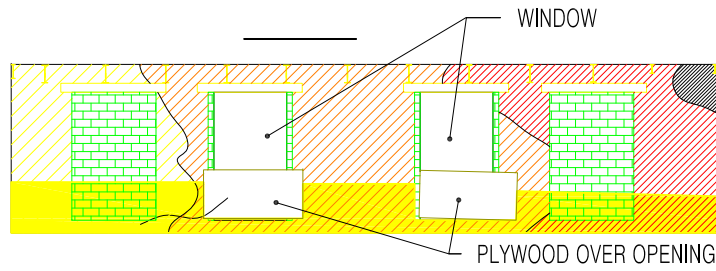

4 SOUTH ELEV. MODULE B

Scale: 1/16"=1'-0"

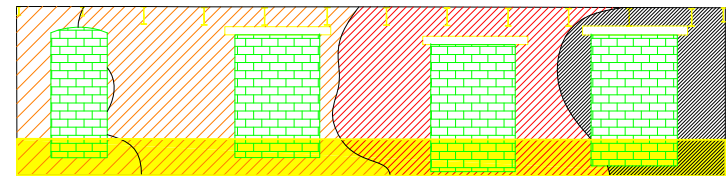

3 NORTH ELEV. MODULE B

Scale: 1/16"=1'-0"

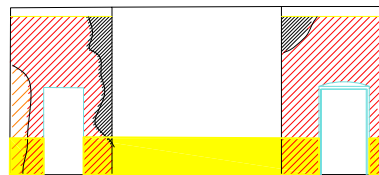

1 WEST ELEV. MODULE B

Scale: 1/16"=1'-0"

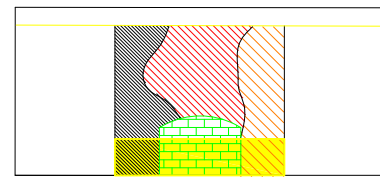

4 MIDWALL ELEV. MODULE B

Scale: 1/16"=1'-0"

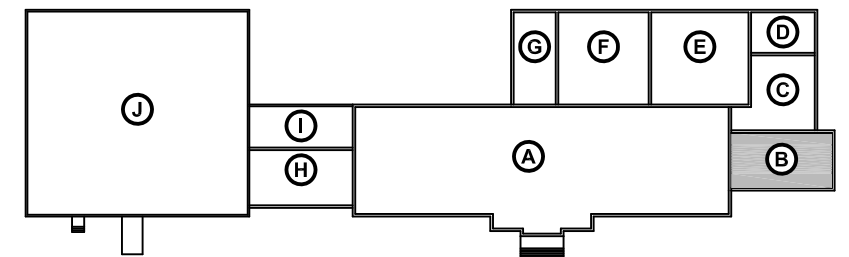

KEY PLAN
Scale: NONE



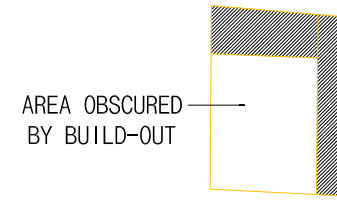
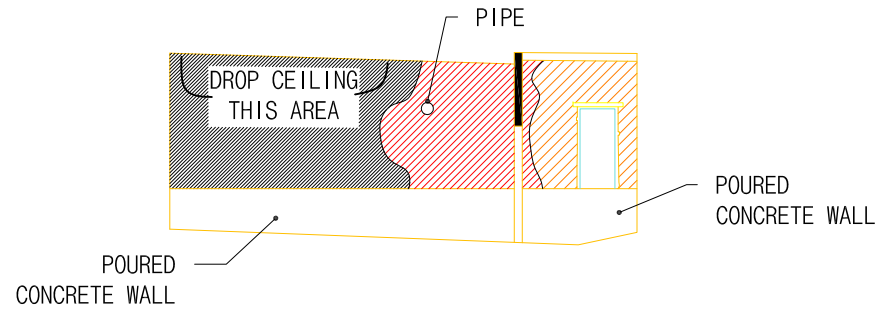

6 NORTH ELEV. MODULE C
Scale: 1/16"=1'-0"

5 NORTH MID-WALL ELEV. MODULE C
Scale: 1/16"=1'-0"

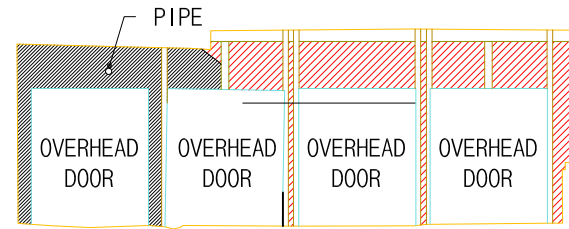
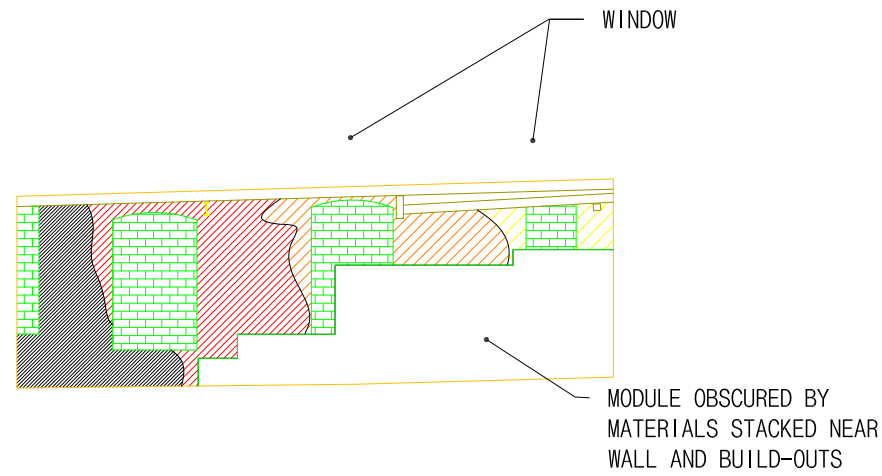

4 SOUTH ELEV. MODULE C
Scale: 1/16"=1'-0"

3 EAST ELEV. MODULE C
Scale: 1/16"=1'-0"

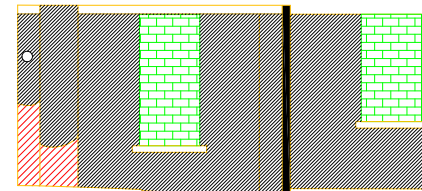

2 WEST MOST ELEV. MODULE C
Scale: 1/16"=1'-0"

1 WEST ELEV. MODULE C
Scale: 1/16"=1'-0"

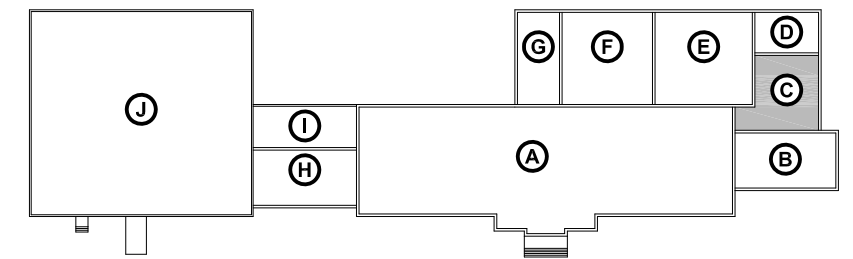

KEY PLAN
Scale: NONE

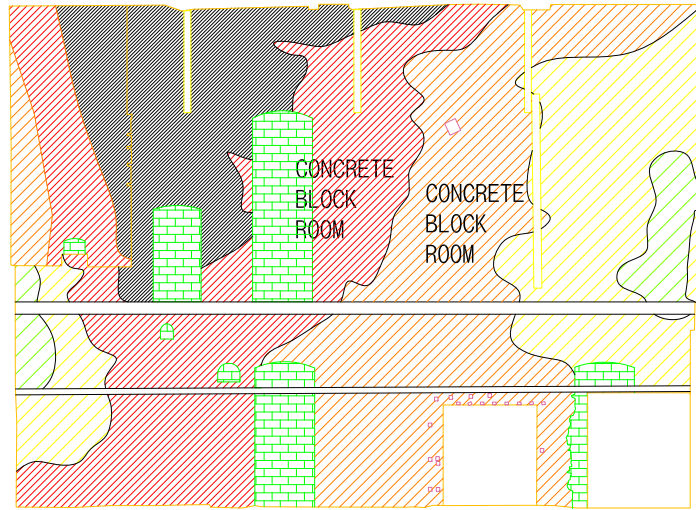

3 SOUTH ELEV. MODULE E
Scale: 1/16"=1'-0"

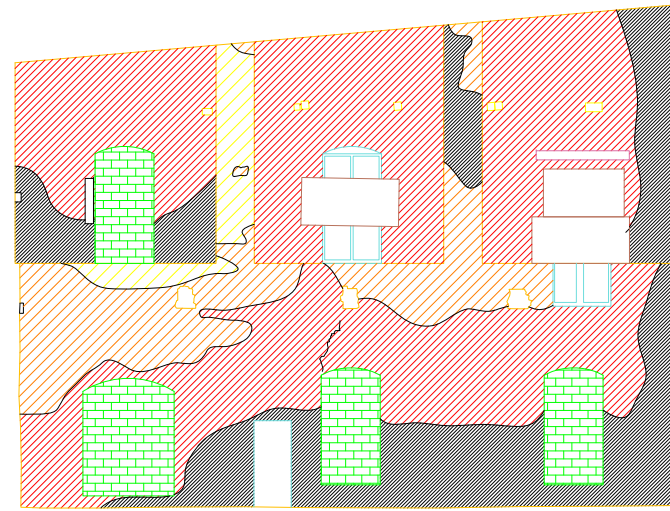

4 EAST ELEV. MODULE E
Scale: 1/16"=1'-0"

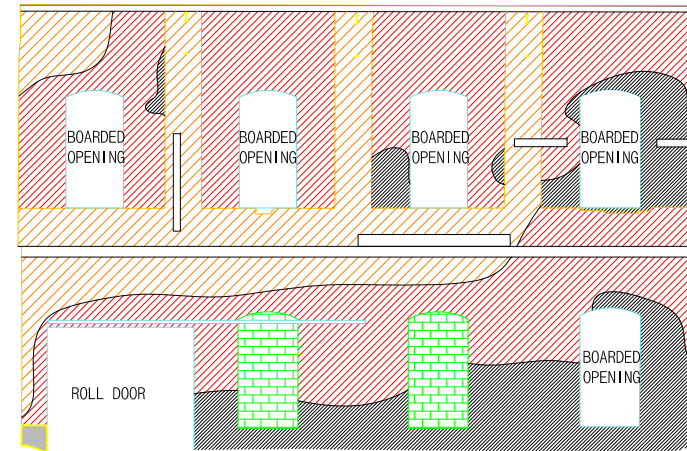

2 NORTH ELEV. MODULE E
Scale: 1/16"=1'-0"

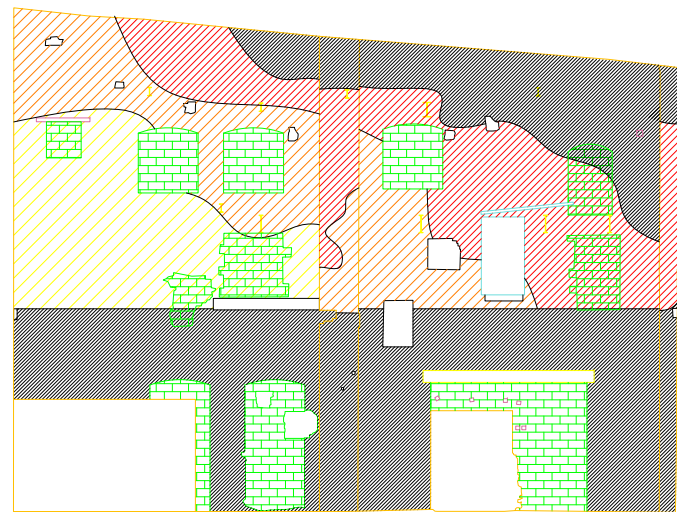

1 WEST ELEV. MODULE E
Scale: 1/16"=1'-0"

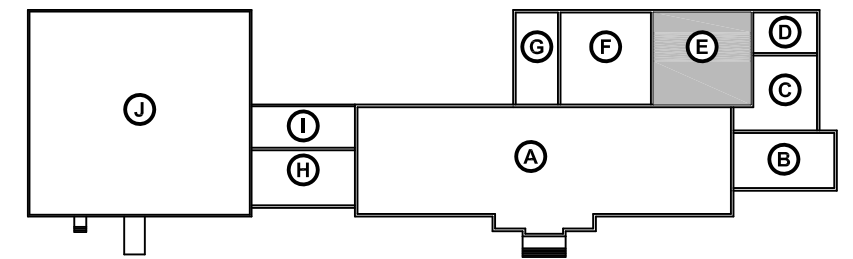

KEY PLAN
Scale: NONE

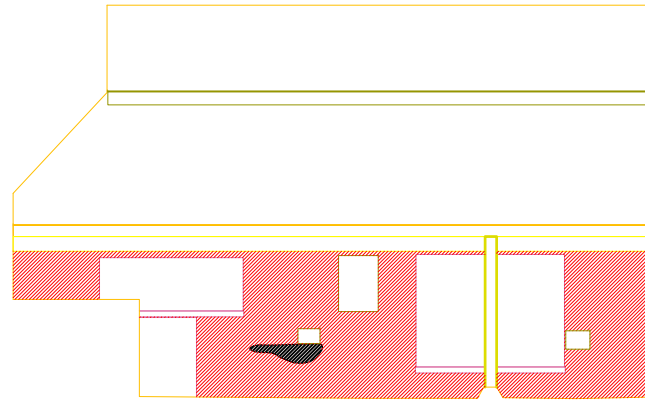

4 NORTH ELEV. MODULE F
Scale: 1/16"=1'-0"

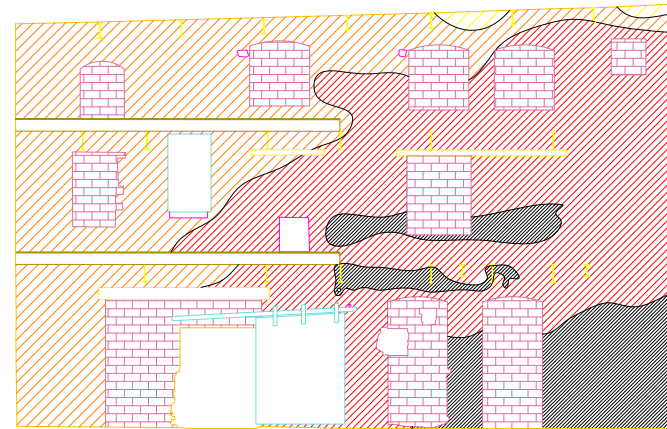

3 EAST ELEV. MODULE F
Scale: 1/16"=1'-0"

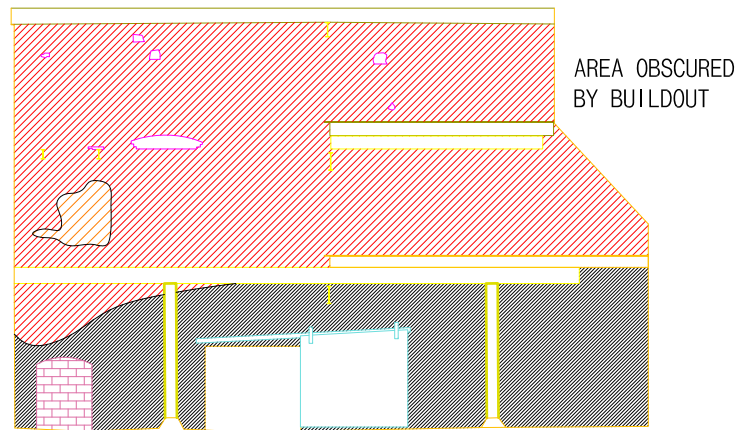

2 SOUTH ELEV. MODULE F
Scale: 1/16"=1'-0"

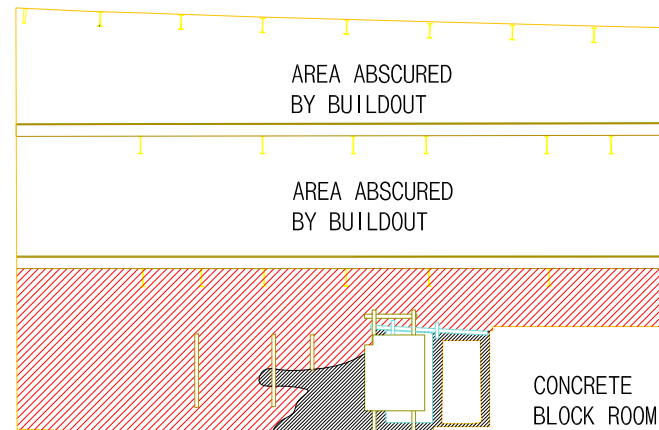

1 WEST ELEV. MODULE F
Scale: 1/16"=1'-0"

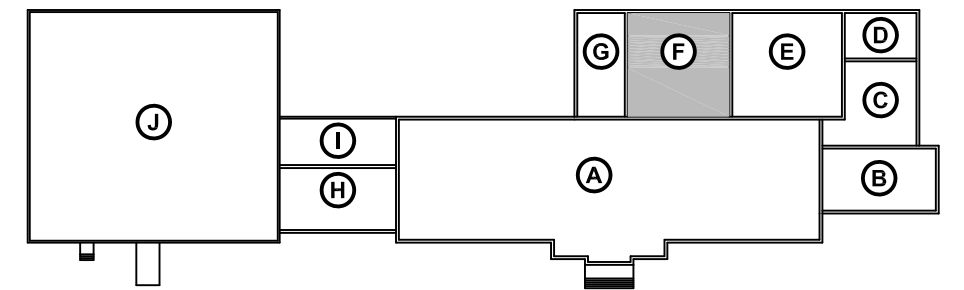

KEY PLAN
Scale: NONE

SCAN DATA OF THIS ROOM IS LIMITED-SCANNING OCCURRED FROM 2 DOORWAYS

COLLAPSED FLOOR

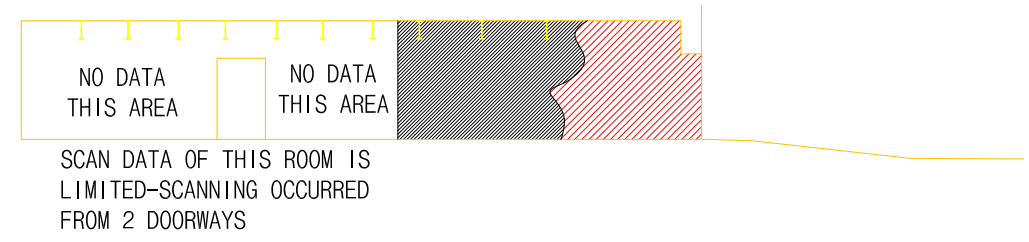

4 NORTH ELEV. MODULE G
Scale: 1/16"=1'-0"

3 EAST ELEV. MODULE G
Scale: 1/16"=1'-0"

NO DATA THIS AREA

SCAN DATA OF THIS ROOM IS LIMITED-SCANNING OCCURRED FROM 2 DOORWAYS

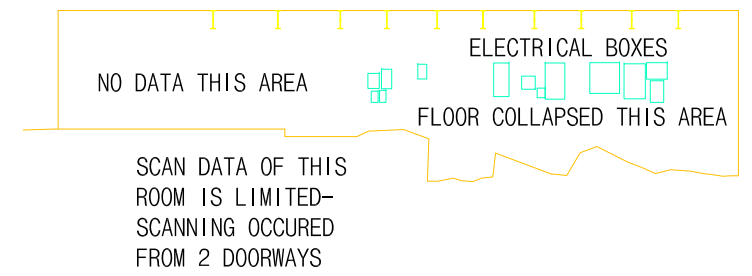

2 SOUTH ELEV. MODULE G
Scale: 1/16"=1'-0"

1 WEST ELEV. MODULE G
Scale: 1/16"=1'-0"

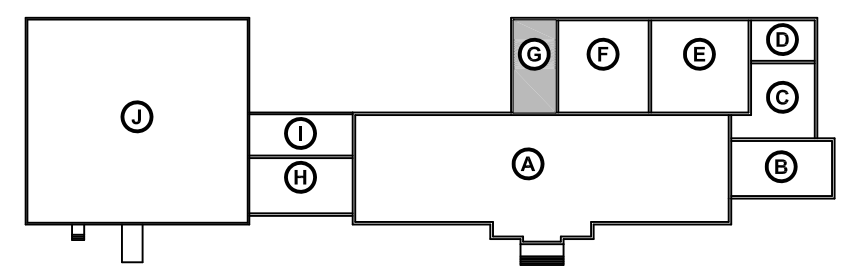

KEY PLAN
Scale: NONE

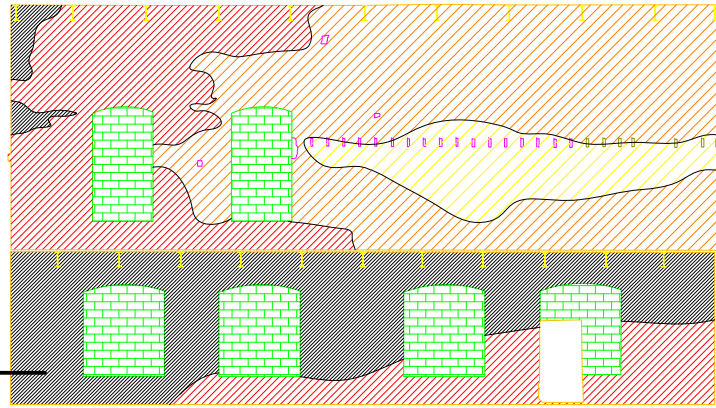

3 NORTH ELEV. MODULE H
Scale: 1/16"=1'-0"

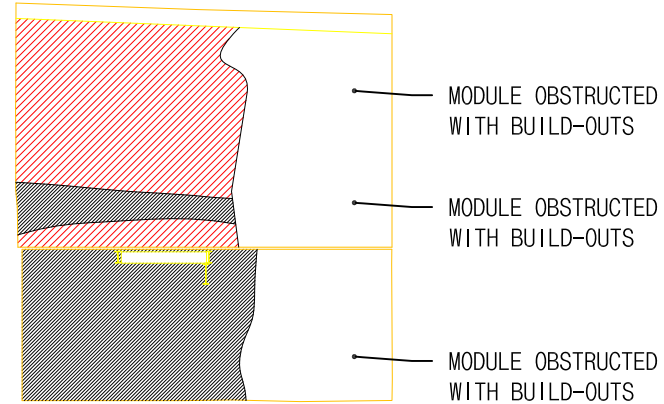

4 EAST ELEV. MODULE H
Scale: 1/16"=1'-0"

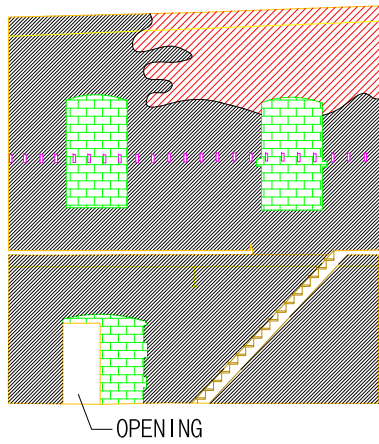

1 WEST ELEV. MODULE H
Scale: 1/16"=1'-0"

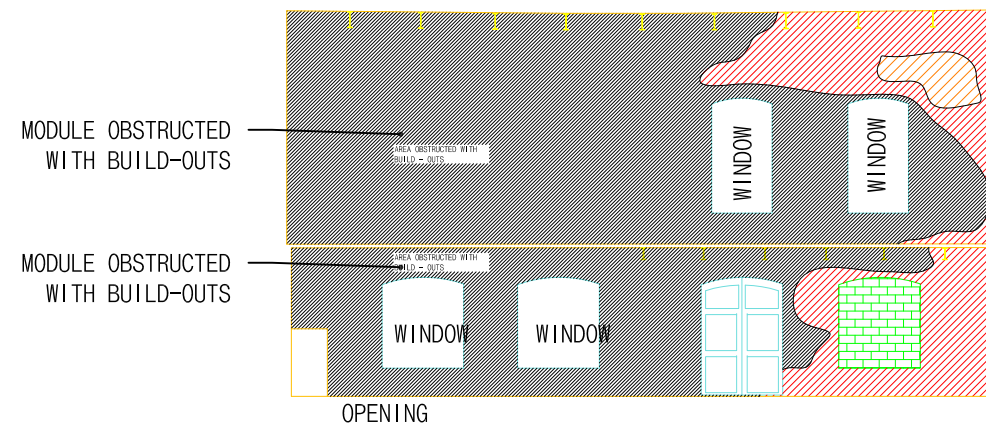

2 SOUTH ELEV. MODULE H
Scale: 1/16"=1'-0"

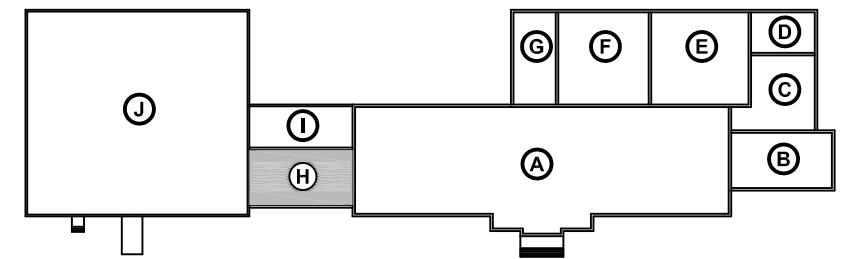

KEY PLAN
Scale: NONE

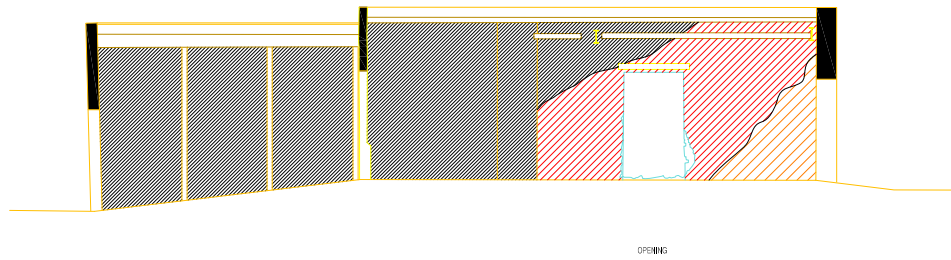

5 NORTH ELEV. MODULE I
Scale: 1/16"=1'-0"

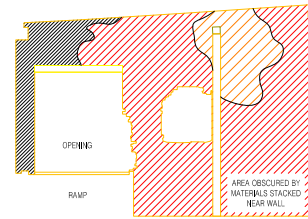

6 MIDWALL ELEV. EAST MODULE I
Scale: 1/16"=1'-0"

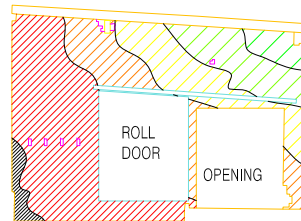

2 WEST ELEV. MODULE I
Scale: 1/16"=1'-0"

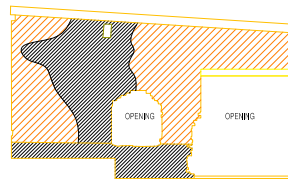

3 MIDWALL ELEV. WEST MODULE I
Scale: 1/16"=1'-0"

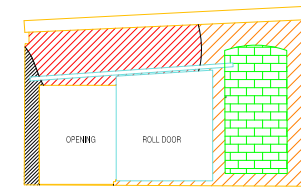

4 EAST ELEV. MODULE I
Scale: 1/16"=1'-0"

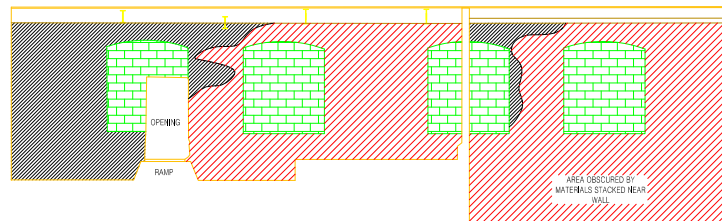

1 SOUTH ELEV. MODULE I
Scale: 1/16"=1'-0"

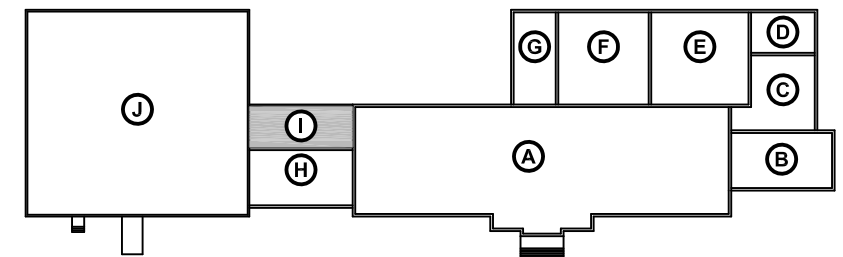

KEY PLAN
Scale: NONE

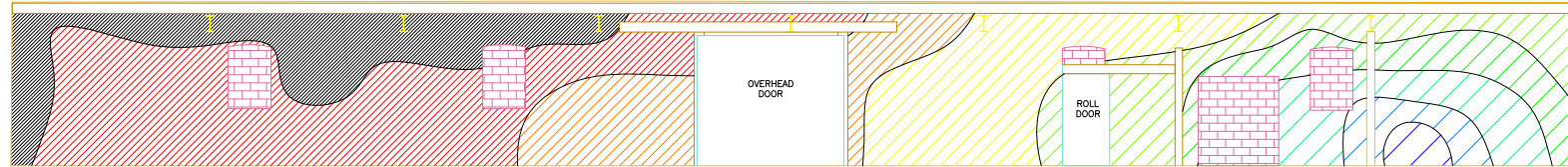

MUCH OF THE BASE OF THIS WALL WAS
OBSCURRED BY MATERIALS STACKED IN
FRONT OF IT

MUCH OF THE BASE OF THIS WALL WAS
OBSCURRED BY MATERIALS STACKED IN
FRONT OF IT

4 NORTH ELEV. MODULE J
Scale: 1/16"=1'-0"

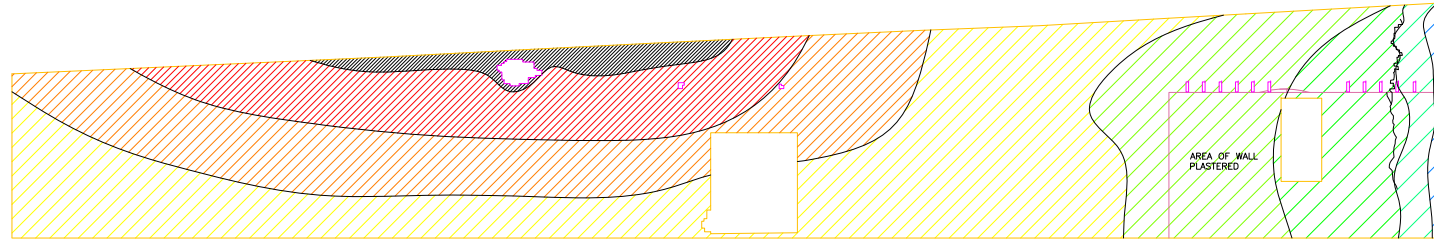

MUCH OF THE BASE OF THIS WALL WAS
OBSCURRED BY MATERIALS STACKED
IN FRONT OF IT

MUCH OF THE BASE OF THIS WALL WAS
OBSCURRED BY MATERIALS STACKED IN
FRONT OF IT

3 EAST ELEV. MODULE J
Scale: 1/16"=1'-0"

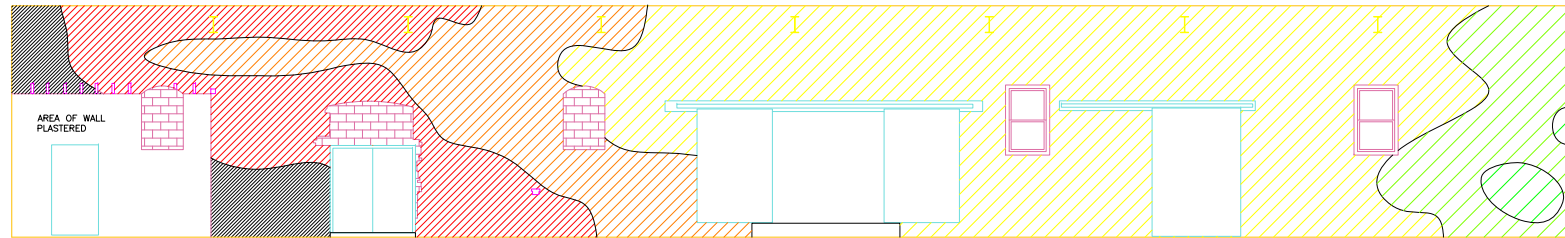

2 SOUTH ELEV. MODULE J
Scale: 1/16"=1'-0"

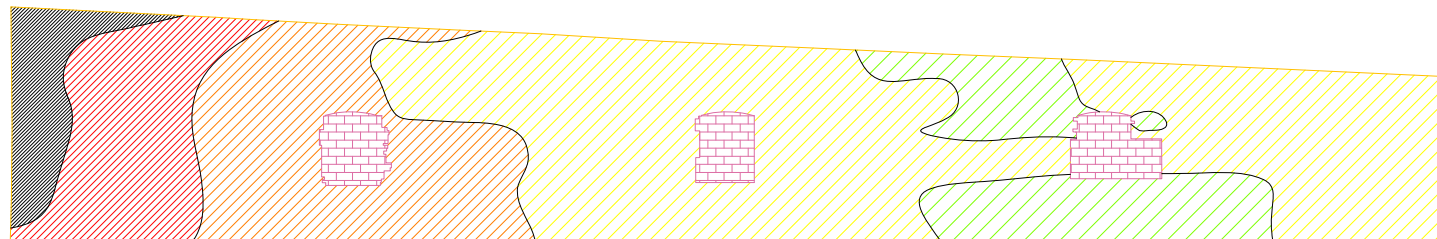

1 WEST ELEV. MODULE J
Scale: 1/16"=1'-0"

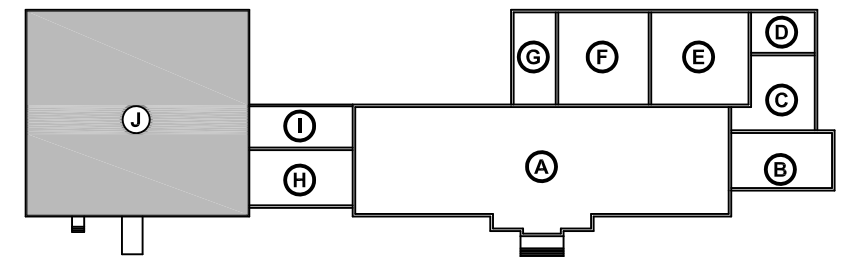

KEY PLAN
Scale: NONE



A.5

Glossary

Glossary

A

Alteration: Any act or process that changes one or more of the exterior architectural features of a structure, including, but not limited to, the erection, construction, reconstruction, addition, sand blasting, water blasting, chemical cleaning, chemical stripping, or removal of any structure, but not including changes to the color of exterior paint.

Appropriate: Especially suitable or compatible.

Arch: Curved construction which spans an opening and supports the weight above it.

B

Bracing: Material such as wood or steel that holds or fastens two or more parts together, or in place, or that steadies or holds something else erect.

Bed Joint: Horizontal mortar joint that bonds brick masonry together.

Beam: A horizontal or inclined structural member spanning a distance between two or more supports and carrying vertical loads.

Bearing wall: Any wall supporting a floor or the roof of a building.

Bottom Chord: A horizontal or inclined member that establishes the lower edge of a truss. Usually carrying combined tension and bending stresses.

C

Character: Distinctive traits or qualities and attributes in any structure, site, street or district.

Column: A circular or square free standing vertical structural member.

Compatible: In harmony with location and surroundings.

Configuration: The arrangement of elements and details on a building or structure which help to define its character.

Collar Joint: The vertical, longitudinal joint between wythes of masonry.

Context: The setting in which a historic element, site, structure, street, or district exists.

Coping: A protective cap, top, or cover of a wall parapet, commonly sloping to protect masonry from water

Cornice: A crowing projection or projecting molding that tops the wall surface.

D

Dead load: Includes loads that are relatively constant over time, including the weight of the structure itself, and immovable fixtures such as walls, plaster or carpet.

Deflection: The displacement of a structural element under load.

E

Eave: The projecting overhang at the lower edge of a roof.

Element: A material part or detail of a site, structure, street, or district.

Elevation: A drawing of a wall (exterior or interior).

Engaged column: Attached (or apparently attached) to a wall by being partly embedded or bonded to it.

F

Façade: Any one of the external walls of a building.

Fascia: The flat horizontal projection from the face of the exterior wall under the roof overhang.

Fenestration: Refers to the design and/or disposition of openings in a building or wall envelope. Fenestration products typically include: windows, doors, louvers, vents, etc.

Flashing: Strips of sheet metal bent to fit the angle between any two roof surfaces or between the roof and any projection, such as a chimney or cornice.

Flat Arch: A straight horizontal arch consisting of reciprocally supportive wedge shaped bricks. An arch with small rise to span ratio.

Footing: The supporting base or groundwork of a structure, as for a wall.

Foundation: The base of a building that rests directly on earth and carries the load of the structure above.

G

Grade: The pitch or slope of the soil/ground adjacent to a building. Ground level.

H

Head Joint: The vertical joints between bricks in a masonry wall.

Header: Framing members over windows, doors, or other openings. A beam placed perpendicular to joists and to which joists are attached in framing around an opening.

Header Course: A series of brick laid flat with their width at the face of the wall, or parallel to the face of the wall.

I

Integrity is the authenticity of a property's historic identity, evidenced by the survival of physical characteristics that existed during the property's historic period or period of significance.

J

Joist: One of the horizontal supporting members that run from wall to wall, wall to beam, or beam to beam to support a ceiling, roof, or floor.

L

Lintel A horizontal structural member, such as a steel beam or stone, that spans an opening, as between the uprights of a door or window or between two columns or piers

Live loads, or imposed loads, are temporary, of short duration, or moving.

Load-bearing wall (or bearing wall): A wall that bears a load resting upon it by conducting its weight to a foundation structure.

M

Maintain: To keep in an existing state of preservation or repair.

Massing: The three-dimensional form of a building.

Material Change: A change that will affect either the exterior architectural or environmental features of an historic property or any structure, site, or work of art within an historic district.

N

Non-load-bearing: Walls carry only their own weight and support only themselves.

P

Parapet: A low, protective wall along the edge of a roof, bridge, or balcony

Pier: A reinforcing structure that projects from a wall; a buttress

Pilaster: A pier or pillar attached to a wall, often with a capital and base, that projects slightly from the wall, to provide ornamentation.

Pitch: The slope of a roof.

Preservation is defined as the act or process of applying measures necessary to sustain the existing form, integrity, and materials of an historic property. Work, including preliminary measures to protect and stabilize the property, generally focuses upon the ongoing maintenance and repair of historic materials and features rather than extensive replacement and new construction.

R

Rafters: A **rafter** is one of a series of sloped structural members (beams) that extend from the ridge to the wall-plate or eave, and that are designed to support the roof deck and its associated loads

Recommended: Suggested, but not mandatory actions summarized in the report.

Rehabilitation is defined as the act or process of making possible a compatible use for a property through repair, alterations, and additions while preserving those portions or features which convey its historical, cultural, or architectural values.

Reinforcing: Steel reinforcement that embedded in the mortar joints of brick masonry.

Renovation is defined as the act or process of eliminating the qualities that define the historic character of a building, if they remain extant, and upgrading the property, or portions thereof, to adapt it to contemporary needs.

Restoration is defined as the act or process of accurately depicting the form, features, and character of a property as it appeared at a particular period of time by means of the removal of features from other periods in its history and reconstruction of missing features from the restoration period.

Rivet: A permanent mechanical fastener.

Roof: The covering on the uppermost part of a building. A roof protects the building and its contents from the effects of weather

S

Scale: Proportional elements that demonstrate the size, materials, and style of buildings.

Secretary of the Interior's Standards: A series of National concepts about maintaining, repairing, and replacing historic materials, as well as designing new additions or making alterations. The Guidelines offer general design and technical recommendations to assist in applying the Standards to a specific property. Together, they provide a framework and guidance for decision-making about work or changes to a historic property.

Sill: The bottom horizontal member of a wall or building to which vertical members are attached.

Significant: Having particularly important associations within the contexts of architecture, history, and culture. The importance of an element, building or a site, owing to its involvement with a significant event, person, or time period, or as an example of an architectural style. Also historically significant.

Slab on Grade: A type of foundation with a concrete floor which is placed directly on the soil.

Soffit: The horizontal underside of an eave or cornice.

Sounding: A probe or test of a masonry wall by tapping with tools to detect voids and deteriorated materials.

Stoop: The steps and landing which lead to an exterior door.

Structural Slab: A shallow, reinforced-concrete structural member that is very wide compared with depth. Spanning between beams, girders, or columns, slabs are used for floors and roofs.

T

Top Chord - An inclined or horizontal member that establishes the upper edge of a truss, Usually carrying combined compression and bending stresses.

Truss: An engineered pre-built component, designed to carry its own weight and added superimposed design loads, that most often functions as a structural support member. A truss employs one or more triangles in its construction.

V

Vernacular: Most simply, vernacular is non-architect design and of local origin.

W

Wall: A **wall** is a vertical structure, usually solid, that defines and sometimes protects an area. Most commonly, a wall delineates a building and supports its superstructure.

Web: The term often given to the shorter members that join the top and bottom chords of a roof or floor Truss, which form triangular patterns in that Truss

Wythe: A continuous vertical section of masonry one unit in thickness.