

# MARVIN HISTORIC

WINDOWS AND DOORS

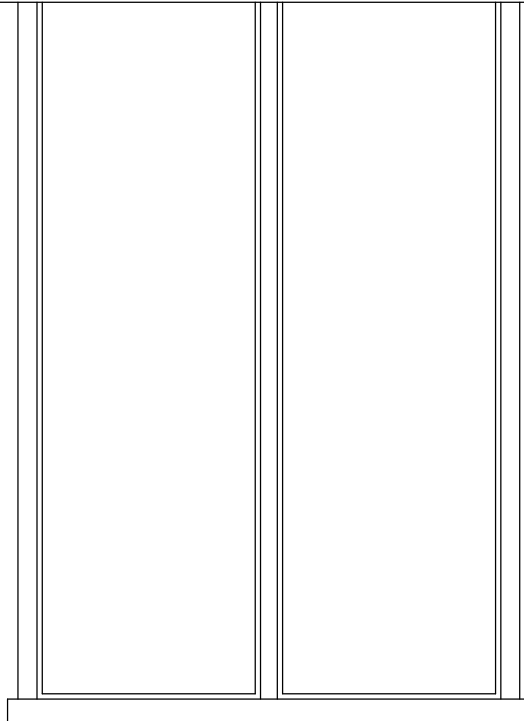

**MARVIN**  
COMMERCIAL SOLUTIONS



MARVIN HISTORIC

---

## OUR HISTORY MAKES US UNIQUELY QUALIFIED TO HANDLE YOUR PIECE OF HISTORY.

For four generations, Marvin® has built a reputation for doing the tough window replacement projects that no one else can do. We've been solving historic rehabilitation challenges longer than anyone else, and we know the ins and outs - collaborating early on with architects, facilities managers and general contractors, reviewing products and options, navigating the National Parks Service guidelines, discussing window specifications with local historic commissions, and attending field testing. We offer the best project-based solutions and do what it takes to achieve excellent performance and historical accuracy.

**Building:** St. Mary's Church | Potsdam, NY

**Architect:** Jerry MacNeil Architects Ltd. **Contractor:** J.T. Erectors

**Units & Applications:** Fifteen custom Mahogany exterior and interior Gothic Revival wood window units, 3 at 70" x 216 1/2", 11 at 58" x 195", one at 171" x 276 1/2" integrating a 14 ft. diameter Rose Window. Pieces of Honduran mahogany were assembled in six layers with staggered finger jointing. Digital measurements using various technologies enabled accurate sizing to accommodate fixed masonry and glass dimensions. Designs downloaded directly to Marvin's CNC equipment for a paperless project.



## MARVIN HISTORIC EXPERTISE

---

# "BEEN THERE, DONE THAT," IS SOMETHING WE'VE BEEN SAYING FOR OVER 100 YEARS.

With Marvin® products on over 500 college and university campuses and countless government, religious and Main Street buildings, Marvin is a proven leader in replacement windows for existing commercial buildings. At every level and every step of the way, Marvin surrounds your project with an unmatched level of expertise. You'll work with one of Marvin's Architectural Project Managers, who bring a deep understanding of building science to every project and provide invaluable consultation services from initial budget estimates to completion. On the product and fabrication side, Marvin Technical Services, along with the Architectural Department, can engineer solutions to address structural reinforcement, profile replication, panning, mulls or other manufacturing or construction challenges.

**Building:** Savannah Law School | Savannah, GA

**Architect:** Lynch Associates

**Units & Applications:** The federal tax credit restoration and rehabilitation project replaced windows in 100 openings with Marvin Wood Ultimate Double Hung and Wood Ultimate Double Hung Magnum units, single glazed with authentic divided lites and 7/8" muntins.

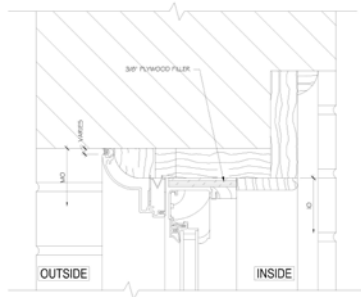
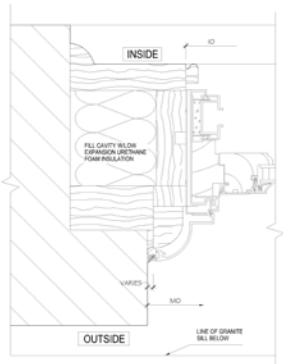

## MARVIN HISTORIC SOLUTIONS

---

# WHEN IT COMES TO MEETING STRICT HISTORICAL STANDARDS, MARVIN SETS THE STANDARD.

No matter the scale or scope of the historic replacement project, Marvin® does all the little things that make the biggest difference. From exact sizing to the ability to replicate intricate historic profiles, Marvin's attention to detail is unsurpassed. Marvin's vast array of products and custom solutions are painstakingly engineered to meet the most exacting historical specifications, while delivering state-of-the-art performance.

**Building:** 311 Summer Street | Boston, MA

**Architect:** ADD Inc. Architectural Firm   **Contractor:** Shawmut Design and Construction

**Units & Applications:** Plans for aluminum full-frame replacement windows with a pre-fit panning system resulted in reduced glazing dimensions, which were unacceptable to local historic preservation authorities. The Marvin solution installed panning over the existing frames and used Marvin's Tilt Pac® for sash replacement. Rapid prototyping was used to develop extruded aluminum panning that precisely replicated the existing profile. This allowed for installation of a sash that had the same amount of glass as previous windows. An aluminum extrusion was made to fill the arched masonry opening on the exterior. The same extrusion was installed as the vertical mullion cover. Panning was attached to the frame and followed the edge of the milled infill panel on the exterior, squaring off with the window on the interior.

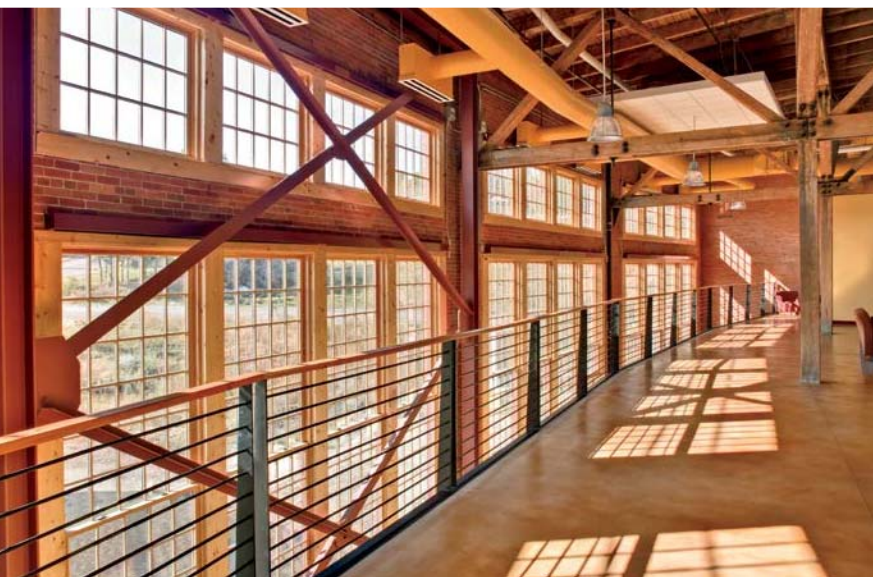

**Building:** Evanston Roundhouse | Evanston, WY

**Architect:** Myers-Anderson

**Contractor:** Hogan and Associates

**Units & Applications:** The original criteria required re-use of existing operating windows with wood trim for rough openings over twenty feet wide. Budget and schedule considerations suggested that a different solution was needed. Window manufacturers submitted proposals and Marvin® won the bid based on detailed rapid prototypes. Restoration costs were estimated to be 2-3 times more expensive than custom-made aluminum-clad Marvin units with custom clad casing and subsills. Clad Magnum Double Hungs with 2" checkrail, enhanced by  $\frac{7}{8}$ " simulated divided lites with spacer bars were used, along with casement wood sashes and picture windows.





## MARVIN SIGNATURE

THE MARK OF AN ORIGINAL

---

### **WE MAKE THE IMPOSSIBLE, POSSIBLE.**

For historic replacement projects that require a higher level of craftsmanship, attention to detail and expertise, Marvin® Signature Services is called upon to deliver fully custom, one-of-a-kind solutions to the most challenging architectural problems. From custom Direct Glaze Windows to location-specific replications like Nantucket and Boston sashes, the highly specialized craftspeople of Marvin Signature Services are capable of engineering windows that are every bit as unique and beautiful as the originals that inspired them. If you can dream it, Marvin Signature Services can build it.

Learn more at:

[MARVINWINDOWS.COM/SIGNATURE](https://marvinwindows.com/signature)

# MARVIN HISTORIC OPTIONS

## HISTORIC WINDOWS BUILT WITH A CRITICAL EYE FOR HISTORIC DETAIL.

### — HISTORIC DETAILS —



#### INTERIOR & EXTERIOR SASH LUG

Replication sometimes requires exterior or interior lugs. Exterior sash lugs are applied by 'slide on' attachment method, while interior sash lugs are available as part of the stile or can be clip on. Factory applied, or field application kits are available.



#### CHAIN AND PULLEY

A chain and pulley balance system can contribute to the authentic appearance of replacement windows. Available in a variety of styles and finishes, the hardware and counterbalanced sash provide smooth operation, even for very large hung windows.



#### DIVIDED LITES

Marvin® offers a variety of ways to replicate historic window pane patterns. Patterns can feature an array of muntin widths, unique muntin profiles, rectangular or radius cuts and more. Custom divided lites available.



#### GLASS AND GLAZING

Marvin offers a broad array of decorative and specialty glass options, including Restoration glass or Circa glass to meet National Park Service guidelines. Additional glazing options are available to meet requirements for sound abatement, Sea Turtle Conservation Codes and California fire zone specifications.

# — CASING & SUBSILLS —

Marvin® offers hundreds of clad and wood casing options and has the capability to create custom casings to match existing profiles. Our clad casings are made of extruded aluminum, which features an extremely durable factory applied finish that resists chalking, fading, pitting, corrosion and marring, and is backed by a 20-year warranty against chalk and fade. Meets AAMA 2605.

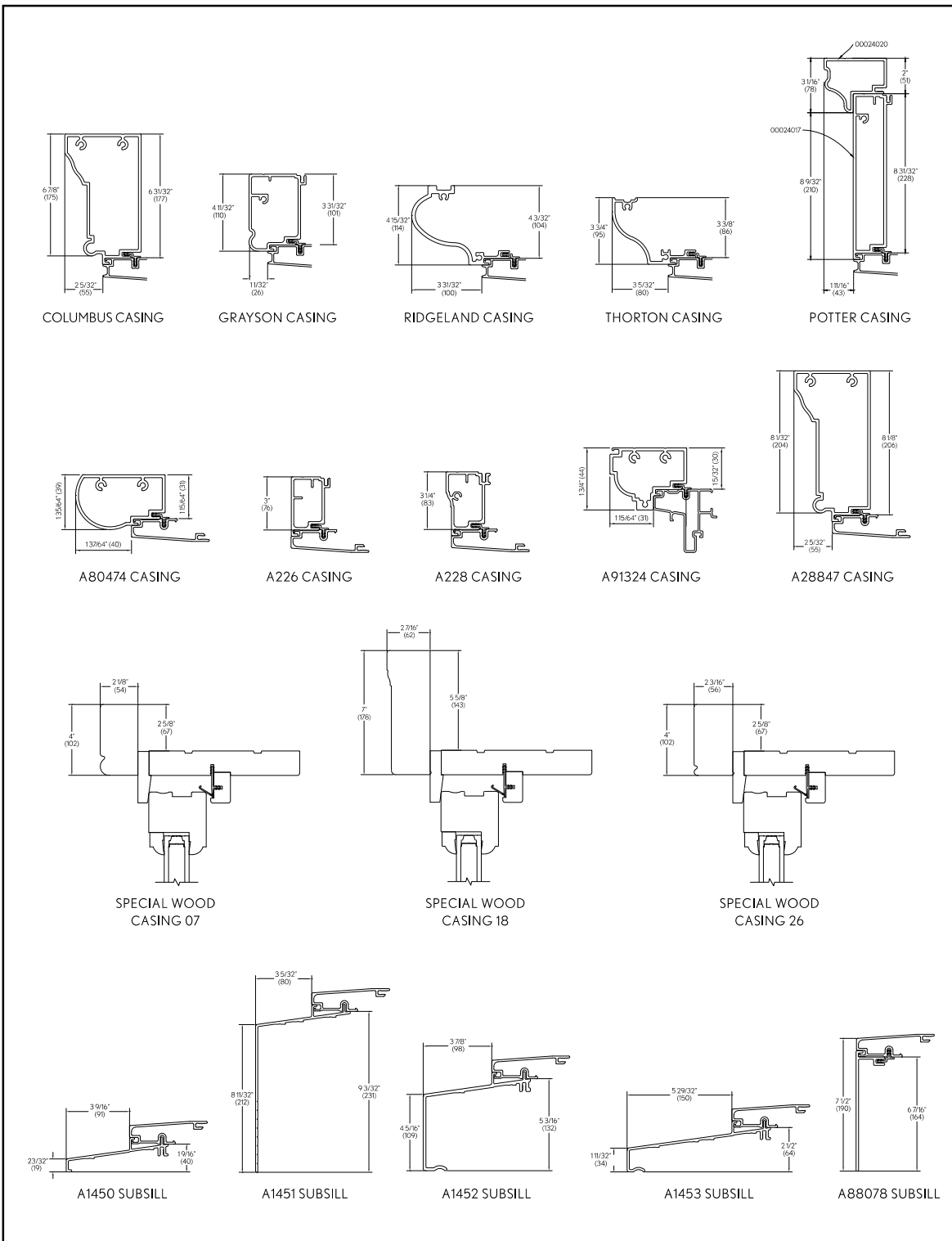

— CLAD COLORS —

Marvin's low-maintenance, clad-wood products feature an extruded aluminum exterior finish in commercial-grade paint that meets AAMA 2605 certification for superior resistance to fading and chalking. Marvin's palette of nineteen durable colors includes a spectrum of rich colors and three fresh, pearlescent finishes.

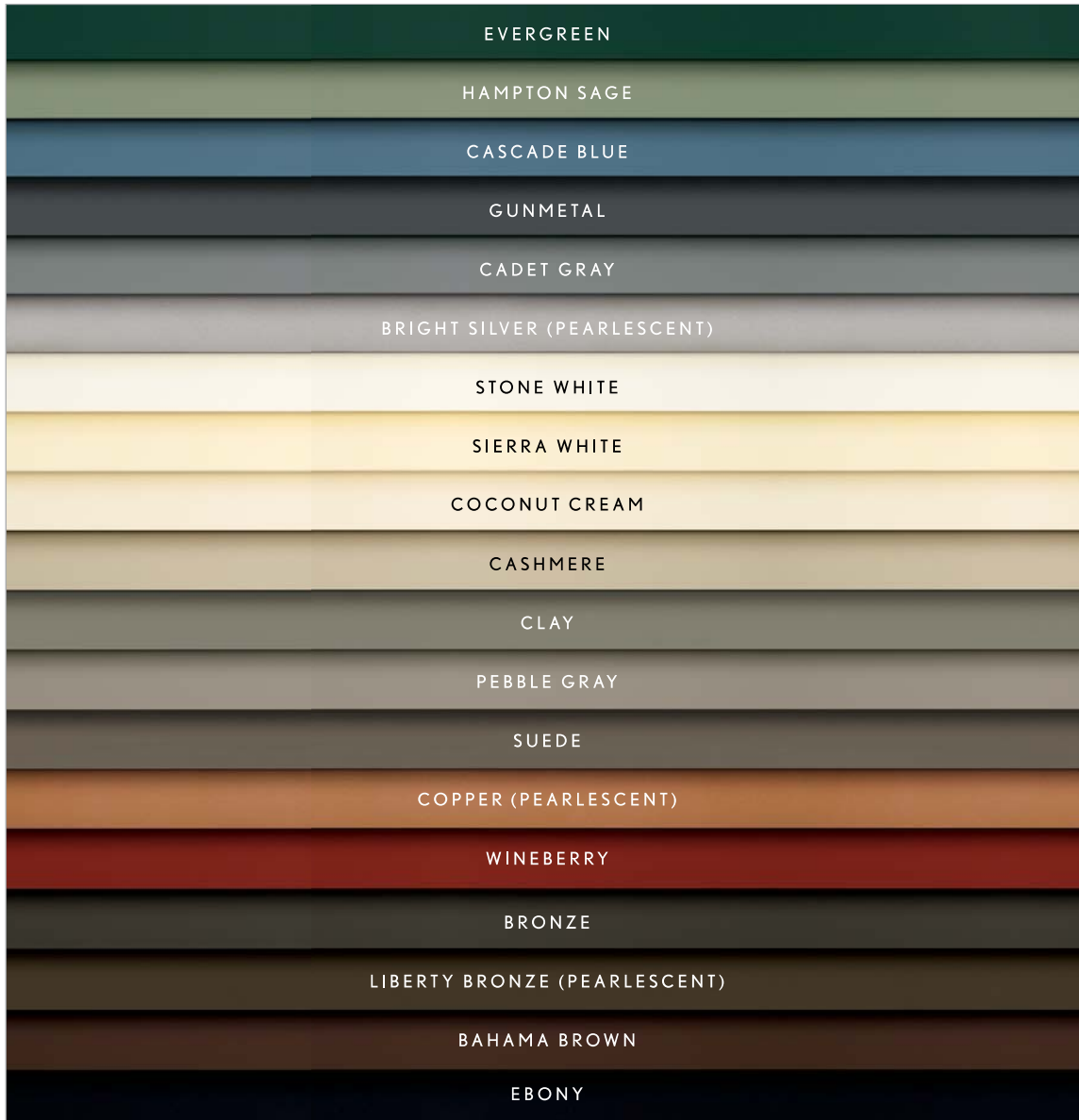

**Custom Colors:** For projects that require new replica windows to match the existing originals, Marvin® can create a custom color. Like our standard exterior finish colors, custom colors are backed by a 20-year warranty.\*

**ANY COLOR  
YOU WANT**

\*Some colors may not qualify for the 20-year warranty. Contact your Marvin representative for details.

## — EXTERIOR WOOD SPECIES —

Marvin® offers three high-quality exterior wood species, including Pine, Vertical Grain Douglas Fir and Mahogany. All species are available FSC™/SFI® certified. Factory-primed pine available.



## — INTERIOR WOOD SPECIES —

Marvin offers six high-quality interior wood species, including Pine, Cherry, Douglas Fir, Mahogany, Vertical Grain Douglas Fir and White Oak. Specialty species include Maple, Black Walnut and Western Red Cedar. All species are available FSC/SFI certified.



## — INTERIOR FINISH OPTIONS —

Before a factory-finished window is assembled, every wood component is conditioned, sanded and baked to ensure complete coverage. All finishes are water-based and have no Volatile Hazardous Air Pollutants (VHAP). State approved procedures are used to contain Volatile Organic Compounds. All meet WDMA TM 14-09 standards.



CLEAR COAT



STAINED



PAINTED INTERIOR  
FINISH - WHITE



FACTORY-APPLIED  
PRIMED

## NEXT GENERATION ULTIMATE DOUBLE HUNG



### DESIGN

- Fits large openings up to 5' x 10'
- Balance system provides block and tackle balance or hybrid spiral balance
  - Note:** Balance system is determined by sash weight
- Multi-point locking system provides locking, unlocking, venting and tilting of the sash members
- Options for historic packages include exterior sash lugs, and combination storm sash and screens
- Available prepped for field-applied stool and apron
- Custodial locking hardware available
- 1<sup>15</sup>/<sub>16</sub>" checkrail for traditional appearance
- Frame bevel: 14 degree
- All wood jambs and full wood interior
- Ultimate Double Hung Next Generation products include single hung, double hung, picture and transom windows

### INSTALLATION

- Through jamb installation
- Optional flexible metal nailing fin

### PERFORMANCE

- Meets U-factor/SHGC of 0.30/0.30 with one-lite Low E2 with argon insulating glass
- Optional U-factor/SHGC as low as 0.20/0.17 or 0.21/0.41 with optional coatings and gas fills on Tripane glass, without combination
- Depending on glass options, the STC range is 27 - 41; the OITC range is 23-35

— DESIGN AND PERFORMANCE REQUIREMENTS —

PRODUCT	AIR TEST TOPSF	WATER TESTED TOPSF	STRUCTURAL TESTED TOPSF	CERTIFICATION RATING	OVERALL WIDTH	OVERALL HEIGHT
Clad Ultimate Double Hung Next Generation	1.57	7.5	75	LC-PG50	45 1/4	87 1/2
Clad Ultimate Double Hung Next Generation	1.57	7.5	75	LC-PG50	45 1/4	95 1/2
Clad Ultimate Double Hung Next Generation	1.57	7.5	75	LC-PG50	49 1/4	107 1/2
Clad Ultimate Double Hung Next Generation, High Performance	1.57	9.75	97.5	LC-PG65	49 1/4	107 1/2
Clad Ultimate Double Hung Next Generation	1.57	6	60	LC-PG35	59 1/4	119 1/2
Clad Ultimate Double Hung Next Generation Picture	1.57	7.5	75	CW-PG50	67 1/4	69 1/2
Clad Ultimate Double Hung Next Generation Picture	1.57	7.5	75	CW-PG50	61 1/4	103 1/2
Clad Ultimate Double Hung Next Generation Picture, High Performance	1.57	9.75	97.5	CW-PG65	61 1/4	103 1/2
Clad Ultimate Double Hung Next Generation Transom	1.57	7.5	75	LC-PG50	45 1/4	27 11/16
Clad Ultimate Double Hung Next Generation Transom	1.57	7.5	75	LC-PG50	73 1/4	27 11/16
Clad Ultimate Double Hung Next Generation Transom, High Performance	1.57	9.75	97.5	LC-PG65	73 1/4	27 11/16

— CERTIFIED MULLS —

ASSEMBLY	TYPE	MAX MULLION SPAN	MAX TRIBUTARY	MULL DESIGN PRESSURE
1 High, 2 or more units wide	CUDH NG to CUDH NG only	71 1/2" (1816 mm)	45 1/4" (1149) wide	DP50
1 Wide, 2 or more units high	CUDHT NG over CUDHP NG only	69 1/4" (1759 mm)	53 19/32" (1361) wide	DP50
Multiple Wide x High w/ 1" LVL	LVL must be in vertical mull	75" (1922 mm)	45 11/16" (1161) wide	DP50
Multiple Wide x Multiple High w/ 3/8" (10 mm) MRF	CUDHT NG over CUDH NG only	83 3/16" (2113mm)	45 3/8" (1153) wide	DP65

**Note:** the entire assembly will have the lowest design pressure of any unit or mull in the assembly.

## ULTIMATE INSERT DOUBLE HUNG



### DESIGN

- The Ultimate Insert Double Hung is designed to meet historic design daylight criteria
- Frame thickness:  $2\frac{1}{32}$ " (17mm) head jamb,  $1\frac{5}{16}$ " (33mm) composite side jamb\*
- Frame depth:  $3\frac{1}{4}$ " (83mm) to accommodate standard double hung pocket depths\*
- Frame bevel: 8 degree or 14 degree\*
- Balance system: Coil spring block and tackle with nylon cord and fiber filled nylon clutch
- Field installed half screen or full screen; half screen covers bottom sash opening
- Optional Magnum Screen (Extruded aluminum surround with charcoal hi-transparency fiberglass mesh)

### INSTALLATION

- Through jamb installation

### PERFORMANCE

- Meets U-factor/SHGC of 0.30/0.30 with one-lite Low E2 with argon insulating glass
- Optional tripane glass, coatings, and gas fills available for U-factor/SHGC as low as 0.21/0.18 or 0.22/0.41

\*Clad unit specifications listed. Ask your Marvin® representative for wood unit specifications.



— DESIGN AND PERFORMANCE REQUIREMENTS —

PRODUCT	AIR TEST TOPSF	WATER TESTED TOPSF	STRUCTURAL TESTED TOPSF	CERTIFICATION RATING	OVERALL WIDTH	OVERALL HEIGHT
Aluminum Clad Insert Double Hung	1.57	4.5	45	LC-PG30-H	45	77 3/8
Aluminum Clad Insert Double Hung Picture	1.57	6	60	CW-PG40-FW	68	77 5/8
Aluminum Clad Insert Double Hung Transom	1.57	6	60	LC-PG40-TR	75 5/8	28
Wood Insert Double Hung	1.57	6	60	LC-PG30-H	35 3/8	81
Wood Insert Double Hung	1.57	6	60	LC-PG30-H	45 3/8	61
Wood Insert Double Hung	1.57	6	45	LC-PG30-H	45 3/8	81
Wood Insert Double Hung 1 5/8" Picture	1.57	6	60	LC-PG40-FW	61 3/8	57
Wood Insert Double Hung 2" Picture	1.57	6	60	LC-PG40-FW	69 3/8	81
Wood Insert Double Hung Transom	1.57	6	60	LC-PG40-TR	73 3/8	26 1/2



BEFORE



AFTER

The Marvin® Ultimate Insert Double Hung is a frame-in-frame application, designed to seamlessly fit an opening when full-frame replacement is not the optimal solution.

## ULTIMATE MAGNUM DOUBLE HUNG



### DESIGN

- Fits oversized openings up to 5' x 10'
- Rectangular, polygon and round top shapes available
- Available as single hung, double hung, triple hung, picture and transom windows
- Options for historic packages include energy panels and ogee lugs
- Adjustable constant force spiral balance system meets AAMA 902-99 Class 5 specifications
- Fiber filled nylon clutch
- Designed to balance sash from 10 lbs to 130 lbs
- Available prepped for field-applied stool and apron
- Fixed sash in wood units available in 1<sup>5</sup>/<sub>8</sub>" and 2"
- Custodial locking hardware available

### INSTALLATION

- Through jamb installation
- Optional flexible metal nailing fin

### PERFORMANCE

- Meets U-factor/SHGC of 0.30/0.30 with one-lite Low E2 with argon insulating glass
- Optional U-factor/SHGC as low as 0.20/0.17 or 0.22/0.40 with optional coatings and gas fills on Tripane glass, without combination
- Depending on glass options, the STC range for clad units is 27 - 34, OITC range is 22-29. Wood unit STC range is 28-34, OITC range is 24-29

— DESIGN AND PERFORMANCE REQUIREMENTS —

PRODUCT	AIR TEST TOPSF	WATER TESTED TOPSF	STRUCTURAL TESTED TOPSF	CERTIFICATION RATING	OVERALL WIDTH	OVERALL HEIGHT
Aluminum Clad Ultimate Double Hung Magnum	1.57	5.25	52.5	LC-PG35-H	59 3/8	120 3/8
Aluminum Clad Ultimate Double Hung Magnum High Performance	1.57	7.52	75.24	LC-PG50-H	59 3/8	120 3/8
Aluminum Clad Ultimate Double Hung Magnum	1.57	6.06	60.15	CW-PG40-H	55 3/8	92 3/8
Aluminum Clad Ultimate Double Hung Magnum	1.57	7.5	75	CW-PG50-H	53 3/8	104 3/8
Aluminum Clad Ultimate Double Hung Magnum Picture	1.57	10.5	75	CW-PG50-FW	61 3/8	104 3/8
Aluminum Clad Ultimate Double Hung Magnum Transom	1.57	8.25	75	LC-PG50-TR	73 3/8	27 3/8



### STORM & SCREEN COMBINATIONS

A combination unit is composed of two glass panels and one screen panel. Panels can be arranged in many ways: glass above screen, screen above glass or glass above glass. One of the glass panels slides behind the other for self storage when the screen is in use. Panels can be easily removed from the interior for cleaning. Available with a wood or aluminum clad surround.



### TWO-LITE WOOD STORM SASH OR SCREEN

A wood frame containing non-removable glass. The storm sash can be removed during the summer and replaced with a wood framed screen. Available only for wood windows.

## SIMULATED DOUBLE HUNG HOPPER



### DESIGN

- Double hung appearance with the lower sash designed as a hopper for ease of operation
- A good solution for hard-to-reach areas, like over a radiator or built-in bookshelves
- Multi-lock system and hopper style operation for limited accessibility
- High energy efficiency; high-performance seal controls air infiltration
- Upward-directed airflow provides comfortable ventilation
- Available with multiple handle and finish options
- Minimum RO width: 18 <sup>3</sup>/<sub>8</sub>" Minimum RO height: 40"

### INSTALLATION

- Adjustable hinges
- Through jamb installation
- Factory applied jamb extensions available
- Factory-installed half screen

### PERFORMANCE

- Meets U-factor/SHGC of 0.31/0.30 with one-lite Low E2 with argon insulating glass
- Optional U-factor/SHGC as low as 0.20/0.17 or 0.21/0.44 with optional coatings and gas fills on Tripane glass
- Depending on glass options, the STC range is 32-37; the OITC range is 28-34

— DESIGN AND PERFORMANCE REQUIREMENTS —

PRODUCT	AIR INFILTRATION	WATER TESTED TO PSF	STRUCTURAL TESTED TO PSF	CERTIFICATION RATING	OVERALL WIDTH	OVERALL HEIGHT
Clad Simulated Double Hung Hopper	0.05 L/s/m <sup>2</sup> (0.01 cfm/ft <sup>2</sup> )	220 Pa (4.60 psf)	1440 Pa (±30.09 psf)	CW-PG30-AP	59 3/8"	128 5/8"



Locking points in the window's multi-lock system are located at the checkrail and at the jambs.



The unobtrusive screen tucks neatly under the checkrail.



Designed for replacement or new construction, this window can provide a perfect solution in university, government, and other institutional applications.

## NEXT GENERATION ULTIMATE DOUBLE HUNG ROUND TOP



### DESIGN

- Fits openings up to 5' x 10'
- Available in various radius shapes including eyebrow, elliptical, half circle, and custom angles
- Available in variations of standard double hung rectangular window on the interior with arched exterior casing
- Matches other Next Generation product profiles
- Arched window unit can include transom
- Balance system provides block and tackle balance or hybrid spiral balance
- Note:** Balance system is determined by sash weight
- Custodial locking hardware available
- Wood jambs minimize visibility of jamb carrier system

### INSTALLATION

- Through jamb installation
- Optional flexible metal or vinyl nailing fin
- Installation hardware included

### THERMAL PERFORMANCE

- Meets U-factor/SHGC of 0.30/0.30 with one-lite Low E2 with argon insulating glass
- Optional U-factor/SHGC as low as 0.20/0.17 or 0.22/0.41 with optional coatings and gas fills on Tripane glass, without combination

— DESIGN AND PERFORMANCE REQUIREMENTS —

PRODUCT	AIR TEST TOPSF	WATER TESTED TOPSF	STRUCTURAL TESTED TOPSF	CERTIFICATION RATING	OVERALL WIDTH	OVERALL HEIGHT
Clad Ultimate Double Hung Next Generation Round Top	157	7.5	75	LC-PG50	45 1/4	87 1/2
Clad Ultimate Double Hung Next Generation Round Top	157	7.5	75	LC-PG50	49 1/4	107 1/2
Clad Ultimate Double Hung Next Generation Round Top	157	7.5	75	LC-PG50	49 1/4	107 1/2
Clad Ultimate Double Hung Next Generation Round Top	157	5.43	52.5	LC-PG35	59 1/4	119 1/2
Clad Ultimate Double Hung Next Generation Round Top	157	5.43	52.5	LC-PG35	59 1/4	119 1/2
Clad Ultimate Double Hung Next Generation Round Top Picture / Transom	157	7.5	75	CW-PG50	74 1/4	103 1/2

— ROUND TOP RADIUS SHAPES —



EYEBROW RADIUS  
OPERATING  
DOUBLE HUNG



HALF CIRCLE  
TRANSOM



EYEBROW TRANSOM



HALF CIRCLE RADIUS  
OPERATING  
DOUBLE HUNG



HALF EYEBROW  
OPERATING  
SINGLE HUNG





— ROUND TOP VARIATIONS —

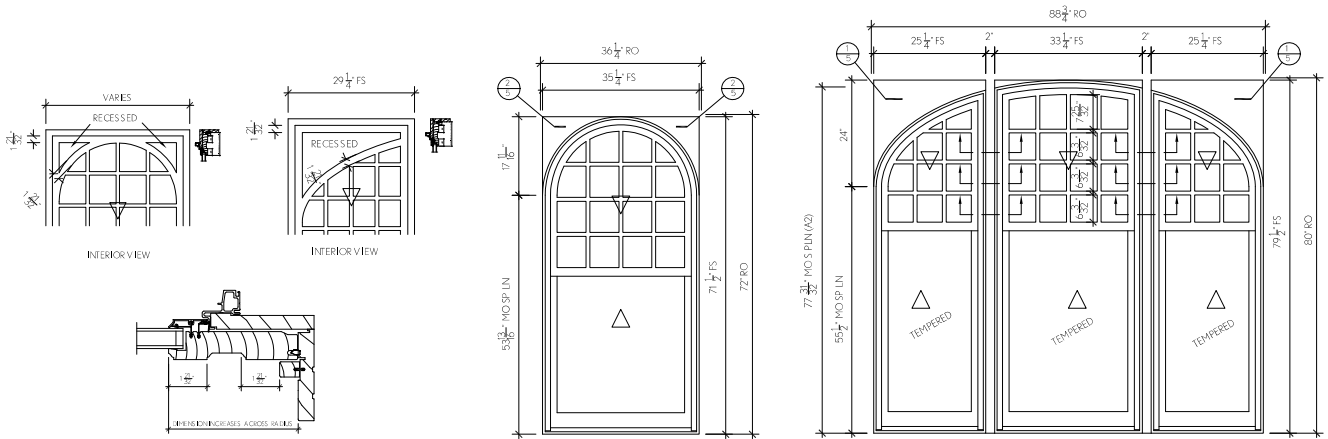

Some projects call for window units or assemblies designed with graceful radius curves on the exterior and rectangular, operating hung windows on the interior.

Marvin® has a range of radius variations for design flexibility.

— ROUND TOP WITH RECTANGULAR FRAMING —

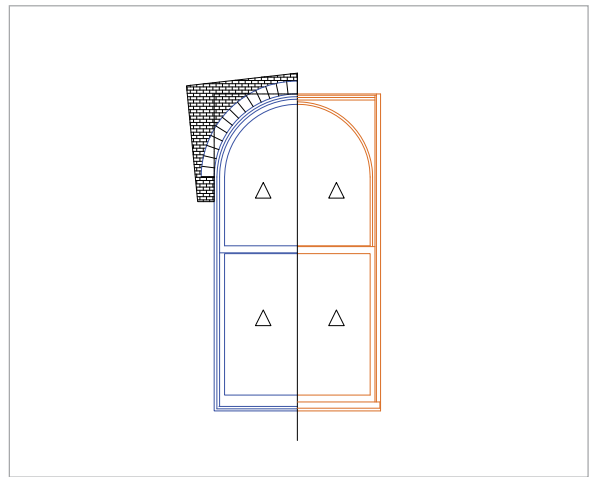

EXTERIOR INTERIOR

**Building:** Central Union Mission | Washington, D.C.

**Architect:** Cox Graae + Spack Architects **Contractor:** Forrester Construction

**Units & Applications:** Marvin Clad Ultimate Double Hung Windows and Round Top Transoms were used with Thorton casings to match original window profiles. Custom flashing solutions addressed waterproofing issues in the existing masonry.



## MARVIN HISTORIC WINDOWS

# IT'S OUR JOB TO MAKE HISTORY REPEAT ITSELF.

While a majority of projects require variations of traditional double hung windows, it's possible to achieve meticulously detailed historic looks with other products. From casement and awning to direct glaze and polygon shapes, Marvin® offers a complete family of windows that can be customized to match the specialized requirements of certain historic projects.



ULTIMATE  
CASEMENT WINDOW



SPECIALTY SHAPES



DIRECT GLAZE

**Building:** Druid Hill Conservatory | Baltimore, MD

**Architect:** Kann Associates    **Contractor:** Graziano Construction and Development Company, Inc.

**Units & Applications:** Two new greenhouse structures were constructed, sited symmetrically to a Baltimore landmark called the Palm House, built in 1888. Designers of the new buildings sought detailing in the original Palm House architectural drawings in order to match them, but found none. Marvin developed shop drawings and worked with the designer and contractor to address anchorage and structural engineering, custom flashing and panning, thermal and water performance. Clad awnings, casements, polygon units, clad variation #5 mill plates to replicate round tops on the original building, tempered glass with simulated divided lite, custom clad color, custom casing and sill adapter were used.

## CASE STUDY #1: MUNICIPAL BUILDING RENOVATION

**Challenge** | Exactly replicate in extruded aluminum the original wood mulls with decorative appliqué.

**Marvin® Technical Services Solution** | To replicate this ornate appliqué, a mull from the original windows was scanned with a 3D scanner. The decorative wood mull in the photo is the only known original appliqué that exists. The scan was used to create an exact replica of the mulls and plinths. Before the appliqué was milled, it was printed in 3D and sent over to the historic review board. A mock-up of the proposed window assemblies was installed on site for approval before the order for the window assemblies was submitted. A complex project, the 145 openings required both standard and custom window products. Besides the milled appliqués, the project required six new dies and 5 sizes of milled plinths.

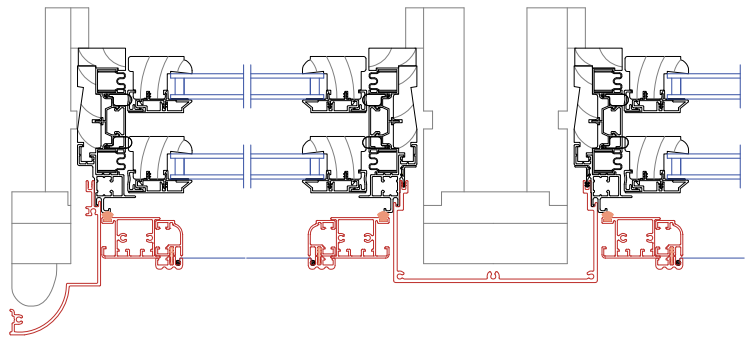

**SIDE JAMB VERTICAL MULL**

**Note:** Detail shows the relationship of the daylight opening to the brick. Special sized stile and rail components might be required to match both the glass DLO and the brick to DLO dimensions.

## CASE STUDY #3: OLD MAIN WINDOW REHABILITATION

**Challenge** | Meet the strict requirements of the local Historic Preservation Commission.

**Marvin Technical Services Solution** | The Marvin Architectural Project Manager supported Macalester College by providing detailed drawings, attending HPC meetings with facilities personnel, and answering HPC questions about the proposed window replacement project. When the Commission determined that the transom bottom rail was too tall, Marvin adjusted the design and the plan was approved. The particular challenge of this project was that custom casings for the replacement windows needed to match existing profiles to the exterior, and to marry up with interior jamb extensions and trim, which would not be rebuilt to accommodate new window units. For some openings, the Architectural Project Manager designed custom jamb extensions, which were milled and applied in the factory.





**CASE STUDY #2: STATE UNIVERSITY WINDOW REPLACEMENT**

**Challenge** | Replace windows in 84 openings to match original profiles.

**Marvin® Technical Services Solution** | The Marvin Architectural Project Manager mapped out the existing window conditions, measuring every component and how the window related to the brick opening. He then developed a CAD drawing based on existing conditions research, and overlaid proposed product solutions using Marvin Ultimate Insert Double Hung Windows. Custom casings and mull covers were required to match the original profiles. Marvin created rapid prototypes to demonstrate how window components could be replicated in extruded aluminum to exactly match the original wood profiles. Approval based on the review of rapid prototyping was written into the specs. This project filled 84 window openings with 1-wide x 2-high and 2-wide x 2-high assemblies.



REVISED PROPOSED  
DOUBLE HUNG  
HORIZONTAL MULL

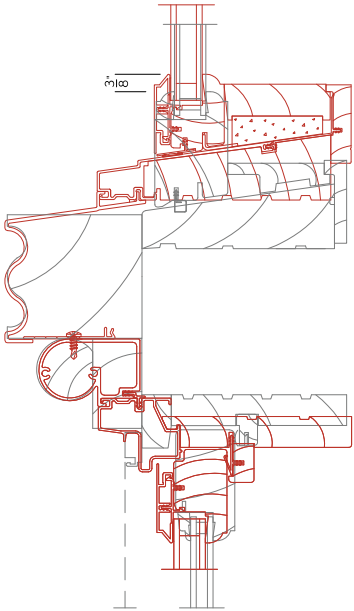

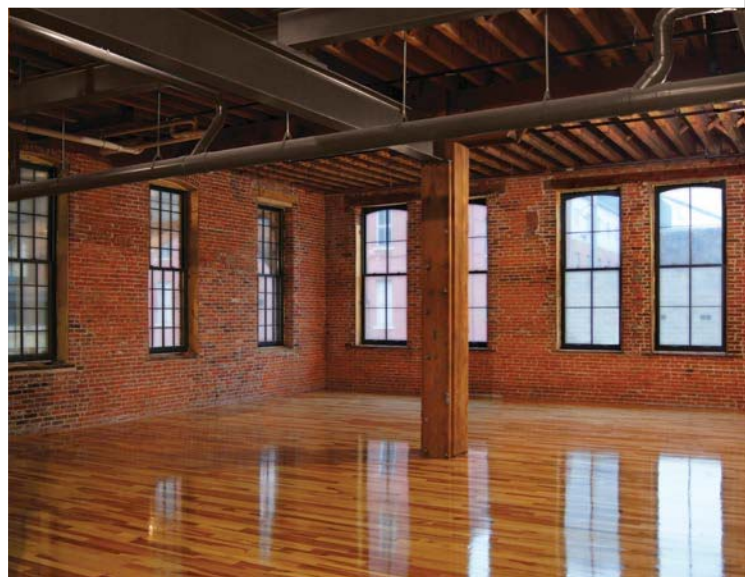

**Building** | CARADCO Building, Dubuque, Iowa, built 1888

**Developer** | Gronen Properties / Gronen Renovations

**Units & Applications** | The Caradco building was honored by winning the National Trust for Historic Preservation Tony Goldman Award in 2015. This award celebrates projects that embody a bold, large-scale approach to historic preservation that catalyzes entire commercial districts. The rehabilitation required the replacement of wood windows in 300 openings. One elevation called for radius windows. Marvin® Ultimate Magnums were required in some openings. In the majority of openings, Marvin Wood Ultimate Double Hung Windows with simulated divided lites, a standard product, were used. Each opening was unique and needed to be measured separately.

MARVIN HISTORIC

---

## LET'S MAKE HISTORY.

Sometimes, we renovate more than just a building. In the case of the CARADCO building in Dubuque, Iowa, we were part of a project that helped start the rejuvenation of an entire section of town. This project is the perfect example of what we do best at Marvin: Applying four generations of expertise with state-of-the-art tools and technologies to replicate windows that seamlessly combine modern performance with rich period detail to meet the high standards of historic commissions, architects and occupants alike.

Get your next project started by contacting your local Marvin Architectural Project Manager,  
or by visiting:

[MARVINWINDOWS.COM/COMMERCIAL](https://www.marvinwindows.com/commercial)

MARVIN HISTORIC



Start your historic renovation project at [marvinwindows.com](http://marvinwindows.com)

**MARVIN**   
Windows and Doors  
Built around you.®

HANDCRAFTED  
IN AMERICA. 

©2016 Marvin Windows and Doors. All rights reserved. ®Registered trademark of Marvin Windows and Doors. Part# 19980831. May 2016.