

Bittersweet Pl. Reconstruction - 2014

Project Engineer	Jim Wolfe 266-4099
-------------------------	--------------------

Project Limits	Bittersweet Place	From Bordner Dr. to west end
Alder: Chris Schmidt		

Street	Existing	Proposed
Project Type: Full Reconstruction w/ curb installation		
Last Surfaced	1953	
Pavement Rating	4 w/ "V" cross section (icing issues)	replace asphalt pavement, crowned
Curb Rating	0, no existing curb	install new curb, modified (see reverse)
Width	Varies, 20'-23' typical	24 ft. (face to face)
Surface Type	Seal coat	Asphalt

Sidewalk
No existing sidewalk, no sidewalk proposed

Storm Sewer
Work Required: Install new storm sewer, connect into at Bordner, remove/bury surface outlet at end of street

Size	24" (outlet only)	21"
Material	Corrugated Metal	Concrete
Year	1975	2014

2013 Flow Study - small rains, water from Old Sauk, large or consecutive, water from Old Sauk & 20 acres in Owen Pk

Sanitary Sewer
Work Required: Replace pipe, laterals (most to just beyond curb), and structures

Size	6"	8"
Material	VP (Clay)	PVC
Year	1940	2014

Water Main	Existing	Proposed
Work Required: Abandon existing & install new main, reconnect services		
Size	6"	8"
Material	Cast Iron, multiple breaks	Ductile Iron
Year	1940	2014

Parking
Existing Parking Conditions: parking allowed on both sides, vehicles pull off pavement
Proposed: Parking on one side only, but may be alternate side parking in some way, still TBD

Street Lighting & Signals	Existing	Proposed
Area Street Lighting	on wood poles	no changes proposed

Trees
One planned removal at 5729 Bittersweet Pl

Cost

Total Cost	\$925,000
Adjacent Property Assessments	\$130,590
City Share	\$794,410

Assessment Policy

Concrete curb & gutter	Owner 100% / City 0%
Sanitary Sewer Lateral Replacements	Owner 25% / City 75%
Concrete Aprons & Sidewalk	Owner 50% / City 50%
Private Storm Connections	Owner 100% / City 0%

Assessments payable in one lump sum or over a period of 8 years, with 3.5% interest charged on unpaid balance

Schedule

Start Date	August 11, 2014
Project duration	Approx 2 months

Correspondence

held public info meetings on 4/17/14 and 5/1/14
Poll regarding street width/parking (28 ft. or 24 ft., unanimous support for 24')
Numerous e-mail and phone call conversations (1 included) re:
street width (some proposed 22', but emergency access concerns)
storm sewer, what outlet drains (Old Sauk & Owen Park - 20 acres)
Parking - signage, alternate side hours
Conversations w/ most indicate support of the project

see map on reverse

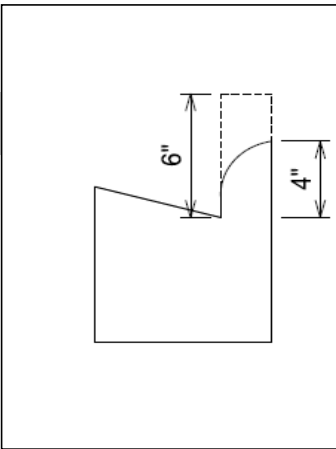
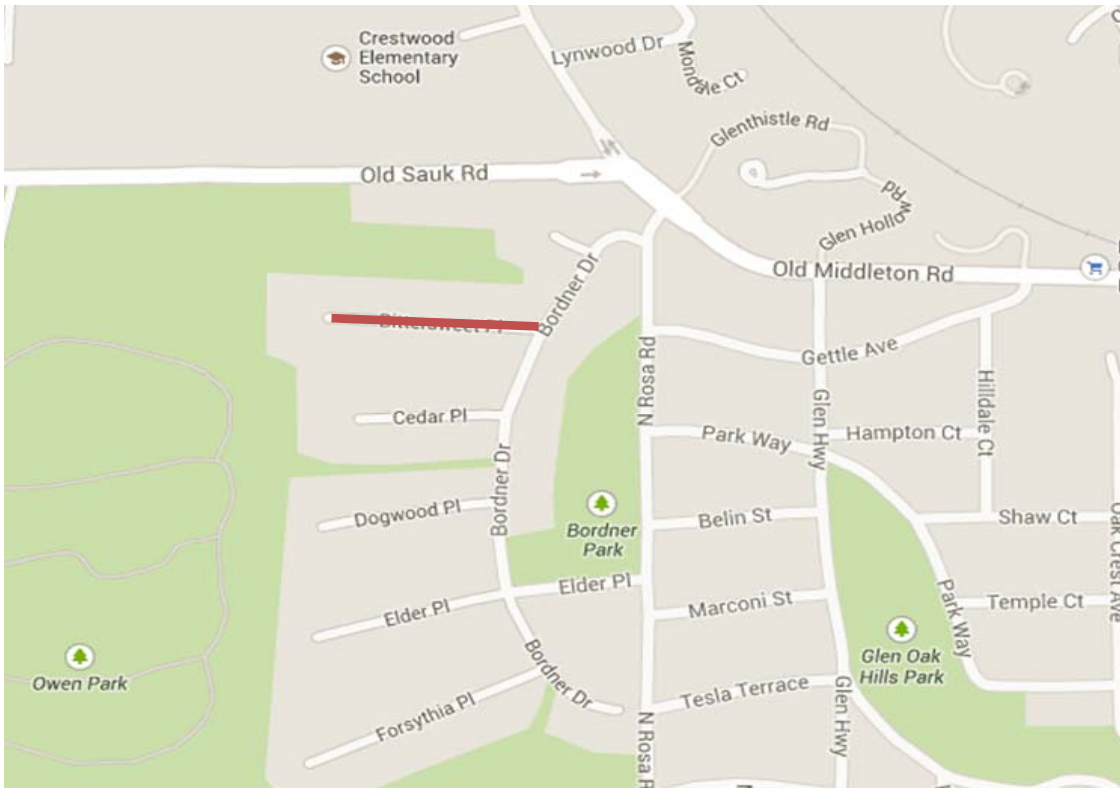

Proposed curb info:

- Smaller curb head than standard (4" vs. 6")
- More rounded than standard
- Help maintain more rural look & feel
- Still provides benefits of curb (convey water, protect pavement & terrace)