

**APPLICATION FOR  
URBAN DESIGN COMMISSION  
REVIEW AND APPROVAL**

**AGENDA ITEM # \_\_\_\_\_  
Project # \_\_\_\_\_  
Legistar # \_\_\_\_\_**

DATE SUBMITTED: <u>9-26-12</u>	<b>Action Requested</b>
UDC MEETING DATE: <u>10-13-12</u>	<input type="checkbox"/> Informational Presentation
	<input type="checkbox"/> Initial Approval and/or Recommendation
	<input checked="" type="checkbox"/> Final Approval and/or Recommendation

**PLEASE PRINT!**

**PLEASE PRINT!**

PROJECT ADDRESS: 4800 & 4950 Voges Road

ALDERMANIC DISTRICT: #16, Alder Jill Johnson (Urban Design District #1)

OWNER/DEVELOPER (Partners and/or Principals) <u>Greg Fax, General Partner, St. John Properties, Inc.</u>	ARCHITECT/DESIGNER/OR AGENT: <u>Jeremy Hartline - Haag-Muller Architects, Inc.</u>
<u>1020 James Drive, Suite G</u>	<u>101 East Grand Avenue, Suite 1</u>
<u>Hartland, WI 53029</u>	<u>Port Washington, WI 53074</u>

CONTACT PERSON: Greg Fax and Mark Goetzinger, St. John Properties, Inc.

Address: 1020 James Drive, Suite G, Hartland, WI 53029

Phone: 262-524-0100 and 262-370-6855

Fax: 262-369-9075

E-mail address: gfax@sjpi.com and mgoetzinger@sjpi.com

**TYPE OF PROJECT:**  
(See Section A for:)

- Planned Unit Development (PUD)
  - General Development Plan (GDP)
  - Specific Implementation Plan (SIP)
- Planned Community Development (PCD)
  - General Development Plan (GDP)
  - Specific Implementation Plan (SIP)
- Planned Residential Development (PRD)
- New Construction or Exterior Remodeling in an Urban Design District \* (A public hearing is required as well as a fee)
- School, Public Building or Space (Fee may be required)
- New Construction or Addition to or Remodeling of a Retail, Hotel or Motel Building Exceeding 40,000 Sq. Ft.
- Planned Commercial Site

(See Section B for:)

- New Construction or Exterior Remodeling in C4 District (Fee required)

(See Section C for:)

- R.P.S.M. Parking Variance (Fee required)

(See Section D for:)

- Comprehensive Design Review\* (Fee required)
- Street Graphics Variance\* (Fee required)
- Other \_\_\_\_\_

\*Public Hearing Required (Submission Deadline 3 Weeks in Advance of Meeting Date)

Where fees are required (as noted above) they apply with the first submittal for either initial or final approval of a project.



St John Properties, Inc.  
1020 James Dr., Suite G  
Hartland, WI 53029

Mark Goetzinger  
262-370-6855 ©  
262-369-0100 Office  
262-369-9075 FAX  
Email: mgoetzinger@sjpi.com

## MEMO

**To:** Al Martin, Urban Design Secretary  
Urban Design Commission  
City of Madison Zoning Department  
215 Martin Luther King, Jr. Blvd.  
PO Box 2984  
Madison, WI 53701-2984

**From:** Mark Goetzinger

**Date:** October 3, 2012

**Re:** APPLICATION FOR URBAN DESIGN COMMISSION – Final Approval  
Proposed Development – Voges Road Business Center  
4800 & 4950 Voges Road

We are requesting review and approval of the above referenced development, specifically for approval of Phase 1 and the Overall Site Plan development concept. Accordingly, we are submitting our application and request that we be placed on the October 17<sup>th</sup> meeting agenda for UDC Final Approval. This application follows our Informational Presentation meeting on September 19<sup>th</sup>. The commission's input at the initial meeting has been addressed and is incorporated in our Final Approval application.

Documents accompanying our request for development approval are as follows:

- Application for Urban Design Commission – Final Approval
- Application Package: Project Description, Plans and Details as outlined in this memo, dated October 3<sup>rd</sup>, 2012.
- Electronic Application Submittal – PDF format

### APPLICATION PACKAGE

#### 1. Project Description

- a) Owner: St. John Properties, Inc., 1020 James Drive, Suite G, Hartland, WI 53029. Contact: Mark Goetzinger, 262-370-6855. [mgoetzinger@sjpi.com](mailto:mgoetzinger@sjpi.com).
- b) Architect: Haag-Muller Architects, Inc., 101 East Grand Avenue, Suite 1, Port Washington, WI 53074, 262-268-1200, [www.haagmuller.com](http://www.haagmuller.com).
- c) Overview of proposed development:
  - i. The proposed development consists of a roughly 35 acre parcel, currently undeveloped agricultural and wooded land that is split by a City of Madison wetland drainage corridor. Existing conditions are depicted in attached aerial exhibit, referenced "Existing Conditions".
  - ii. The development area is zoned M-1, Light Manufacturing and our proposed use complies with the zoning district designation.
  - iii. More specifically, the overall development layout is depicted in attached "Overall Site Plan" exhibit. There are a total of 6 office and warehouse style buildings, ranging from 18,000 SF to 50,900 SF in area. As part of the development, internal roads, storm water system and city utilities will be constructed and dedicated to the city. At this time, plans for the remaining parcel east of the City's drainage corridor have not been formulated.

- iv. Construction of the proposed development will occur in phases. Phase 1 involves construction of the 2 southern buildings on the parcel, along with the storm water pond that serves these buildings, as well as, future buildings when they are constructed. City utilities and roadway will be installed as required. Phase I is depicted on the “Phase 1 Site Plan”.
- v. Our application for UDC approval is twofold: (1) approval of Phase 1, and (2) approval of “Overall Site Plan”, recognizing that areas outside of Phase 1 will be considered by the UDC at a later date for final review and approval.

**2. Neighboring Area**

- a) Photographs of neighboring buildings and businesses are shown in Exhibit “Neighborhood Photos”, sheets P1.1 through P1.4.
- b) Surrounding buildings are reflective of an M-1 zoning district. They are one story in height with generally flat roofs. Exterior finishes include masonry, stucco/EIFS, metal panels, etc. Most existing facilities provide on-site parking and truck operation areas.

**3. Building and Site Design Comments**

An essential element supporting office related functions is parking. It has been our experience that parking in the M-1 district has been inadequate for the type of uses in this district and to address this need we have increased the number of parking stalls above minimums called for in the zoning district.

Additionally, a critical component for the Warehouse/Flex building is a proper environment to support trucking—shipping and receiving for semi-tractor trailers and other vehicles common in M-1 zoning districts. Critical to truck traffic and associated difficult maneuvers is unobstructed pavement area in the principal courtyard that supports this activity. Accordingly, the courtyard provided for the Warehouse/Flex building is user friendly and common to this type of use. Prospective tenants are critical of this component and in the past they have expressed appreciation for the design reflected in this development.

A total of 30 bicycle spaces are incorporated on the grounds to accommodate one bicycle space for every 10 car stalls.

Specific site data for Phase 1 (Lot 1) and the remaining site is shown on the “Overall Site Plan”. This information includes: Property Area, Building Areas, Pavement Area, Green Area and Parking.

**4. Architecture – Description and Details**

- a) Building “A” is a multi-tenant office building with tenant entrances on both the north and south facades. As such, this building does not have a true back side. The building design utilizes an appealing rhythm of covered and recessed entrances, with four central tenant spaces flanked by four larger tenant spaces on each end. To provide interesting visual offsets and enhance views from Stoughton Road and Galleon Run, the larger tenant spaces on each end are provided with a higher parapet than the central spaces, and building “end” walls include bay projections with lower roof lines than the main building, similar to treatment on the front and rear elevations of building. The larger tenant spaces on each end are provided with a higher parapet than the central spaces to provide a visual offset. Exterior finish materials incorporate face brick on all four sides with attractive soldier course accent bands. The accent bands are further used to delineate the signage area. Masonry materials will be the same for all buildings within the Business Center. Windows and entrance doors will have a bronze tint (for enhanced thermal performance), and will be set into dark bronze aluminum frames. Parapets are capped with prefinished aluminum coping to match the window frames.

- b) Building “B” is a multi-tenant office and warehouse building with tenant entrances on the south façade, and trucking operations on the north side that include overhead doors and truck docks. This building design utilizes a rhythm of recessed entrances, combined with a staggered footprint to allow visual relief. Both the southeast and southwest corners incorporate an attractive recessed glass treatment, which serves to visually anchor the corners and to offer an appealing focal point to the building from Stoughton Road and Galleon Run. Exterior finish materials used incorporate face brick on the front/south façade and side facades, and, integrally-colored concrete block on the rear/north façade. Masonry accent bands are provided around the entire building, stepping up and down to frame out wall signage areas. Masonry materials will be the same for all buildings within the Business Center. Windows and entrance doors will have a bronze tint (for enhanced thermal performance), and will be set into dark bronze aluminum frames. Parapets are capped with prefinished aluminum coping to match the window frames.
- c) Trash Enclosure. The trash enclosure will be 6-feet high, and materials will be the same as the building for continuity, namely face brick with prefinished aluminum coping. Gates will be cedar on structural metal frame and 6-inch hinge bollards.
- d) HVAC Screening. In Phase 1 HVAC screening is provided for the south building along Voges Road. This building could be considered as the “entrance” building to the business center. The warehouse/flex building to the north does not have screening for several reasons. Most importantly, the roof top units are essentially not visible based on sight line study—please see attached illustration of sight lines. Also, please note this building is on interior of park, it is not parallel to road, and roof top HVAC units are positioned within the center area of buildings to prevent viewing.

**5. Description of Proposed Development Signage:**

- a) Overview of Sign Package.
  - i. All signs shown comply with City of Madison Sign Ordinance
- b) A sign package is attached that includes the following:
  - i. “Site Plan – Site Signage” sheet S1.1, illustrates locations of Directory Signs.
  - ii. “Directory Sign Design Details”, sheet S1.2
  - iii. “Building Wall Signs”
    - a. Building signage. See Building Signage Elevation drawings, sheet S1.3.
    - b. Window & Door signs. See Building Signage Elevation drawings, sheet S1.3.
    - c. Building Address Numbers. See Building Signage drawings, sheet S1.2. Building addresses shall consist of 18” high numbers, white, as called out on building elevations.

**6. Site & Exterior Building Lighting.**

The site is generally illuminated by use of wall mounted light fixtures that are spaced around the perimeter of each building. These fixtures are mounted generally at a height of 16 ft. and illuminate parking and sidewalk areas. This lighting scheme has proven very suitable for tenants at our other facilities. The fixtures are “cutoff fixtures” and do not cast any glaring light to abutting properties. Fixture specifications and drawing illustrating illumination is included in accompanying materials.

**7. Landscape Plan.**

- a) Landscape Design Plan attached.
- b) Description of Landscape Design.

The landscape design philosophy for this project was threefold: 1) to provide a simple but tasteful site and foundation planting plan that compliments the building architecture and accents the entrance, 2) provide adequate screening of the building from South Voges Road and South Dutch Mill Road and from adjacent properties, and 3) provide a variety of colorful and interesting plants and amenities to highlight entrance areas, the proposed patio area, and identifying signs.

The canopy, ornamental and evergreen trees are a mixture of native species and cultivars that are popular, aesthetically pleasing, hardy, and easy to maintain. The screening plants are a mixture of hardy native plants and commonly used colorful ornamental shrubs and perennials that provide an effective visual barrier that is also aesthetically pleasing. The foundation plantings include a variety of colorful ornamental shrubs and perennials, as well as hardy evergreens. The front yard and side yards include hardy and attractive shade and ornamental trees as well as groupings of shrubs and perennials. The parking lots and semi loading areas are heavily screened with large scale native canopy trees, evergreen trees, and shrubs. The monument sign is landscaped with distinctive ornamental shrubs and perennials. The employee patio area is a stamped, colored concrete patio with a built-in picnic table, benches, and other typical amenities. It is landscaped with colorful shrubs and perennials. It is connected to the rest of the site via a concrete sidewalk. The berm around the storm water pond is planted with native and hardy trees, shrubs, and native turf that are compatible with wet, poorly drained soils and detention/retention facilities. Where ever possible and feasible native plant materials are used, particularly for screening. The foundation plantings, patio plantings, and sign plantings include non-native plantings that are colorful and attractive to tenants and users of the business center, and are 'signature plants' used by the owner at all of their other facilities.



# VOGES ROAD BUSINESS CENTER



1020 JAMES DRIVE SUITE G  
HARTLAND, WISCONSIN 53029  
262.524.0100

4800 & 4950 VOGES ROAD  
MADISON, WISCONSIN 53597



**haag müller, inc.**

Architecture ■ Engineering ■ Interiors

101 East Grand Avenue, Suite 1  
Port Washington, Wisconsin 53074  
262.268.1200 www.haagmuller.com

COPYRIGHT 2012 © - All Rights Reserved

TABLE OF CONTENTS	
No.	Sheet Title
<b>GENERAL</b>	
	URBAN DESIGN COMMISSION APPLICATION
	COVER LETTER
	COVER SHEET, TABLE OF CONTENTS
<b>SITE WORK</b>	
C1.0	OVERALL SITE PLAN
C1.1	PHASE 1 SITE PLAN
C2.1	PHASE 1 SITE GRADING PLAN
L1.0	LANDSCAPE PLAN
T1.0	TRASH ENCLOSURE DETAILS
<b>ARCHITECTURAL</b>	
A1.1	FLOOR PLAN - OFFICE BUILDING 'A'
A1.2	FLOOR PLAN - WAREHOUSE BUILDING 'B'
A3.1	ELEVATIONS - OFFICE BUILDING 'A'
A3.2	ELEVATIONS - WAREHOUSE BUILDING 'B'
A4.1	SIGHTLINE STUDY - OFFICE BUILDING 'A'
A4.2	SIGHTLINE STUDY - WAREHOUSE BUILDING 'B'
S1.1	SITE SIGNAGE PLAN
S1.2	SITE SIGNAGE ELEVATIONS
S1.3	BUILDING SIGN ELEVATIONS
S1.4	SIGNAGE DIAGRAMS
P1.1	NEIGHBORHOOD PHOTOS KEY PLAN
P1.2	NEIGHBORHOOD PHOTOS
P1.3	NEIGHBORHOOD PHOTOS
P1.4	NEIGHBORHOOD PHOTOS
	SITE ILLUMINATION DIAGRAM
	BLDG. WALL LIGHT FIXTURE CUT SHEET

### SITE AREAS

#### LOT 1:

PROPERTY AREA = 631,595 S.F. 14.50 ACRES  
 BUILDING = 164,360 S.F.  
 PAVEMENT = 336,577 S.F.  
 TOTAL IMPERVIOUS AREA = 500,937 S.F. 11.50 ACRES  
 GREEN SPACE = 130,658 S.F. 3.00 AC. (21% OF SITE)

#### PARKING:

545 REGULAR SPACES  
 14 HANDICAPPED SPACES  
 TOTAL PARKING SPACES = 559

#### LOT 2:

PROPERTY AREA = 59,240 S.F. 1.36 ACRES  
 BUILDING = 18,020 S.F.  
 PAVEMENT = 18,621 S.F.  
 TOTAL IMPERVIOUS AREA = 36,641 S.F. 0.84 ACRES  
 GREEN SPACE = 22,599 S.F. 0.52 AC. (38% OF SITE)

#### PARKING:

29 REGULAR SPACES  
 2 HANDICAPPED SPACES  
 TOTAL PARKING SPACES = 31

#### LOT 3:

PROPERTY AREA = 271,002 S.F. 6.22 ACRES  
 BUILDING = 47,900 S.F.  
 PAVEMENT = 124,235 S.F.  
 TOTAL IMPERVIOUS AREA = 172,135 S.F. 3.95 ACRES  
 GREEN SPACE = 98,867 S.F. 2.27 AC. (36% OF SITE)

#### PARKING:

129 REGULAR SPACES  
 5 HANDICAPPED SPACES  
 TOTAL PARKING SPACES = 134

#### LOT 4:

PROPERTY AREA = 272,016 S.F. 6.24 ACRES  
 (100% GREEN SPACE)

#### OUTLOT 1:

PROPERTY AREA = 162,700 S.F. 3.735 ACRES  
 (100% GREEN SPACE)

#### NEW PUBLIC RIGHT-OF-WAY:

PROPERTY AREA = 120,605 S.F. 2.77 ACRES

#### TOTAL PROJECT PROPERTY AREA

= 1,517,158 S.F. 34.83 ACRES

### PHASE 1 SITE AREAS

#### LOT 1:

PROPERTY AREA = 338,245 S.F. 7.765 ACRES  
 BUILDING = 82,180 S.F.  
 PAVEMENT = 187,190 S.F.  
 TOTAL IMPERVIOUS AREA = 269,370 S.F. 6.18 ACRES  
 GREEN SPACE = 68,875 S.F. 1.58 AC. (20% OF SITE)

#### PARKING:

282 REGULAR SPACES  
 7 HANDICAPPED SPACES  
 REQUIRED SPACES = 206 (BASED ON OFFICE LAND USE)  
 TOTAL PARKING SPACES PROVIDED = 289  
 BIKE SPACES = 30

#### OUTLOT 1:

PROPERTY AREA = 162,700 S.F. 3.735 ACRES  
 (100% GREEN SPACE)

#### GALLEON ROAD RIGHT-OF-WAY:

PAVEMENT AREA = 27,663 S.F. 0.635 ACRES

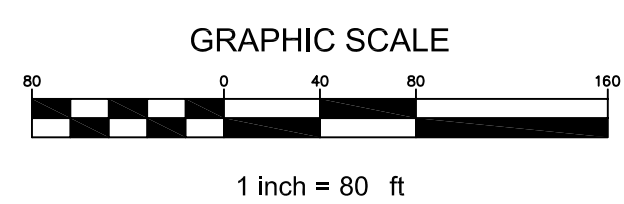
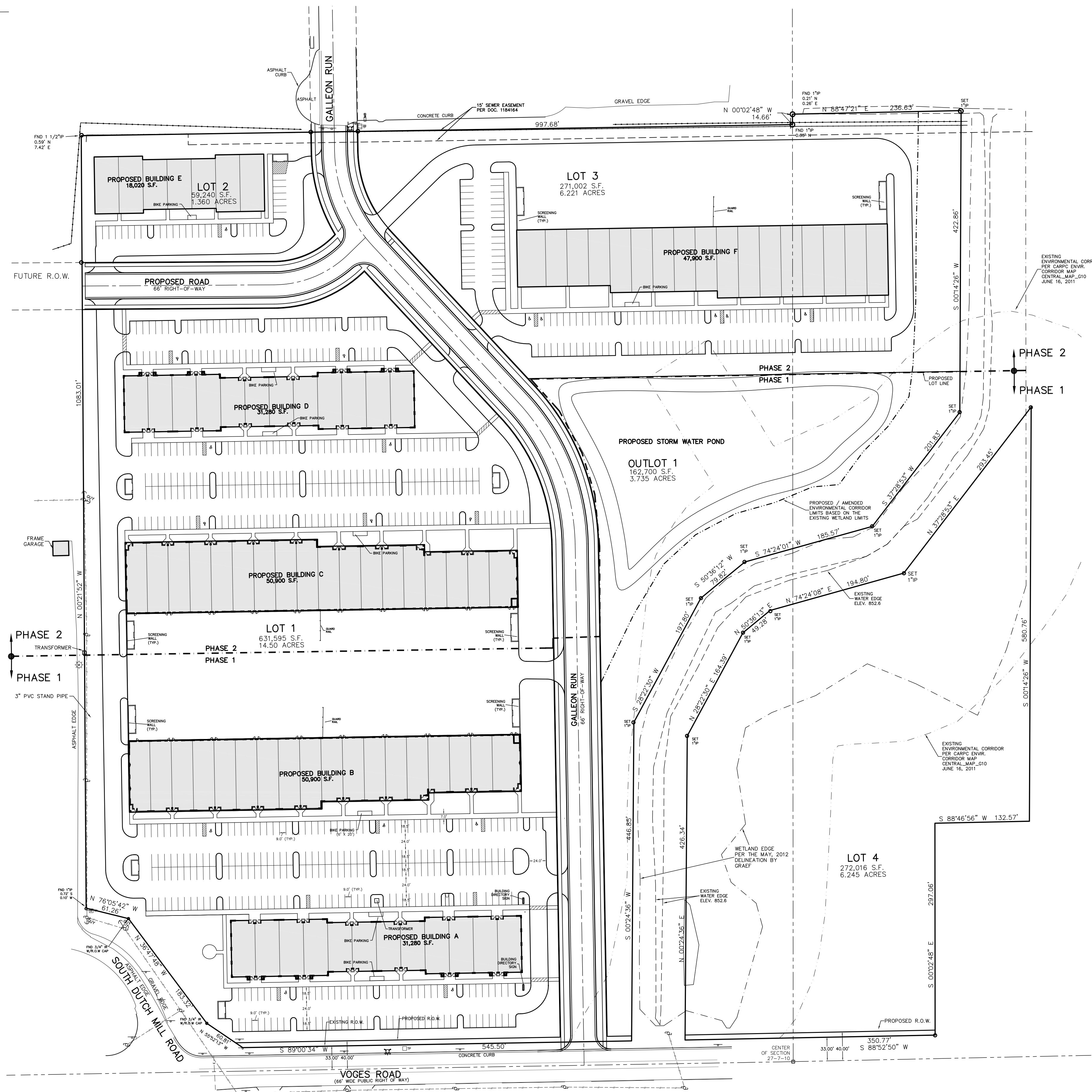
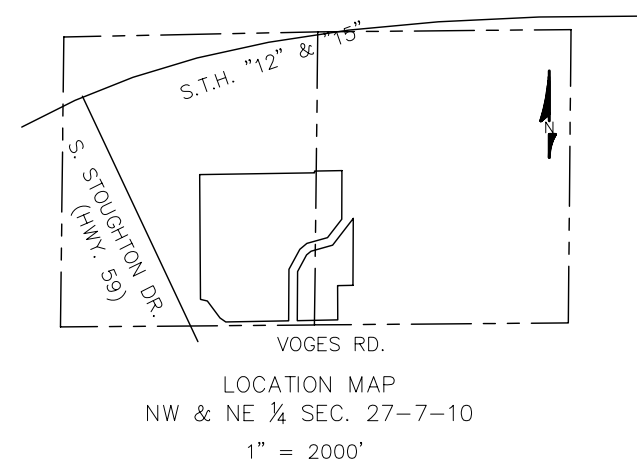

haag müller, inc.  
 Architecture • Engineering • Interiors

101 East Grand Avenue, Suite 1  
 Port Washington, Wisconsin 53074  
 262.268.1200 www.haagmuller.com  
 COPYRIGHT 2002 © All Rights Reserved



1020 JAMES DRIVE SUITE G  
 HARTLAND, WISCONSIN 53029  
 262.524.0100

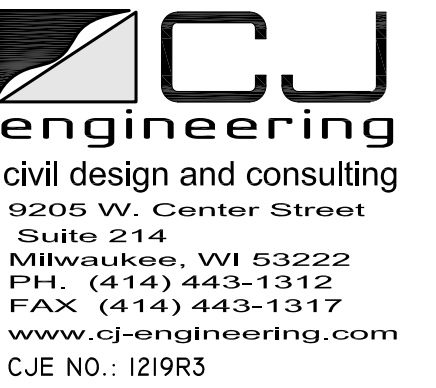

VOGES ROAD BUSINESS CENTER  
 4800 & 4950 VOGES ROAD  
 MADISON, WISCONSIN

REVISIONS	
NO.	DESCRIPTION

DATE: 9-24-12  
 PROJ. NO: 1208138  
 DRAWN BY: C.A.J.  
 SHEET

**PHASE 1 SITE AREAS**

**LOT 1:**

PROPERTY AREA = 338,245 S.F. 7.765 ACRES  
 BUILDING = 82,180 S.F.  
 PAVEMENT = 187,190 S.F.  
 TOTAL IMPERVIOUS AREA = 269,370 S.F. 6.18 ACRES  
 GREEN SPACE = 68,875 S.F. 1.58 AC. (20% OF SITE)

**PARKING:**

282 REGULAR SPACES  
 7 HANDICAPPED SPACES  
 REQUIRED SPACES = 206 (BASED ON OFFICE LAND USE)  
 TOTAL PARKING SPACES PROVIDED = 289  
 BIKE SPACES = 30

**OUTLOT 1:**

PROPERTY AREA = 162,700 S.F. 3.735 ACRES  
 (100% GREEN SPACE)

**GALLEON ROAD RIGHT-OF-WAY:**

PAVEMENT AREA = 27,663 S.F. 0.635 ACRES

**LOT 1**  
 631,595 S.F.  
 14.50 ACRES

**OUTLOT 1**  
 162,700 S.F.  
 3.735 ACRES

**LOT 4**  
 272,016 S.F.  
 6.245 ACRES

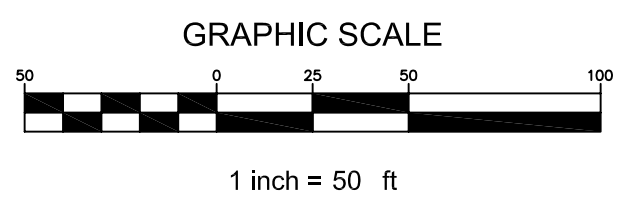
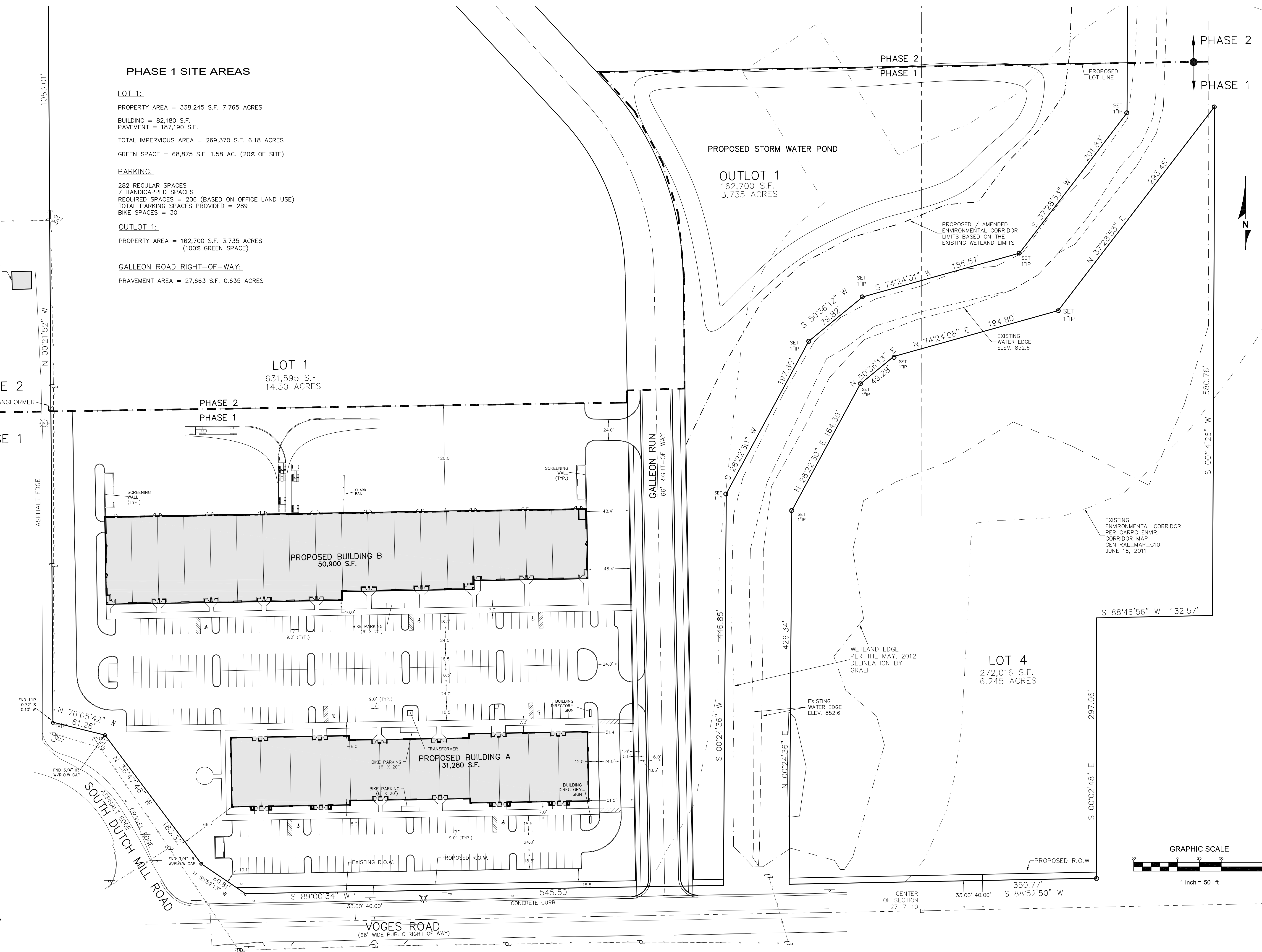

**PHASE I SITE PLAN**



**haag müller, inc.**  
 Architecture • Engineering • Interiors

101 East Grand Avenue, Suite 1  
 Port Washington, Wisconsin 53074  
 262.268.1200 www.haagmuller.com  
 COPYRIGHT 2002 © - All Rights Reserved



1020 JAMES DRIVE SUITE G  
 HARTLAND, WISCONSIN 53029  
 262.524.0100

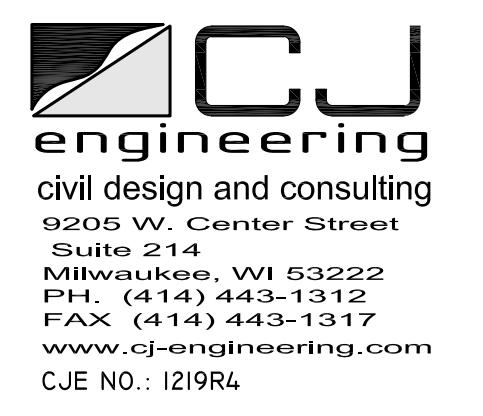

**CJ engineering**  
 civil design and consulting  
 9209 W. Center Street  
 Suite 214  
 Milwaukee, WI 53222  
 PH: (414) 443-1312  
 FAX: (414) 443-1317  
 www.cj-engineering.com  
 CJE NO.: I219R4

**VOGES ROAD BUSINESS CENTER**  
 4800 & 4950 VOGES ROAD  
 MADISON, WISCONSIN

REVISIONS	
NO.	DESCRIPTION

DATE: 9-24-12  
 PROJ. NO: 1208138  
 DRAWN BY: C.A.J.  
 SHEET

**C1.1**

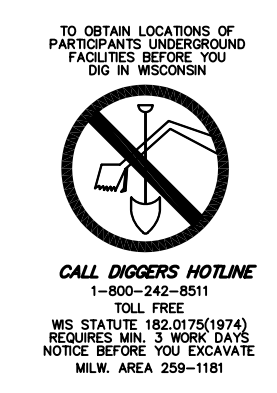





PLANT LIST

Table with columns: KEY, QUAN, SIZE, COMMON NAME, ROOT. Lists various plants such as Autumn Blaze Maple, Black Hills Spruce, and Dwarf Burning Bush.

NOTES:

- 1) Sodded lawn areas to receive a minimum of 4" of topsoil, starter fertilizer, and locally grown bluegrass sod.
2) Sodded lawn areas to receive a minimum of 4" of topsoil, seed (Madison Parks), starter fertilizer, and straw mulch.
3) Sodded areas in drainage swales and slopes greater than 3:1 shall be mulched with Curlex erosion control fabric...

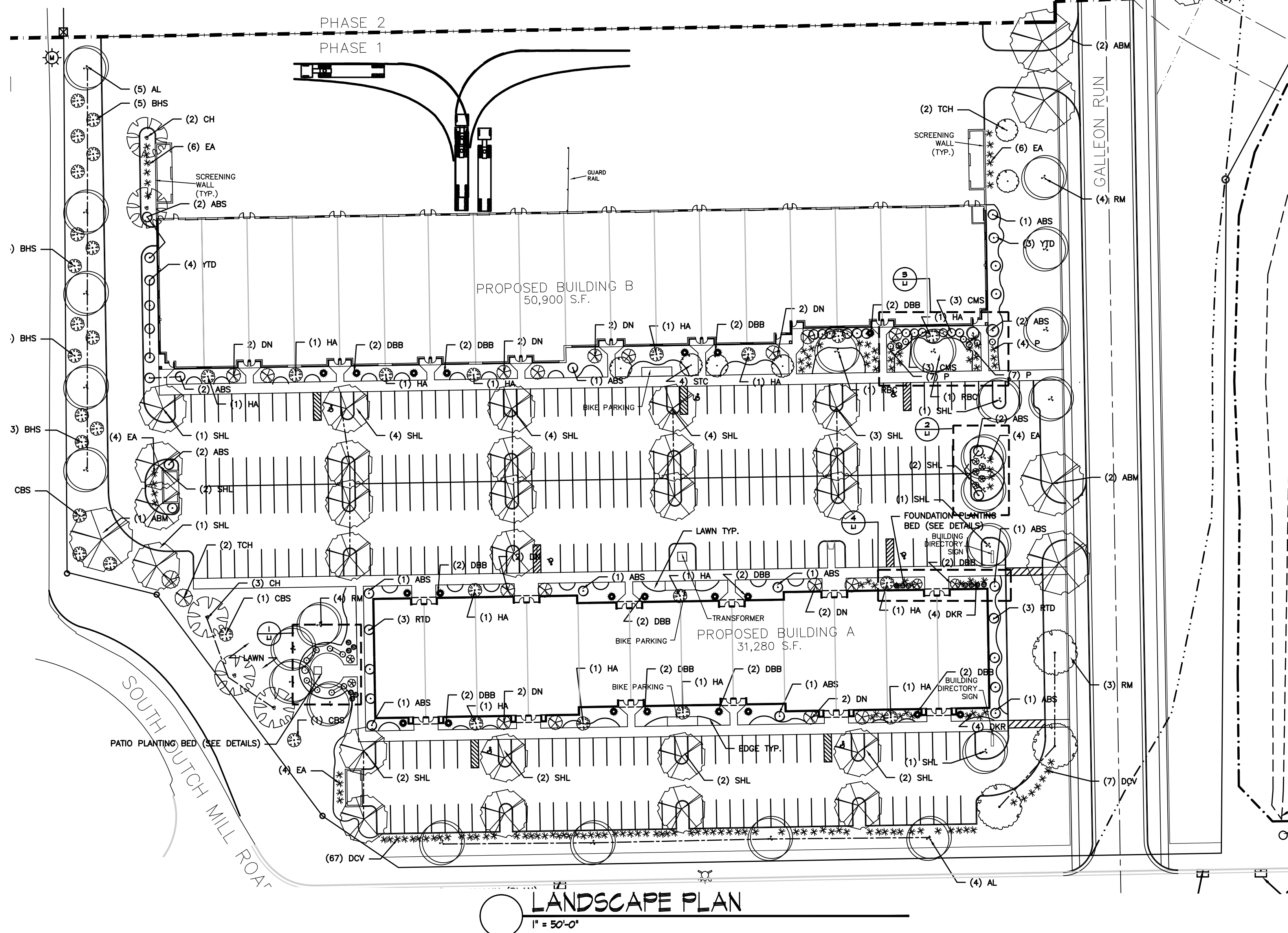

LANDSCAPE PLAN 1" = 50'-0"

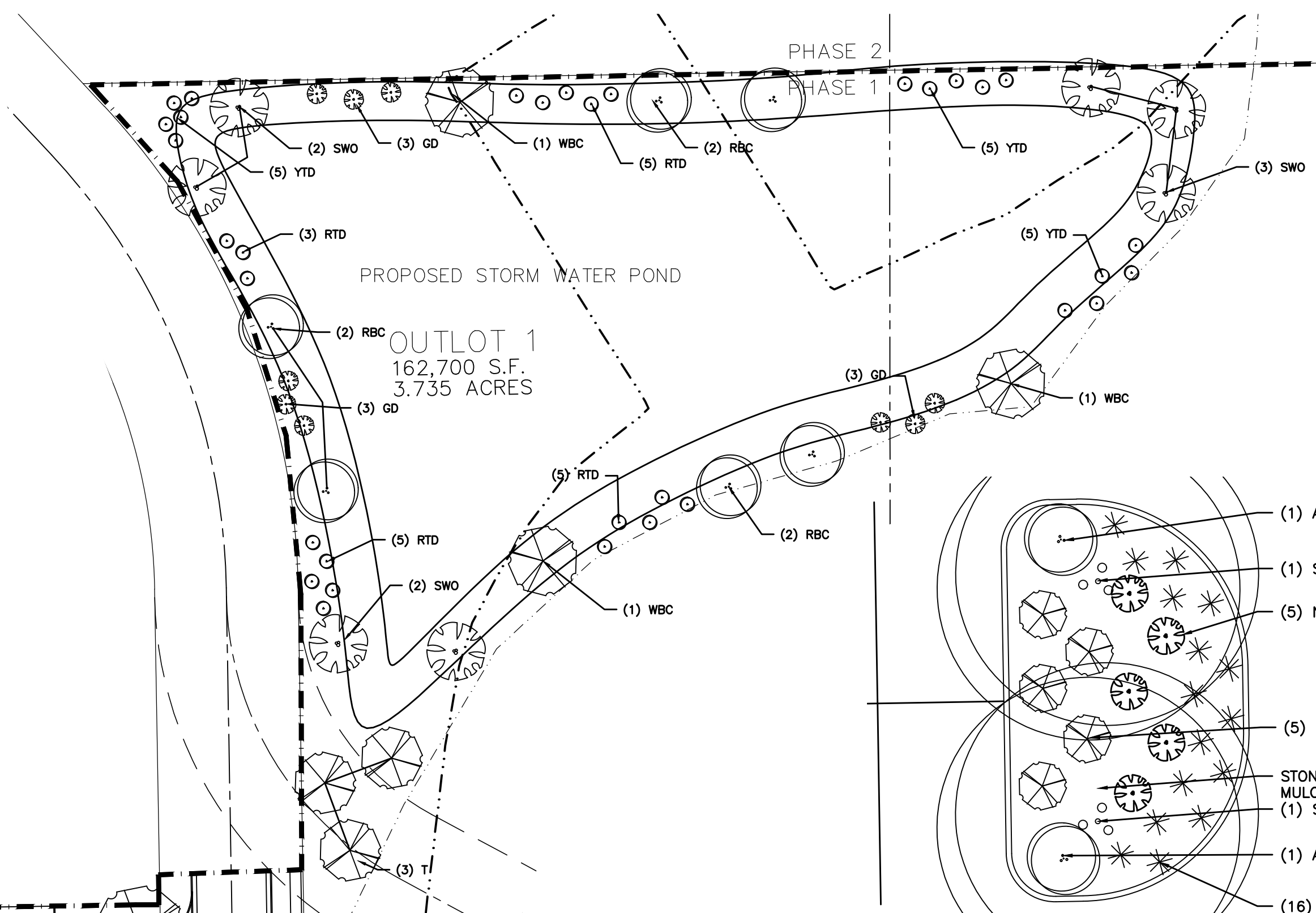

2 ENTRANCE PLANTER DETAIL 1" = 10'-0"

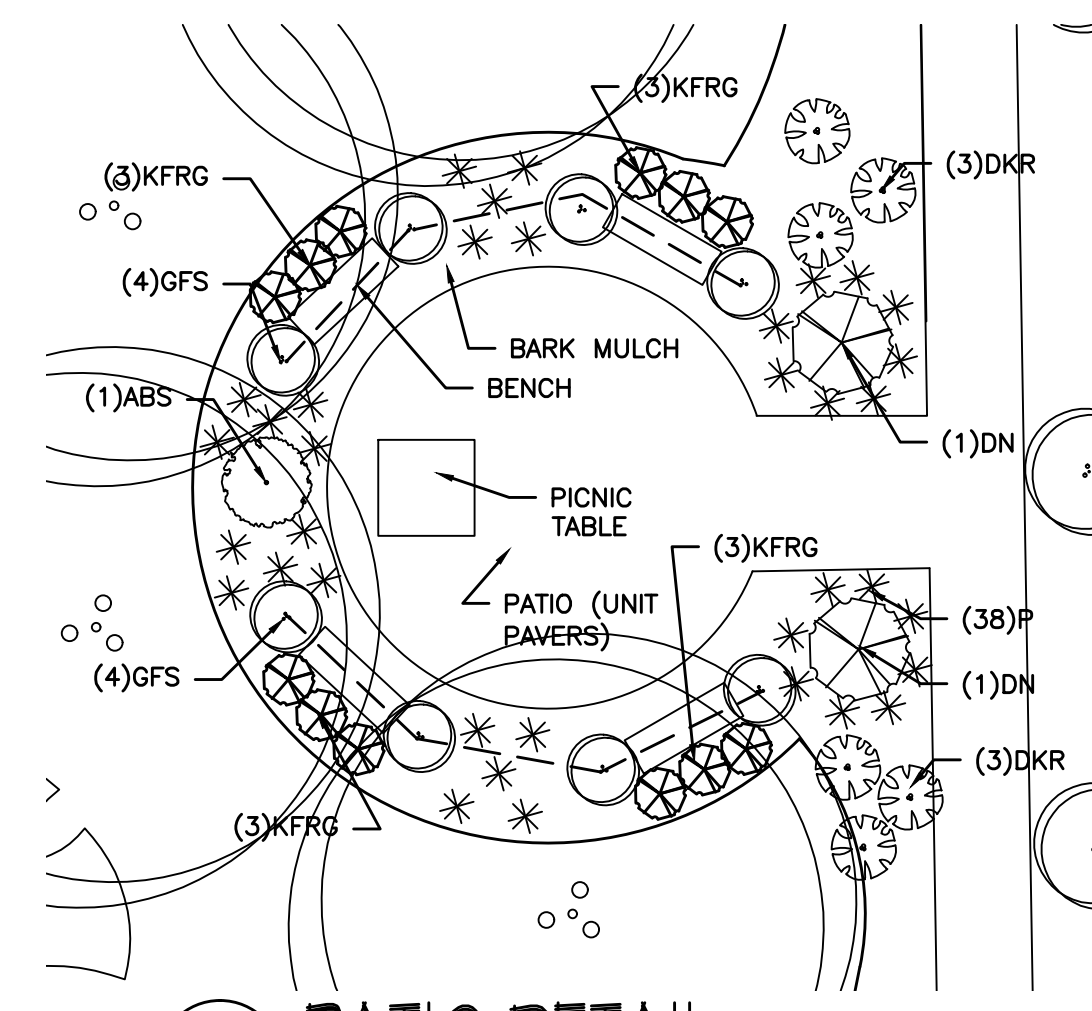

1 PATIO DETAIL 1" = 10'-0"

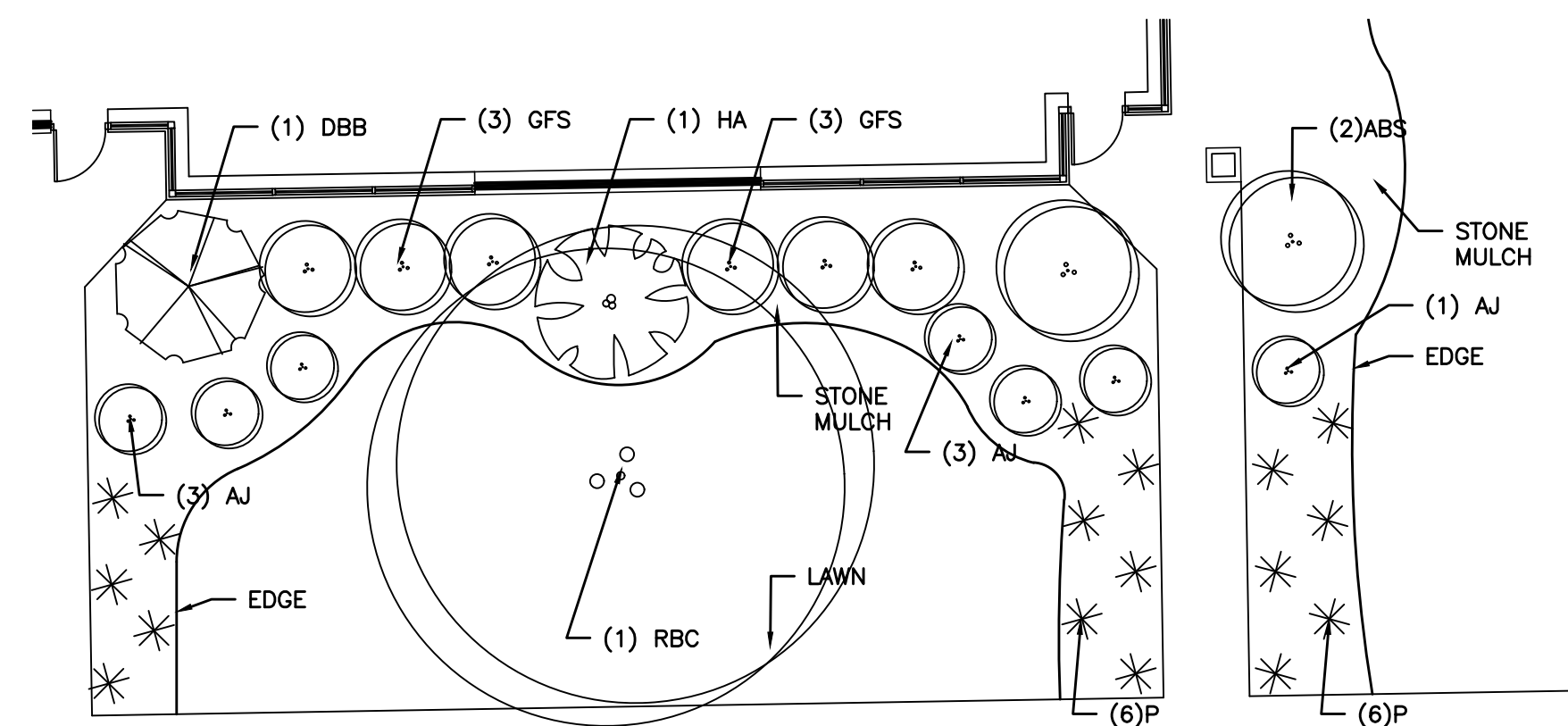

3 FOUNDATION PLANTING PLAN 1" = 10'-0"

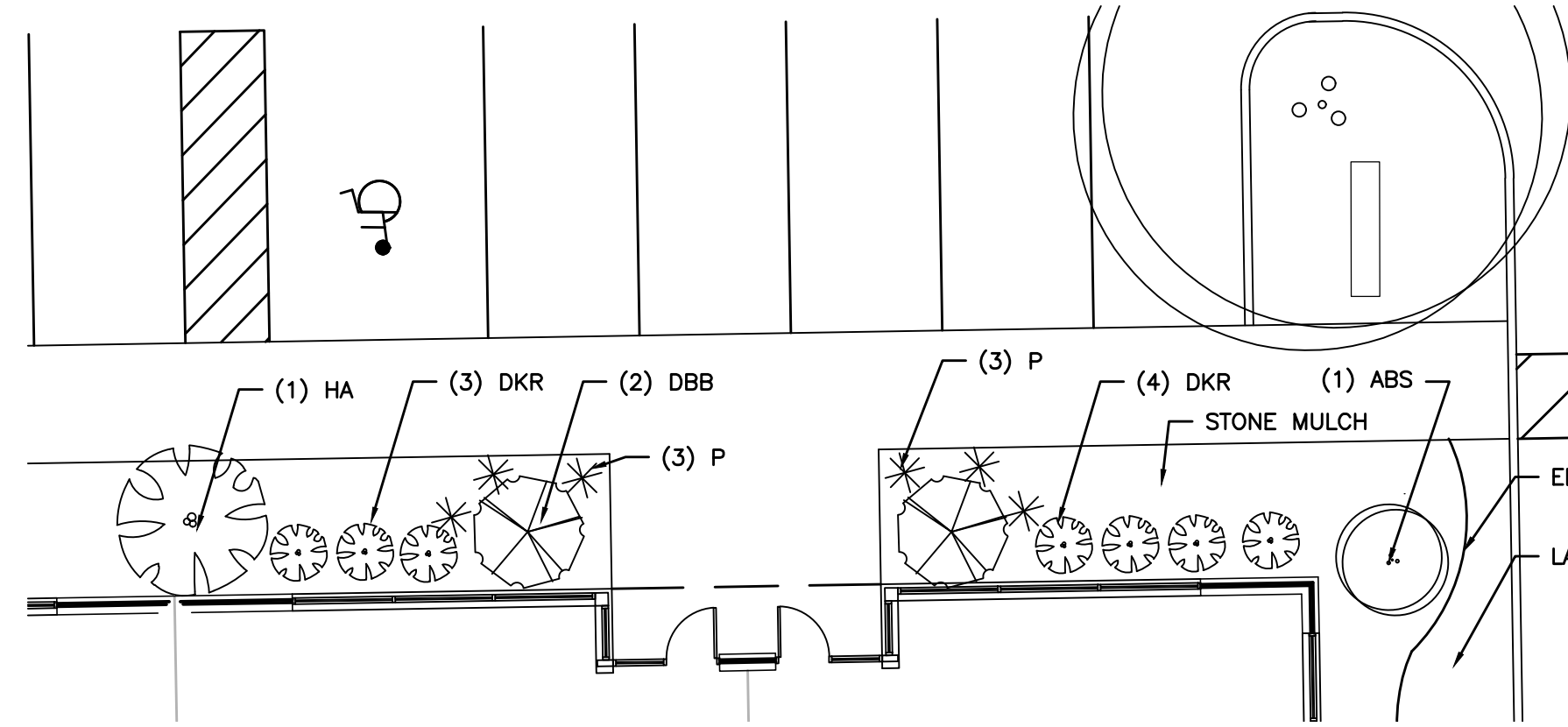

4 FOUNDATION PLANTING PLAN 1" = 10'-0"

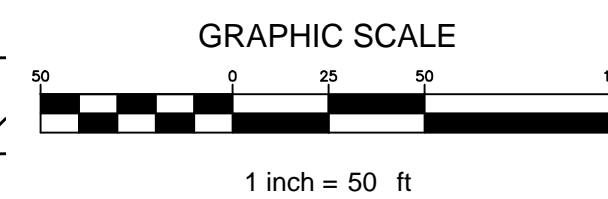

LANDSCAPE PLAN

S.P.S.

Paul Skidmore, Landscape Architect LLC

Paul Skidmore, ASLA

13001 Maple Trail (608) 836-0032
Madison, WI 53717 (608) 335-1529 (c)
paulskidmore@tss.net

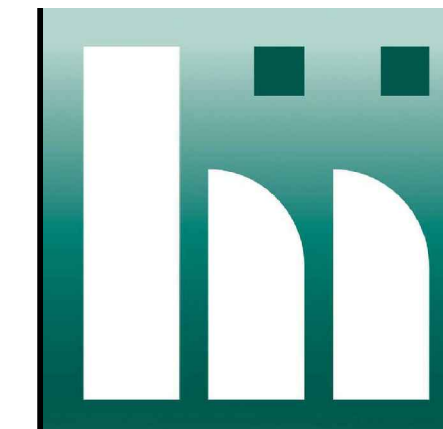

haag müller, inc.

Architecture • Engineering • Interiors

101 East Grand Avenue, Suite 1
Portland Washington, Wisconsin 53074
262.268.1200 www.haagmuller.com
COPYRIGHT 2002 © - All Rights Reserved

STJOHN PROPERTIES

1020 JAMES DRIVE SUITE G
HARTLAND, WISCONSIN 53029
262.524.0100

CJ engineering
civil design and consulting
9205 W. Center Street
Suite 214
Milwaukee, WI 53222
PH: (414) 443-1312
FAX: (414) 443-1317
www.cj-engineering.com
CJE NO.: 1219R3

VOGES ROAD BUSINESS CENTER
4800 & 4950 VOGES ROAD
MADISON, WISCONSIN

Table with columns: NO., DATE, DESCRIPTION, SHEET. Includes revision information and drawing details.

L1



haag müller, inc.

Architecture • Engineering • Interiors

101 East Grand Avenue, Suite 1  
Port Washington, Wisconsin 53074  
262.268.1200 www.haagmuller.com  
COPYRIGHT 2012 © - All Rights Reserved



1020 JAMES DRIVE SUITE G  
HARTLAND, WISCONSIN 53029  
262.524.0100

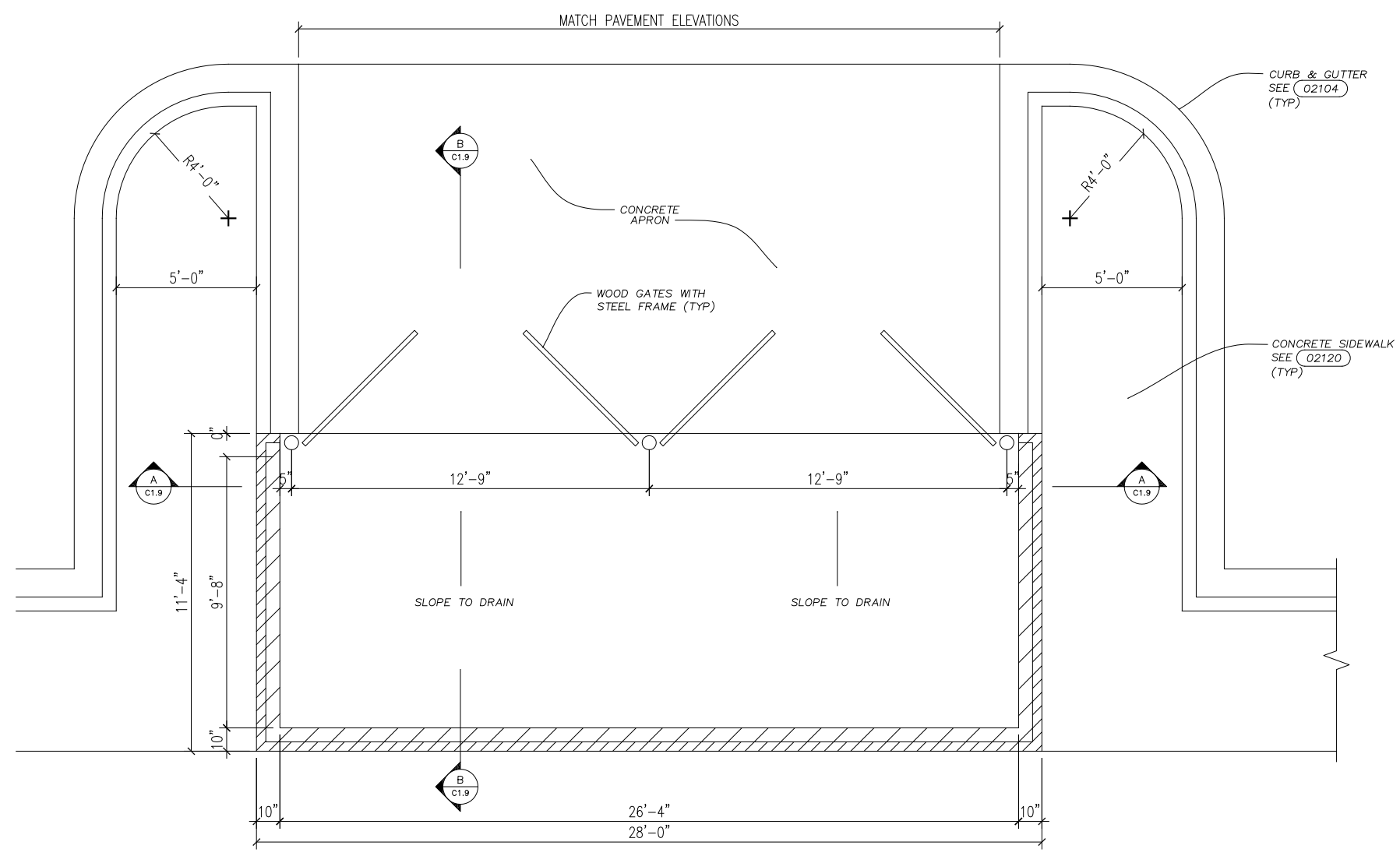

DETAIL 1  
3/16" = 1'-0"

TRASH ENCLOSURE DETAILS  
VOGES ROAD BUSINESS CENTER  
4800 & 4950 VOGES ROAD  
MADISON, WI

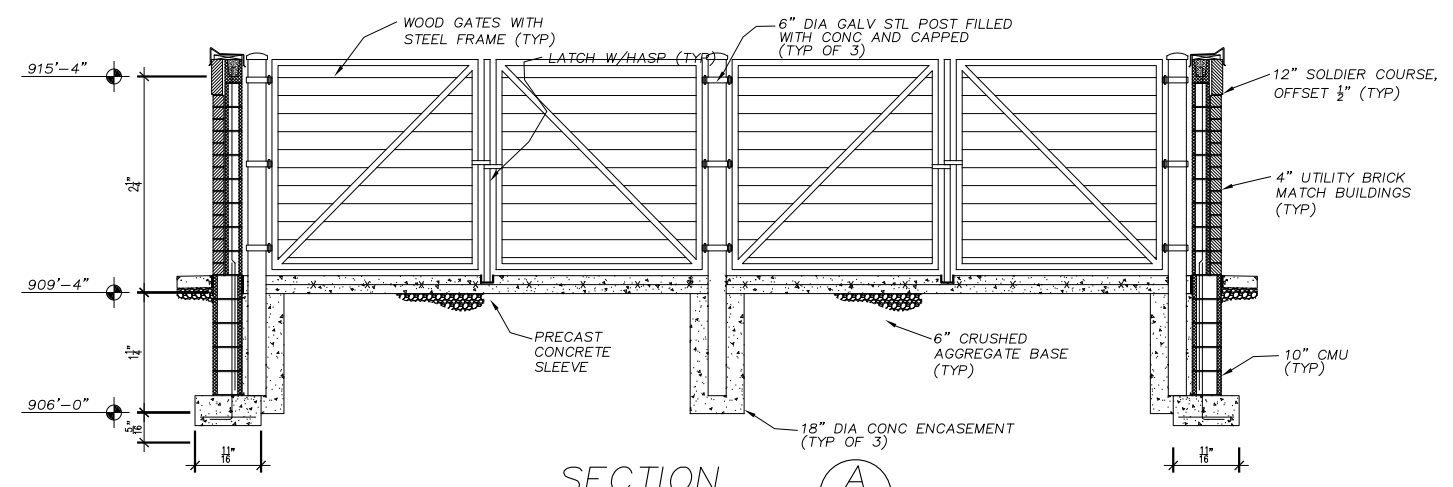

SECTION A  
3/16" = 1'-0"

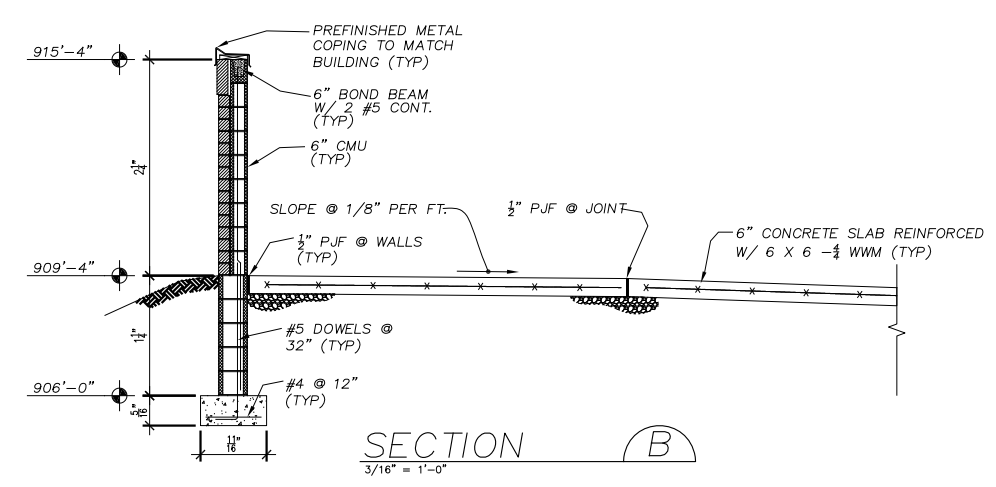

SECTION B  
3/16" = 1'-0"

DATE:	09-26-12
PROJ. NO.:	1208138
DRAWN BY:	JMH
SHEET	

T1.0



haag müller, inc.  
Architecture • Engineering • Interiors

101 East Grand Avenue, Suite 1  
Port Washington, Wisconsin 53074  
262.268.1200 www.haagmuller.com  
COPYRIGHT 2012 © - All Rights Reserved



1020 JAMES DRIVE SUITE G  
HARTLAND, WISCONSIN 53029  
262.524.0100

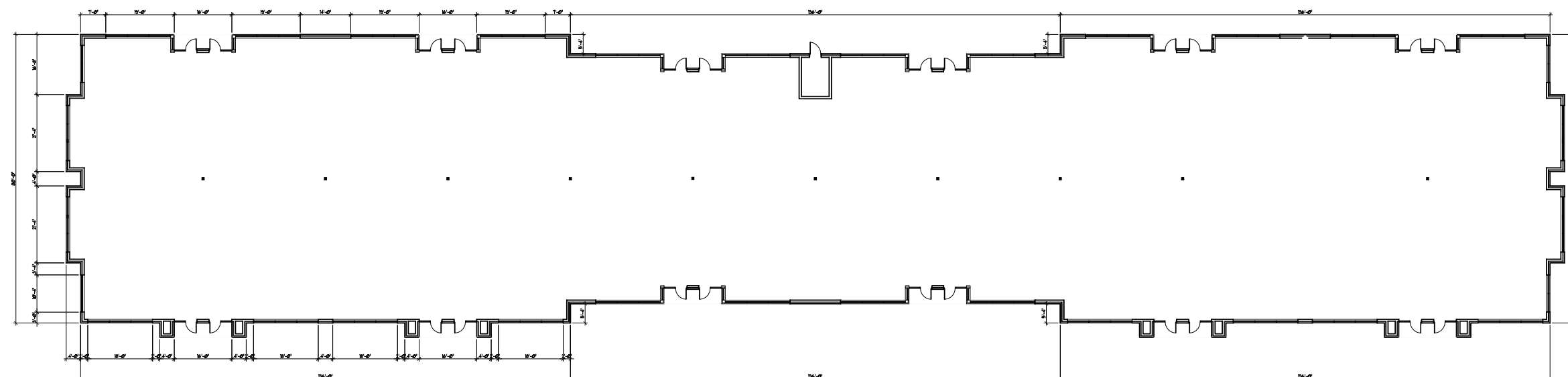

FLOOR PLAN



OFFICE BLDG. 'A' FLOOR PLAN  
VOGES ROAD BUSINESS CENTER  
4800 & 4950 VOGES ROAD  
MADISON, WISCONSIN

DATE:	9-26-12
PROJ. NO.:	1208138
DRAWN BY:	JMH
SHEET	
A1.1	



haag müller, inc.  
Architecture • Engineering • Interiors

101 East Grand Avenue, Suite 1  
Port Washington, Wisconsin 53074  
262.268.1200 www.haagmuller.com  
COPYRIGHT 2012 © - All Rights Reserved



1020 JAMES DRIVE SUITE G  
HARTLAND, WISCONSIN 53029  
262.524.0100

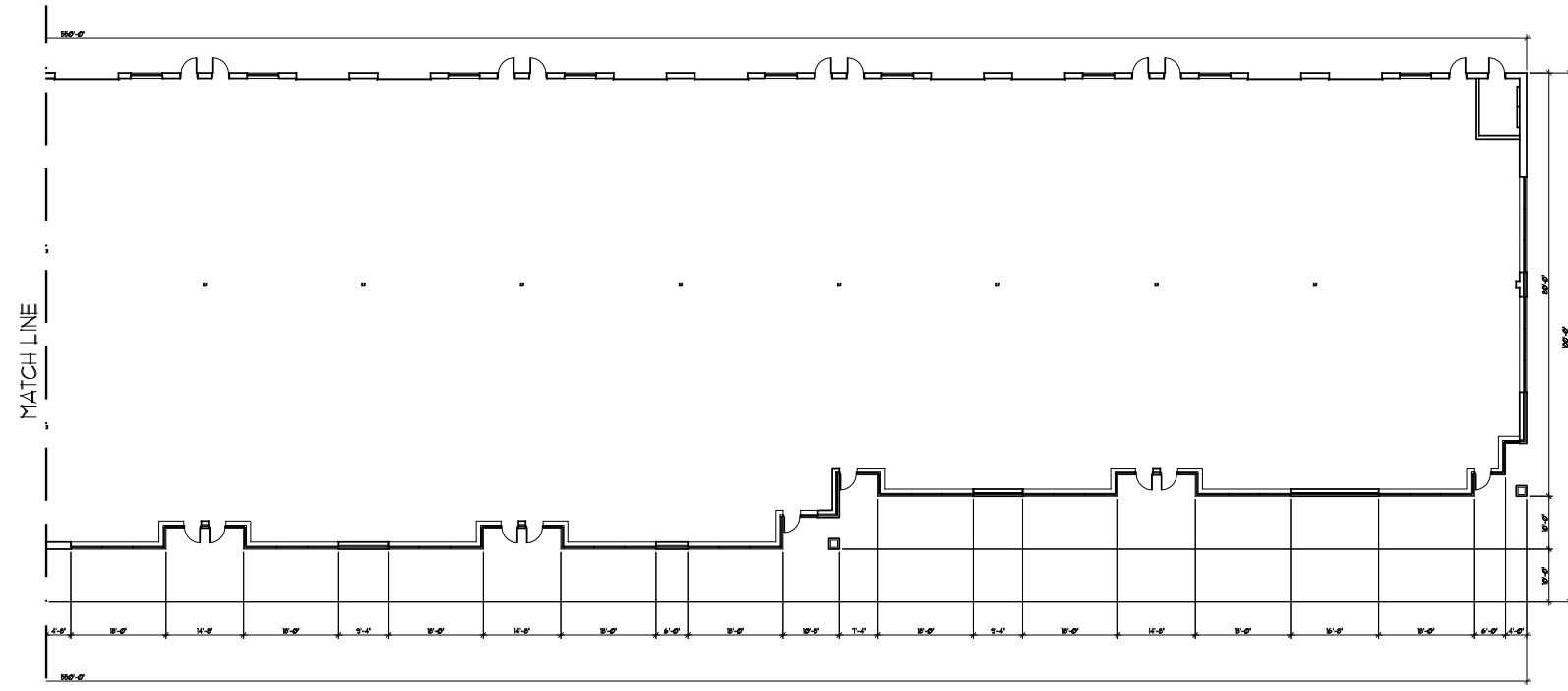

FLOOR PLAN - EAST

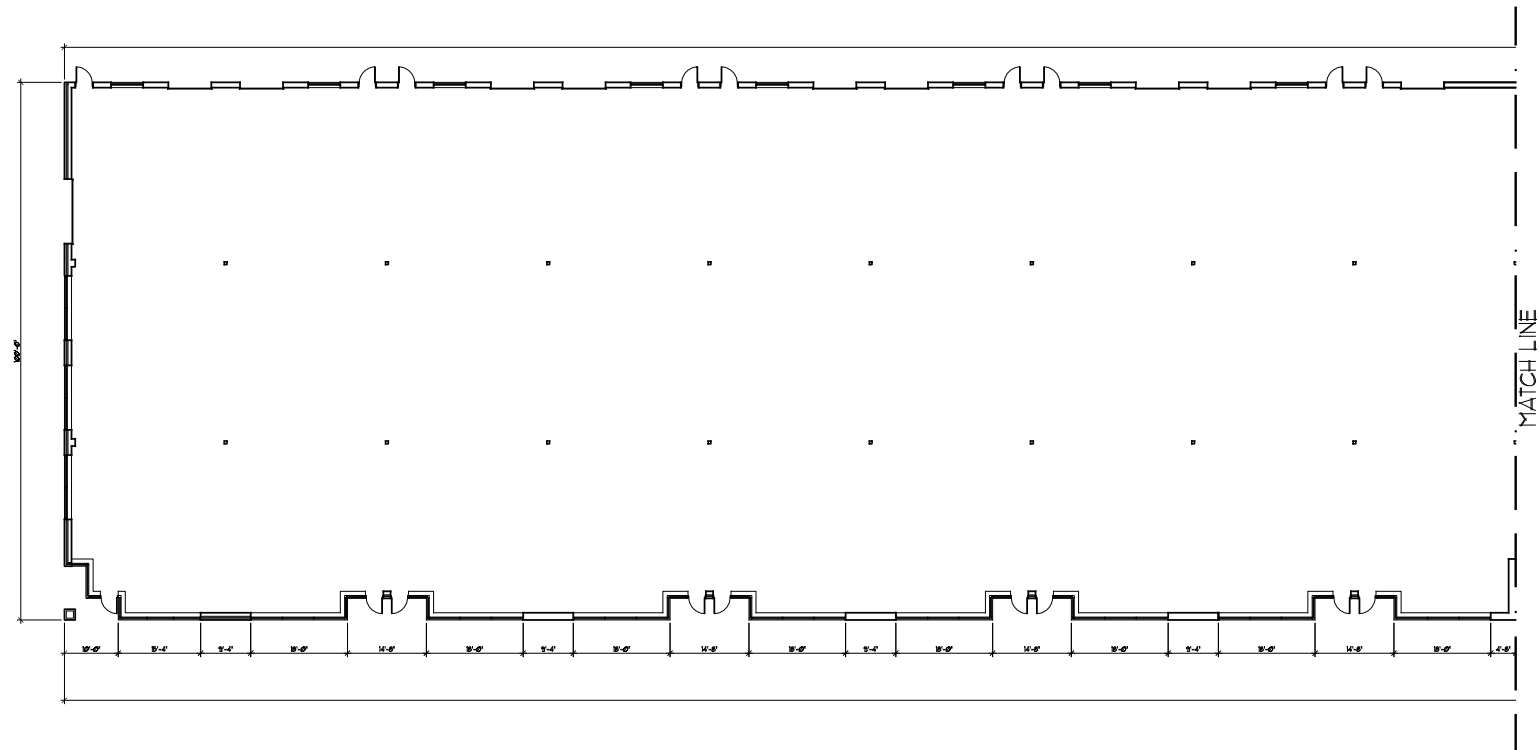

FLOOR PLAN - WEST



WAREHOUSE BLDG. 'B' FLOOR PLAN  
VOGES ROAD BUSINESS CENTER  
4800 & 4950 VOGES ROAD  
MADISON, WISCONSIN

DATE:	9-26-12
PROJ. NO.:	1208138
DRAWN BY:	JMH
SHEET	

A1.2



**SOUTH ELEVATION (LEFT)**

NOT TO SCALE



**SOUTH ELEVATION (RIGHT)**

NOT TO SCALE



**EAST ELEVATION**

NOT TO SCALE



**WEST ELEVATION**

NOT TO SCALE



**NORTH ELEVATION (LEFT)**

NOT TO SCALE



**NORTH ELEVATION (RIGHT)**

NOT TO SCALE



**haag müller, inc.**

Architecture • Engineering • Interiors

101 East Grand Avenue, Suite 1  
Port Washington, Wisconsin 53074  
262.268.1200 www.haagmuller.com  
COPYRIGHT 2012 © - All Rights Reserved



**ST. JOHN PROPERTIES**

1020 JAMES DRIVE SUITE G  
HARTLAND, WISCONSIN 53029  
262.524.0100

ELEVATIONS - BUSINESS BLDG "A"

VOGES ROAD BUSINESS CENTER

4800 & 4950 VOGES ROAD

MADISON, WISCONSIN

DATE:	9-26-12
PROJ. NO.:	1208138
DRAWN BY:	SPS
SHEET	

**A3.1**



**SOUTH ELEVATION (LEFT)**

NOT TO SCALE



**SOUTH ELEVATION (RIGHT)**

NOT TO SCALE



**EAST ELEVATION**

NOT TO SCALE



**WEST ELEVATION**

NOT TO SCALE



**NORTH ELEVATION (LEFT)**

NOT TO SCALE



**NORTH ELEVATION (RIGHT)**

NOT TO SCALE



**haag müller, inc.**

Architecture • Engineering • Interiors

101 East Grand Avenue, Suite 1  
Port Washington, Wisconsin 53074  
262.268.1200 www.haagmuller.com  
COPYRIGHT 2012 © - All Rights Reserved



**ST. JOHN PROPERTIES**  
1020 JAMES DRIVE SUITE G  
HARTLAND, WISCONSIN 53029  
262.524.0100

ELEVATIONS - WAREHOUSE BLDG "B"  
VOGES ROAD BUSINESS CENTER  
4800 & 4950 VOGES ROAD  
MADISON, WISCONSIN

DATE:	9-26-12
PROJ. NO.:	1208138
DRAWN BY:	SPS
SHEET	

**A3.2**



haag müller, inc.

Architecture • Engineering • Interiors

101 East Grand Avenue, Suite 1  
Port Washington, Wisconsin 53074  
262.268.1200 www.haagmuller.com  
COPYRIGHT 2012 © - All Rights Reserved



1020 JAMES DRIVE SUITE G  
HARTLAND, WISCONSIN 53029  
262.524.0100

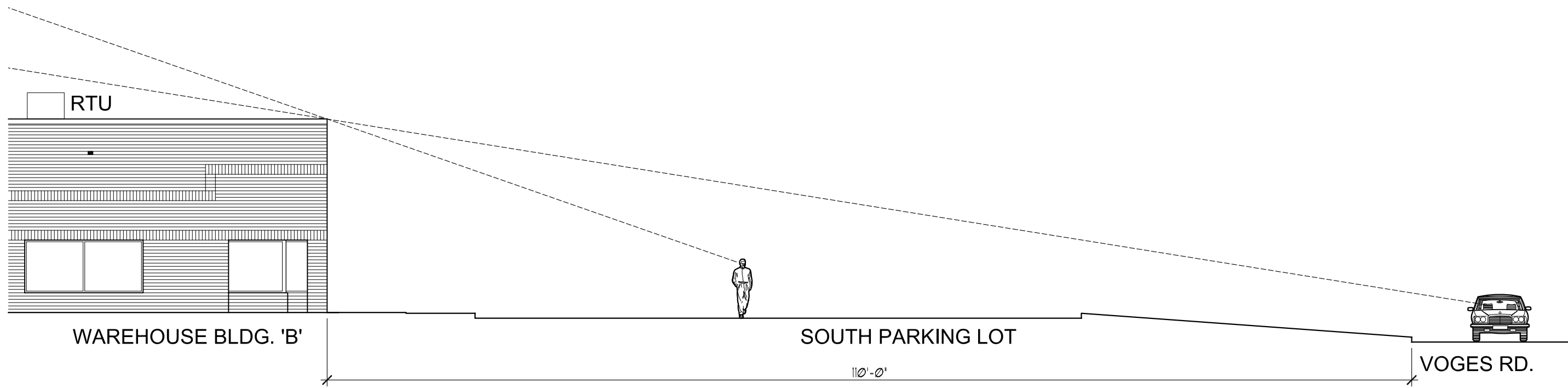

SIGHTLINE STUDY  
 VOGES ROAD BUSINESS CENTER  
 4800 & 4950 VOGES ROAD  
 MADISON, WI

# SIGHTLINE STUDY - WAREHOUSE BLDG 'B'

SCALE: 3/32" = 1'-0"

DATE:	09-26-12
PROJ. NO.:	1208138
DRAWN BY:	JMH
SHEET	

## A4.1





haag müller, inc.  
Architecture • Engineering • Interiors

101 East Grand Avenue, Suite 1  
Port Washington, Wisconsin 53074  
262.268.1200 www.haagmuller.com  
COPYRIGHT 2012 © - All Rights Reserved



1020 JAMES DRIVE SUITE G  
HARTLAND, WISCONSIN 53029  
262.524.0100

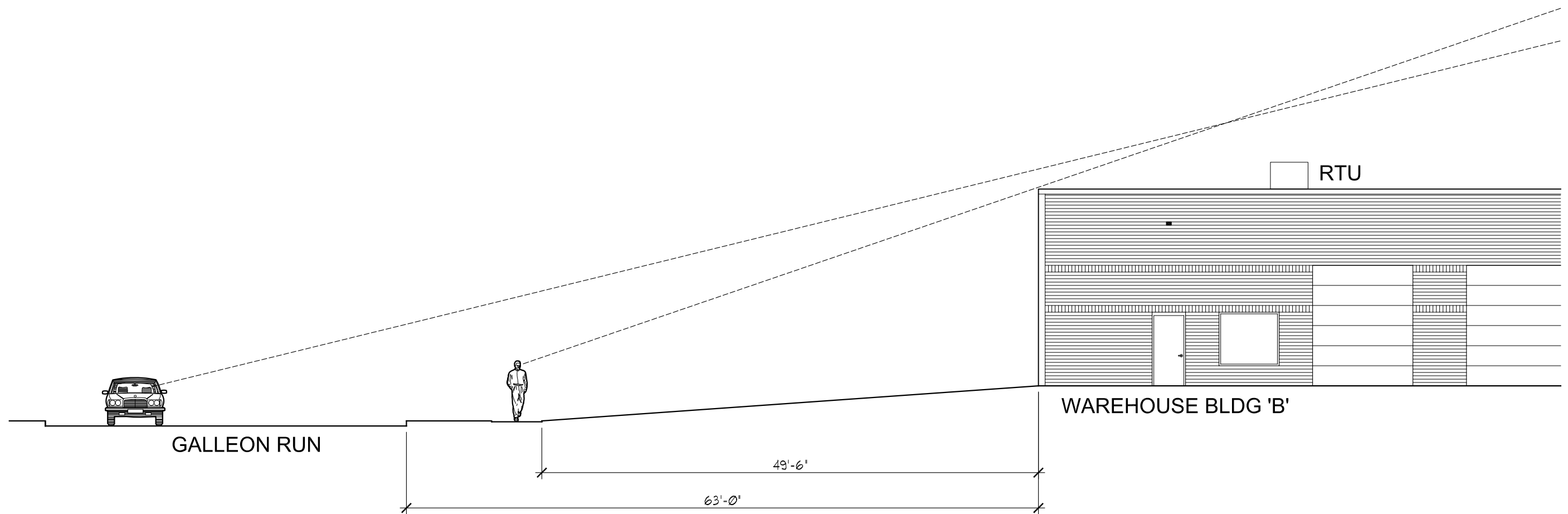

SIGHTLINE STUDY  
 VOGES ROAD BUSINESS CENTER  
 4800 & 4950 VOGES ROAD  
 MADISON, WI

# SIGHTLINE STUDY - WAREHOUSE BLDG 'B'

SCALE: 3/32" = 1'-0"

DATE:	09-26-12
PROJ. NO.:	1208138
DRAWN BY:	JMH
SHEET	

## A4.2



**haag müller, inc.**  
Architecture • Engineering • Interiors

101 East Grand Avenue, Suite 1  
Port Washington, Wisconsin 53074  
262.268.1200 www.haagmuller.com  
COPYRIGHT 2012 © - All Rights Reserved



**ST. JOHN PROPERTIES**  
1020 JAMES DRIVE SUITE G  
HARTLAND, WISCONSIN 53029  
262.524.0100

**SITE SIGNAGE PLAN KEY:**

- ① TENANT DIRECTORY SIGNAGE
- ② BUILDING ADDRESS
- ③ STOP SIGNS
- ④ ADA SIGNAGE

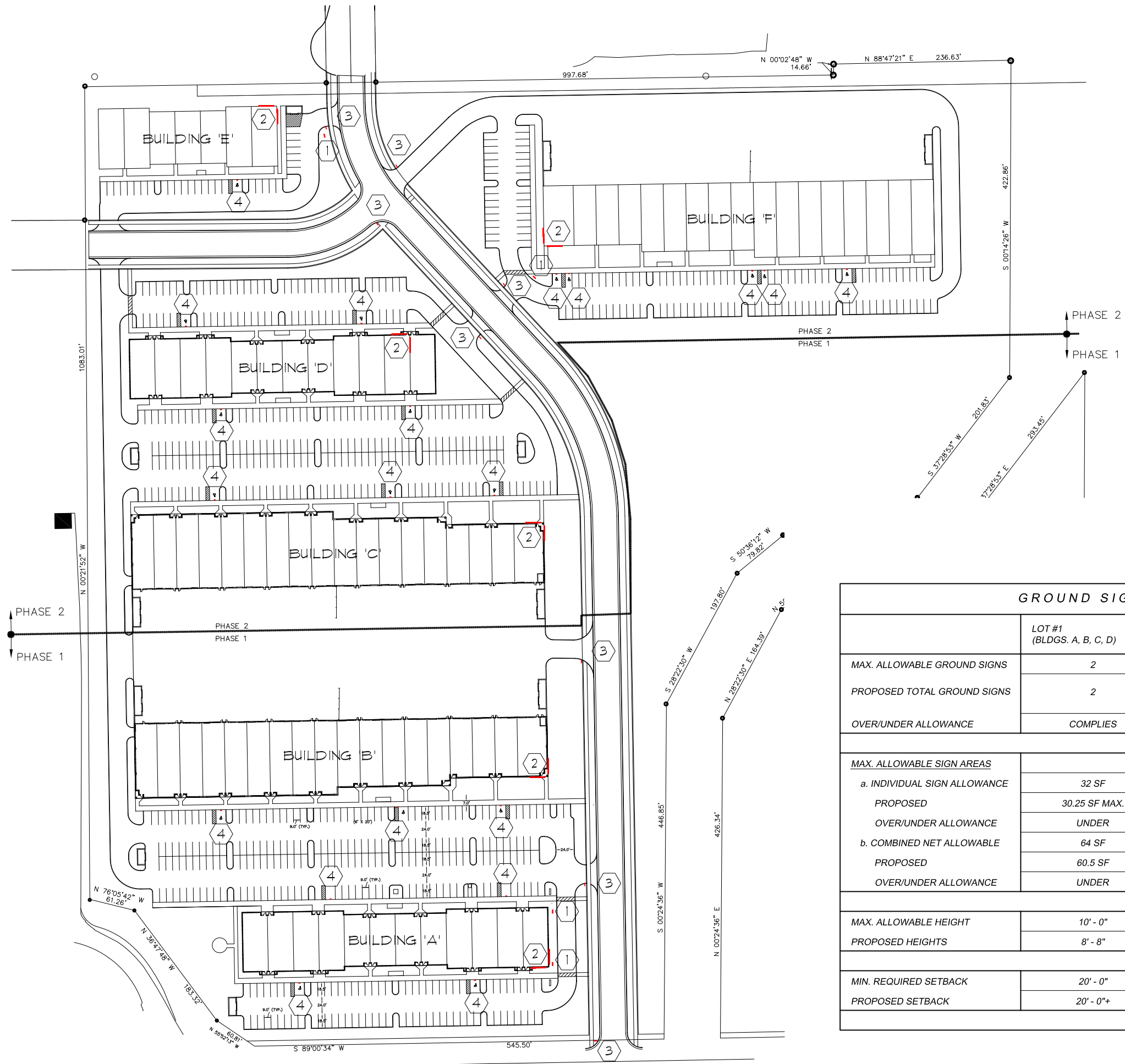

GROUND SIGN DATA SUMMARY				
	LOT #1 (BLDG. A, B, C, D)	LOT #2 (BLDG. E)	LOT #3 (BLDG. F)	NET RESULT
MAX. ALLOWABLE GROUND SIGNS	2	2	2	
PROPOSED TOTAL GROUND SIGNS	2	(1) TENANT DIRECTORY SIGN	(1) TENANT DIRECTORY SIGN	
OVER/UNDER ALLOWANCE	COMPLIES	(1) UNDER	(1) UNDER	COMPLIES
<b>MAX. ALLOWABLE SIGN AREAS</b>				
a. INDIVIDUAL SIGN ALLOWANCE	32 SF	32 SF	32 SF	COMPLIES
PROPOSED	30.25 SF MAX.	15.58 SF	28.92 SF	
OVER/UNDER ALLOWANCE	UNDER	UNDER	UNDER	
b. COMBINED NET ALLOWABLE	64 SF	64 SF	64 SF	COMPLIES
PROPOSED	60.5 SF	15.58 SF	28.92 SF	
OVER/UNDER ALLOWANCE	UNDER	UNDER	UNDER	
MAX. ALLOWABLE HEIGHT	10' - 0"	10' - 0"	10' - 0"	COMPLIES
PROPOSED HEIGHTS	8' - 8"	5' - 0"	8' - 4"	
MIN. REQUIRED SETBACK	20' - 0"	10' - 0"	20' - 0"	COMPLIES
PROPOSED SETBACK	20' - 0"+	10' - 0"	20' - 0"+	

**SITE SIGNAGE PLAN**  
 VOGES ROAD BUSINESS CENTER  
 4800 & 4950 VOGES ROAD  
 MADISON, WI

DATE:	09-26-12
PROJ. NO.:	1208138
DRAWN BY:	SPS
SHEET	

**S1.1**

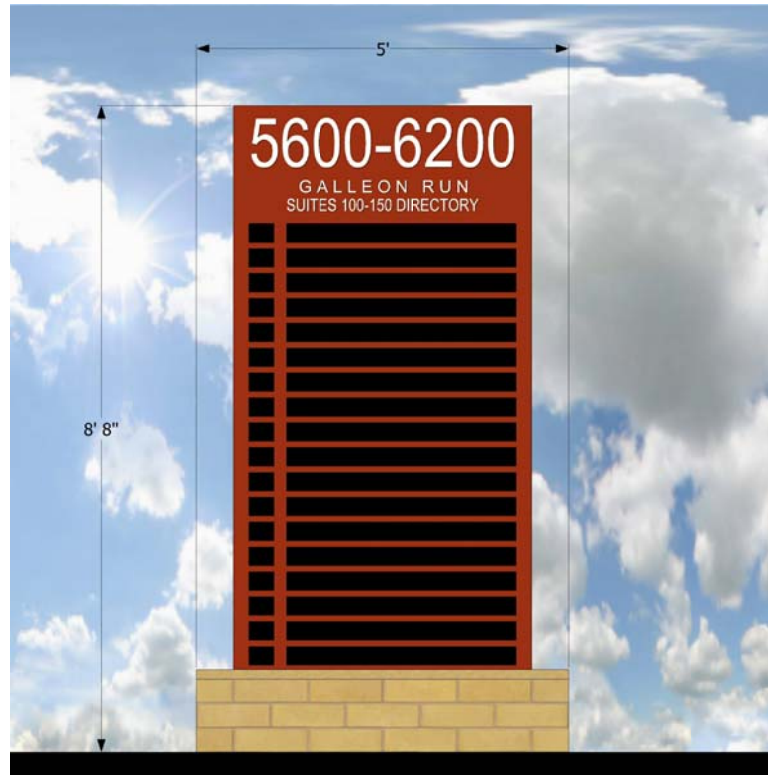

1 TENANT DIRECTORY SIGNAGE  
NOT TO SCALE

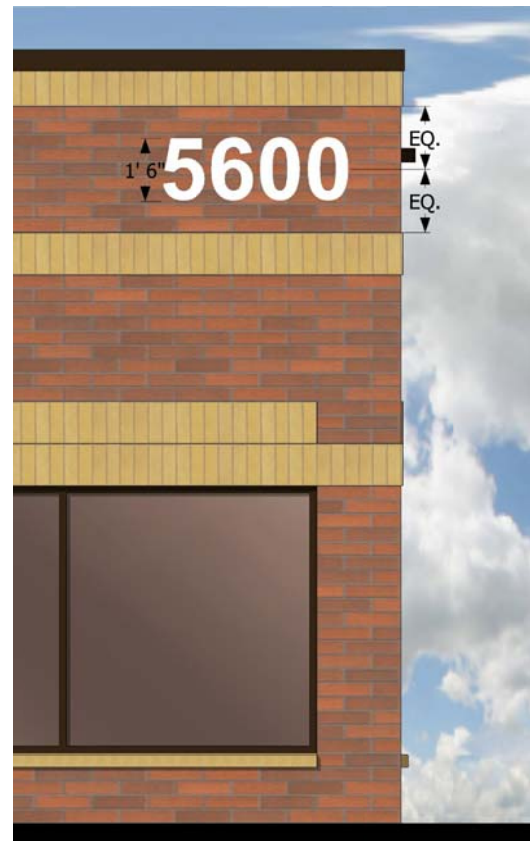

2 BUILDING ADDRESS  
NOT TO SCALE

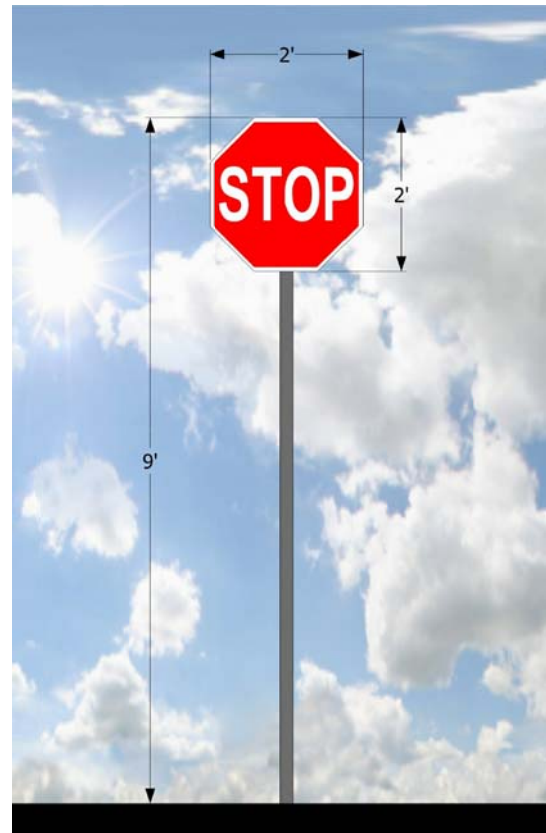

3 STOP SIGN  
NOT TO SCALE



4 ADA SIGNAGE  
NOT TO SCALE



haag müller, inc.  
Architecture • Engineering • Interiors

101 East Grand Avenue, Suite 1  
Port Washington, Wisconsin 53074  
262.268.1200 www.haagmuller.com  
COPYRIGHT 2012 © - All Rights Reserved



ST. JOHN  
PROPERTIES  
1020 JAMES DRIVE SUITE G  
HARTLAND, WISCONSIN 53029  
262.524.0100

SIGNAGE ELEVATIONS  
VOGES ROAD BUSINESS CENTER  
4800 & 4950 VOGES ROAD  
MADISON, WI

DATE: 09-26-12  
PROJ. NO.: 1208138  
DRAWN BY: SPS

SHEET  
S1.2



haag müller, inc.

Architecture • Engineering • Interiors

101 East Grand Avenue, Suite 1  
Port Washington, Wisconsin 53074  
262.268.1200 www.haagmuller.com  
COPYRIGHT 2012 © - All Rights Reserved



1020 JAMES DRIVE SUITE G  
HARTLAND, WISCONSIN 53029  
262.524.0100

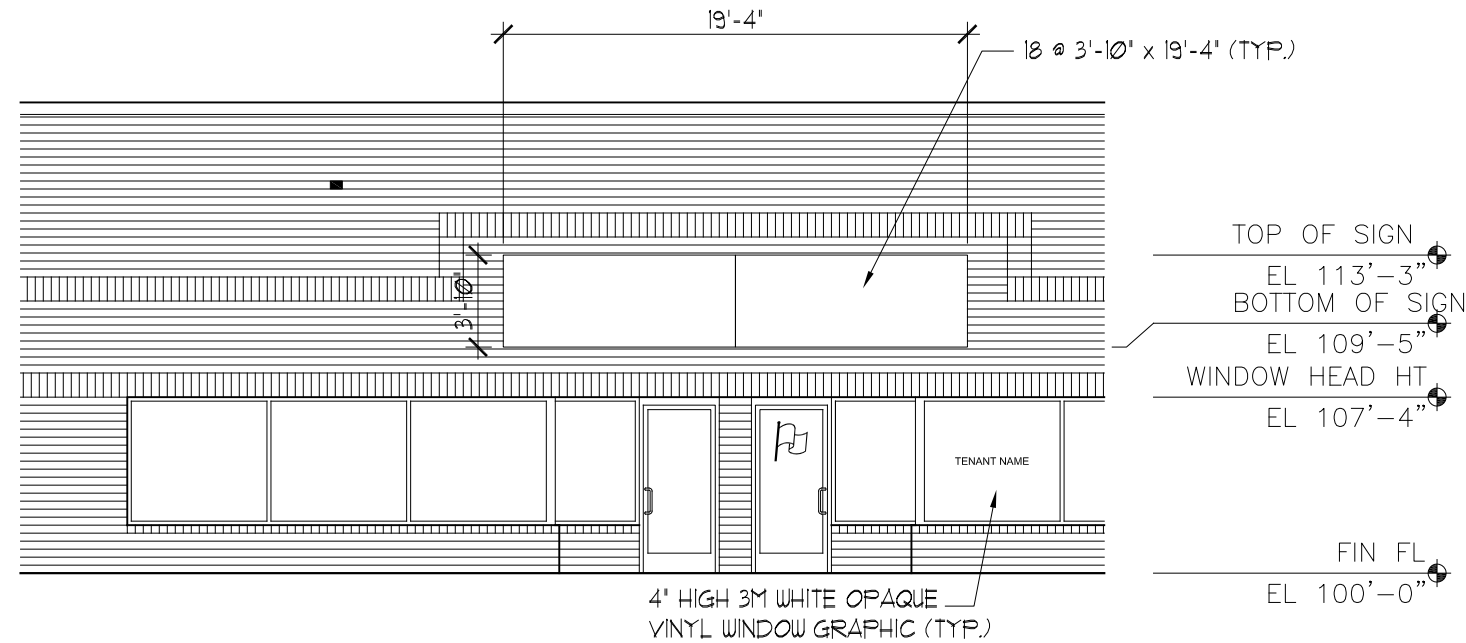

# SIGNAGE - WAREHOUSE BLDG 'B'

SCALE: 1/8" = 1' - 0"

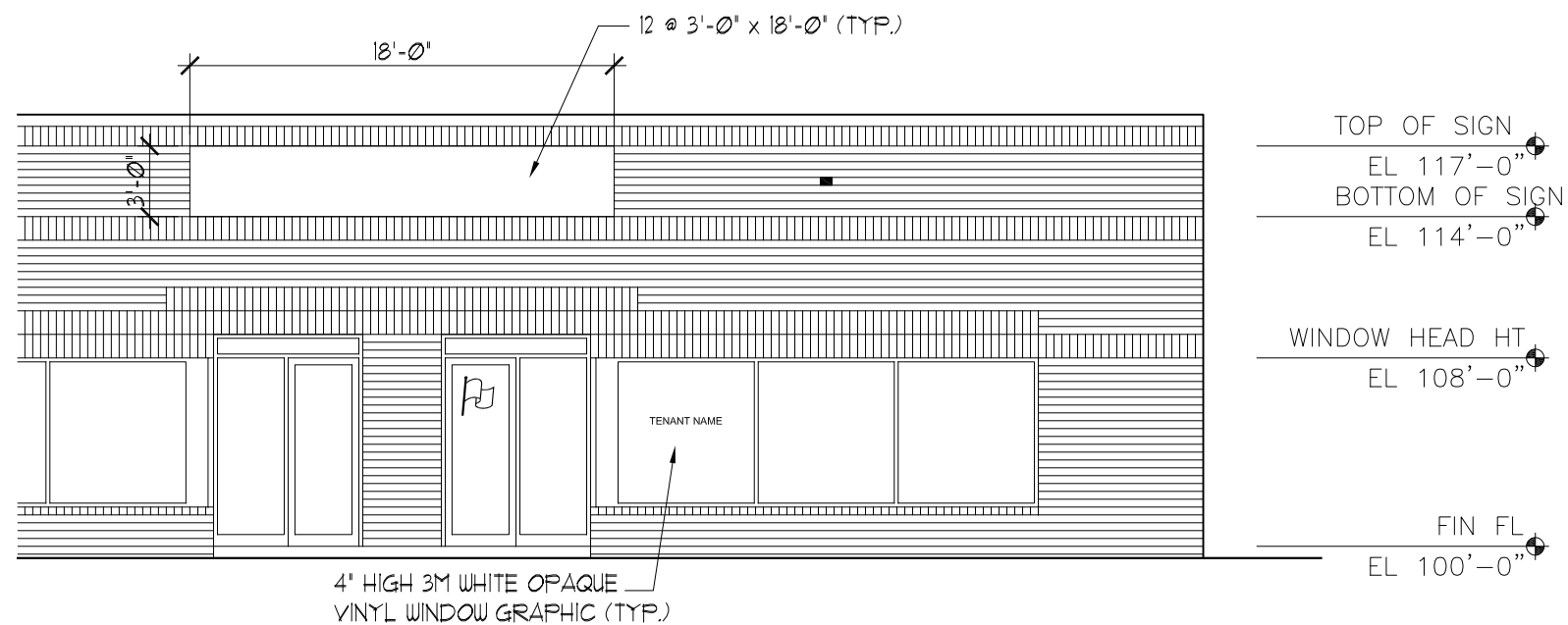

# SIGNAGE - OFFICE BLDG 'A'

SCALE: 1/8" = 1' - 0"

## BUILDING SIGN AREA SUMMARY

### OFFICE BUILDING 'A'

FACADE AREA:	7424 SF
MAXIMUM ALLOWABLE SIGN AREA:	30% OF FACADE SF (.30 x 7424 SF = 2227.2 SF)
SIGN AREA PROPOSED:	648 SF (12 SIGNS x 54 SF) = 8.7% OF FACADE

### WAREHOUSE BUILDING 'B'

FACADE AREA:	6749 SF
MAXIMUM ALLOWABLE SIGN AREA:	30% OF FACADE SF (.30 x 6749 SF = 2024.7 SF)
SIGN AREA PROPOSED:	1332 SF (18 SIGNS x 74 SF) = 19.7% OF FACADE

BUILDING SIGNAGE ELEVATIONS

VOGES ROAD BUSINESS CENTER  
4800 & 4950 VOGES ROAD  
MADISON, WI

DATE:	09-26-12
PROJ. NO.:	1208138
DRAWN BY:	JMH
SHEET	

# S1.3

# OFFICE BUILDING "A"

# WAREHOUSE BUILDING "B"

## SIGN PANEL DETAILS FOR SINGLE ENTRANCE DOORS

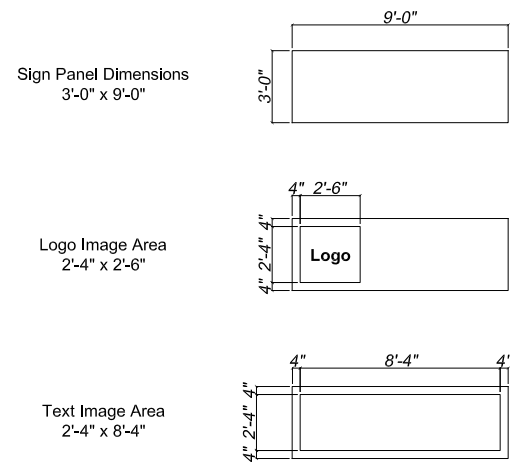

## SINGLE ENTRANCE DOOR TENANT PANEL EXAMPLES

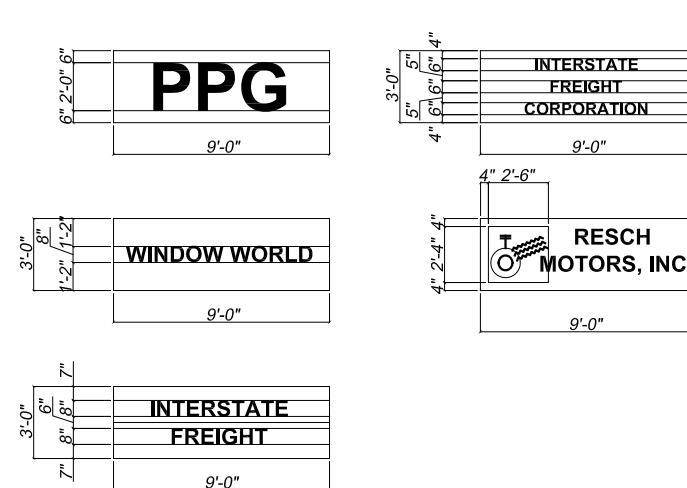

## SIGN PANEL DETAILS FOR SINGLE ENTRANCE DOORS

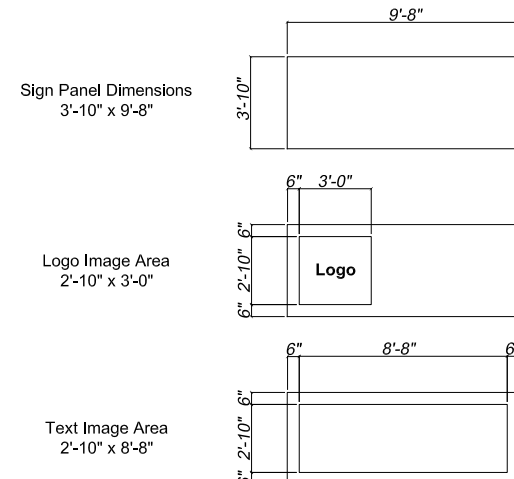

## SINGLE ENTRANCE DOOR TENANT PANEL EXAMPLES

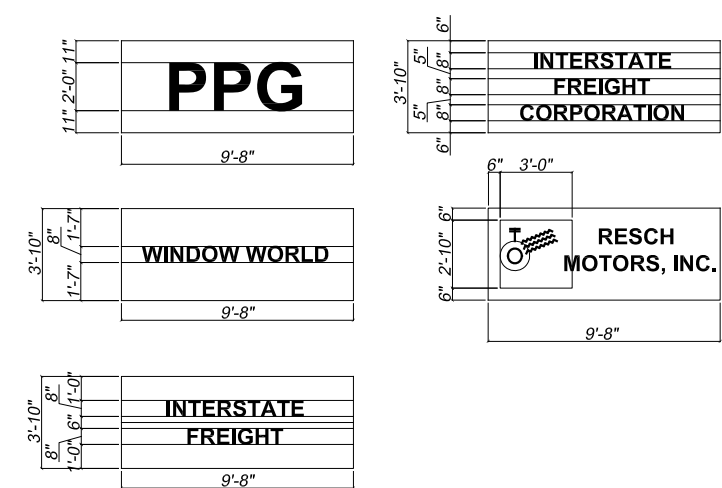

## SIGN PANEL DETAILS FOR DOUBLE ENTRANCE DOORS

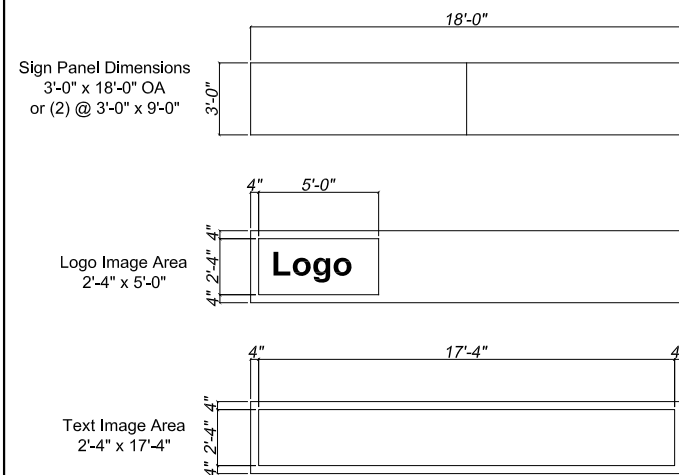

## DOUBLE ENTRANCE DOORS MULTIPLE TENANT PANEL EXAMPLES

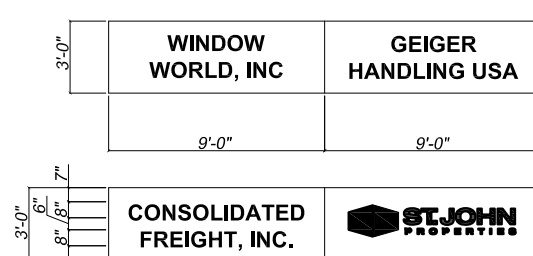

## DOUBLE ENTRANCE DOORS SINGLE TENANT PANEL EXAMPLE



## SIGN PANEL DETAILS FOR DOUBLE ENTRANCE DOORS

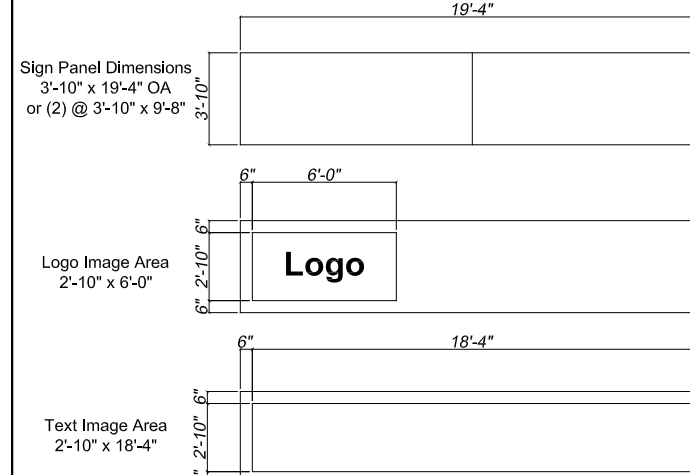

## DOUBLE ENTRANCE DOORS MULTIPLE TENANT PANEL EXAMPLES

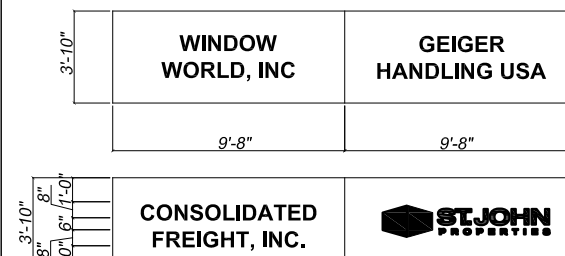

## DOUBLE ENTRANCE DOORS SINGLE TENANT PANEL EXAMPLE



## WALL SIGN PANEL STANDARDS 5600-6200 Galleon Run, Madison WI

Sign Panel Color: Bronze  
 Sign Panel Material: Aluminum Face & Components  
 Std. Font for text: Helvetica  
 Std. Font size: Height varies 6-24"  
 Std. Text Material: White Vinyl  
 Std. Logo: Tenant's Business Logo Image

Std. Logo size: Varies; see Sign Panel Details  
 Std. Logo Color: Multiple; Consistent with Tenant's Business Logo  
 Position on Building Wall: See Building Elevation Plan  
 Variations to above require Plan Commission Review/Approval based on tenant's proposed sign submittal.



haag müller, inc.  
 Architecture • Engineering • Interiors

101 East Grand Avenue, Suite 1  
 Port Washington, Wisconsin 53074  
 262.268.1200 www.haagmuller.com  
 COPYRIGHT 2012 © - All Rights Reserved



1020 JAMES DRIVE SUITE G  
 HARTLAND, WISCONSIN 53029  
 262.524.0100

SIGNAGE DIAGRAM - BUILDING "A" & "B"  
 VOGES ROAD BUSINESS CENTER  
 4800 & 4950 VOGES ROAD  
 MADISON, WI

DATE: 09-26-12  
 PROJ. NO: 1208138  
 DRAWN BY: SPS

SHEET

S1.4



haag müller, inc.

Architecture • Engineering • Interiors

101 East Grand Avenue, Suite 1  
Port Washington, Wisconsin 53074  
262.268.1200 www.haagmuller.com  
COPYRIGHT 2012 © - All Rights Reserved



1020 JAMES DRIVE SUITE G  
HARTLAND, WISCONSIN 53029  
262.524.0100



NEIGHBORHOOD PHOTO KEY PLAN  
VOGES ROAD BUSINESS CENTER  
4800 & 4950 VOGES ROAD  
MADISON, WI

# SITE AERIAL PHOTO

DATE:	09-26-12
PROJ. NO:	1208138
DRAWN BY:	JMH
SHEET	

P1.1



Ⓓ 5011 VOGES RD. - TEMPERATURE SYSTEMS, INC.



Ⓑ 4805 VOGES RD. - REDLINE WATERSPORTS



Ⓒ 4811 VOGES RD. - HEARTLAND LITHO



Ⓐ 4801 VOGES RD. - TRANE



haag müller, inc.

Architecture • Engineering • Interiors

101 East Grand Avenue, Suite 1  
Port Washington, Wisconsin 53074  
262.268.1200 www.haagmuller.com  
COPYRIGHT 2012 © - All Rights Reserved



1020 JAMES DRIVE SUITE G  
HARTLAND, WISCONSIN 53029  
262.524.0100

NEIGHBORHOOD PHOTOS

VOGES ROAD BUSINESS CENTER  
4800 & 4950 VOGES ROAD  
MADISON, WI

DATE:	09-26-12
PROJ. NO.:	1208138
DRAWN BY:	JMH

SHEET

P1.2



Ⓜ 3717 S. DUTCH MILL RD. - TOBY'S SUPPER CLUB



Ⓧ 5034 VOGES RD. - UNION TRANSFER & STORAGE, INC.



Ⓝ 4801 TRADEWINDS PARKWAY. - BAUER & RAETHER BUILDERS



Ⓧ 5014 VOGES RD. - GBS



haag müller, inc.

Architecture • Engineering • Interiors

101 East Grand Avenue, Suite 1  
Port Washington, Wisconsin 53074  
262.268.1200 www.haagmuller.com  
COPYRIGHT 2012 © - All Rights Reserved



ST. JOHN  
PROPERTIES  
1020 JAMES DRIVE SUITE G  
HARTLAND, WISCONSIN 53029  
262.524.0100

NEIGHBORHOOD PHOTOS

VOGES ROAD BUSINESS CENTER  
4800 & 4950 VOGES ROAD  
MADISON, WI

DATE:	09-26-12
PROJ. NO.:	1208138
DRAWN BY:	JMH

SHEET

P1.3





L 4015 TERMINAL DR. - STETSON BUILDING PRODUCTS



J 3801 S. DUTCH MILL RD. - LA PETITE ACADEMY



K 3815 S. DUTCH MILL RD. - CROSSROADS CHURCH



I 3715 S. DUTCH MILL RD. - AUTOWORKS



haag müller, inc.  
Architecture • Engineering • Interiors

101 East Grand Avenue, Suite 1  
Port Washington, Wisconsin 53074  
262.268.1200 www.haagmuller.com  
COPYRIGHT 2012 © - All Rights Reserved



ST. JOHN  
PROPERTIES  
1020 JAMES DRIVE SUITE G  
HARTLAND, WISCONSIN 53029  
262.524.0100

NEIGHBORHOOD PHOTOS

VOGES ROAD BUSINESS CENTER  
4800 & 4950 VOGES ROAD  
MADISON, WI

DATE:	09-26-12
PROJ. NO.:	1208138
DRAWN BY:	JMH

SHEET

P1.4

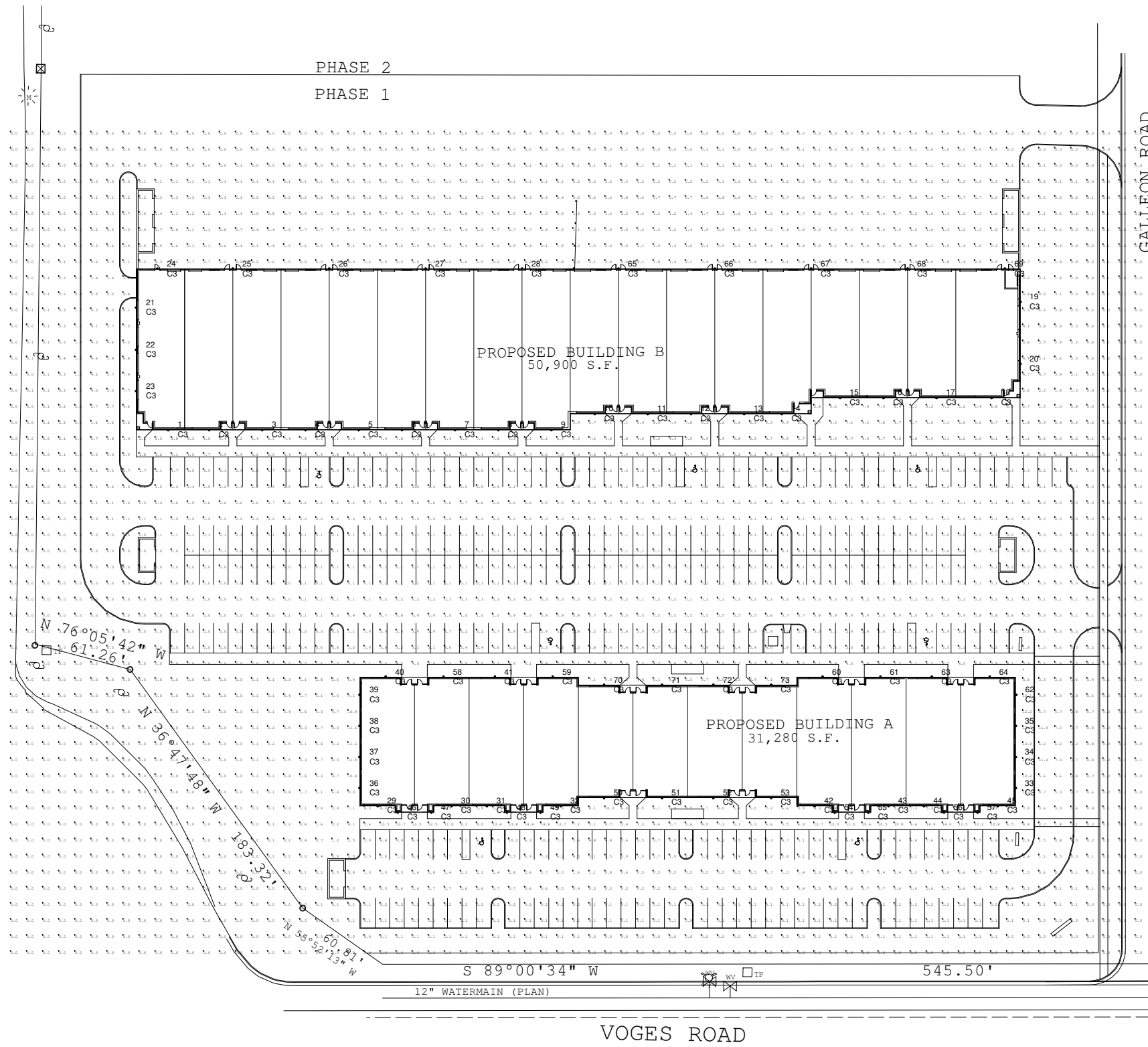

LumNo	Z	TM
1	16	0
2	16	0
3	16	0
4	16	0
5	16	0
6	16	0
7	16	0
8	16	0
9	16	0
10	16	0
11	16	0
12	16	0
13	16	0
14	16	0
15	16	0
16	16	0
17	16	0
18	16	0
19	16	0
20	16	0
21	16	0
22	16	0
23	16	0
24	16	0
25	16	0
26	16	0
27	16	0
28	16	0
29	16	0
30	16	0
31	16	0
32	16	0
33	16	0
34	16	0
35	16	0
36	16	0
37	16	0
38	16	0
39	16	0
40	16	0
41	16	0
42	16	0
43	16	0
44	16	0
45	16	0
46	16	0
47	16	0
48	16	0
49	16	0
50	16	0
51	16	0
52	16	0
53	16	0
54	16	0
55	16	0
56	16	0
57	16	0
58	16	0
59	16	0
60	16	0
61	16	0
62	16	0
63	16	0
64	16	0
65	20	0
66	20	0
67	20	0
68	20	0
69	20	0
70	16	0
71	16	0
72	16	0
73	16	0

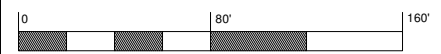

Symbol	Qty	Label	Arrangement	Lumens/Lamp	LLF	Total Watts	Description
●	73	C3	SINGLE	14000	0.750	13870	MGWC0615-M 150W PSMH

Label	Avg	Max	Min	Avg/Min	Max/Min
GRADE	1.47	14.9	0.0	N.A.	N.A.

**RUUD LIGHTING  
DIRECT**  
9201 Washington Ave  
Racine, WI 53406  
PH: (800) 236-7000  
FX: (800) 236-7500  
www.ruudlightingdirect.com

Date: 9/10/2012 Scale: 1"=40' Layout by: ANTONIO CRIVELLO  
Project Name: VOGES ROAD CENTER - MADISON, WI Customer No: 90249  
Filename: V:\CommonAppEng\OUT\120910SJ1TGC.AGI  
Footcandles calculated at grade using mean lumen values  
Illumination results shown on this lighting design are based on project parameters provided to Ruud Lighting used in conjunction with luminaire test procedures conducted under laboratory conditions. Actual project conditions differing from these design parameters may affect field results. The customer is responsible for verifying dimensional accuracy along with compliance with any applicable electrical, lighting, or energy code.

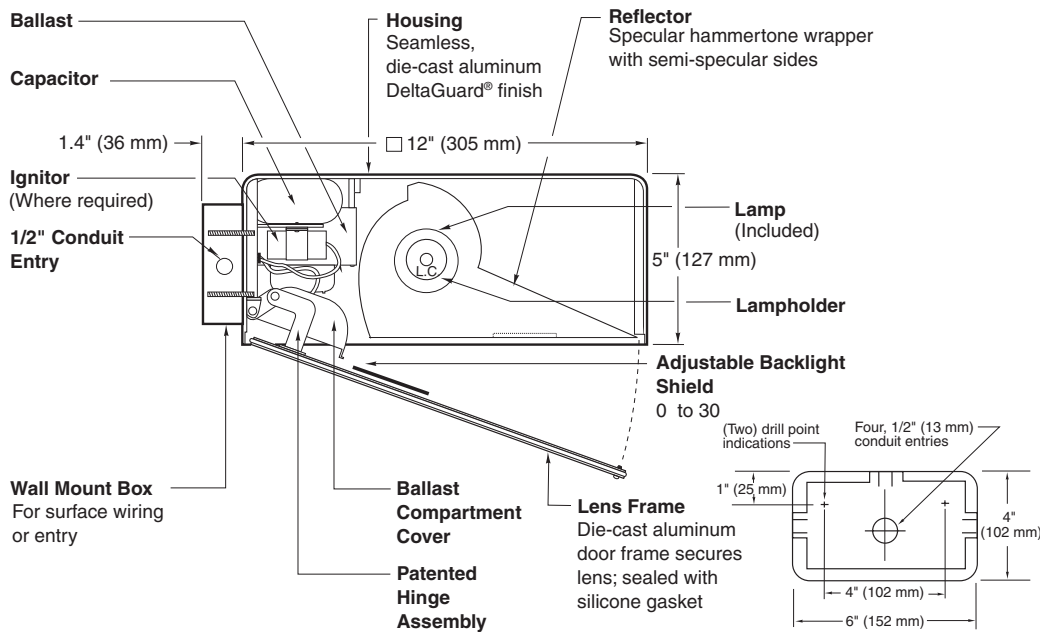

SPEC #	WATTAGE	CATALOG #
<b>PULSE START METAL HALIDE</b>		
	50W PSMH	MACW405-(a)(b)
	70W PSMH	MACW407-(a)(b)
	100W PSMH	MACW410-(a)(b)
	150W PSMH	MACW615-(a)(b)
<b>HIGH PRESSURE SODIUM</b>		
	50W HPS	MACW505-(a)(b)
	70W HPS	MACW507-(a)(b)
	100W HPS	MACW510-(a)(b)
	150W HPS	MACW515-(a)(b)

Specify (a) Voltage & (b) Options.

(a) VOLTAGE SUFFIX KEY	
<b>D</b>	120/277V (Standard: 50W HPS)
<b>M</b>	120/208/240/277V (Standard: PSMH; 70 – 150W HPS)
<b>T</b>	120/277/347V (Canada Only) (Standard: 70 – 150W PSMH; 70 – 150W HPS)
<b>1</b>	120V
<b>2</b>	277V
<b>27</b>	277V Reactor (150W PSMH Only)
<b>3</b>	208V
<b>4</b>	240V
<b>5</b>	480V (70 – 150W PSMH; 70-150W HPS)
<b>6</b>	347V (Canada Only)

For voltage availability outside the US and Canada, see Bulletin TD-9 or contact your Ruud Lighting authorized International Distributor.

(b) OPTIONS (factory-installed)	
<b>-(a)F</b>	Fusing
<b>Q</b>	Quartz Standby (includes 100W quartz lamp) (N/A on 277V Reactor)
<b>-(a)P</b>	Button Photocell
<b>-5P</b>	External Photocell (for 480V)

Specify (a) Single Voltage — See Voltage Suffix Key

### GENERAL DESCRIPTION

60° forward throw sharp cutoff luminaire with adjustable backlight control for HID lamp, totally enclosed. Backlight shield provides precise cutoff adjustability from 0° (nadir) to 30° (house-side). Housing is seamless, die-cast aluminum. Fixture mounts to wall with a 4" (102 mm) x 6" (152 mm) x 1.4" (36 mm) cast aluminum mounting box and gasket. Two 5/16" threaded mounting rods are supplied with nuts and sealing washers to attach fixture to mounting box. Also provided are four threaded and closed 1/2" conduit entries. Lens assembly consists of rigid aluminum frame and high-impact, clear-tempered glass and backlight shield.

### ELECTRICAL

Fixture includes clear, medium-base lamp. Pulse-rated porcelain enclosed, 4kv-rated screw-shell-type lampholder. Lamp ignitor included where required. All ballast assemblies are high-power factor and use the following circuit types:

*120V Reactor*  
50 – 150W HPS

*277V Reactor*  
150W PSMH

*HX — High Reactance*  
50 – 150W PSMH; 50 – 150W HPS

*CWA — Constant Wattage Autotransformer*  
150W PSMH – 480V

### PATENT

US 4,689,729; 4,709,312

### FINISH

Exclusive Colorfast DeltaGuard® finish features an E-coat epoxy primer with medium bronze ultra-durable powder topcoat, providing excellent resistance to corrosion, ultraviolet degradation and abrasion. The finish is covered by our seven-year limited warranty.

### LABELS

ANSI lamp wattage label supplied, visible during relamping. UL Listed in US and Canada for wet locations and enclosure classified IP65 per IEC 529 and IEC 598.

### ACCESSORIES

**FWG-12** Wire Guard

**EPA RATING**

EPA 0.60 for single fixture with 0° tilt (Consult factory for EPA rating on multiple units).

Isofootcandle plots show initial footcandles at grade. (Footcandles ÷ 0.0929 = Lux)

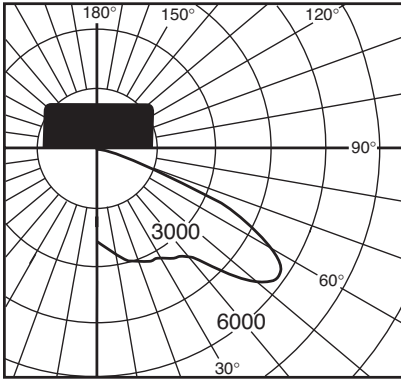

Lighting Sciences Inc.  
Certified Test Report No. LSI 14227  
Candlepower distribution curve of 150W PSMH Rectangular Area Cutoff Floodlight, with backlight shield located for backlight cutoff.

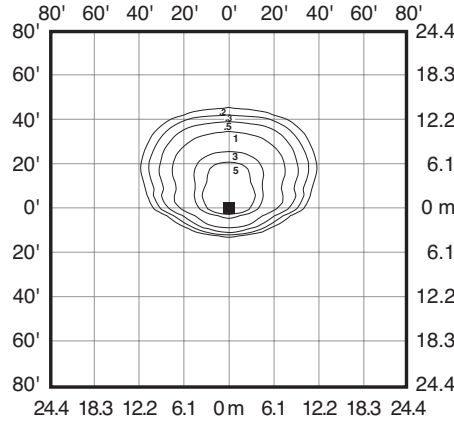

Isofootcandle plot of 150W PSMH Area Cutoff Floodlight at 15' (4.6 m) mounting height, 0° vertical tilt, with backlight shield located for backlight cutoff. (Plan view)

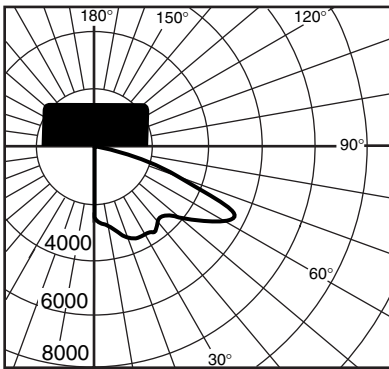

Lighting Sciences Inc.  
Certified Test Report No. LSI 11233  
Candlepower distribution curve of 150W HPS Rectangular Area Cutoff Floodlight, with backlight shield located for backlight cutoff.

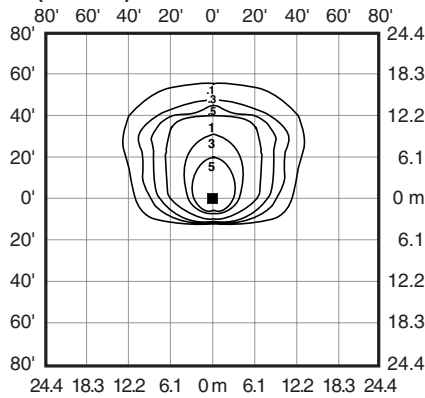

Isofootcandle plot of 150W HPS Area Cutoff Floodlight at 15' (4.6 m) mounting height, 0° vertical tilt, with backlight shield located for backlight cutoff. (Plan view)

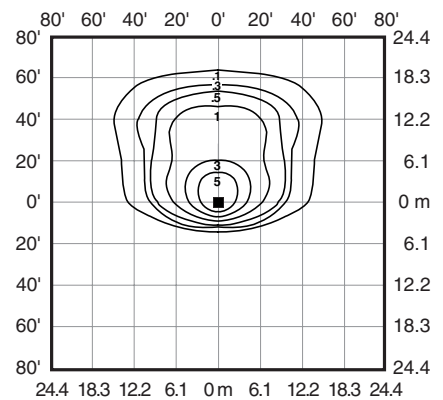

Isofootcandle plot of 150W HPS Area Cutoff Floodlight at 20' (6.1 m) mounting height, 0° vertical tilt, with backlight shield located for backlight cutoff. (Plan view)