



Location
6698 Odana Road

Project Name
Retail Redevelopment

Applicant
SJR Odana, LLC/
John Bieno – TJK Design Build

Existing Use
Former bank building

Proposed Use
Demolish bank and construct multi-tenant retail building with vehicle access service window

Public Hearing Date
Plan Commission
22 July 2013

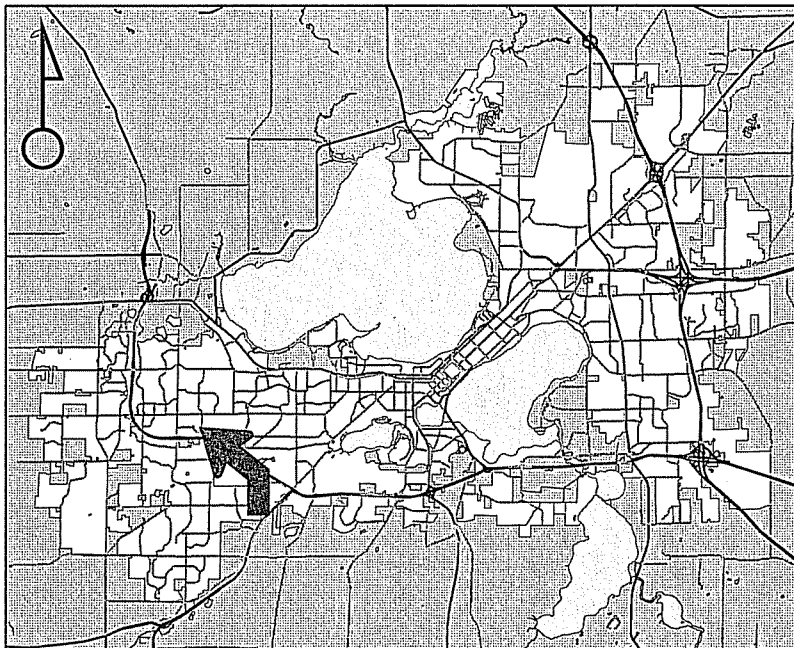

For Questions Contact: Kevin Firchow at: 267-1150 or kfirchow@cityofmadison.com or City Planning at 266-4635



Scale : 1" = 400'

City of Madison, Planning Division : RPJ : Date : 12 July 2013

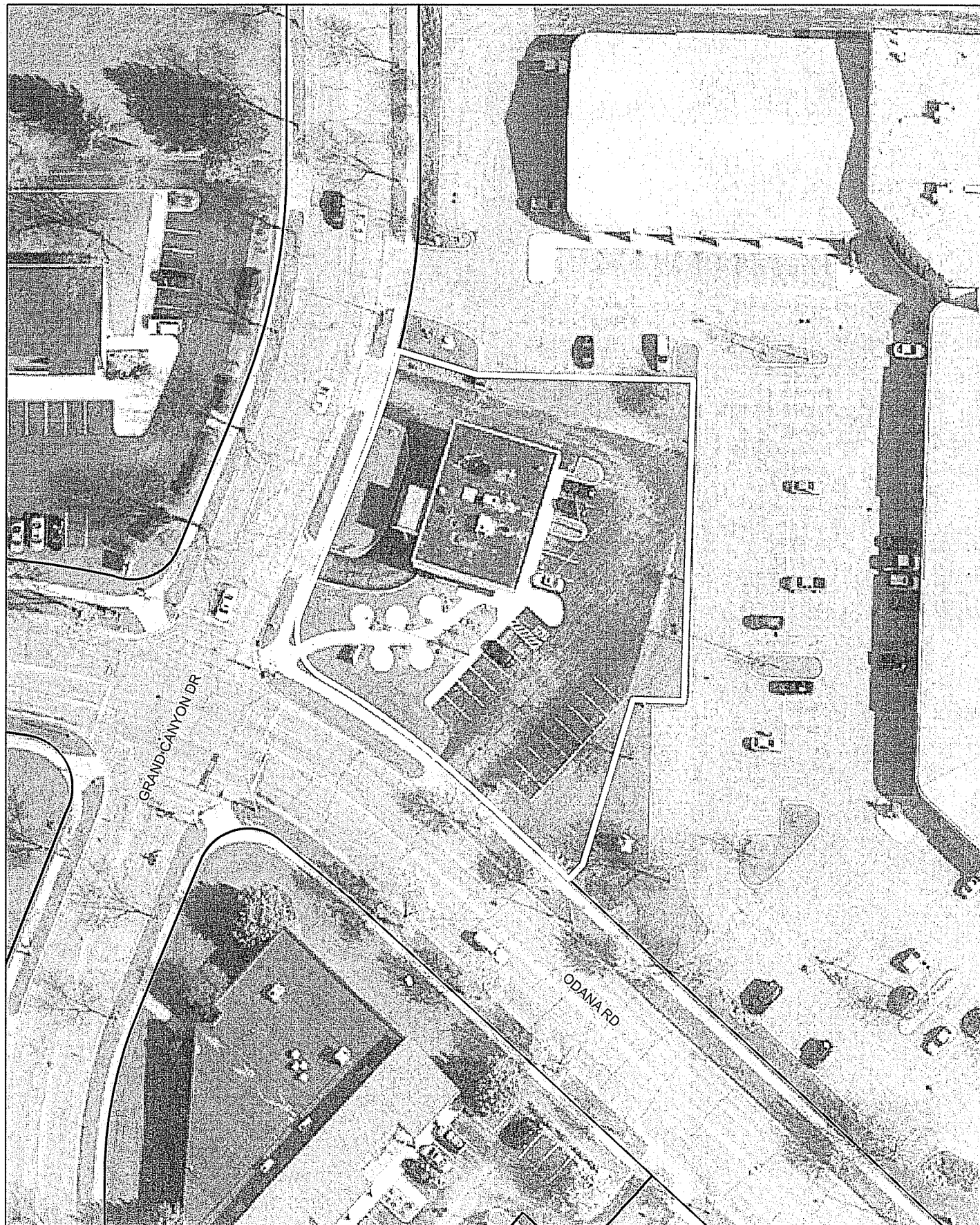



LAND USE APPLICATION

CITY OF MADISON

215 Martin Luther King Jr. Blvd; Room LL-100
PO Box 2985; Madison, Wisconsin 53701-2985
Phone: 608.266.4635 | Facsimile: 608.267.8739

- All Land Use Applications should be filed with the Zoning Administrator at the above address.
- The following information is required for all applications for Plan Commission review except subdivisions or land divisions, which should be filed using the Subdivision Application.
- This form may also be completed online at:
www.cityofmadison.com/developmentcenter/landdevelopment

FOR OFFICE USE ONLY:	
Amt. Paid <u>\$1650-</u>	Receipt No. <u>142567</u>
Date Received <u>5/8/13</u>	
Received By <u>SJK</u>	
Parcel No. <u>0706-252-0609-2</u>	
Aldermanic District <u>19 Mark Clear</u>	
Zoning District <u>CC</u>	
Special Requirements <u>OK</u>	
Review Required By:	
<input type="checkbox"/> Urban Design Commission	<input checked="" type="checkbox"/> Plan Commission
<input type="checkbox"/> Common Council	<input type="checkbox"/> Other: _____

Form Effective: February 21, 2013

1. Project Address: 4098 ODANA ROAD
Project Title (if any): _____

2. This is an application for (Check all that apply to your Land Use Application):

- Zoning Map Amendment from _____ to _____
- Major Amendment to Approved PD-GDP Zoning Major Amendment to Approved PD-SIP Zoning
- Review of Alteration to Planned Development (By Plan Commission)
- Conditional Use, or Major Alteration to an Approved Conditional Use
- Demolition Permit
- Other Requests: _____

3. Applicant, Agent & Property Owner Information:

Applicant Name: JOHN BIENO Company: TJK DESIGN BUILD
 Street Address: 1024 WEST MAIN ST City/State: MADISON, WI Zip: 53703
 Telephone: (608) 2571090 Fax: (608) 2571092 Email: JBIENO@TJK-DESIGN-BUILD.COM

Project Contact Person: SAME AS ABOVE Company: _____
 Street Address: _____ City/State: _____ Zip: _____
 Telephone: () _____ Fax: () _____ Email: _____

Property Owner (if not applicant): SJR ODANA, LLC
 Street Address: 4518 MONONA DRIVE City/State: MADISON, WI Zip: 53710

4. Project Information:

Provide a brief description of the project and all proposed uses of the site: MULTI TENANT RETAIL BUILDING WITH PRODUCT PICK-UP/DROP-OFF WINDOW
 Development Schedule: Commencement JULY 2013 Completion DECEMBER 2013

5. Required Submittal Information

All Land Use applications are required to include the following:

Project Plans including:*

- Site Plans (fully dimensioned plans depicting project details including all lot lines and property setbacks to buildings; demolished/proposed/altered buildings; parking stalls, driveways, sidewalks, location of existing/proposed signage; HVAC/Utility location and screening details; useable open space; and other physical improvements on a property)
- Grading and Utility Plans (existing and proposed)
- Landscape Plan (including planting schedule depicting species name and planting size)
- Building Elevation Drawings (fully dimensioned drawings for all building sides, labeling primary exterior materials)
- Floor Plans (fully dimensioned plans including interior wall and room location)

Provide collated project plan sets as follows:

- **Seven (7) copies** of a full-sized plan set drawn to a scale of 1 inch = 20 feet (folded or rolled and stapled)
- **Twenty Five (25) copies** of the plan set reduced to fit onto 11 X 17-inch paper (folded and stapled)
- **One (1) copy** of the plan set reduced to fit onto 8 ½ X 11-inch paper

* For projects requiring review by the **Urban Design Commission**, provide **Fourteen (14) additional 11x17 copies** of the plan set. In addition to the above information, all plan sets should also include: 1) Colored elevation drawings with shadow lines and a list of exterior building materials/colors; 2) Existing/proposed lighting with photometric plan & fixture cutsheet; and 3) Contextual site plan information including photographs and layout of adjacent buildings and structures. The applicant shall bring samples of exterior building materials and color scheme to the Urban Design Commission meeting.

Letter of Intent: Provide one (1) Copy per Plan Set describing this application in detail including, but not limited to:

- | | | |
|---|---|--|
| • Project Team | • Building Square Footage | • Value of Land |
| • Existing Conditions | • Number of Dwelling Units | • Estimated Project Cost |
| • Project Schedule | • Auto and Bike Parking Stalls | • Number of Construction & Full-Time Equivalent Jobs Created |
| • Proposed Uses (and ft ² of each) | • Lot Coverage & Usable Open Space Calculations | • Public Subsidy Requested |
| • Hours of Operation | | |

Filing Fee: Refer to the Land Use Application Information & Fee Schedule. Make checks payable to: *City Treasurer*.

Electronic Submittal: All applicants are required to submit copies of all items submitted in hard copy with their application as Adobe Acrobat PDF files on a non-returnable CD to be included with their application materials, or by e-mail to pcapplications@cityofmadison.com.

Additional Information may be required, depending on application. Refer to the Supplemental Submittal Requirements.

6. Applicant Declarations

Pre-application Notification: The Zoning Code requires that the applicant notify the district alder and any nearby neighborhood and business associations in writing no later than 30 days prior to FILING this request. List the alderperson, neighborhood association(s), and business association(s) AND the dates you sent the notices:

MARY CLEAR APRIL 8, 2013 (VIA EMAIL) NO NEIGHBORHOOD ASSOC.

→ If a waiver has been granted to this requirement, please attach any correspondence to this effect to this form.

Pre-application Meeting with Staff: Prior to preparation of this application, the applicant is required to discuss the proposed development and review process with Zoning and Planning Division staff; note staff persons and date.

Planning Staff: KEVIN FIRCHON Date: 4.18.13 Zoning Staff: PAT ANDERSON Date: 4.18.13

The applicant attests that this form is accurately completed and all required materials are submitted:

Name of Applicant JOHN BIENO Relationship to Property: AGENT / ARCHITECT

Authorizing Signature of Property Owner [Signature] Date 5.8.13

May 8, 2013

Department of Planning & Development
City of Madison
215 Martin Luther King Jr. Blvd
PO Box 2985
Madison WI 53701

RE: **Letter of Intent**
6698 Odana Road
Madison WI

To Whom It May Concern:

The following is submitted together with the plans, application and zoning text for staff, Plan Commission and Common Council consideration of approval.

Organizational structure:

Owner: SJR Odana, LLC
4518 Monona Drive
Madison WI 53716
608-222-6060
608-222-6546 fax
Contact: Richard Klink

Architect: TJK Design Build Inc
634 West Main Street
Madison WI 53703
608-257-1090
608-257-1092 fax
Contact: John J Bieno
jjbien@tjkdesignbuild.com

Engineer: JSD Professional Services Inc.
161 Horizon Dr., Suite 101
Verona, WI 53593
608-848-5060
608-848-2255 fax
Contact: Wade Wyse, P.E.

Landscape Design: Richard Slayton, ASLA

Introduction:

The site is located on the North East corner of the intersection of Grand Canyon Drive and Odana Road. The site is approximately 30,232 SF in size and the former branch location for a bank with a drive-up. It is under the control of a single developer. The property has busy roads on two sides. On the other two sides of the property are an established retail facility. The developments that surround this lot has been established for approximately 20 – 30 years. This lot has covenants put on it by Park Town Development.

Deconstruction:

This proposed development envisions the deconstruction of the existing branch facility as well as the drive-thru. This would also include the associated sidewalk and paved areas. Inspections of these properties have been made by the development team. It's been concluded that the structures are beyond the capacity of any reasonable rehabilitation for our type of use. Additional reports on the structures existing condition will be prepared for distribution to the staff and Plan Commission. The developer will contract to prepare a recycling and reuse plan for the building and the components and materials will be handled appropriately. Although the zoning code clearly encourages the preservation of existing structures, the zoning codes purpose also includes promoting the general welfare of the City, encouraging the most appropriate land uses and conserving and enhancing the taxable value of lands and buildings. We believe that the Plan Commission can determine that the demolition standards are met.

Project Description:

The site under consideration is located along the busy thoroughfare on the West Side of Madison. The intersection at Grand Canyon Drive and Odana Road is a lighted intersection and is surrounded by projects ranging from large retail developments to small branch bank facilities, retail facilities, restaurants, car dealerships and hotels. We are proposing to remove the existing branch bank and drive-thru facility on this property and replace it with a four sided multi-tenant slab on grade development with a product pick-up window. The building has been pushed as close to the intersection as the covenants will allow. However, this is not compliant with the existing zoning requirements for this property. Parking will be along the Eastern side of the lot behind the building which acts as a screen from the West as well as Landscaping screening and building screening from the South. Entry and exit entry into the property will be off of curb cuts on Grand Canyon Drive and Odana Road. This is a reduction from the existing three curb cuts. Bike and pedestrian access is compliant with the zoning requirements and has been integrated into the design of the facility. We have also met the zoning design standards for glazing and an entry on the main façade. Landscaping has been introduced to enhance the architecture of the building as well as offer some shading and screening of the parking lot. Accent lights have been incorporated into the façade of the building. These accent lights also offer the necessary level lighting for the sidewalk between the building and the parking lot. The parking lot itself will be lit by a single pole fixture. The accent lights will continue to the other facades as well. There is no cross access requirement between this property and the neighboring property to the North and East. The building façade will be a combination of masonry elements with a sign band of synthetic stucco. Large punched openings going down to the finished floor can be found on all four facades of the building. Window frame colors have been chosen to accent the masonry itself. Fabric awnings act as a relief for the elevations of the building as well as bringing in another complimentary color to the façade. Mechanicals will be on the roof and screened with the incorporation of a corrugated metal mechanical roof screen.

Project Schedule:

It is anticipated that construction will start in the spring of 2013 and will be completed in the fall of 2013.

Social and Economic Impact:

This development will have a positive social and economic impact. The development will potentially increase the city's tax base with minimal if any increased cost to the city. The redevelopment will provide new work opportunities while promoting pedestrian, bicycle and mass transit circulation.

Thank you for your time in reviewing our proposal.

Sincerely,

John J Bieno, AIA
TJK Design Build Inc

DESCRIPTION

The Ridgeview™ LED area roadway luminaire is the compact, efficient, economical approach to LED area lighting. A pure blend of traditional form and LED efficiency; Ridgeview provides functional, low profile design with excellent operating performance. Patent pending modular LightBAR technology delivers uniform and energy conscious illumination to parking lots and perimeter security lighting applications.

Catalog #	RDG-BOI-LEDEU	Type	A
Project	Klinka Odana	Date	
Comments		Prepared by	

SPECIFICATION FEATURES

Construction

Rugged one-piece, die-cast aluminum housing secures the thermally conductive LED panel and electrical chamber. Low profile, 3G vibration rated compact design minimizes wind load requirements. Extruded aluminum frame secured with stainless steel hardware confines the LightBAR panel to the thermally conductive housing. The unique glide bracket LightBAR panel allows for easy access to the electrical chamber.

Optics

Choice of thirteen (13) patented, high efficiency AccuLED Optics™ manufactured from injection-molded acrylic. Optics are precisely designed to shape the distribution maximizing efficiency and application spacing. AccuLED optics create consistent distributions with the scalability to

meet customized application requirements. Offered standard in 4000°K (+/- 275K) CCT and nominal 70 CRI.

Electrical

LED drivers are hard mounted to die-cast aluminum back casting for optimal heat sinking and operation efficiency. 120-277V 50/60HZ, 347V 60HZ, 480V 50/60 HZ operation. Shipped standard with Cooper Lighting proprietary circuit module designed to withstand 10kV of transient line surge. 60,000 hour life with >70% lumen maintenance. The Ridgeview LED luminaire is suitable for low temperature operation down to -30C. LightBARs feature IP66 enclosure rating.

Mounting

Cast aluminum 6" arm includes bolt guides allowing for easy

position of the fixture during installation to pole. Standard single carton packaging of housing, square pole arm and round pole adapter provide contractor friendly installation. Wall mount models feature a cast aluminum arm that is directly mounted to a 4" supplied wall plate secured with set screws.

Finish

Components finished in a 5 stage Super TGIC polyester powder coat paint, 2.5 mil nominal thickness for superior protection against fade and wear. Standard colors bronze, black, grey, white, dark platinum and graphite metallic. RAL and custom color matches available.

Warranty

Ridgeview features a five-year limited warranty.

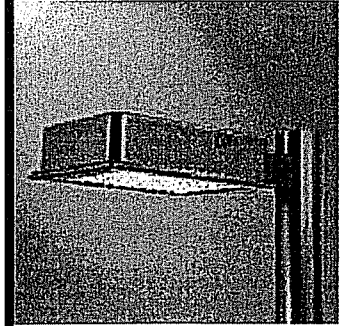

RDG RIDGEVIEW AREA/ROADWAY

1 - 4 LightBARs
Solid State LED

AREA LUMINAIRE

DIMENSIONS (SITE)

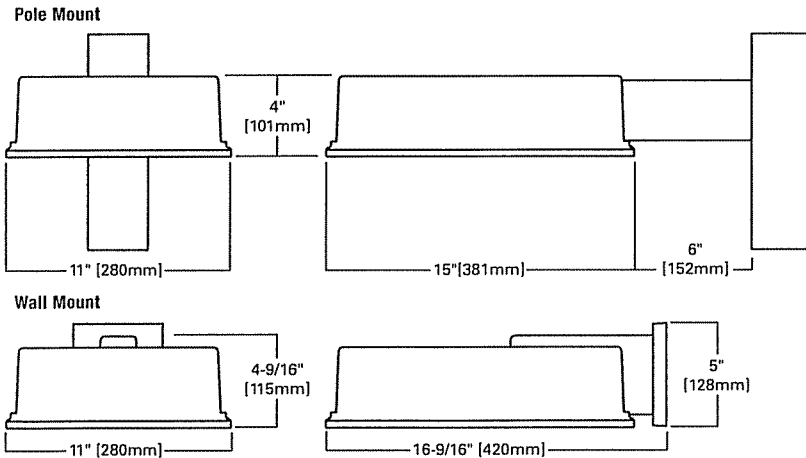

DRILLING PATTERN (SITE)

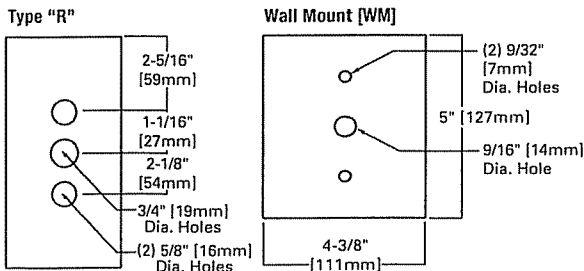

CERTIFICATIONS

UL/cUL Listed
ISO 9001
IP66 LightBARs
3G Vibration Tested
ARRA Compliant

ENERGY DATA

Electronic LED Driver
>0.9 Power Factor
<20% Total Harmonic Distortion
120-277V/50 & 60hz, 347V/60hz,
480V/60hz
-30°C Minimum Temperature
40°C Ambient Temperature Rating

EPA

Effective Projected Area: (Sq. Ft.)
Without Arm: 0.48
With Arm: 0.67

SHIPPING DATA

Approximate Net Weight:
12.5 lbs (5.8 kgs.)

Number of LightBARs	DISTRIBUTION														
	Power [Watts]	Current @ 120V [A]	Current @ 277V [A]	T2A	T3A	T3S	T4S	SL2	SL3	SL4	5MQ	5WQ	5XQ	RWQ	SLR/SLL
7 LED LIGHTBAR															
C01	27	0.23	0.13	1,886	1,858	1,796	1,842	1,869	1,895	1,842	1,959	1,929	1,965	1,866	1,742
C02	54	0.46	0.21	3,743	3,687	3,564	3,655	3,708	3,761	3,655	3,886	3,827	3,899	3,702	3,457
C03	77	0.65	0.29	5,514	5,431	5,251	5,385	5,463	5,540	5,384	5,725	5,638	5,744	5,454	5,093
C04	101	0.86	0.37	7,334	7,224	6,984	7,163	7,266	7,369	7,161	7,615	7,499	7,640	7,254	6,774
21 LED LIGHTBAR															
B01	27	0.23	0.13	2,320	2,285	2,210	2,266	2,299	2,331	2,266	2,409	2,373	2,417	2,295	2,143
B02	51	0.43	0.20	4,604	4,534	4,384	4,496	4,561	4,625	4,495	4,780	4,707	4,796	4,554	4,252
B03	73	0.62	0.28	6,782	6,680	6,459	6,624	6,719	6,814	6,622	7,042	6,935	7,065	6,708	6,264
B04	95	0.81	0.35	9,021	8,885	8,591	8,810	8,938	9,064	8,808	9,366	9,224	9,397	8,923	8,332

LUMEN MULTIPLIER

Ambient Temperature	Lumen Multiplier
10°C	1.04
15°C	1.03
25°C	1.00
40°C	0.96
50°C	0.92

ORDERING INFORMATION

SAMPLE NUMBER: RDGB04LEDEUT3SBZ

RDG Product Family ¹ RDG=Ridgeview	B01 Number of LightBARs ^{2,3} B01=[1] 21 LED LightBAR B02=[2] 21 LED LightBARs B03=[3] 21 LED LightBARs B04=[4] 21 LED LightBARs C01=[1] 7 LED LightBAR C02=[2] 7 LED LightBARs C03=[3] 7 LED LightBARs C04=[4] 7 LED LightBARs	LED Lamp Type LED=Solid State Light-Emitting Diodes	E Ballast Type E=Electronic	U Voltage U=Universal (120-277V) 8=480V 9=347V	RWQ Distribution T3S=Type III Short T4S=Type IV Short T2A=Type II Area T3A=Type III Area 5MQ=Type V Square Medium 5WQ=Type V Square Wide 5XQ=Type V Square Extra Wide RWQ=Rectangular Wide SL2=Type II w/Spill Control SL3=Type III w/Spill Control SL4=Type IV w/Spill Control SLL=90 Degree Spill Light Eliminator Left SLR=90 Degree Spill Light Eliminator Right	BZ Colors ⁴ BZ=Bronze AP=Grey BK=Black WH=White DP=Dark Platinum GM=Graphite Metallic	 Options ⁴ R90=Optics Rotated Right 90 Degrees L90=Optics Rotated Left 90 Degrees 4=NEMA Photocontrol Receptacle U=UL and cUL Listed 2L=Bi-Level Switching ⁵ Capable 7060=70 CRI/6000K CCT ⁶ 8030=80 CRI/3000K CCT WM=Wall Mount Arm ⁷ P=Button Type Photocontrol ⁸ MS-LXX=Motion sensor for on/off operation ⁹ MS/X-LXX=Motion sensor for Bi-level switching ¹⁰ BBLEDCLD=UL924 Cold Battery backup (Specify Voltage) ¹¹ HA=50 degrees High Ambient Temperature Rating ¹²	 Accessories ¹³ SA1175-XX=Single Tenon Adapter for 3-1/2" O.D. Tenon SA1176-XX=2 @ 180 Degree Tenon Adapter for 3-1/2" O.D. Tenon SA1177-XX=3 @ 120 Degree Tenon Adapter for 3-1/2" O.D. Tenon SA1178-XX=4 @ 90 Degree Tenon Adapter for 3-1/2" O.D. Tenon SA1179-XX=2 @ 90 Degree Tenon Adapter for 3-1/2" O.D. Tenon SA1180-XX=2 @ 120 Degree Tenon Adapter for 3-1/2" O.D. Tenon SA1181-XX=3 @ 90 Degree Tenon Adapter for 3-1/2" O.D. Tenon SA1182-XX=Single Tenon Adapter for 2-3/8" O.D. Tenon SA1183-XX=2 @ 180 Degree Tenon Adapter for 3-1/2" O.D. Tenon SA1184-XX=3 @ 120 Degree Tenon Adapter for 2-3/8" O.D. Tenon SA1185-XX=4 @ 90 Degree Tenon Adapter for 2-3/8" O.D. Tenon SA1186-XX=2 @ 90 Degree Tenon Adapter for 2-3/8" O.D. Tenon SA1187-XX=3 @ 90 Degree Tenon Adapter for 2-3/8" O.D. Tenon SA1117-XX=Single Arm Tenon Adapter for 2-3/8" O.D. Tenon SA1118-XX=2 @ 180 Degree Tenon Adapter for 2-3/8" O.D. Tenon SA1119-XX=3 @ 120 Degree Tenon Adapter for 2-3/8" O.D. Tenon OA/RA1016=NEMA Photocontrol - Multi-Tap OA/RA1013=Photocontrol Shorting Cap OA/RA1014=120V Photocontrol OA1223=10kV Circuit Module Replacement RV/WG=Field Installed Wire Guard
--	--	--	--	---	---	--	---	---

NOTE: 1 6 inch arm and round pole adapter included with fixture.
 2 21 LED LightBAR powered at 350mA, 7 LED LightBAR powered at 1A.
 3 Lumen values based upon 4000K CCT, 350mA or 1A drive current, 25° C ambient operating temperature.
 4 Add as suffix.
 5 2L option not available in 347V or 480V. Low-level output varies with LightBAR count. Requires quantity of two or more LightBars.
 6 Consult factory for lead times and lumen multiplier.
 7 Wall mount arm and mounting plate included with fixture.
 8 Specify voltage. Available in 120, 277, 208 or 240V.
 9 Sensor housed in external box mounted to the luminaire. Replace XX with mounting height in feet for proper lens selection (i.e., MS-L20). Not available with HA option. Consult factory for additional information.
 10 Motion sensor for bi-level switching. Sensor housed in external box mounted to the luminaire. Available in B02-B04 and C02-C04 configurations. Replace X with number of bars operating in low output mode and replace XX with fixture mounting height for proper lens selection (i.e., MS/3-L20). Not available with HA option. Consult factory for additional information.
 11 Specify 120v or 277V, available with B01 or C01 configurations only. 25 degrees C ambient operating temperature.
 12 HA not available with BBLEDCLD or MS-LXX or MS/X-LXX options. Limit 3 bars with HA option.
 13 Order separately/replace XX with color designation.
 DesignLights™ Consortium Qualified. Refer to www.designlights.org Qualified Products List under Family Models for details.

OPTIC ORIENTATION

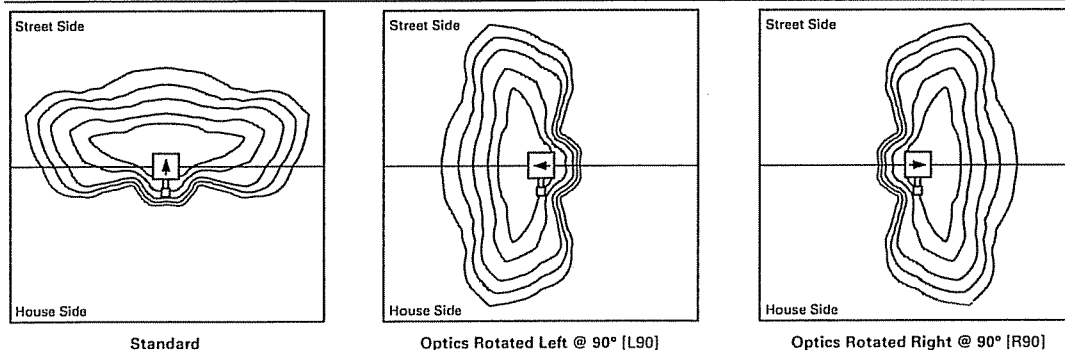

DESCRIPTION

The IMPACT Elite family of cutoff wall luminaires is the ideal complement to site design. Incorporating modular LightBAR™ technology, Impact Elite provides outstanding uniformity and energy-conscious illumination. Combined with a rugged construction, the Impact Elite is the ideal facade and security luminaire for zones surrounding schools, office complexes, apartments, and recreational facilities. UL/cUL listed for wet locations.

Catalog #	IST-B01-LED-E1-GZW-BZ--ULG	Type	B
Project	Klinke Odana	Date	05/07/2013
Comments			
Prepared by			

SPECIFICATION FEATURES

Construction

Heavy-wall, die-cast aluminum housing and removable hinged door frame for precise tolerance control and repeatability. Hinged door inset for clean mating with housing surface and secured via two (2) captive fasteners. Optional tamper resistant Torx™ - head fasteners offer vandal resistant access to the electrical chamber.

Optics

Choice of six (6) high efficiency, patented AccuLED Optics™ manufactured from injection molded acrylic. Optics are precisely designed to shape the distribution maximizing efficiency and application spacing. BL optics offer backlight control to decrease wall brightness while the optional uplight glow provides soft illumination to highlight architectural surfaces. Offered

standard in 4000°K (+/- 275K) CCT and nominal 70 CRI.

Electrical

LED drivers mount to die-cast aluminum back casting for optimal heat sinking and operation efficiency. Impact Elite Wall Series LED operates from 120-277V 50/60Hz, 347V 60Hz or 480V 60Hz. Shipped standard with Cooper Lighting proprietary circuit module designed to withstand 10kV of transient line surge. 90% lumen maintenance expected at 60,000 hours. The Impact Elite Wall Series LED luminaire is suitable for operation in -40°C to 40°C ambient environments. LightBARS™ feature an IP66 enclosure rating. Optional occupancy sensor with backbox is available.

Mounting

Gasketed and zinc plated rigid steel

mounting attachment fits directly to 4" J-box or wall with the Impact Elite "Hook-N-Lock" mechanism for quick installation. Secured with two (2) captive corrosion resistant black oxide coated allen head set screws concealed but accessible from bottom of fixture.

Finish

Cast components finished in a 5 stage super durable TGIC polyester powder coat paint, 2.5 mil nominal thickness for superior protection against fade and wear. Standard colors include black, bronze, grey, white, dark platinum, and graphite metallic. RAL and custom color matches available. Consult the McGraw-Edison Architectural Colors brochure for the complete selection.

Warranty

Five-year warranty.

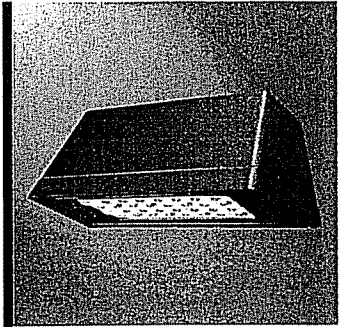

IST IMPACT ELITE LED TRAPEZOID

1 - 2 LightBARS
Solid State LED

WALL MOUNT LUMINAIRE

STANDARD DIMENSIONS

Trapezoid

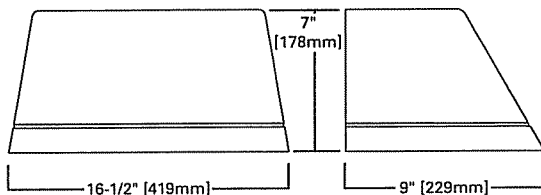

HOOK-N-LOCK MOUNTING

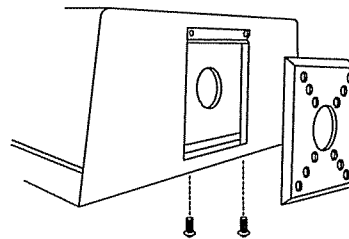

STANDARD DIMENSIONS WITH BACK BOX

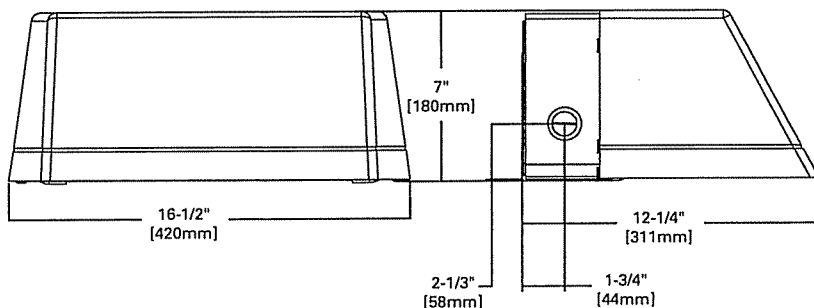

DESIGNLIGHTS
CONSORTIUM

CERTIFICATION DATA

UL/cUL Listed
LM79 / LM80 Compliant
IP66 LightBARS
ARRA Compliant
ISO 9001
DLC Qualified

ENERGY DATA

Electronic LED Driver
>0.9 Power Factor
<20% Total Harmonic Distortion
120-277V/50 & 60hz, 347V/60hz,
480V/60hz
-40°C Minimum Temperature
40°C Ambient Temperature Rating

SHIPPING DATA

Approximate Net Weight:
18 lbs. (8 kgs.)

POWER AND LUMENS BY BAR COUNT

LUMEN MULTIPLIER

Number of LightBARs	DISTRIBUTION							
	Power [Watts]	Current @ 120V [A]	Current @ 277V [A]	BL2	BL3	BL4	GZW	SLR/SLL
7 LED LIGHTBAR								
C01	27	0.23	0.13	1,770	1,625	1,720	1,725	1,571
C02	54	0.46	0.21	3,540	3,249	3,440	3,450	3,142
21 LED LIGHTBAR								
B01	27	0.23	0.13	2,177	1,998	2,115	2,122	1,932
B02	51	0.43	0.20	4,354	3,996	4,231	4,244	3,865

Ambient Temperature	Lumen Multiplier
10°C	1.04
15°C	1.03
25°C	1.00
40°C	0.96

ORDERING INFORMATION

IST-B01-LED-E1-GZW-BZ-ULG

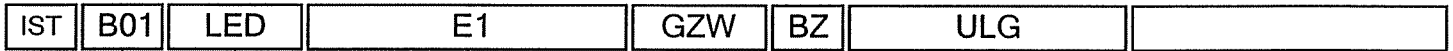

Product Family¹
IST= Impact Elite Small Trapezoid

Number of^{2,3}
LightBARs
B01= [1] 21 LED LightBAR
B02= [2] 21 LED LightBARs
C01= [1] 7 LED LightBAR
C02= [2] 7 LED LightBARs

Lamp Type
LED= Solid State Light Emitting Diodes
Voltage
E1=Electronic 120-277V
347=347V
480=480V

Distribution
GZW= Wall Grazer Wide
BL2= Type II w/ Back Light Control
BL3= Type III w/ Back Light Control
BL4= Type IV w/ Back Light Control
SLL=90 Degree Spill Light Eliminator Left
SLR=90 Degree Spill Light Eliminator Right

Finish
AP=Grey
BZ=Bronze
BK=Black
DP=Dark Platinum
GM=Graphite Metallic
WH=White

Options⁴
P= Button Type Photocontrol (120V,⁵ 208, 240, or 277V)
2L= Two Circuits⁶
TR= Tamper Resistant Fasteners
7060=70 CRI/6000K CCT⁷
8030=80 CRI/3000K CCT⁷
ULG=Uplight Glow⁸
LCF=LightBAR Cover Plate Matches Housing Finish
OSB=Occupancy sensor standard⁹ with back box matching housing finish.
BBB=Emergency LED power^{10, 11, 12} pack (UL924 listed) 0° C/32° F standard with back box matching housing finish.
CWB=Emergency LED cold^{10, 13} temperature power pack (UL924 listed) -20° C/-4° F standard with back box matching housing finish.

Accessories¹⁴
MA1254-BZ=Thruway Back Box - Impact Elite Trapezoid¹⁵
MA1253=10kV Circuit Module Replacement

- Notes: 1 DesignLights™ Consortium Qualified. Refer to www.designlights.org Qualified Products List under Family Models for details.
 2 Standard 4000K CCT and nominal 70CRI.
 3 21 LED LightBAR powered at 350mA, 7 LED LightBAR powered at 1A.
 4 Add as suffix.
 5 Must specify voltage.
 6 Only available in 2 bar (B02 or C02) configurations.
 7 Consult Factory for lead times and lumen multiplier.
 8 Provides 10% uplight in 2 bar (B02 or C02) configurations and 20% uplight in 1 bar (B01 or C01) configurations.
 9 Only available in 2 BAR (B02 or C02) configurations; street-side LightBAR will be wired to sensor. Time delay factory setting is 15 minutes.
 10 Not available with OSB.
 11 Specify 120 or 277V, (0°C) minimum temperature.
 12 Consult factory for availability.
 13 Specify 120 or 277V, (-20°C) minimum temperature.
 14 Order separately.
 15 Specify finish (color) in place of "XX".

DESCRIPTION

The IMPACT Elite family of cutoff wall luminaires is the ideal complement to site design. Incorporating modular LightBAR™ technology, Impact Elite provides outstanding uniformity and energy-conscious illumination. Combined with a rugged construction, the Impact Elite is the ideal facade and security luminaire for zones surrounding schools, office complexes, apartments, and recreational facilities. UL/cUL listed for wet locations.

Catalog #	IST-B01-LED-E1-BL3-BZ	Type	C
Project	Klinke Odana	Date	05/07/2013
Comments			
Prepared by			

SPECIFICATION FEATURES

Construction

Heavy-wall, die-cast aluminum housing and removable hinged door frame for precise tolerance control and repeatability. Hinged door inset for clean mating with housing surface and secured via two (2) captive fasteners. Optional tamper resistant Torx™ - head fasteners offer vandal resistant access to the electrical chamber.

Optics

Choice of six (6) high efficiency, patented AccuLED Optics™ manufactured from injection molded acrylic. Optics are precisely designed to shape the distribution maximizing efficiency and application spacing. BL optics offer backlight control to decrease wall brightness while the optional uplight glow provides soft illumination to highlight architectural surfaces. Offered

standard in 4000°K (+/- 275K) CCT and nominal 70 CRI.

Electrical

LED drivers mount to die-cast aluminum back casting for optimal heat sinking and operation efficiency. Impact Elite Wall Series LED operates from 120-277V 50/60Hz, 347V 60Hz or 480V 60Hz. Shipped standard with Cooper Lighting proprietary circuit module designed to withstand 10kV of transient line surge. 90% lumen maintenance expected at 60,000 hours. The Impact Elite Wall Series LED luminaire is suitable for operation in -40°C to 40°C ambient environments. LightBARS™ feature an IP66 enclosure rating. Optional occupancy sensor with backbox is available.

Mounting

Gasketed and zinc plated rigid steel

mounting attachment fits directly to 4" J-box or wall with the Impact Elite "Hook-N-Lock" mechanism for quick installation. Secured with two (2) captive corrosion resistant black oxide coated allen head set screws concealed but accessible from bottom of fixture.

Finish

Cast components finished in a 5 stage super durable TGIC polyester powder coat paint, 2.5 mil nominal thickness for superior protection against fade and wear. Standard colors include black, bronze, grey, white, dark platinum, and graphite metallic. RAL and custom color matches available. Consult the McGraw-Edison Architectural Colors brochure for the complete selection.

Warranty

Five-year warranty.

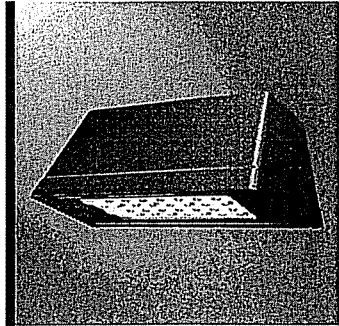

IST IMPACT ELITE LED TRAPEZOID

1 - 2 LightBARS
Solid State LED

WALL MOUNT LUMINAIRE

DESIGNLIGHTS
CONSORTIUM

STANDARD DIMENSIONS

Trapezoid

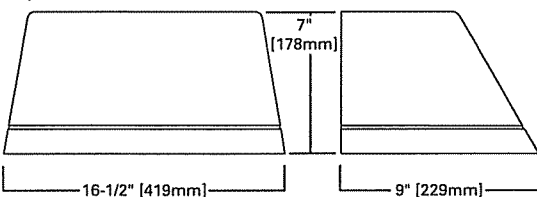

HOOK-N-LOCK MOUNTING

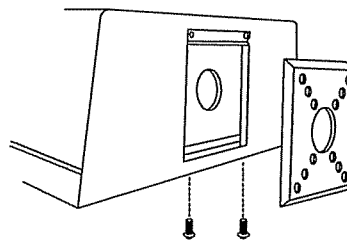

STANDARD DIMENSIONS WITH BACK BOX

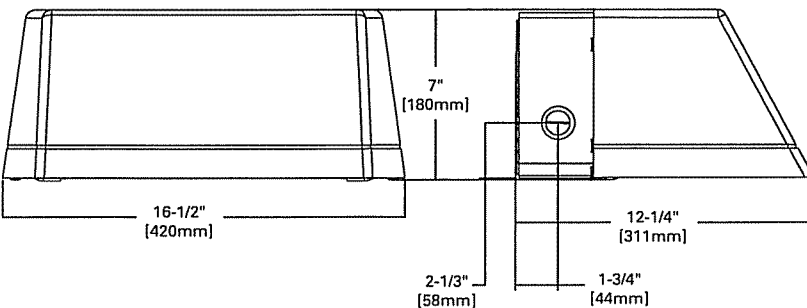

CERTIFICATION DATA

UL/cUL Listed
LM79 / LM80 Compliant
IP66 LightBARS
ARRA Compliant
ISO 9001
DLC Qualified

ENERGY DATA

Electronic LED Driver
>0.9 Power Factor
<20% Total Harmonic Distortion
120-277V/50 & 60hz, 347V/60hz,
480V/60hz
-40°C Minimum Temperature
40°C Ambient Temperature Rating

SHIPPING DATA

Approximate Net Weight:
18 lbs. (8 kgs.)

POWER AND LUMENS BY BAR COUNT

LUMEN MULTIPLIER

Number of LightBARs	DISTRIBUTION							
	Power [Watts]	Current @ 120V [A]	Current @ 277V [A]	BL2	BL3	BL4	GZW	SLR/ SLL
7 LED LIGHTBAR								
C01	27	0.23	0.13	1,770	1,625	1,720	1,725	1,571
C02	54	0.46	0.21	3,540	3,249	3,440	3,450	3,142
21 LED LIGHTBAR								
B01	27	0.23	0.13	2,177	1,998	2,115	2,122	1,932
B02	51	0.43	0.20	4,354	3,996	4,231	4,244	3,865

Ambient Temperature	Lumen Multiplier
10°C	1.04
15°C	1.03
25°C	1.00
40°C	0.96

ORDERING INFORMATION

IST-B01-LED-E1-BL3-BZ

IST	B01	LED	E1	BL3	BZ		
------------	------------	------------	-----------	------------	-----------	--	--

Product Family ¹

IST= Impact Elite Small Trapezoid

Number of LightBARs ^{2,3}

B01= [1] 21 LED LightBAR

B02= [2] 21 LED LightBARs

C01= [1] 7 LED LightBAR

C02= [2] 7 LED LightBARs

Lamp Type

LED= Solid State Light Emitting Diodes

Voltage

E1=Electronic 120-277V

347=347V

480=480V

Distribution

GZW= Wall Grazer Wide

BL2= Type II w/ Back Light Control

BL3= Type III w/ Back Light Control

BL4= Type IV w/ Back Light Control

SLL=90 Degree Spill Light Eliminator Left

SLR=90 Degree Spill Light Eliminator Right

Finish

AP=Grey

BZ=Bronze

BK=Black

DP=Dark Platinum

GM=Graphite Metallic

WH=White

Options ⁴

P= Button Type Photocontrol (120V, 208, 240, or 277V)

2L= Two Circuits⁶

TR= Tamper Resistant Fasteners

7060=70 CRI/6000K CCT⁷

8030=80 CRI/3000K CCT⁷

ULG=Uplight Glow⁸

LCF=LightBAR Cover Plate Matches Housing Finish

OSB=Occupancy sensor standard with back box matching housing finish. ⁹

BBB=Emergency LED power pack (UL924 listed) 0° C/32° F standard with back box matching housing finish. ^{10, 11, 12}

CWB=Emergency LED cold temperature power pack (UL924 listed) -20° C/-4° F standard with back box matching housing finish. ^{10, 13}

Accessories ¹⁴

MA1254-BZ=Thruway Back Box - Impact Elite Trapezoid¹⁵

MA1253=10kV Circuit Module Replacement

Notes:

- 1 DesignLights™ Consortium Qualified. Refer to www.designlights.org Qualified Products List under Family Models for details.
- 2 Standard 4000K CCT and nominal 70CRI.
- 3 21 LED LightBAR powered at 350mA, 7 LED LightBAR powered at 1A.
- 4 Add as suffix.
- 5 Must specify voltage.
- 6 Only available in 2 bar (B02 or C02) configurations.
- 7 Consult Factory for lead times and lumen multiplier.
- 8 Provides 10% uplight in 2 bar (B02 or C02) configurations and 20% uplight in 1 bar (B01 or C01) configurations.
- 9 Only available in 2 BAR (B02 or C02) configurations; streetside LightBAR will be wired to sensor. Time delay factory setting is 15 minutes.
- 10 Not available with OSB.
- 11 Specify 120 or 277V, (0°C) minimum temperature.
- 12 Consult factory for availability.
- 13 Specify 120 or 277V, (-20°C) minimum temperature.
- 14 Order separately.
- 15 Specify finish (color) in place of "XX".