

**APPLICATION FOR  
URBAN DESIGN COMMISSION  
REVIEW AND APPROVAL**

**AGENDA ITEM #** \_\_\_\_\_  
**Project #** \_\_\_\_\_

	Action Requested
DATE SUBMITTED: <u>OCTOBER 14, 2009</u>	<input type="checkbox"/> Informational Presentation
UDC MEETING DATE: <u>OCTOBER 21, 2009</u>	<input type="checkbox"/> Initial Approval and/or Recommendation
	<input checked="" type="checkbox"/> Final Approval and/or Recommendation

PROJECT ADDRESS: 2300 S. PARK ST.

ALDERMANIC DISTRICT: 14

OWNER/DEVELOPER (Partners and/or Principals) ARCHITECT/DESIGNER/OR AGENT:  
CITY OF MADISON RYAN SIGNS, INC.  
SIEBEL-BALLAGHER REAL ESTATE

CONTACT PERSON: MARY BETH GROWNEY SELENE  
Address: 3007 PERRY ST.  
MADISON, WI 53713  
Phone: 608-271-7979  
Fax: 608-271-7853  
E-mail address: mbgrowneyselene@ryan signs.net

**TYPE OF PROJECT:**  
(See Section A for:)

- Planned Unit Development (PUD)
  - General Development Plan (GDP)
  - Specific Implementation Plan (SIP)
- Planned Community Development (PCD)
  - General Development Plan (GDP)
  - Specific Implementation Plan (SIP)
- Planned Residential Development (PRD)
- New Construction or Exterior Remodeling in an Urban Design District \* (A public hearing is required as well as a fee)
- School, Public Building or Space (Fee may be required)
- New Construction or Addition to or Remodeling of a Retail, Hotel or Motel Building Exceeding 40,000 Sq. Ft.
- Planned Commercial Site

(See Section B for:)

- New Construction or Exterior Remodeling in C4 District (Fee required)

(See Section C for:)

- R.P.S.M. Parking Variance (Fee required)

(See Section D for:)

- Comprehensive Design Review\* (Fee required) CONTINUATION
- Street Graphics Variance\* (Fee required)
- Other \_\_\_\_\_

\*Public Hearing Required (Submission Deadline 3 Weeks in Advance of Meeting Date)

Where fees are required (as noted above) they apply with the first submittal for either initial or final approval of a project.

# Ryan Signs, Inc.

---

3007 Perry Street  
Madison, WI 53713  
608-271-7979 Phone  
608-271-7853 Fax  
mbgrowneyselene@ryansigns.net

October 14, 2009

Mr. Al Martin  
City of Madison Planning Department  
215 Martin Luther King, Jr. Blvd.  
Madison, WI 53701

Re: Letter of Intent for Urban Design Commission's Review of a Comprehensive Design Review Plan at The Villager Development, 2300 S. Park Street  
**RESUBMITTAL**

Dear Al;

The attached **revised** document package describes the existing and proposed Comprehensive Signage Plan for the exterior building signage at The Villager Development, located at 2300 S. Park Street. We are seeking Urban Design Commission approval of the comprehensive exterior building signage package. **Notes incorporating changes as suggested by UDC at their September 16 meeting are shown in red.**

## **Objective**

We intend to describe the design and integration of the street graphics, retail tenants, office tenant and out-lot signage. Principal goals are to create identity for The Villager and its tenants, support commercial activity, promote vitality and establish wayfinding for tenants, clients/customers and visitors.

- To effectively display tenant signage on the revised building façade
- To present professional entrance signage for "The Atrium" façade
- To effectively identify tenants in out-lot buildings

The execution of the objective and goals, as they relate to the mixed-use relationship and size of the development, has created opportunities to address scale appropriate graphics to maximize legibility in each context in which the graphics are intended to be viewed. This package illustrates the extent and scope of The Villager Development exterior signage and includes a summary of all proposed signage. Included below is the intent of and commentary on each type of signage for the development. Please refer to the document package for additional information on specific signage detail.

## **Purpose of the Comprehensive Design Plan**

To determine whether unique, exceptional and innovative use of materials, design, color, lighting and other design elements resulting in visual harmony created between signs and buildings and building site are sufficient to warrant special allowances in signage area beyond the restrictions contained in the City of Madison Sign Ordinance.

Responses to UDC comments/suggestions at September 16, 2009 meeting:

1. The Villager
  - A. Tenant Signage
    - a. Commercial tenant signs shall consist of individual, externally illuminated letters. The letters will be fabricated aluminum and will be 2" deep.
    - b. The maximum letter height for any component of a commercial tenant sign shall be 30" (including logos).
    - c. Tenants shall be allowed to incorporate their corporate standard in typeface and color.
    - d. The sign bands were approved by UDC in December of 2008 in size and number.
    - e. External lighting of all tenant signs on The Villager/Atrium Building
  - B. Dane County Human Services
    - a. The letters have been increased to 15". The fabrication detail of the letters will be identical to the commercial tenants. These letters will be installed above the entrance canopy.
  - C. Site Plan
    - a. The site plan is presented in two phases; (1) the original CDP as approved by UDC in July of 2007 and (2) the proposed signage incorporated into the site plan.
    - b. Enter and Exit signs have been maintained at each of the vehicular/pedestrian entrances to the site. These are strategic locations that enable those driving, walking, biking and using public transportation to easily identify the ingress locations. When the pedestrian and vehicular access points don't intersect, it provides safety to and awareness of vehicles.
2. The Urban League/Planned Parenthood/Madison Public Library Building
  - A. Urban League
    - a. The North elevation letters have been moved to center between the windows.
    - b. The South elevation letters have been moved to center between the windows.
    - c. The "Center for Economic Development & Workforce Training" have been increased in size to be more compatible with the Madison Public Library signage.
  - B. Planned Parenthood
    - a. The North elevation letters will remain. They have been moved to the west in line with the windows.
    - b. We explored the option of replacing these letters with a monument sign. The urban site does not lend itself to a freestanding sign and Planned Parenthood of Wisconsin, while aware of the future building, and the potential of being somewhat obscured, wants their sign on the building.
  - C. Madison Public Library
    - a. The Madison Public Library was asked to consider placing a sign on the East elevation (Park Street). Following discussions with the MPL, it has been determined to add a second sign to the North elevation, with no sign on the East elevation (other than the projecting sign).
  - D. Multi-Tenant Projecting Sign
    - a. The location of this sign has been altered to the South.

The following is a listing of sign types located on the site plan and building elevations:

- Sign Type 1            THE VILLAGER Project Site Sign (Existing)  
This main identification sign serves as a branding opportunity and provides street identity for the overall development. The "Farmers Market" sign is seasonal. (Size and location as depicted in the documents.)
- Sign Type 2            Enter/Exit Directional Signs (existing design)  
These signs will enhance the identity of the development as established by the main identification sign. The signs will be located at the ingress and egress drives of the development. The development currently includes one enter sign and one exit sign. We are proposing three additional enter and exit signs. (Size and locations as depicted in the documents.)
- Sign Type 3            Directional Signs (existing design)  
The site directional signs are included to provide for good traffic flow and to provide assurance to the public that they are in the right area for the services for which they will be served. Due to the increased number of services and retail tenant opportunities, adding two more directional signage locations will provide for better direction within the development site. (Size and locations as depicted in the documents.)
- Sign Type 4            The Atrium Building Sign  
The Atrium will serve as a professional environment. The building signage will be limited to the name only. Tenants of The Atrium will not be listed on the sign band. (Size and location as depicted in the documents.)
- Sign Type 5            The Atrium Building Directory Sign  
Tenants will be listed on a building mounted sign. The sign will be located at pedestrian level. (Size and location as depicted in the documents.)
- Sign Type T            Retail Tenant Signs  
Tenants, as identified by the landlord, will be allowed one signable area on the building façade. The sign band is established through the use of perforated metal. (Size and location as depicted in the documents.)
- Sign Type T.1           Tenant Sign – Above Canopy  
Tenant, as identified by the landlord, will be allowed one above canopy sign located on the architecturally detailed canopy. (Size and location as depicted in the documents.)
- Urban League Out-Lot Building**
- Sign Type 6            Major Tenant Sign  
The major tenant will be identified above the second floor of the North and South elevations of the center out-lot building. Size and location as depicted in the documents.)
- Sign Type 7            Major Tenant Above-Canopy Sign  
The major tenant will be allowed one above-canopy sign located at the South entrance to the building. (Size and location as depicted in the documents.)

- Sign Type 8                      Secondary Major Tenant Sign  
The secondary major tenant will be identified with a sign above the second floor, North elevation of the center out-lot building. (Size and location as depicted in the documents.)
- Sign Type 9                      First Floor Secondary Major Tenant Sign  
The first floor secondary major tenant will be identified with a sign located on the South elevation, first floor location and the North elevation, first floor location. (Size and location as depicted in the documents.)
- Sign Type 10                     Center Out-Lot Projecting Sign  
In lieu of a ground/monument sign, the building will have a comprehensive projecting sign to be utilized by all tenants. (Size and location as depicted in the documents.)

**South Out-Lot Building**

- Sign Type 11                     To provide for multiple tenant signage (to be determined) on the North, South, East and West locations. (Size and location as depicted in the documents.)

**North Out-Lot Building**

- Sign Type 12.1                   Building Letters  
To provide for illuminated tenant building signage (to be determined) on the North elevation.
- Sign Type 12.2                   Monument Sign  
To provide for double face, internally illuminated, business monument sign (to be determined).
- Sign Type 12.3/12.4             Parking Lot Directional Signs  
To provide for double face, non-illuminated, freestanding Parking Lot Directional signs (to be determined).

**Existing Tenant Signs**      The existing tenant signs on the South building of the existing Villager Development are not included in this CDP. These signs will remain unchanged until such time the South building is renovated or raised. If renovated, the signage standards as approved by UDC will be implemented.

Following is a comparison of the City of Madison Sign Ordinance and the signage, as proposed, that does not meet Chapter 31 stipulations.

Following is a comparison of the City of Madison Sign Ordinance and the signage, as proposed, that does not meet Chapter 31 stipulations.

Code	Sign Type	Allowed	Existing and Proposed
31.08	<b>Ground Signs</b>	Limit of 2 per zoning lot 35 MPH, 6+ Traffic Lanes Maximum Square Footage: 72 Maximum Height: 18'	<b>Sign Type 1</b> 5' x 14' = 70 sq. ft. With Seasonal "Farmers Market" 3' x 7' = 21 sq. ft. TOTAL = 91 sq. ft. 21'-6" overall height ===== <b>Sign Type 3 (1 Existing; 2 Proposed)</b> 7' x 28" = 16.31 sq. ft. x 3 = 49 sq. ft. 7' overall height ===== <b>Sign Type 12.2 (Detail to be determined)</b> Estimate of 32 sq. ft. Estimated overall height not to exceed 8'
31.14 (b) 4	<b>Parking Lot Directional Signs</b>	Limited to one sign per exit or entrance Maximum Square Footage: 3 Maximum Height: 10' Illumination: No	<b>Sign Type 2 (2 Existing; 6 proposed)</b> 3' x 3' = 9 sq. ft. x 8 = 72 sq. ft. Illuminated Yes (Base is included in calculation) ===== <b>Sign Type 12.3 and 12.4 (3 proposed)</b> 3' x 3' = 9 sq. ft. x 3 = 27 sq. ft.
31.07	<b>Wall Signs</b>	Not more than 30% of the signable area (based on 25,000+ square footage of project) per tenant sign	Not to exceed 40% of tenant signable area or 2 square feet of signage for each lineal foot of building frontage
31.07 (2) (b) 1.	<b>Wall Signs Crossing Architectural Detail</b>	The signable area for a wall sign is determined by the area of the façade that is free of doors, windows (for purposes of this definition, spandrel panels or other non-vision glass used as an exterior building material are not considered windows) or other major architectural detail, and that extends no higher than the juncture of the wall and the roof, or in the case of a façade that includes a parapet wall, no more than four (4) vertical feet of the parapet wall may be included in the measurement of the signable area."	<b>Sign Type T</b> To allow for the use of multiple spandrels in the event a tenant's overall leased façade includes multiple sign spandrels.

31.071 (2)	<b>Above-Canopy Signs</b>	<ul style="list-style-type: none"> <li>-In lieu of wall sign/canopy fascia sign</li> <li>-Cannot extend above roof line</li> <li>-Business Name or logo only</li> <li>-No longer than canopy length</li> </ul>	Signs, as proposed, meet the requirement of above-canopy signs, <u>except</u> that Major tenant Urban League Out-lot Building, is allowed two signs on one elevation.
31.09	<b>Projecting Signs (Sign Type 10)</b>	Based on number of traffic lanes and speed limit, code allows for a 32 square foot projecting sign. If a projecting sign is placed in lieu of a ground sign, the maximum allowable sign refers to section 31.08 (ground signs).	<p>Sign as proposed is 12' x 4'-6" = 54 square feet.</p> <p>If no other ground sign existed, this sign would be in compliance.</p> <p>For purposes of review, the square footage of this sign should be included with the ground sign section as noted above.</p>
31.11	<b>Advertising Signs (Billboards)</b>	(Legal) Non-conforming and are allowed only in C2, C3, C3L Commercial Districts and M1 & M2 Manufacturing Districts with regulations.	The City of Madison is currently involved in a lease situation with Adams Outdoor. They are currently engaged in efforts to remove the structures from the site.

1

14'



21'

3/8" = 1'.0"

2

36" 36"



3/8" = 1'.0"

5

30"

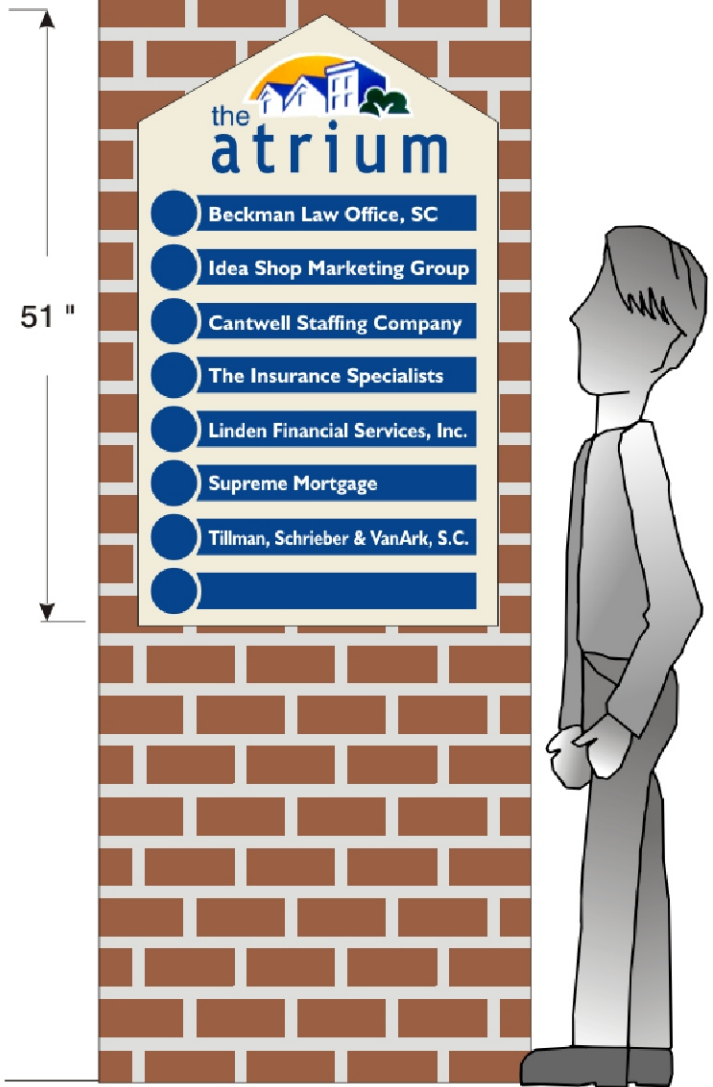

51"

3/4" = 1'.0"

3

28"



7'

3/8" = 1'.0"

<b>Ryan Signs, Inc.</b>		SCALE: VARIES	APPROVED:
3007 Perry Street • Madison, WI 53713 • Tel (608) 271-7979 • Fax (608) 271-7853		DATE: 8/24/09	Copyright 2009 by Ryan Signs, Inc.
<b>SIEGEL GALLAGHER - VILLAGER MALL UPDATE</b>		REVISED: 10/13/09	DRAWN BY: KW
<small>These plans are the exclusive property of Ryan Signs, Inc. and are the result of the original design work of its employees. They are submitted to you or your company for the sole purpose of your consideration of whether to purchase from Ryan Signs, Inc., Madison, Wisconsin a sign designed and manufactured according to these plans. Distribution or exhibition of these plans to anyone other than employees of your company or use of these plans to construct a sign similar to the one embodied herein is expressly prohibited. In the event that such use, distribution or exhibition occurs, the undersigned expressly agrees to pay to Ryan Signs, Inc. the sum of 25% of our purchase price as quoted to you. This covenant of payment is acknowledged to be compensation for the time, effort and talent devoted to the preparation of the plans.</small>		DRAWING NUMBER: <b>4619B</b>	
client signature _____			



# Existing Signage

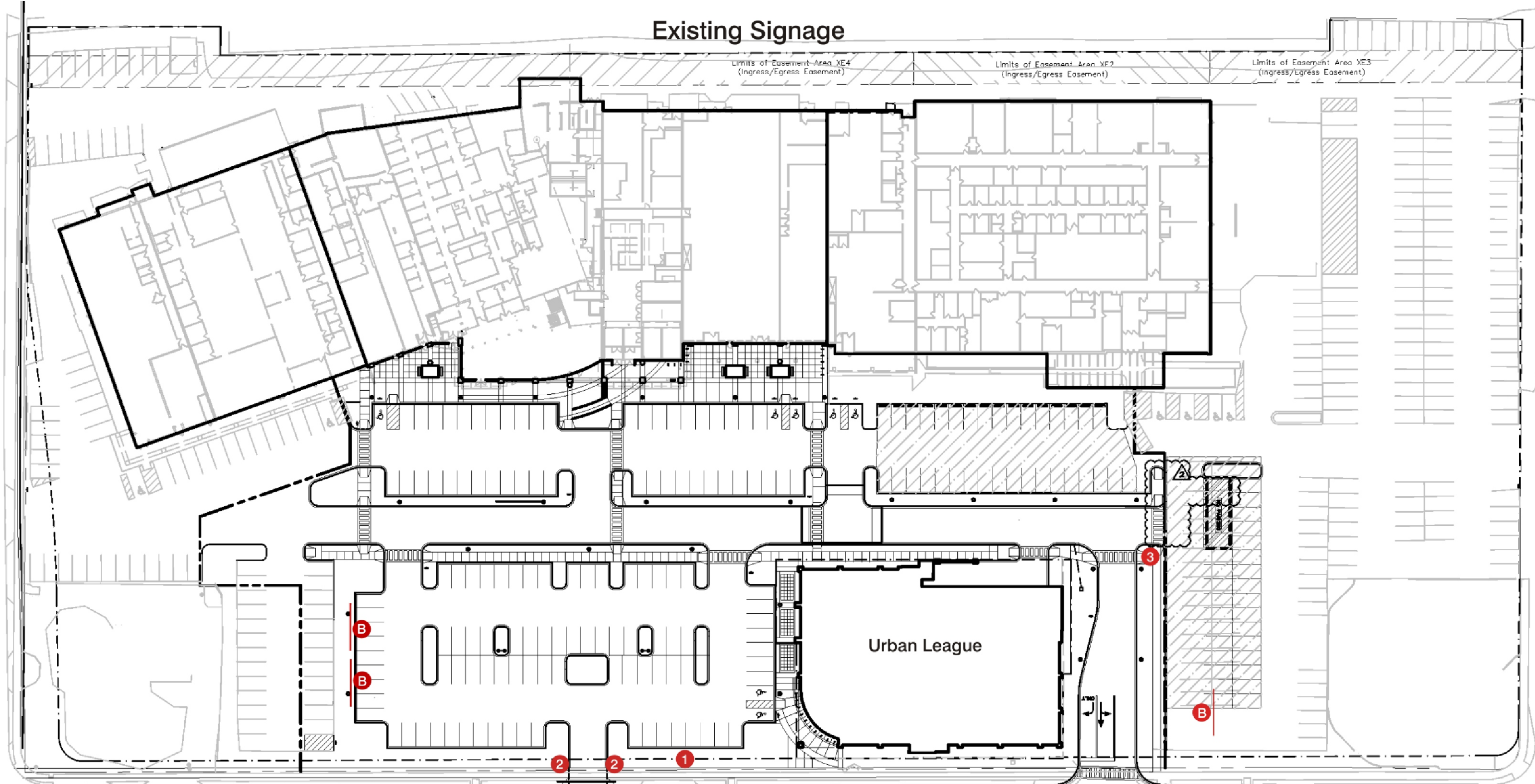

## Park Street

### Existing Mall Signage

- 1 Main Pylon
- 2 Enter/Exit
- 3 Directional
- B Billboard

— Pedestrian Traffic

# Existing & New Signage

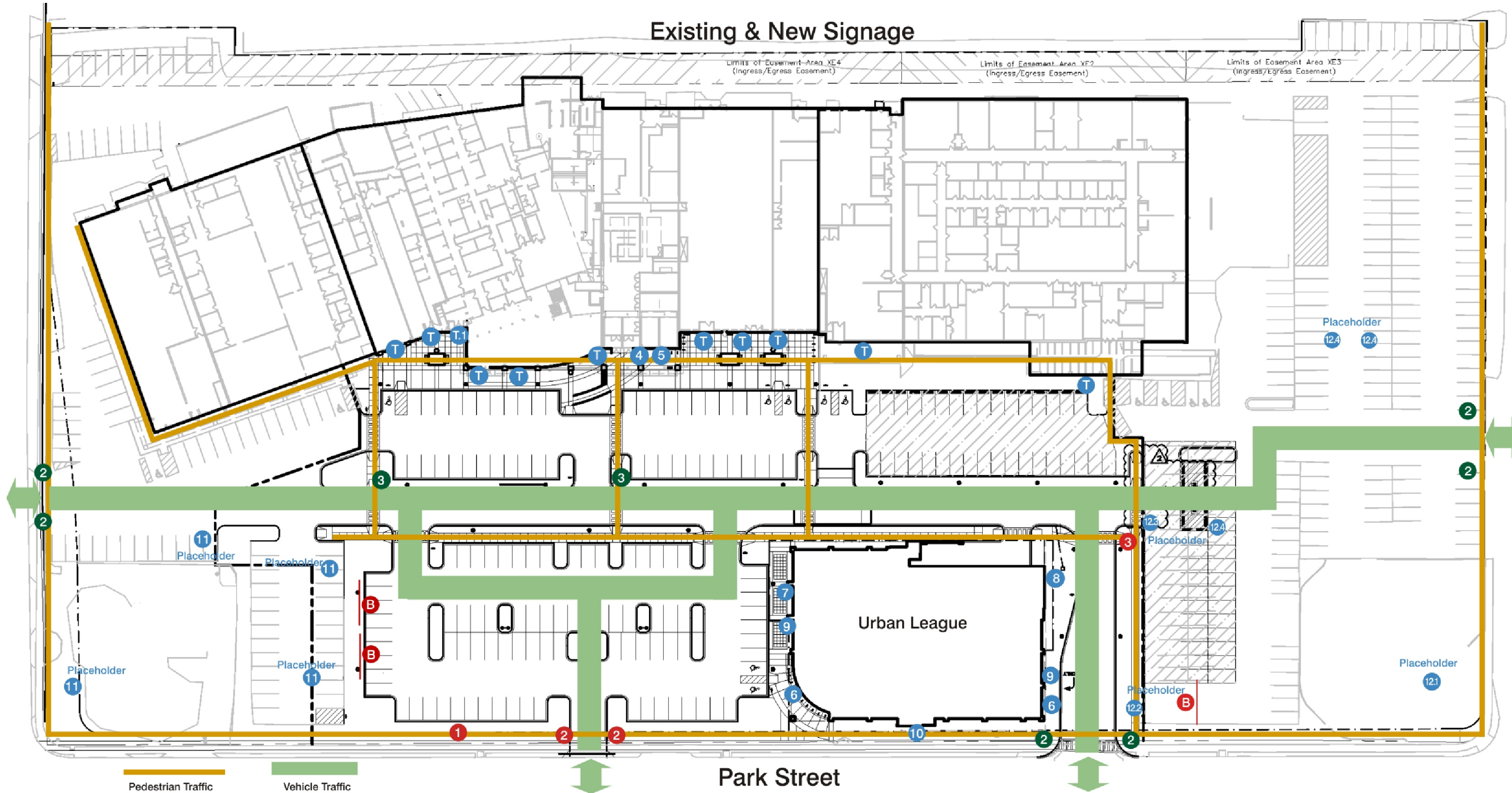

## Existing Mall Signage

- 1 Main Pylon
- 2 Enter/Exit
- 3 Directional
- B Billboard

## New Directional Signage

- 2 Enter/Exit
- 3 Directional

- T Cricket
- T VIP Nails
- T Dane County Human Services
- T Future Restaurant
- T Future Coffee Shop

- T Yue Wah Oriental Foods
- T Atrium
- T MATC
- T Village Sports Town

## New Tenant Signage

- 4 Atrium Sign
- 5 Atrium Directory
- 6 Urban League
- 7 Urban League
- 8 Planned Parenthood
- 9 Madison Public Library
- 10 Building Projecting Sign
- 11 South Out-Lot Building

- 121 Access Community Health Centers
- 122 D/F Monument
- 123 Patient Drop-Off
- 124 Parking Only

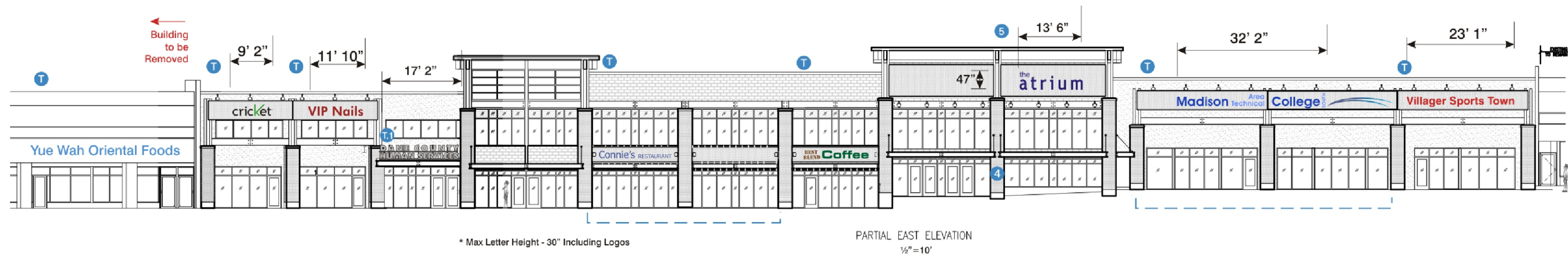

### External Lighting

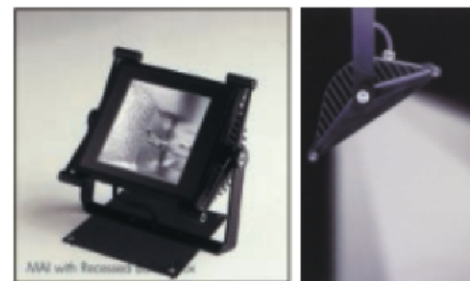

Adjustable External Lighting

Letter Mount to Perf. Sheet (Align Mounting w/Hole Spacing on Sheet)

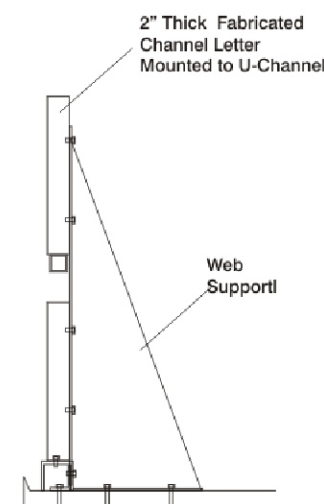
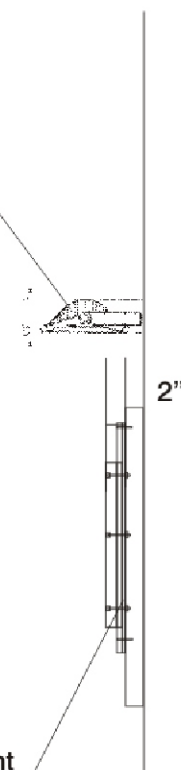

Dane County Human Services Canopy Profile

<b>Ryan Signs, Inc.</b> 3007 Perry Street • Madison, WI 53713 • Tel (608) 271-7979 • Fax (608) 271-7853	SCALE: 1/2" = 10'	APPROVED:
	DATE: 8/24/09	Copyright © 2009 by Ryan Signs, Inc.
<b>SIEGEL GALLAGHER - VILLAGER MALL UPDATE</b>	REVISED: 10/13/09	DRAWN BY: KW
<small>These plans are the exclusive property of Ryan Signs, Inc. and are the result of the original design work of its employees. They are submitted to you or your company for the sole purpose of your consideration of whether to purchase from Ryan Signs, Inc., Madison, Wisconsin a sign designed and manufactured according to these plans. Distribution or exhibition of these plans to anyone other than employees of your company or use of these plans to construct a sign similar to the one embodied herein is expressly prohibited. In the event that such use, distribution or exhibition occurs, the undersigned expressly agrees to pay to Ryan Signs, Inc. the sum of 25% of our purchase price as quoted to you. This covenant of payment is acknowledged to be compensation for the time, effort and talent devoted to the preparation of the plans.</small>		DRAWING NUMBER: <b>4619</b>



North Elevation

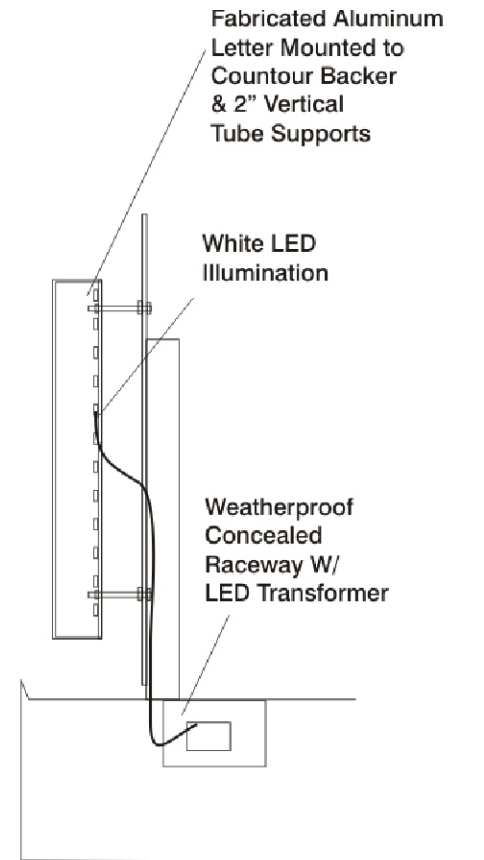

Madison Public Library Profile



South Elevation

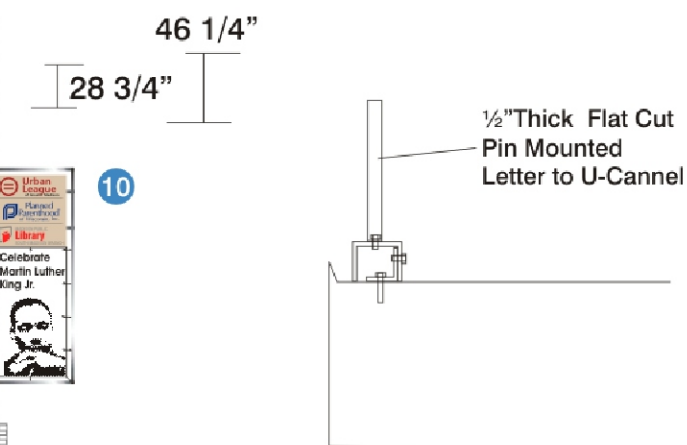

Urban League Canopy Profile

Not to Scale

<b>Ryan Signs, Inc.</b>		SCALE: 3/32" = 1'-0"	APPROVED:
3007 Perry Street • Madison, WI 53713 • Tel: (608) 271-7979 • Fax: (608) 271-7853		DATE: 8/24/09	Copyright © 2009 by Ryan Signs, Inc.
<b>SIEGEL GALLAGHER - VILLAGER MALL UPDATE</b>		REVISED: 10/14/09	DRAWING NUMBER: 4619A
These plans are the exclusive property of Ryan Signs, Inc. and are the result of the original design work of its employees. They are submitted to you or your company for the sole purpose of your consideration of whether to purchase from Ryan Signs, Inc., Madison, Wisconsin, a sign designed and manufactured according to these plans. Distribution or exhibition of these plans to anyone other than employees of your company or use of these plans to construct a sign similar to the one embodied herein is expressly prohibited. In the event that such use, distribution or exhibition occurs, the undersigned expressly agrees to pay to Ryan Signs, Inc. the sum of 25% of our purchase price as quoted to you. This covenant of payment is acknowledged to be compensation for the time, effort and talent devoted to the preparation of the plans.		DRAWN BY: KW	client signature

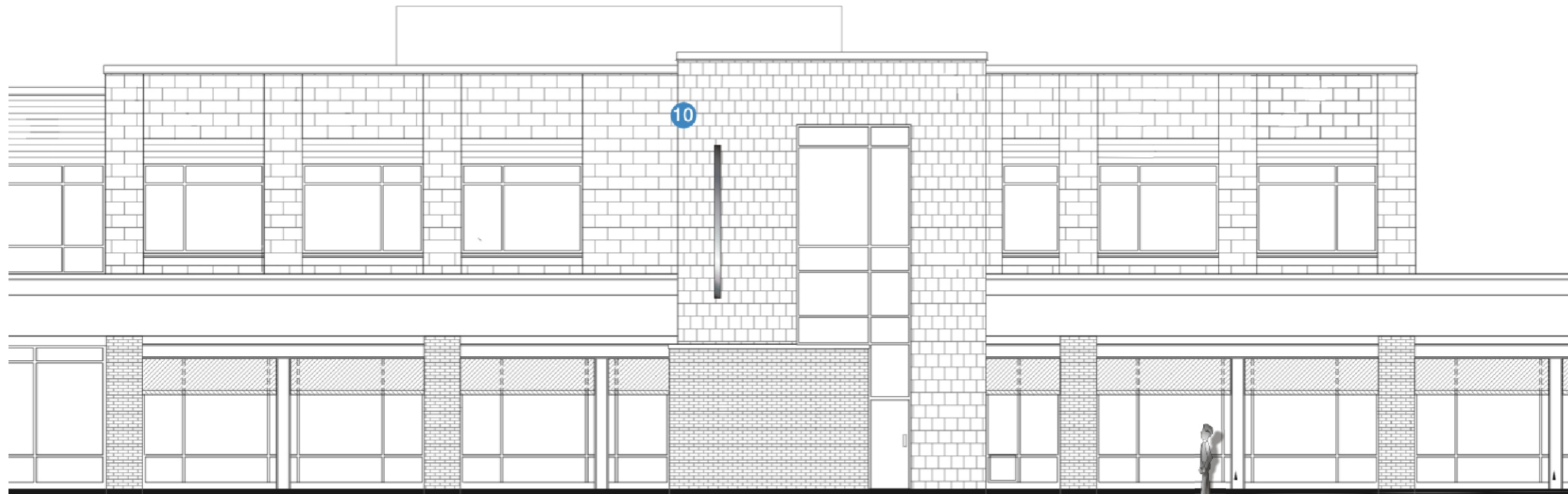

East Elevation 3/32" = 1'.0"

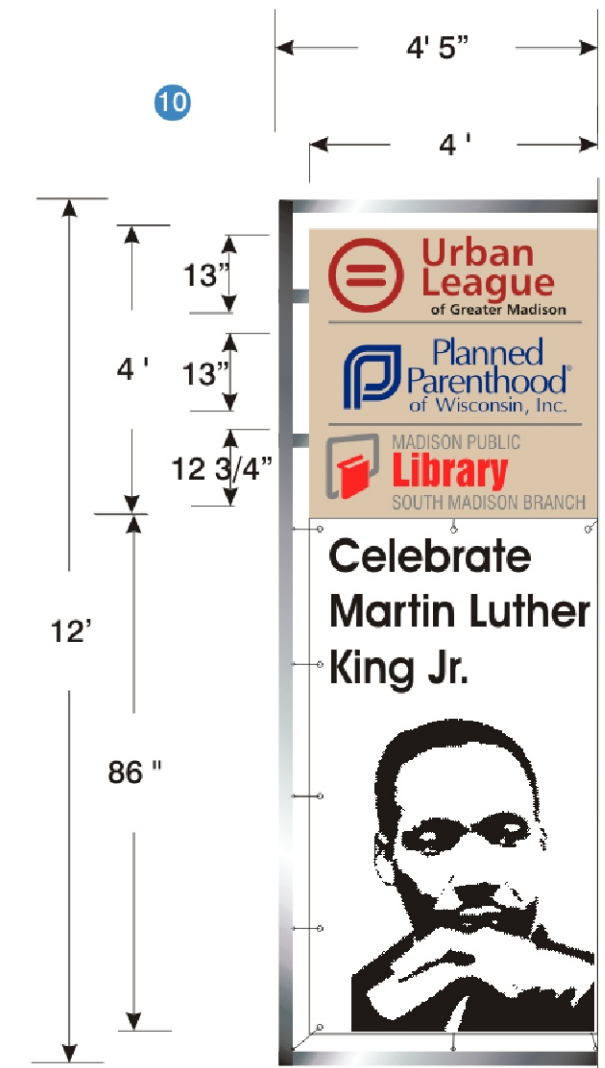

2" x 6" Aluminum Frame  
Bottom 4'x 86" Interchangeable  
Banner Space

3/8" = 1'.0"

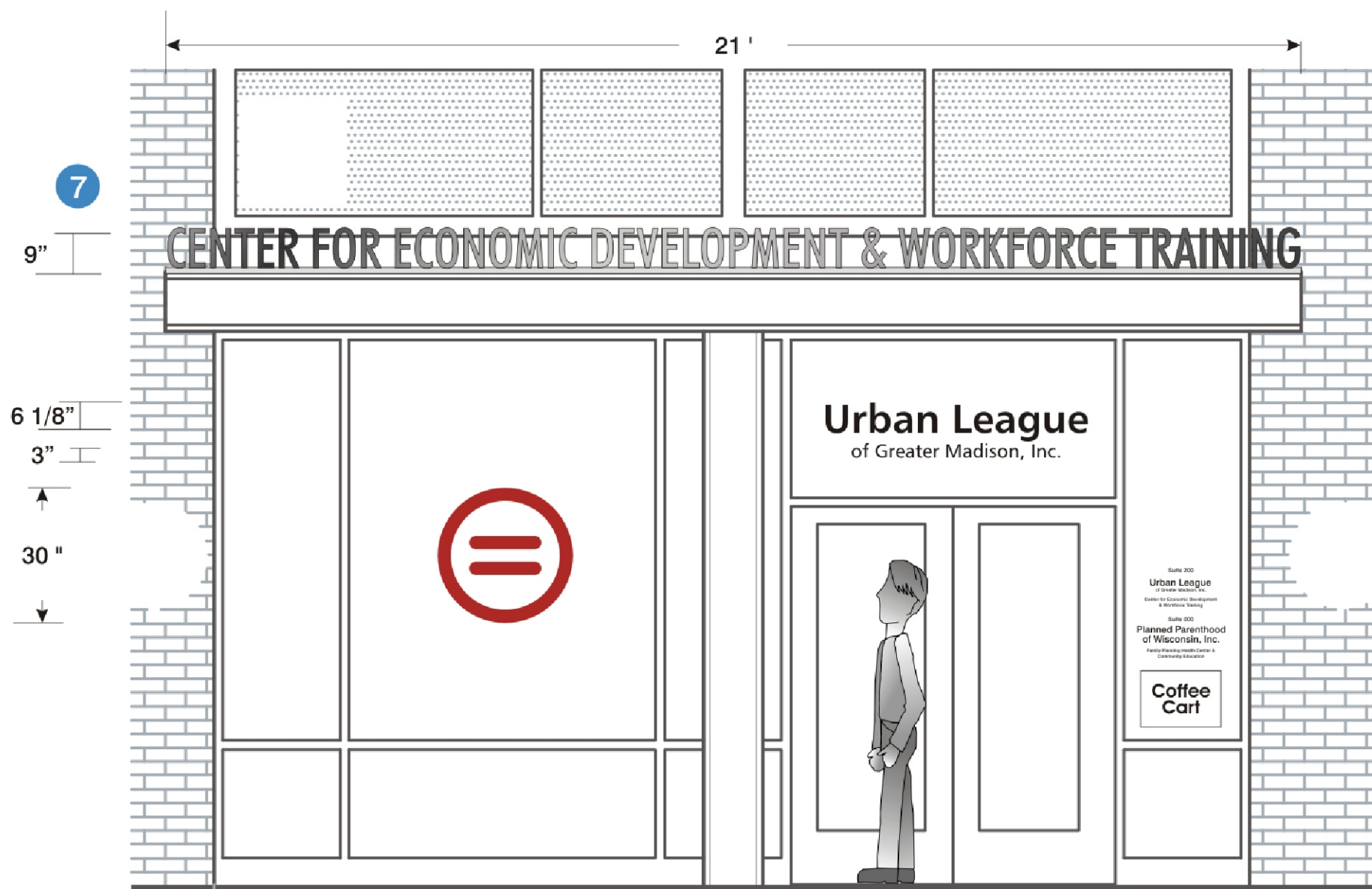

3/8" = 1'.0"

<b>Ryan Signs, Inc.</b>		SCALE: VARIES	APPROVED:
3007 Perry Street • Madison, WI 53713 • Tel: (608) 271-7979 • Fax: (608) 271-7853		DATE: 8/24/09	
<b>SIEGEL GALLAGHER - VILLAGER MALL UPDATE</b>		REVISED: 10/14/09	Copyright © 2009 by Ryan Signs, Inc.
These plans are the exclusive property of Ryan Signs, Inc. and are the result of the original design work of its employees. They are submitted to you or your company for the sole purpose of your consideration of whether to purchase from Ryan Signs, Inc. Madison, Wisconsin a sign designed and manufactured according to these plans. Distribution or exhibition of these plans to anyone other than employees of your company or use of these plans to construct a sign similar to the one embodied herein is expressly prohibited. In the event that such use, distribution or exhibition occurs, the undersigned expressly agrees to pay to Ryan Signs, Inc. the sum of 25% of our purchase price as quoted to you. This covenant of payment is acknowledged to be compensation for the time, effort and talent devoted to the preparation of the plans.		DRAWN BY: KW	DRAWING NUMBER: <b>4619A</b>
			client signature