

REVISIONS

**KADUSHIN GARAGE ADDITION**

206 North Spooner Street  
Madison, WI 53726

Jeff Gaard - SZK Designs

1/4"=1'-0"

4/27/15

**D1**

00101

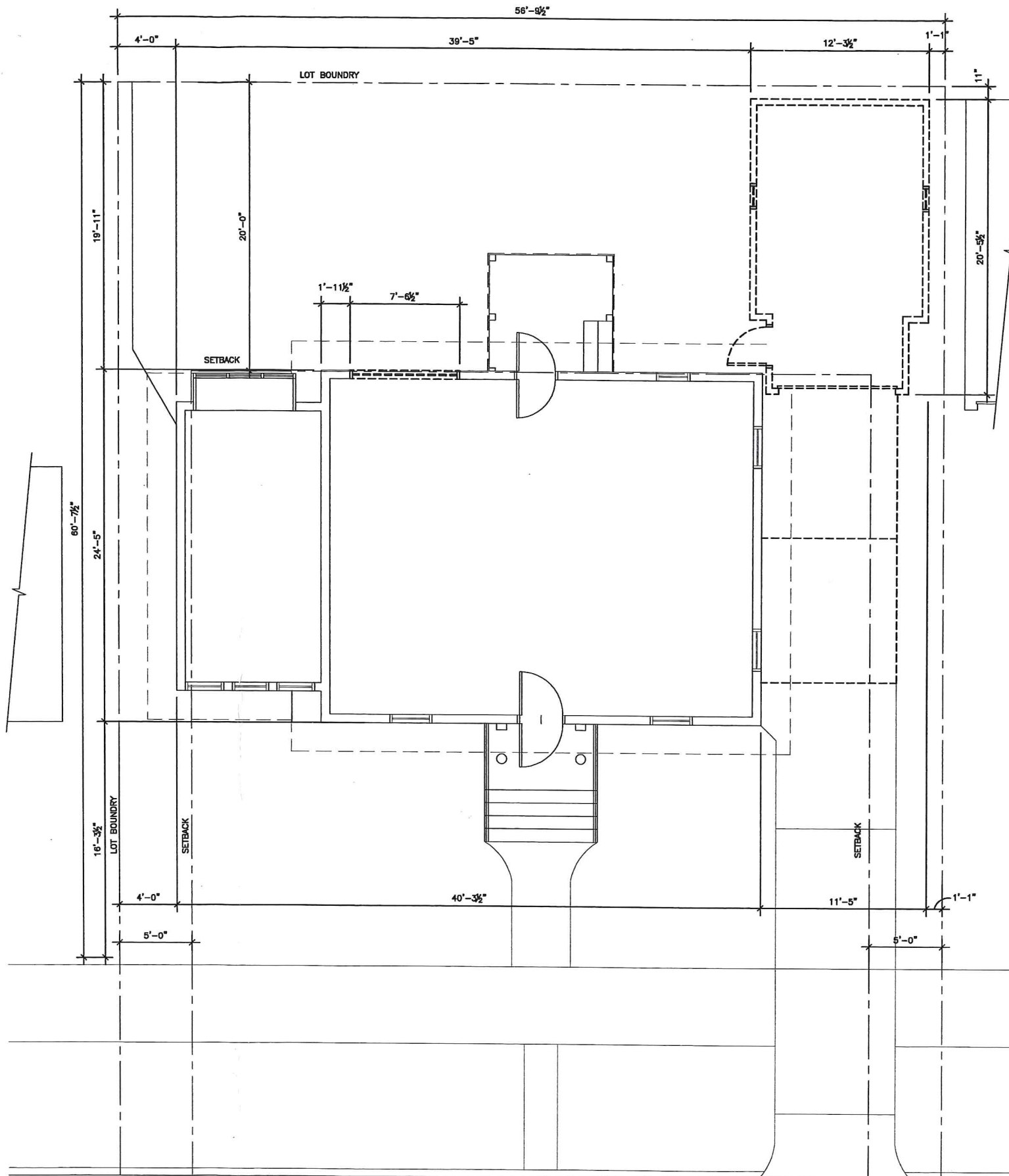

**1 FIRST FLOOR DEMO PLAN**  
1/4"=1'-0"

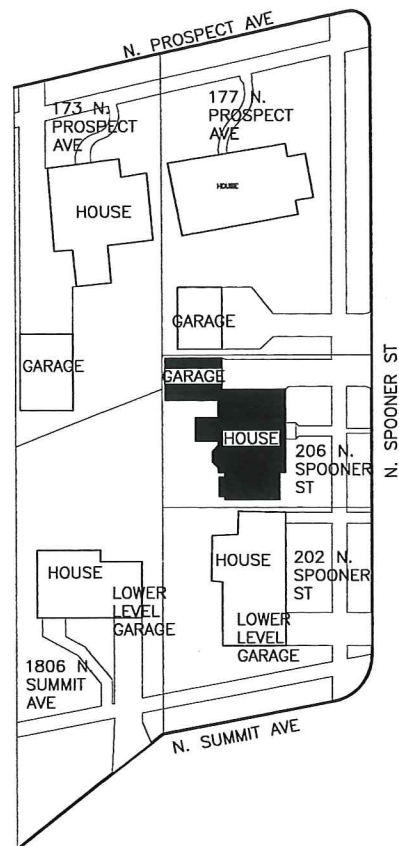

**2 NEIGHBORHOOD BLOCK PLAN**  
NTS



**3 NEIGHBORHOOD SITE PLAN**  
NTS

**4 SECOND FLR DEMO PLAN**  
1/4"=1'-0"

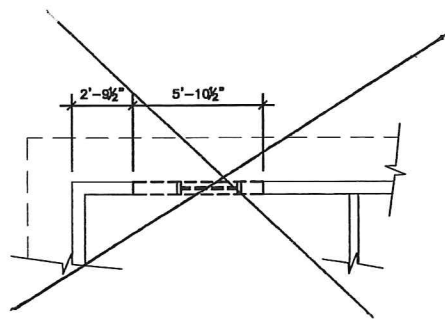

REVISIONS

ZONING INFORMATION

TRC3 ZONING AREA  
 3,443 SF LOT  
 752 SF BACK YARD  
 1380 SF NEW BUILT  
 COVERAGE = 40%

TYPICAL WALL  
 CONSTRUCTION (MEETS  
 3/4 HOUR FIRE RATING):  
 2x6 WD STUD WALL W/  
 P.T. LAP WD SIDING, TYVEK  
 HOUSEWRAP, 7/16" O.S.B.  
 SHEATHING, R-19 BATT  
 INSULATION, 4 MIL VAPOR  
 BARRIER, 1/2" GYP BD

TYPICAL WINDOWS:  
 MARVIN CLAD ULTIMATE  
 DOUBLE HUNG W/  
 SIMULATED DIVIDED LITE  
 WITH SPACER BAR (SDLS)

KADUSHIN GARAGE ADDITION

206 North Spooner Street  
 Madison, WI 53726

Jeff Gaard - SZK Designs

1/4"=1'-0"

4/27/15

A1

00101

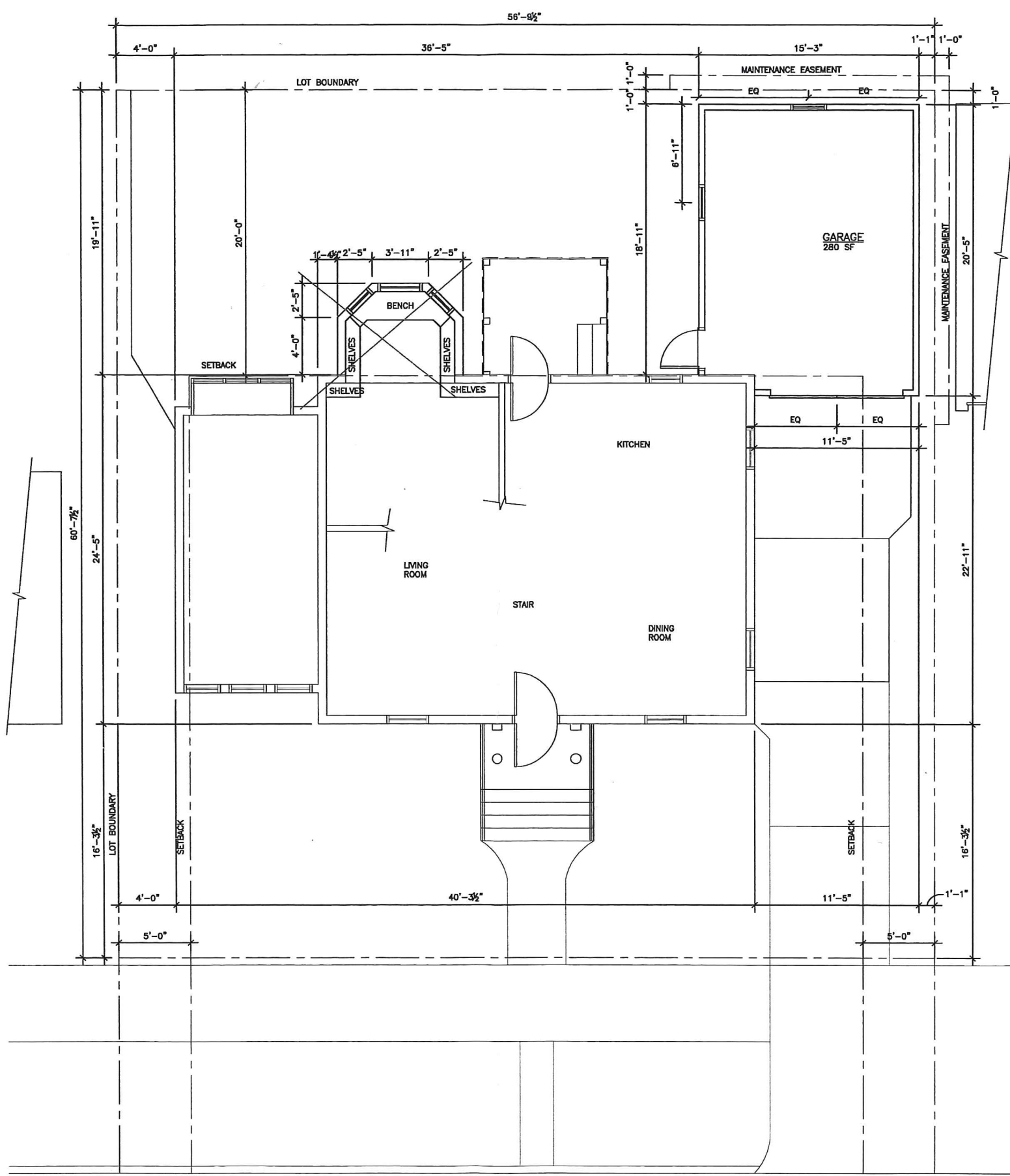

1 FIRST FLOOR PLAN  
 1/4"=1'-0"

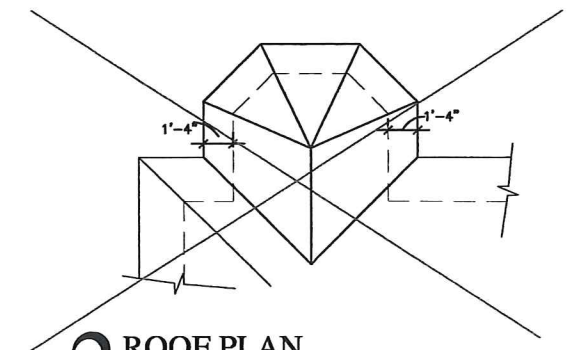
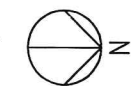

2 ROOF PLAN  
 1/4"=1'-0"

Bay window omitted from project

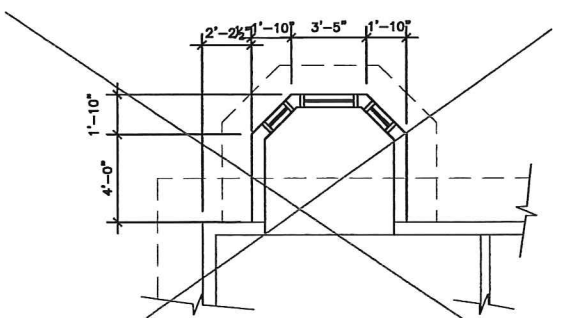

3 SECOND FLOOR PLAN  
 1/4"=1'-0"

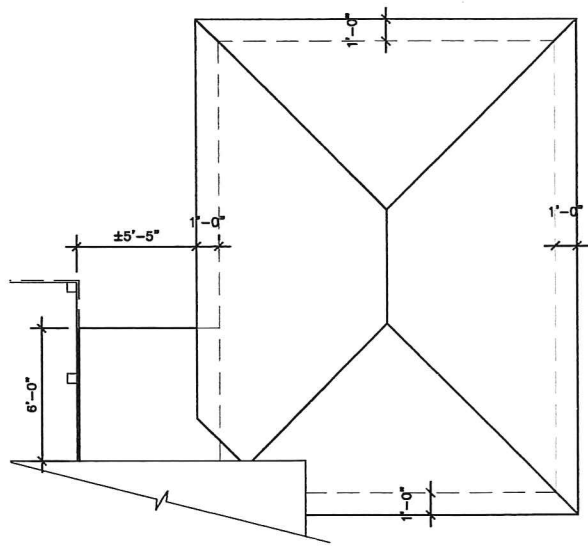

4 ROOF PLAN  
 1/4"=1'-0"

REVISIONS

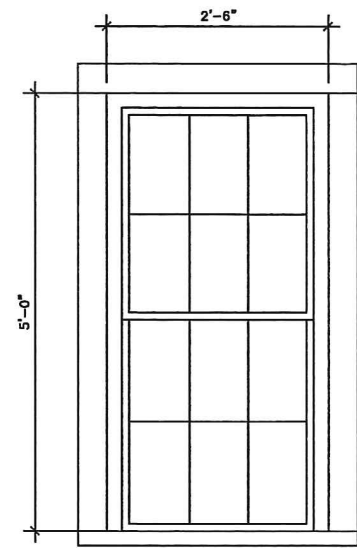

MARVIN CLAD ULTIMATE DOUBLE HUNG  
W/ SIMULATED DIVIDED LITE WITH  
SPACER BAR (SDLS)

**5** TYP WINDOW  
1"=1'-0"

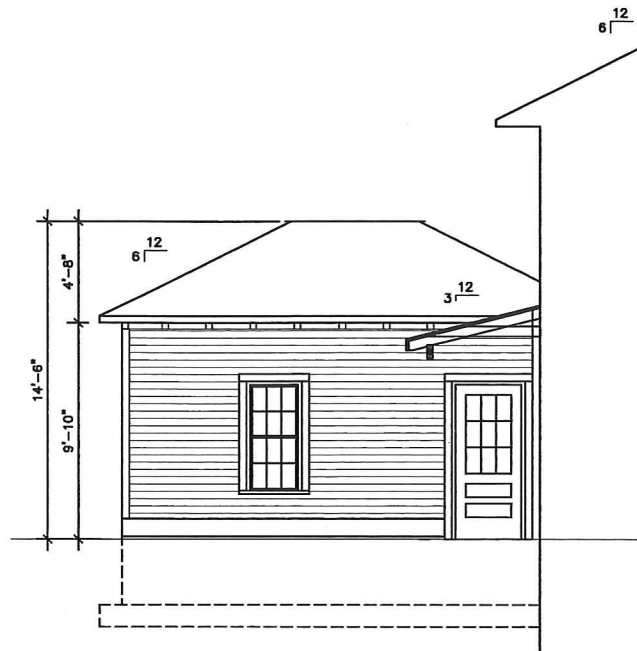

**4** SOUTH EXTERIOR ELEVATION  
1/4"=1'-0"

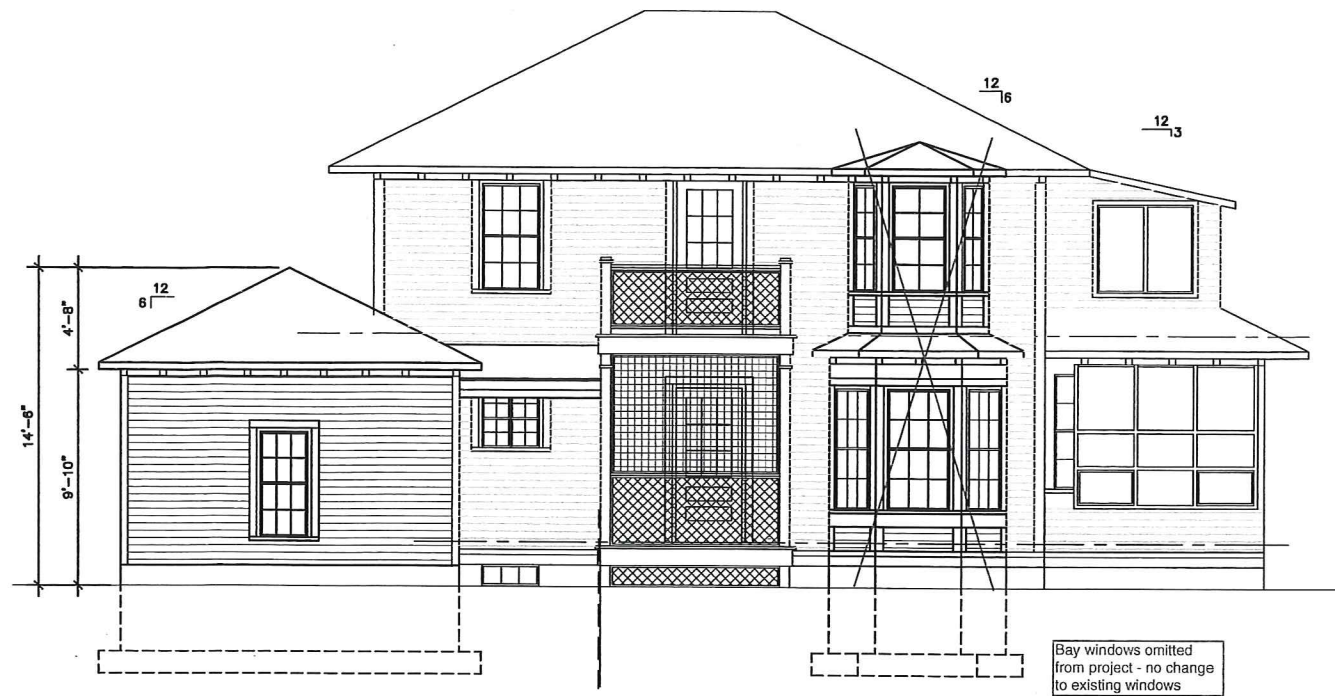

**3** WEST EXTERIOR ELEVATION  
1/4"=1'-0"

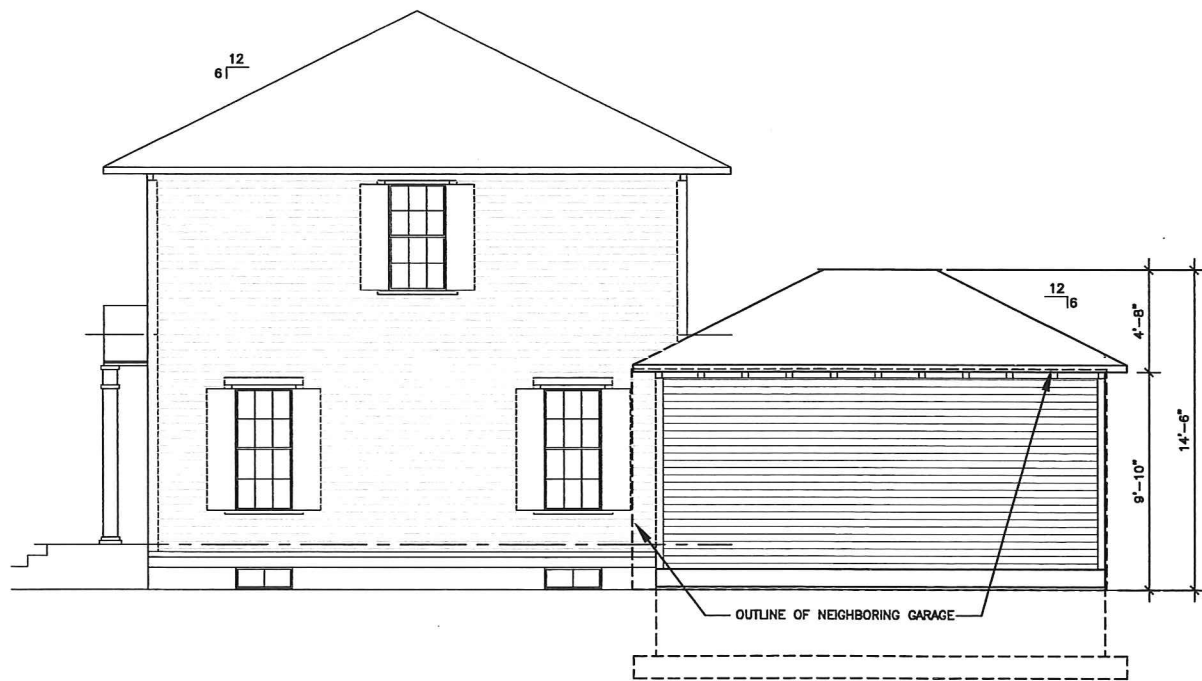

**2** NORTH EXTERIOR ELEVATION  
1/4"=1'-0"

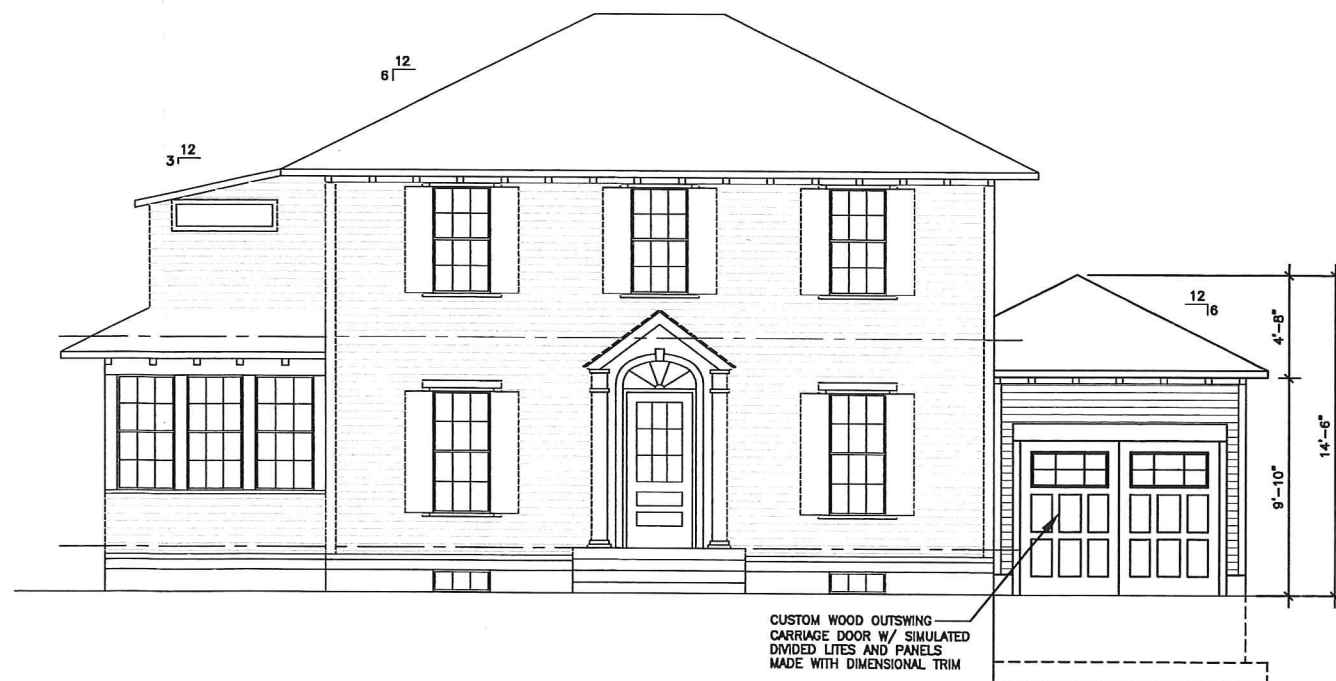

**1** EAST EXTERIOR ELEVATION  
1/4"=1'-0"

**KADUSHIN GARAGE ADDITION**

206 North Spooner Street  
Madison, WI 53726

Jeff Gaard - SZK Designs

1/4"=1'-0"

4/27/15

**A2**

00101

REVISIONS

**KADUSHIN GARAGE ADDITION**

206 North Spooner Street  
Madison, WI 53726

Jeff Gaard - SZK Designs

1/4"=1'-0"

4/27/15

**A3**

00101

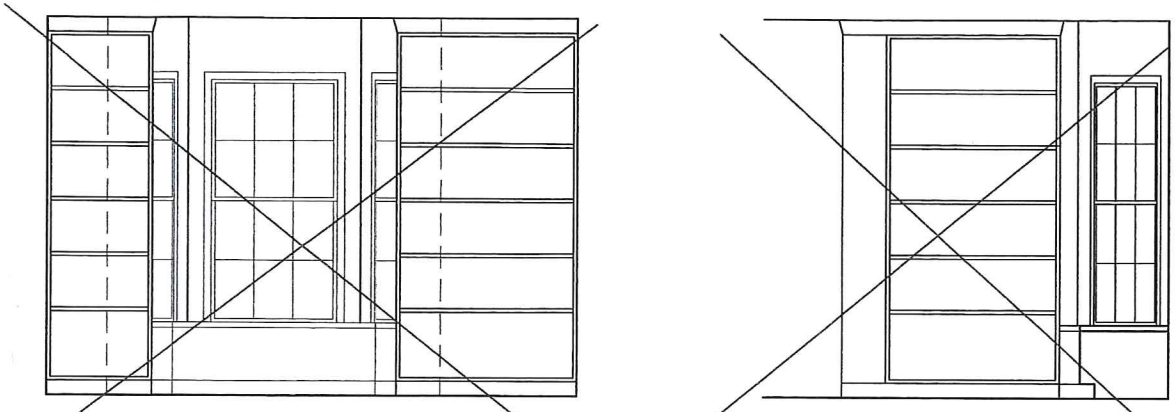

**2** INTERIOR ELEVATIONS  
1/2"=1'-0"

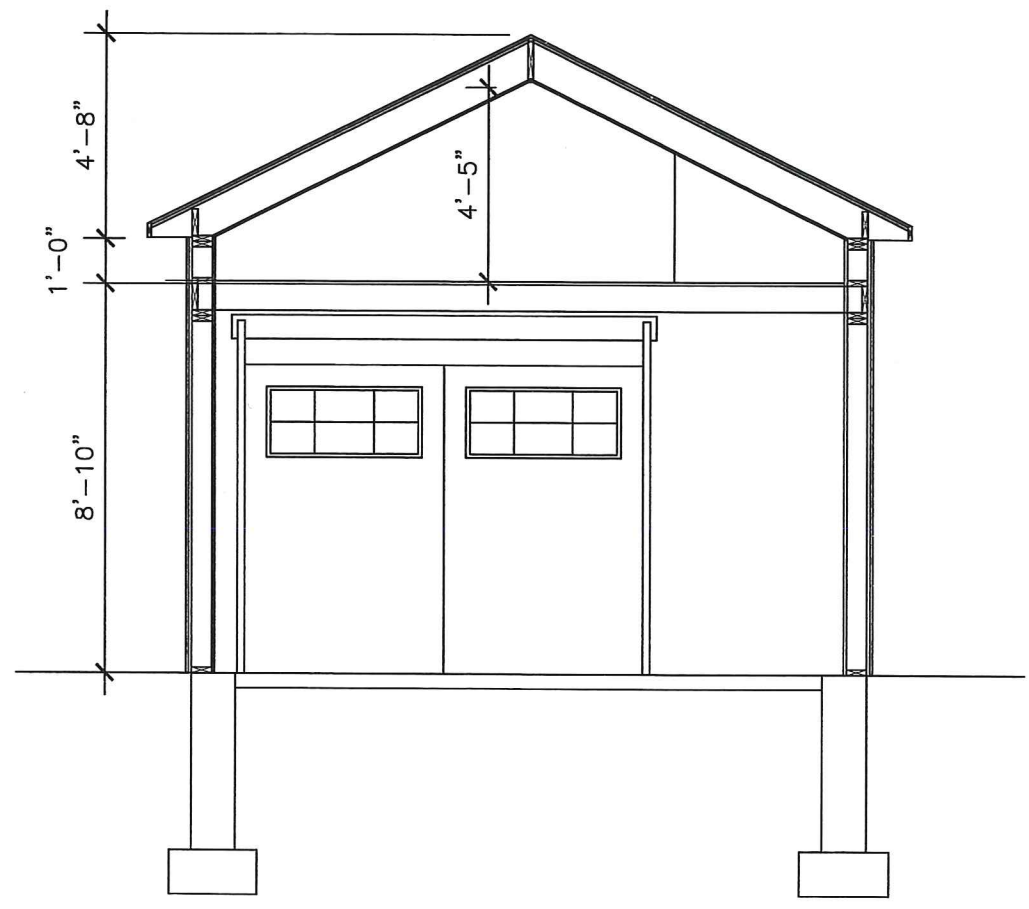

**1** NORTH/SOUTH SECTION  
1/2"=1'-0"



202 N SPOONER ST

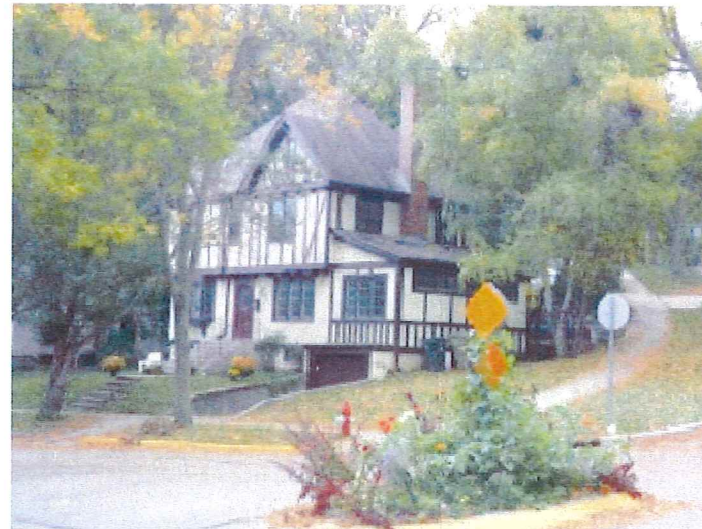

126 N SPOONER ST  
(ROOM ABOVE GARAGE)

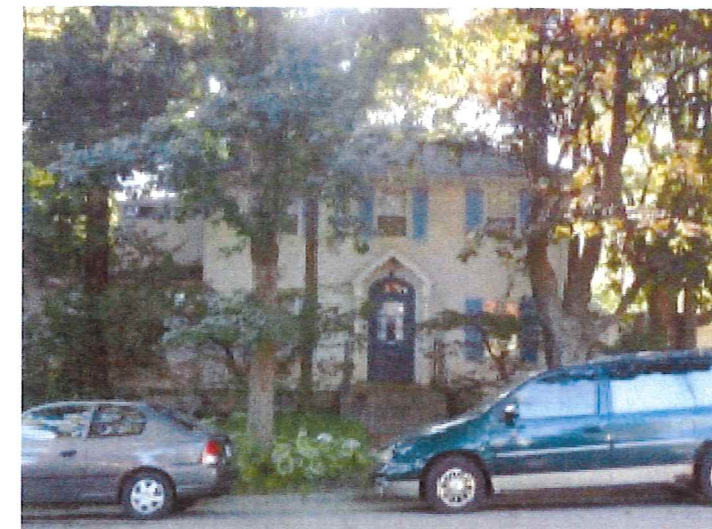

FRONT ELEVATION



207 N SPOONER ST



177 N PROSPECT

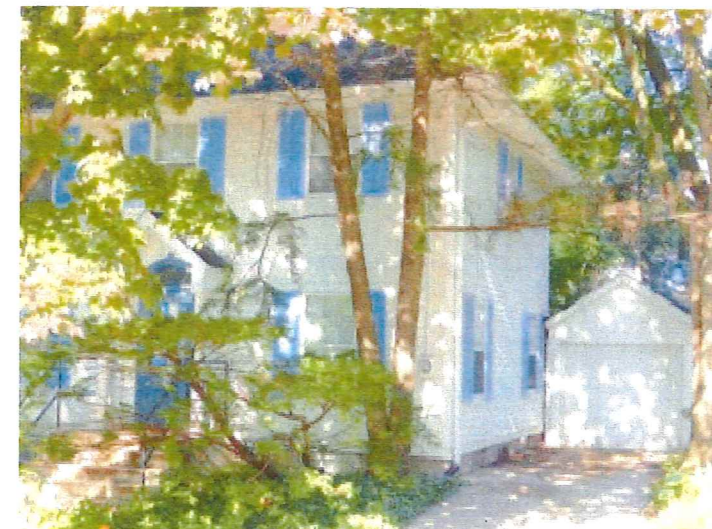

HOUSE GARAGE VIEW



211 N SPOONER ST



ARLINGTON PLACE  
(ROOM ABOVE GARAGE)



REAR ELEVATION

**2** NEIGHBORHOOD (ADJACENT HOUSE) PHOTOS

**1** SUBJECT HOUSE PHOTOS

REVISIONS

**KADUSHIN GARAGE ADDITION**

206 North Spooner Street  
Madison, WI 53726

Jeff Gaard - SZK Designs

1/4"=1'-0"

4/27/15

**G1**

00101