

# URBAN DESIGN COMMISSION APPLICATION

# UDC

City of Madison  
Planning Division  
Madison Municipal Building, Suite 017  
215 Martin Luther King, Jr. Blvd.  
P.O. Box 2985  
Madison, WI 53701-2985  
(608) 266-4635



## FOR OFFICE USE ONLY:

Date Received   3/2/26  11:28 a.m.

Initial Submittal

Paid

Revised Submittal

**Complete all sections of this application, including the desired meeting date and the action requested.** If your project requires both UDC and Land Use application submittals, a completed [Land Use Application](#) and accompanying submittal materials are also required to be submitted.

*If you need an interpreter, translator, materials in alternate formats or other accommodations to access these forms, please call the Planning Division at (608) 266-4635.*

*Si necesita interprete, traductor, materiales en diferentes formatos, u otro tipo de ayuda para acceder a estos formularios, por favor llame al (608) 266-4635.*

*Yog tias koj xav tau ib tug neeg txhais lus, tus neeg txhais ntawv, los sis xav tau cov ntaub ntawv ua lwm hom ntawv los sis lwm cov kev pab kom paub txog cov lus qhia no, thov hu rau Koog Npaj (Planning Division) (608) 266-4635.*

## 1. Project Information

Address (list all addresses on the project site): \_\_\_\_\_

Title: \_\_\_\_\_

## 2. Application Type (check all that apply) and Requested Date

UDC meeting date requested \_\_\_\_\_

New development

Alteration to an existing or previously-approved development

Informational

Initial Approval

Final Approval

## 3. Project Type

Project in an Urban Design District

Project in the Downtown Core District (DC), Urban Mixed-Use District (UMX), or Mixed-Use Center District (MXC)

Project in the Suburban Employment Center District (SEC), Campus Institutional District (CI), or Employment Campus District (EC)

Planned Development (PD)

General Development Plan (GDP)

Specific Implementation Plan (SIP)

Planned Multi-Use Site or Residential Building Complex

### Signage

Comprehensive Design Review (CDR)

Modifications of Height, Area, and Setback

Sign Exceptions as noted in [Sec. 31.043\(3\)](#), MGO

### Other

Please specify

\_\_\_\_\_

## 4. Applicant, Agent, and Property Owner Information

**Applicant name** \_\_\_\_\_

Company \_\_\_\_\_

Street address \_\_\_\_\_

City/State/Zip \_\_\_\_\_

Telephone \_\_\_\_\_

Email \_\_\_\_\_

**Project contact person** \_\_\_\_\_

Company \_\_\_\_\_

Street address \_\_\_\_\_

City/State/Zip \_\_\_\_\_

Telephone \_\_\_\_\_

Email \_\_\_\_\_

**Property owner (if not applicant)** \_\_\_\_\_

Street address \_\_\_\_\_

City/State/Zip \_\_\_\_\_

Telephone \_\_\_\_\_

Email \_\_\_\_\_

## Introduction

The City of Madison's Urban Design Commission (UDC) has been created to:

- Encourage and promote high quality in the design of new buildings, developments, remodeling, and additions so as to maintain and improve the established standards of property values within the City.
- Foster civic pride in the beauty and nobler assets of the City, and in all other ways possible assure a functionally efficient and visually attractive City in the future.

## Types of Approvals

There are three types of requests considered by the UDC:

- Informational Presentation. A request for an Informational Presentation to the UDC may be requested prior to seeking any approvals to obtain early feedback and direction before undertaking detailed design efforts. Applicants should provide details on the context of the site, design concept, site and building plans, and other relevant information to help the UDC understand the proposal and provide feedback. (Does not apply to CDR's or Signage Modification requests)
- Initial Approval. Applicants may, at their discretion, request Initial Approval of a proposal by presenting preliminary design information. As part of their review, the Commission will provide feedback on the design information that should be addressed at Final Approval stage.
- Final Approval. Applicants may request Final Approval of a proposal by presenting all final project details. Recommendations or concerns expressed by the UDC in the Initial Approval must be addressed at this time.

## Presentations to the Commission

The Urban Design Commission meets virtually via Zoom, typically on the second and fourth Wednesdays of each month at 4:30 p.m. Applicant presentations are strongly encouraged, although not required. Prior to the meeting, each individual speaker is required to complete an online registration form to speak at the meeting. A link to complete the online registration will be provided by staff prior to the meeting. Please note that individual presentations will be limited to a **maximum of three (3) minutes**. The pooling of time may be utilized to provide one speaker more time to present, however the additional time will be based on the number of registrants from the applicant team, i.e. two (2) applicant registrants = six (6) minutes for one (1) speaker.

Primarily, the UDC is interested in the appearance and design quality of projects. Emphasis should be given to the site plan, landscape plan, lighting plan, building elevations, exterior building materials, color scheme, and graphics. Please note that presentation slides, in a PDF file format, are required to be submitted **the Friday before** the UDC meeting.

# URBAN DESIGN DEVELOPMENT PLANS CHECKLIST

The items listed below are minimum application requirements for the type of approval indicated. Please note that the UDC and/or staff may require additional information in order to have a complete understanding of the project.

## 1. Informational Presentation

- Locator Map
- Letter of Intent (If the project is within an Urban Design District, a summary of how the development proposal addresses the district criteria is required)
- Contextual site information, including photographs and layout of adjacent buildings/structures
- Site Plan
- Two-dimensional (2D) images of proposed buildings or structures.

Providing additional information beyond these minimums may generate a greater level of feedback from the Commission.

### Requirements for All Plan Sheets

1. Title block
2. Sheet number
3. North arrow
4. Scale, both written and graphic
5. Date
6. Fully dimensioned plans, scaled at 1"= 40' or larger

*\*\* All plans must be legible, including the full-sized landscape and lighting plans (if required)*

## 2. Initial Approval

- Locator Map
- Letter of Intent (If the project is within a Urban Design District, a summary of how the development proposal addresses the district criteria is required)
- Contextual site information, including photographs and layout of adjacent buildings/structures
- Site Plan showing location of existing and proposed buildings, walks, drives, bike lanes, bike parking, and existing trees over 18" diameter
- Landscape Plan and Plant List (*must be legible*)
- Building Elevations in **both** black & white and color for all building sides, including material and color callouts
- PD text and Letter of Intent (if applicable)

Providing additional information beyond these minimums may generate a greater level of feedback from the Commission.

## 3. Final Approval

All the requirements of the Initial Approval (see above), **plus**:

- Grading Plan
- Lighting Plan, including fixture cut sheets and photometrics plan (must be legible)
- Utility/HVAC equipment location and screening details (with a rooftop plan if roof-mounted)
- Site Plan showing site amenities, fencing, trash, bike parking, etc. (if applicable)
- PD text and Letter of Intent (if applicable)
- Samples of the exterior building materials
- Proposed sign areas and types (if applicable)

## 4. Signage Approval (*Comprehensive Design Review (CDR), Sign Modifications, and Sign Exceptions (per [Sec. 31.043\(3\)](#))*)

- Locator Map
- Letter of Intent (a summary of how the proposed signage is consistent with the CDR or Signage Modifications criteria is required)
- Contextual site information, including photographs of existing signage both on site and within proximity to the project site
- Site Plan showing the location of existing signage and proposed signage, dimensioned signage setbacks, sidewalks, driveways, and right-of-ways
- Proposed signage graphics (fully dimensioned, scaled drawings, including materials and colors, and night view)
- Perspective renderings (emphasis on pedestrian/automobile scale viewsheds)
- Illustration of the proposed signage that meets [Ch. 31, MGO](#) compared to what is being requested
- Graphic of the proposed signage as it relates to what the [Ch. 31, MGO](#) would permit

**5. Required Submittal Materials**

**Application Form**

- A completed application form is required for each UDC appearance. For projects also requiring Plan Commission approval, applicants must also have submitted an accepted application for Plan Commission consideration prior to obtaining any formal action (Initial or Final Approval) from the UDC.

**Letter of Intent**

- If the project is within an Urban Design District, a summary of how the development proposal addresses the district criteria is required.
- For signage applications, a summary of how the proposed signage is consistent with the applicable Comprehensive Design Review (CDR) or Signage Modification review criteria is required.

**Development Plans** (Refer to checklist on Page 4 for plan details)

**Filing Fee** (Refer to Section 7 (below) for a list of application fees by request type)

**Electronic Submittal**

- Complete electronic submittals must be received prior to the application deadline before an application will be scheduled for a UDC meeting. Late materials will not be accepted. All plans must be legible and scalable when reduced. Individual PDF files of each item submitted should be submitted via email to [UDCapplications@cityofmadison.com](mailto:UDCapplications@cityofmadison.com). The email must include the project address, project name, and applicant name.
- Email Size Limits. Note that an individual email cannot exceed 20MB and it is the responsibility of the applicant to present files in a manner that can be accepted. Applicants who are unable to provide the materials electronically should contact the Planning Division at (608) 266-4635 for assistance.

**Notification to the District Alder**

- Please provide an email to the District Alder notifying them that you are filing this UDC application. Please send this as early in the process as possible and provide a copy of that email with the submitted application.

**6. Applicant Declarations**

1. Prior to submitting this application, the applicant is required to discuss the proposed project with Urban Design Commission staff. This application was discussed with \_\_\_\_\_ on \_\_\_\_\_.
2. The applicant attests that all required materials are included in this submittal and understands that if any required information is not provided by the application deadline, the application will not be placed on an Urban Design Commission agenda for consideration.

Name of applicant \_\_\_\_\_ Relationship to property \_\_\_\_\_

Authorizing signature of property owner  \_\_\_\_\_ Date \_\_\_\_\_

**7. Application Filing Fees**

Fee payments are due by the submittal date. Payments received after the submittal deadline may result in the submittal being scheduled for the next application review cycle. Fees may be paid in-person, via US Mail, or City drop box. If mailed, please mail to: *City of Madison Building Inspection, P.O. Box 2984, Madison, WI 53701-2984*. The City's drop box is located outside the Municipal Building at 215 Martin Luther King, Jr. Blvd. on the E Doty Street side of the building. Please make checks payable to *City Treasurer*, and include a completed application form or cover letter indicating the project location and applicant information with all checks mailed or submitted via the City's drop box.

Please consult the schedule below for the appropriate fee for your request:

Urban Design Districts: \$350 (per [§33.24\(6\) MGO](#)).

Minor Alteration in the Downtown Core District (DC) or Urban Mixed-Use District (UMX) : \$150 (per [§33.24\(6\)\(b\) MGO](#))

Comprehensive Design Review: \$500 (per [§31.041\(3\)\(d\)\(1\)\(a\) MGO](#))

Minor Alteration to a Comprehensive Sign Plan: \$100 (per [§31.041\(3\)\(d\)\(1\)\(c\) MGO](#))

All other sign requests to the Urban Design Commission, including, but not limited to: appeals from the decisions of the Zoning Administrator, requests for Sign Modifications (of height, area, and setback), and additional sign code approvals: \$300 (per [§31.041\(3\)\(d\)\(2\) MGO](#))

A filing fee is not required for the following project applications if part of the combined application process involving both Urban Design Commission and Plan Commission:

- Project in the Downtown Core District (DC), Urban Mixed-Use District (UMX), or Mixed-Use Center District (MXC)
- Project in the Suburban Employment Center District (SEC), Campus Institutional District (CI), or Employment Campus District (EC)
- Planned Development (PD): General Development Plan (GDP) and/or Specific Implementation Plan (SIP)
- Planned Multi-Use Site or Residential Building Complex



March 2, 2026

RE: 4701 Mineral Point Road; UDC/PC Application Revision

On behalf of Galway Companies, we are submitting revisions to the previous submittal. Due to circumstances, Raising Canes will not be the tenant of the proposed building. The proposed will consist of up to three tenants. A drive-thru will remain for a single tenant. As a dual lane configuration, stacking allows up to 14 vehicles for queuing. The drive-thru design has been reconfigured to be separate from the parking area as previously designed to aid in pedestrian safety.

Additional site considerations include 32 parking spaces adjacent to the proposed having 2 accessible stalls. 4 bike stalls are provided with direct access to Mineral Point Road public sidewalk. A patio remains part of the project for any tenant that requires.

The building remains as a two-story structure with overbuilt canopy per the TOD overlay district with a minimum of 75% of the first floor area including the drive-thru canopy. A separate stairs and elevator located on the east side of the building provided access to the second floor. Exterior materials have been adjusted to include a mix of fiber cement panels and styles, colors, in addition to masonry accents surrounding the entrances and transitions to grade. Glazed openings along Mineral Point Road exceed the 60% of lineal foot and 40% area requirement.

Please accept the included revisions to the 7401 Mineral Point Road development.

Respectfully,

A handwritten signature in blue ink that reads "Bradley S. Koning". The signature is written in a cursive, flowing style.

Brad Koning, AIA.  
Sketchworks Architecture, LLC



# City of Madison Fire Department

314 W Dayton Street, Madison, WI 53703  
 Phone: 608-266-4420 • Fax: 608-267-1100 • E-mail: fire@cityofmadison.com

<b>Project Address:</b>	7401 Mineral Point Rd. Madison, WI 53717
<b>Contact Name &amp; Phone #:</b>	Brad Koning (Sketchworks Architecture) 608.836.7570

## FIRE APPARATUS ACCESS AND FIRE HYDRANT WORKSHEET

1. Is the building completely protected by an NFPA 13 or 13R automatic fire sprinkler system? <b>If non-sprinklered</b> , fire lanes extend to within 150-feet of all portions of the exterior wall? <b>If sprinklered</b> , fire lanes are within 250-feet of all portions of the exterior wall?	<input checked="" type="checkbox"/> Yes <input type="checkbox"/> Yes <input checked="" type="checkbox"/> Yes	<input type="checkbox"/> No <input type="checkbox"/> No <input type="checkbox"/> No	<input type="checkbox"/> N/A <input checked="" type="checkbox"/> N/A <input type="checkbox"/> N/A
2. Is the fire lane constructed of concrete or asphalt, designed to support a minimum load of 85,000 lbs? a) Is the fire lane a minimum unobstructed width of at least 20-feet? b) Is the fire lane unobstructed with a vertical clearance of at least 13½-feet? c) Is the minimum inside turning radius of the fire lane at least 28-feet? d) Is the grade of the fire lane not more than a slope of 8%? e) Is the fire lane posted as fire lane? (Provide detail of signage.) f) Is a roll-able curb used as part of the fire lane? (Provide detail of curb.) g) Is part of a sidewalk used as part of the required fire lane? (Must support +85,000 lbs.)	<input checked="" type="checkbox"/> Yes <input checked="" type="checkbox"/> Yes <input checked="" type="checkbox"/> Yes <input checked="" type="checkbox"/> Yes <input type="checkbox"/> Yes <input type="checkbox"/> Yes <input type="checkbox"/> Yes	<input type="checkbox"/> No <input type="checkbox"/> No <input type="checkbox"/> No <input type="checkbox"/> No <input type="checkbox"/> No <input checked="" type="checkbox"/> No <input checked="" type="checkbox"/> No <input checked="" type="checkbox"/> No	<input type="checkbox"/> N/A <input type="checkbox"/> N/A <input type="checkbox"/> N/A <input type="checkbox"/> N/A <input type="checkbox"/> N/A <input type="checkbox"/> N/A <input type="checkbox"/> N/A
3. Is the fire lane obstructed by security gates or barricades? If yes: a) Is the gate a minimum of 20-feet clear opening? b) Is an approved means of emergency operations installed, key vault, padlock or key switch?	<input type="checkbox"/> Yes <input type="checkbox"/> Yes <input type="checkbox"/> Yes	<input checked="" type="checkbox"/> No <input type="checkbox"/> No <input type="checkbox"/> No	<input type="checkbox"/> N/A <input type="checkbox"/> N/A <input type="checkbox"/> N/A
4. Is the Fire lane dead-ended with a length greater than 150-feet? If yes, does the area for turning around fire apparatus comply with IFC D103?	<input type="checkbox"/> Yes <input type="checkbox"/> Yes	<input checked="" type="checkbox"/> No <input type="checkbox"/> No	<input type="checkbox"/> N/A <input type="checkbox"/> N/A
5. Is any portion of the building to be used for high-piled storage in accordance with IFC Chapter 3206.6 If yes, see IFC 3206.6 for further requirements.	<input type="checkbox"/> Yes	<input checked="" type="checkbox"/> No	<input type="checkbox"/> N/A
6. Is any part of the building <u>greater than 30-feet</u> above the grade plane? If yes, answer the following questions: a) Is the aerial apparatus fire lane parallel to one entire side of the building and covering at least 25% of the perimeter? b) Is the near edge of the aerial apparatus fire lane between 15' and 30' from the building? c) Are there any overhead power or utility lines located across the aerial apparatus fire lane? d) Are there any tree canopies expected to grow across the aerial fire lane? (Based on mature canopy width of tree species) e) Does the aerial apparatus fire lane have a minimum unobstructed width of 26-feet? f) Is the space between the aerial lane and the building free of trees exceeding 20' in heights?	<input type="checkbox"/> Yes <input type="checkbox"/> Yes <input type="checkbox"/> Yes <input type="checkbox"/> Yes <input type="checkbox"/> Yes <input type="checkbox"/> Yes	<input checked="" type="checkbox"/> No <input type="checkbox"/> No <input type="checkbox"/> No <input type="checkbox"/> No <input type="checkbox"/> No <input type="checkbox"/> No	<input type="checkbox"/> N/A <input checked="" type="checkbox"/> N/A <input checked="" type="checkbox"/> N/A <input checked="" type="checkbox"/> N/A <input checked="" type="checkbox"/> N/A <input checked="" type="checkbox"/> N/A
7. Are all portions of the required fire lanes within 500-feet of at least (2) hydrants? <i>Note: Distances shall be measured along the path of the hose lay as it comes off the fire apparatus.</i> a) Is the fire lane at least 26' wide for at least 20-feet on each side of the hydrants? b) Is there at least 40' between a hydrant and the building? c) Are the hydrant(s) setback no less than 5-feet nor more than 10-feet from the curb or edge of the street or fire lane? d) Are hydrants located in parking lot islands a minimum of 3½-feet from the hydrant to the curb? e) Are there no obstructions, including but not limited to: power poles, trees, bushes, fences, posts located, or grade changes exceeding 1½-feet, within 5-feet of a fire hydrant?	<input checked="" type="checkbox"/> Yes <input checked="" type="checkbox"/> Yes <input checked="" type="checkbox"/> Yes <input checked="" type="checkbox"/> Yes <input checked="" type="checkbox"/> Yes	<input type="checkbox"/> No <input type="checkbox"/> No <input type="checkbox"/> No <input type="checkbox"/> No <input type="checkbox"/> No	<input type="checkbox"/> N/A <input type="checkbox"/> N/A <input type="checkbox"/> N/A <input type="checkbox"/> N/A <input type="checkbox"/> N/A

*Note: Hydrants shall be installed and in-service prior to combustible construction on the project site.*

Attach an additional sheet if further explanation is required for any answers.

This worksheet is based on **MGO 34.503** and **IFC 2021 Edition Chapter 5 and Appendix D**; please see the codes for further information.

PROJECT NAME: \_\_\_\_\_ QUANTITY: \_\_\_\_\_ TYPE: \_\_\_\_\_

ORDERING CODE: \_\_\_\_\_

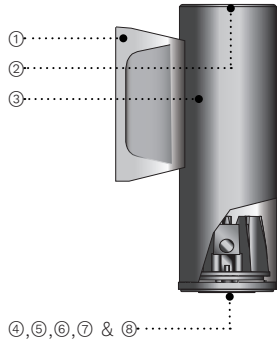

- ① Cast aluminum driver housing, includes galvanized steel wall mount pressure plate.
- ② Cast aluminum top cover.
- ③ Extruded aluminum cylindrical housing.
- ④ Fully sealed cast aluminum light assembly.
- ⑤ Sealed cast aluminum lens frame.
- ⑥ Clear tempered glass lens.
- ⑦ Faceted specular aluminum reflector.
- ⑧ All stainless steel hardware.



SY300



## MATERIALS

Syrios is made of corrosion resistant 356 aluminum alloy with a copper (CU) content of less than 0.1%. The main housing is made of seamless extruded aluminum, with an integrally sealed LED light module designed for optimal heat dissipation, and lighting performance.

## ELECTRICAL DRIVER

Driver is 0-10V dimming-ready (dims to 10%) with: 120-277 multi-volt compatibility (50-60Hz), operating temperature range of -30°C/-22°F to 55°C/131°F, output over voltage protection, output over current protection and output short circuit protection with auto-recovery.

## LED LIGHT ENGINE

Offered in 2700K/3000K/3500K/4000K CCT with 80 CRI. 70% LED lumen maintenance at 60,000 hours (L70/B50) based on IESNA LM-80-08 LED extrapolated life, calculated per IESNA TM-21-21. Optional true amber LED for turtle sensitive areas. Wavelengths: 585nm to 597nm.

## FINISH

Five-stage preparation process including preheating of cast aluminum parts for air extraction, and an environmentally friendly alloy sealant. Polyester powder coating is applied through an electrostatic process and oven cured for long term finish.

## CERTIFICATION

UL Certified to Canadian and U.S. safety standards. Certified for use in wet locations. Rated IP65. Photometric testing performed by an independent laboratory in accordance with IES LM-79-08 standards at 25°C. Actual performance may differ as a result of end-user environment and application.

## WARRANTY

5-year limited warranty. This is the only warranty provided and no other statements in this specification sheet create any warranty of any kind. All other express and implied warranties are disclaimed. Complete warranty terms located at: <https://www.acuitybrands.com/support/warranty/terms-and-conditions>

## MOUNTING

The mounting plate is designed to fit on a 2X4" (51x102mm) rectangular electrical box using 3.156" (80mm) C/C mounting holes. Optional trimming plate for octagonal jbox (option MT4).

## MEASUREMENTS

Maximum weight: 2.5 lbs (1.1 kg)

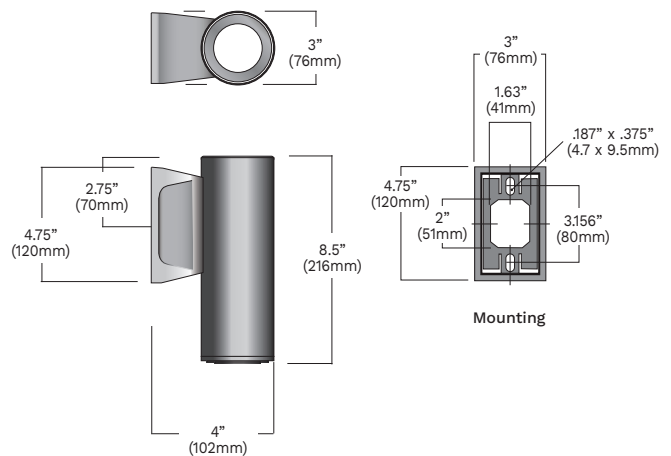

ORDERING CODE

*SERIES	*LIGHT OUTPUT	*DISTRIBUTION	*CCT <sup>4</sup>	*VOLTAGE	CONDUIT COVER
<b>SY300</b> 	<u>Static White</u> <b>L1L10</b> 924 lm / 13w <sup>1</sup>  <u>True Amber</u> <b>L1LK2A</b> 124 lm / 7w <sup>1</sup>  Delivered lumens calculated at 4000K/80CRI except for amber. Flood optic distribution. Typical power consumption. Refer to LCF table for outputs at other CCTs.	<b>FLD</b> Flood optic 29° <b>WD</b> Wide optic 42°	<b>27K</b> 2700K <b>30K</b> 3000K <b>35K</b> 3500K <b>40K</b> 4000K <b>AMB</b> 585nm to 597nm	<b>120</b> 120V <b>277</b> 277V <b>MVOLT</b> 120V-277V	<b>SWK</b> Decorative cover for 3/4" conduit junction box <sup>5</sup>
	<u>Very Narrow Distribution</u> <b>L1L5NR</b> 539 lm / 10w <sup>2</sup>  Delivered lumens calculated at 4000K/80CRI. Very narrow optic distribution. Typical power consumption. Refer to LCF table for outputs at other CCTs.	<b>VNR</b> Very narrow optic 9° <sup>3</sup>			

MOUNTING ACCESSORY	MOUNTING DIRECTION	LENS/DIFFUSER	FUSE	EMERGENCY
<b>MT4</b> Trim plate for 4" octagonal J-box	<b>UP</b> Uplight position	<b>LSL</b> Linear spread lens <b>SL</b> Solite lens <sup>6</sup>	<b>FS</b> Fuse	<b>REM7</b> Remote emergency battery, 90 min, 7W <sup>7</sup>

SHIELDING ACCESSORIES	LOUVERS	*FINISH	WOOD FINISH <sup>11</sup>	ENVIRONMENT	HEIGHT MATCHING
<b>SNT</b> Snoot <sup>8</sup>	<b>HL</b> Hexcell louver	<b>BKT</b> Jet black <b>BZT</b> Bronze <b>CHT</b> Champagne <b>CNT</b> Corten <b>DGT</b> Gun metal <b>GRT</b> Titanium gray <b>MST</b> Matte silver <b>SGT</b> Steel gray <b>WHT</b> Snow white  <b>CMC</b> Custom matched color <sup>9</sup> <b>RAL</b> RAL color <sup>10</sup>	<b>ADG</b> American douglas <b>BRC</b> Birch <b>CHN</b> Chestnut <b>CRY</b> Cherry <b>KNP</b> Knotty pine <b>MPL</b> Maple <b>OFL</b> Oak <b>RSW</b> Rosewood <b>TEK</b> Teak <b>WLN</b> Walnut	<b>MG</b> Marine grade paint <sup>12</sup> <b>NT</b> Natatorium suitable <sup>13</sup>	<b>UH</b> Uniform height matching SY302

NOTES

- \*- Denotes a required field
- 1- Available only with AMB option.
- 2- Available only with VNR distribution option. Not available with 27K, 35K or AMB.
- 3- Field angle 21°.
- 4- For IDA certification compliance, luminaire must be ordered with 3000K or warmer.
- 5- Not available with MT4. Painted to match fixture color.
- 6- Lumen conversion factor (LCF) 0.9.
- 7- Remote mount 50ft - 12" square enclosure with access cover. The remote enclosure must be interior. Cable between fixture and remote box is provided by others.
- 8- To prevent reflections, interior painted black when a light color finish is selected (ex. WHT, MST, GRT and CHT). 1.5" (38mm) snoot.
- 9- Contact factory to coordinate custom matching color.
- 10- Specify RAL number.
- 11- Faux wood finish not applied to driver housing, lens frame or accessories. Additional delay required. Not compatible with marine grade paint.
- 12- Marine grade paint for harsh, coastal environment and exposure to salt water. Additional delay required please contact factory for info.
- 13- Available only in WHT and BKT finish.

## TYPICAL PHOTOMETRY SUMMARY

SY300-L1L10-FLD

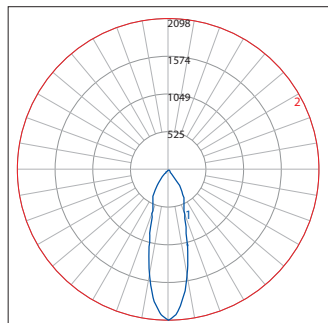

**Total Lms:** 924 Lumens  
**Total Input Watts:** 13 W  
**Efficacy:** 74 Lumens/Watt  
**BUG:** B1-U0-G0  
**CCT/CRI:** 4000K/80  
**Maximum Candela:** 2098 @ 0°

SY300-L1L10-WD

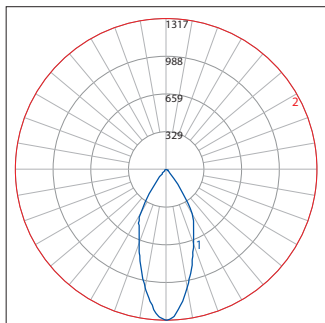

**Total Lms:** 846 Lumens  
**Total Input Watts:** 13 W  
**Efficacy:** 68 Lumens/Watt  
**BUG:** B1-U0-G0  
**CCT/CRI:** 4000K/80  
**Maximum Candela:** 1317 @ 0°

SY300-L1L5NR-VNR

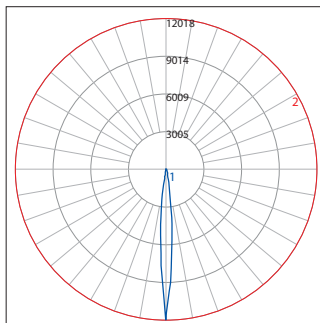

**Total Lms:** 539 Lumens  
**Total Input Watts:** 10 W  
**Efficacy:** 53 Lumens/Watt  
**BUG:** B1-U0-G0  
**CCT/CRI:** 4000K/80  
**Maximum Candela:** 12018 @ 0°

### LUMEN CONVERSION FACTOR (LCF)

CCT	CRI	LCF
2700K	80	0.91
3000K	80	0.94
3500K	80	0.98
4000K	80	1.00

All Photometry shown use the 80CRI 4000K LEDs.  
 Please visit our web site [www.luminis.com](http://www.luminis.com) for complete I.E.S. file.

## LUMINIS.COM

Toll free: (866) 586-4647 | Fax: (514) 683-8872 | Email: [info@luminis.com](mailto:info@luminis.com)  
 260 Labrosse, Pointe-Claire (QC) Canada H9R 5L5



# RSX1 LED Area Luminaire



Catalog Number
Notes
Type

Hit the Tab key or mouse over the page to see all interactive elements.

## Specifications

<b>EPA (ft<sup>2</sup>@0°):</b>	0.57 ft <sup>2</sup> (0.05 m <sup>2</sup> )
<b>Length:</b>	21.8" (55.4 cm) (SPA mount)
<b>Width:</b>	13.3" (33.8 cm)
<b>Height:</b>	3.0" (7.6 cm) Main Body 7.2" (18.4 cm) Arm
<b>Weight: (SPA mount):</b>	22.0 lbs (10.0 kg)

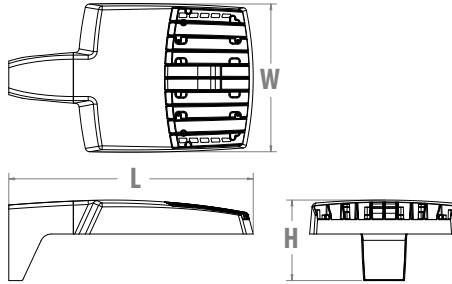

## Introduction

The new RSX LED Area family delivers maximum value by providing significant energy savings, long life and outstanding photometric performance at an affordable price. The RSX1 delivers 7,000 to 17,000 lumens allowing it to replace 70W to 400W HID luminaires.

The RSX features an integral universal mounting mechanism that allows the luminaire to be mounted on most existing drill hole patterns. This "no-drill" solution provides significant labor savings. An easy-access door on the bottom of mounting arm allows for wiring without opening the electrical compartment. A mast arm adaptor, adjustable integral slipfitter and other mounting configurations are available.



Items marked by a shaded background qualify for the Design Select program and ship in 15 days or less. To learn more about Design Select, visit [www.acuitybrands.com/designselect](http://www.acuitybrands.com/designselect).  
\*See ordering tree for details

ds Design Select options indicated by this color background.

## Ordering Information

## EXAMPLE: RSX1 LED P4 40K R3 MVOLT SPA DDBXD

Series	Performance Package	Color Temperature	Distribution	Voltage	Mounting
RSX1 LED	P1 P2 P3 P4	30K 3000K 40K 4000K 50K 5000K	R2 Type 2 Wide R3 Type 3 Wide R3S Type 3 Short R4 Type 4 Wide R4S Type 4 Short R5 Type 5 Wide <sup>1</sup> R5S Type 5 Short <sup>1</sup> AFR Automotive Front Row AFRR90 Automotive Front Row Right Rotated AFRL90 Automotive Front Row Left Rotated	MVOLT (120V-277V) <sup>2</sup> HVOLT (347V-480V) <sup>3</sup> XVOLT (277V-480V) <sup>4</sup>  (use specific voltage for options as noted) 120 <sup>5</sup> 277 <sup>5</sup> 208 <sup>5</sup> 347 <sup>5</sup> 240 <sup>5</sup> 480 <sup>5</sup>	SPA Square pole mounting (3.0" min. SQ pole for 1 at 90°, 3.5" min. SQ pole for 2, 3, 4 at 90°) RPA Round pole mounting (3.2" min. dia. RND pole for 2, 3, 4 at 90°, 3.0" min. dia. RND pole for 1 at 90°, 2 at 180°, 3 at 120°) MA Mast arm adaptor (fits 2-3/8" OD horizontal tenon) IS Adjustable slipfitter (fits 2-3/8" OD tenon) <sup>6</sup> WBA Wall bracket <sup>1</sup> WBASC Wall bracket with surface conduit box AASP Adjustable tilt arm square pole mounting <sup>6</sup> AARP Adjustable tilt arm round pole mounting <sup>6</sup> AAWB Adjustable tilt arm with wall bracket <sup>6</sup> AAWSC Adjustable tilt arm wall bracket and surface conduit box <sup>6</sup>

Options	Finish
<b>Shipped Installed</b> HS House-side shield <sup>7</sup> PE Photocontrol, button style <sup>8,9</sup> PER7 Seven-wire twist-lock receptacle only (no controls) <sup>9,10,11</sup> SF Single fuse (120, 277, 347) <sup>5</sup> DF Double fuse (208, 240, 480) <sup>5</sup> SPD20KV 20KV Surge pack (10KV standard) FAO Field adjustable output <sup>9</sup> DMG 0-10V dimming extend out back of housing for external control (control ordered separate) <sup>9</sup>	DDBXD Dark Bronze DBLXD Black DNAXD Natural Aluminum DWHXD White DDBTXD Textured Dark Bronze DBLBXD Textured Black DNATXD Textured Natural Aluminum DWHGXD Textured White
<b>Shipped Separately (requires some field assembly)</b> EGS External glare shield <sup>7</sup> EGFV External glare full visor (360° around light aperture) <sup>7</sup> BS Bird spikes <sup>16</sup>	

**Shipped Installed**  
 \*Standalone and Networked Sensors/Controls (factory default settings, see table page 9)  
 NLTAIR2 PIRHN nLight AIR generation 2, with Networked, Bi-Level motion/ambient sensor<sup>9,12,13,14</sup>  
 BAA Buy America(n) Act and/or Build America Buy America Qualified  
 CCE Coastal Construction<sup>15</sup>  
 \*Note: NLTAIR2 PIRHN with nLight Air can be used as a standalone or networked solution. Sensor coverage pattern is affected when luminaire is tilted.



## Ordering Information

### Accessories

Ordered and shipped separately.

RSX1HS	RSX1 House side shield (includes 1 shield)
RSX1HSAFRR U	RSX1 House side shield for AFR rotated optics (includes 1 shield)
RSX1EGS (FINISH) U	External glare shield (specify finish)
RSX1EGFV (FINISH) U	External glare full visor (specify finish)
RSXRPA (FINISH) U	RSX Universal round pole adaptor plate (specify finish)
RSXWBA (FINISH) U	RSX WBA wall bracket (specify finish) <sup>1</sup>
RSXSGB (FINISH) U	RSX Surface conduit box (specify finish, for use with WBA, WBA not included)
DLL127F 1.5 JU	Photocell -SSL twist-lock (120-277V) <sup>17</sup>
DLL347F 1.5 CUL JU	Photocell -SSL twist-lock (347V) <sup>17</sup>
DLL480F 1.5 CUL JU	Photocell -SSL twist-lock (480V) <sup>17</sup>
DSHORT SBK U	Shorting cap <sup>17</sup>

### NOTES

- Type 5 distribution is not available with WBA.
- MVOLT driver operates on any line voltage from 120-277V (50/60 Hz).
- HVOLT driver operates on any line voltage from 347-480V (50/60 Hz).
- XVOLT driver not available with P1 or P2. XVOLT driver operates on any line voltage from 277V-480V (50/60 Hz). XVOLT not available with fusing (SF or DF) and not available with PE.
- Single fuse (SF) requires 120V, 277V or 347V. Double fuse (DF) requires 208V, 240V or 480V.
- Maximum tilt is 90° above horizontal.
- It may be ordered as an accessory.
- Requires MVOLT or 347V.
- Two or more of the following options cannot be combined including PE, DMG, PER7, FAO and NLTAIR2 PIRHN. (Exception: PE and FAO can be combined; also PE and DMG can be combined.)
- Compatible with standard twist-lock photocells for dusk to dawn operation or advanced control nodes that provide 0-10V dimming

- signals. Wire 4/Wire 5 wired to dimming leads on driver. Wire6/Wire7 capped inside luminaire. Twistlock photocell ordered and shipped as a separate line item from Acuity Brands Controls. See accessories. Shorting Cap included.
- For units with option PER7, the mounting must be restricted to +/- 45° from horizontal aim per ANSI C136.10-2010.
  - Must be ordered with PIRHN.
  - Requires MVOLT or HVOLT.
  - Must be ordered with NLTAIR2. For additional information on PIRHN visit [here](#).
  - CCE option not available with WBA, WBASC, AASP, AARP, AAWB, AAWBSC, EGS, EGFV and BS.
  - Must be ordered with fixture for factory pre-drilling.
  - Requires luminaire to be specified with PER7 option. Ordered and shipped as a separate line item from Acuity Brands Controls.

## External Shields



House Side Shield



External Glare Shield



External 360 Full Visor

## Pole/Mounting Information

Accessories including bullhorns, cross arms and other adapters are available under the accessories tab at Lithonia's Outdoor Poles and Arms product page. Click here to visit [Accessories](#).

### HANDHOLE ORIENTATION

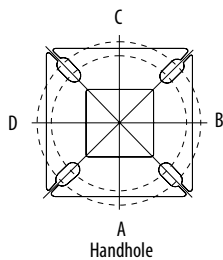

### RSX POLE DRILLING

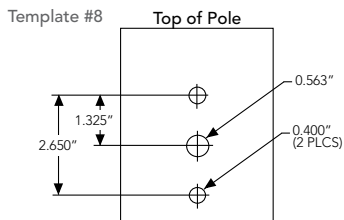

### RSX STANDARD ARM & ADJUSTABLE ARM

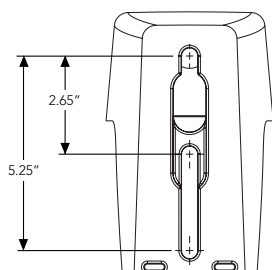

### Round Tenon Mount - Pole Top Slipfitters

Tenon O.D.	RSX Mounting	Single	2 @ 180°	2 @ 90°	3 @ 120°	3 @ 90°	4 @ 90°
2 - 3/8"	RPA, AARP	AS3-5 190	AS3-5 280	AS3-5 290	AS3-5 320	AS3-5 390	AS3-5 490
2 - 7/8"	RPA, AARP	AST25-190	AST25-280	AST25-290	AST25-320	AST25-390	AST25-490
4"	RPA, AARP	AST35-190	AST35-280	AST35-290	AST35-320	AST35-390	AST35-490

### Drill/Side Location by Configuration Type

Drilling Template	Mounting Option	Single	2 @ 180	2 @ 90	3 @ 120	3 @ 90	4 @ 90
#8	Head Location	Side B	Side B & D	Side B & C	Round Pole Only	Side B, C & D	Side A, B, C & D
#8	Drill Nomenclature	DM19AS	DM28AS	DM29AS	DM32AS	DM39AS	DM49AS

### RSX1 - Luminaire EPA

\*Includes luminaire and integral mounting arm. Other tenons, arms, brackets or other accessories are not included in this EPA data.

Fixture Quantity & Mounting Configuration	Single	2 @ 90	2 @ 180	3 @ 90	3 @ 120	4 @ 90	2 Side by Side	3 Side by Side	4 Side by Side
<b>SPA - Square Pole Adaptor</b>	0.57	1.03	1.05	1.52	1.36	2.03	1.31	1.7	2.26
<b>RPA - Round Pole Adaptor</b>	0.62	1.08	1.15	1.62	1.46	2.13	1.36	1.8	2.36
<b>MA - Mast Arm Adaptor</b>	0.49	0.95	0.89	1.36	1.2	1.87	1.23	1.54	2.1
<b>IS - Integral Slipfitter</b>	0.57	1.03	1.05	1.52	1.36	2.03	1.31	1.7	2.26
<b>AASP/AARP - Adjustable Arm Square/Round Pole</b>	0.62	1.08	1.15	1.62	1.46	2.13	1.36	1.8	2.36
	0°	0.57	1.03	1.05	1.52	1.36	2.03	1.31	2.26
	10°	0.68	1.34	1.33	2	1.74	2.64	1.35	2.03
	20°	0.87	1.71	1.73	2.56	2.26	3.42	1.75	2.62
	30°	1.24	2.19	2.3	3.21	2.87	4.36	2.49	3.73
	40°	1.81	2.68	2.98	3.85	3.68	5.30	3.62	5.43
	45°	2.11	2.92	3.44	4.2	4.08	5.77	4.22	6.33
	50°	2.31	3.17	3.72	4.52	4.44	6.26	4.62	6.94
	60°	2.71	3.66	4.38	5.21	5.15	7.24	5.43	8.14
	70°	2.78	3.98	4.54	5.67	5.47	7.91	5.52	8.27
	80°	2.76	4.18	4.62	5.97	5.76	8.31	5.51	8.27
	90°	2.73	4.25	4.64	6.11	5.91	8.47	5.45	8.18

Isofootcandle plots for the RSX1 LED P4 40K. Distances are in units of mounting height (20').

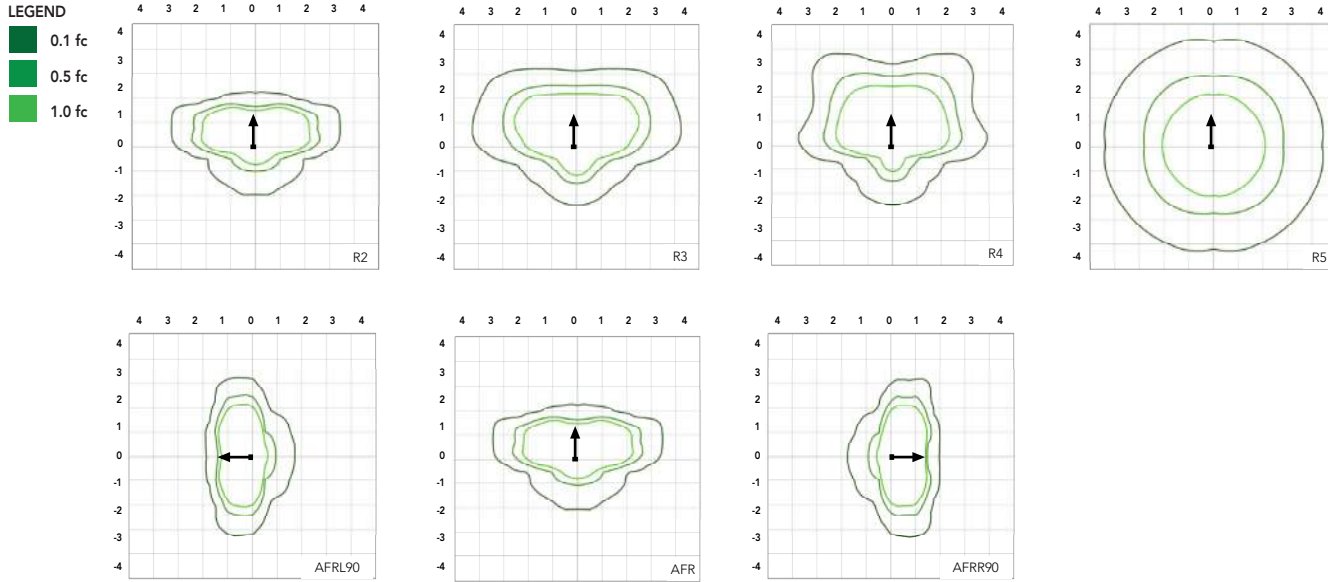

## Performance Data

### Lumen Ambient Temperature (LAT) Multipliers

Use these factors to determine relative lumen output for average ambient temperatures from 0-50°C (32-122°F).

Ambient	Ambient	Lumen Multiplier
0°C	32°F	1.05
5°C	41°F	1.04
10°C	50°F	1.03
15°C	59°F	1.02
20°C	68°F	1.01
25°C	77°F	1.00
30°C	86°F	0.99
35°C	95°F	0.98
40°C	104°F	0.97
45°C	113°F	0.96
50°C	122°F	0.95

### Electrical Load

Performance Package	System Watts (W)	Current (A)					
		120V	208V	240V	277V	347V	480V
P1	51W	0.42	0.25	0.21	0.19	0.14	0.11
P2	72W	0.60	0.35	0.30	0.26	0.21	0.15
P3	109W	0.91	0.52	0.45	0.39	0.31	0.23
P4	133W	1.11	0.64	0.55	0.48	0.38	0.27

### Projected LED Lumen Maintenance

Operating Hours	50,000	75,000	100,000
Lumen Maintenance Factor	>0.97	>0.95	>0.92

Values calculated according to IESNA TM-21-11 methodology and valid up to 40°C.

Lumen Output

Lumen values are from photometric tests performed in accordance with IESNA LM-79-08. Data is considered to be representative of the configurations shown, within the tolerances allowed by Lighting Facts. Contact factory for performance data on any configurations not shown here.

Performance Package	System Watts	Distribution Type	30K (3000K, 70 CRI)					40K (4000K, 70 CRI)					50K (5000K, 70 CRI)				
			Lumens	B	U	G	LPW	Lumens	B	U	G	LPW	Lumens	B	U	G	LPW
P1	51W	R2	6,482	1	0	1	126	7,121	1	0	1	139	7,121	1	0	1	139
		R3	6,459	1	0	2	127	7,096	1	0	2	139	7,096	1	0	2	139
		R35	6,631	1	0	1	129	7,286	1	0	2	142	7,286	1	0	2	142
		R4	6,543	1	0	2	128	7,189	1	0	2	141	7,189	1	0	2	141
		R45	6,313	1	0	1	124	6,936	1	0	1	136	6,936	1	0	1	136
		R5	6,631	3	0	2	130	7,286	3	0	2	143	7,286	3	0	2	143
		R55	6,807	3	0	1	133	7,479	3	0	1	147	7,479	3	0	1	147
		AFR	6,473	1	0	1	127	7,112	1	0	1	139	7,112	1	0	1	139
		AFRR90	6,535	2	0	2	127	7,179	2	0	2	140	7,179	2	0	2	140
AFRL90	6,562	2	0	1	128	7,210	2	0	2	140	7,210	2	0	2	140		
P2	72W	R2	8,991	2	0	1	123	9,878	2	0	1	135	9,878	2	0	1	135
		R3	8,959	2	0	2	124	9,843	2	0	2	137	9,843	2	0	2	137
		R35	9,198	2	0	2	126	10,106	2	0	2	139	10,106	2	0	2	139
		R4	9,077	2	0	2	126	9,972	2	0	2	139	9,972	2	0	2	139
		R45	8,757	1	0	2	122	9,622	2	0	2	134	9,622	2	0	2	134
		R5	9,198	4	0	2	128	10,106	4	0	2	140	10,106	4	0	2	140
		R55	9,443	3	0	1	131	10,374	3	0	1	144	10,374	3	0	1	144
		AFR	8,979	2	0	1	125	9,865	2	0	1	137	9,865	2	0	1	137
		AFRR90	9,064	3	0	2	124	9,959	3	0	2	137	9,959	3	0	2	137
AFRL90	9,102	3	0	2	125	10,001	3	0	2	137	10,001	3	0	2	137		
P3	109W	R2	12,808	2	0	1	117	14,072	2	0	2	129	14,072	2	0	2	129
		R3	12,763	2	0	2	117	14,023	2	0	2	129	14,023	2	0	2	129
		R35	13,104	2	0	2	120	14,397	2	0	2	132	14,397	2	0	2	132
		R4	12,930	2	0	2	119	14,206	2	0	2	130	14,206	2	0	2	130
		R45	12,475	2	0	2	114	13,707	2	0	2	126	13,707	2	0	2	126
		R5	13,104	4	0	2	120	14,397	4	0	2	132	14,397	4	0	2	132
		R55	13,452	3	0	2	123	14,779	3	0	2	136	14,779	3	0	2	136
		AFR	12,791	2	0	1	117	14,053	2	0	2	129	14,053	2	0	2	129
		AFRR90	12,913	3	0	3	118	14,187	3	0	3	130	14,187	3	0	3	130
AFRL90	12,967	3	0	2	118	14,247	3	0	3	130	14,247	3	0	3	130		
P4	133W	R2	14,943	2	0	2	112	16,417	2	0	2	123	16,417	2	0	2	123
		R3	14,890	2	0	3	112	16,360	2	0	3	123	16,360	2	0	3	123
		R35	15,287	2	0	2	115	16,796	2	0	2	126	16,796	2	0	2	126
		R4	15,085	2	0	3	113	16,574	2	0	3	125	16,574	2	0	3	125
		R45	14,554	2	0	2	109	15,991	2	0	2	120	15,991	2	0	2	120
		R5	15,287	4	0	2	115	16,796	4	0	2	126	16,796	4	0	2	126
		R55	15,693	4	0	2	118	17,242	4	0	2	130	17,242	4	0	2	130
		AFR	14,923	2	0	2	112	16,395	2	0	2	123	16,395	2	0	2	123
		AFRR90	15,065	3	0	3	113	16,551	3	0	3	124	16,551	3	0	3	124
AFRL90	15,128	3	0	3	114	16,621	3	0	3	125	16,621	3	0	3	125		

## Dimensions & Weights

### Luminaire Weight by Mounting Type

Mounting Configuration	Total Luminaire Weight
SPA	22 lbs
RPA	24 lbs
MA	22 lbs
WBA	25 lbs
WBASC	28 lbs
IS	25 lbs
AASP	25 lbs
AARP	27 lbs
AAWB	28 lbs
AAWSC	31 lbs

#### RSX1 with Round Pole Adapter (RPA)

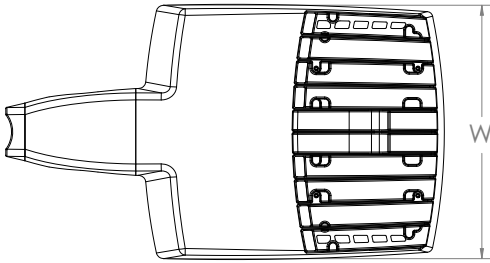

Length: 22.8" (57.9 cm)  
 Width: 13.3" (33.8 cm)  
 Height: 3.0" (7.6 cm) Main Body  
 7.2" (18.4 cm) Arm

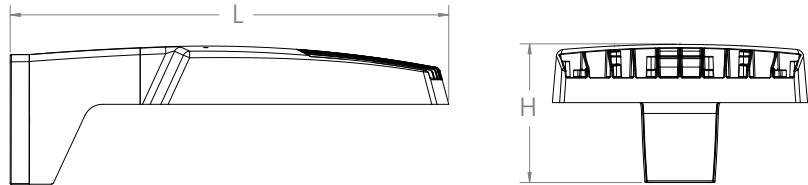

Note: RPA — Round Pole mount can also be used to mount on square poles by omitting the round pole adapter plate shown here.



#### RSX1 with Mast Arm Adapter (MA)

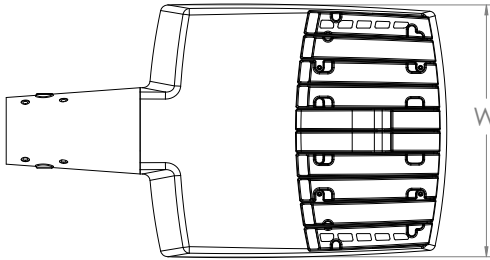

Length: 23.2" (59.1 cm)  
 Width: 13.3" (33.8 cm)  
 Height: 3.0" (7.6 cm) Main Body  
 3.5" (8.9 cm) Arm

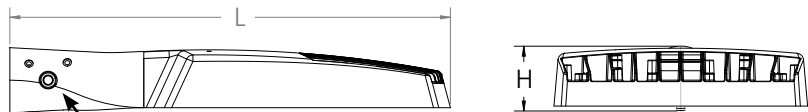

7/16" locking thru bolt/nut provided

#### RSX1 with Adjustable Slipfitter (IS)

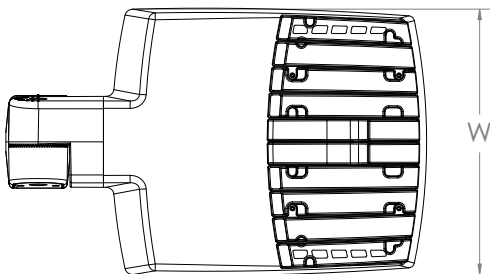

Length: 20.7" (52.7 cm)  
 Width: 13.3" (33.8 cm)  
 Height: 3.0" (7.6 cm) Main Body  
 7.6" (19.3 cm) Arm

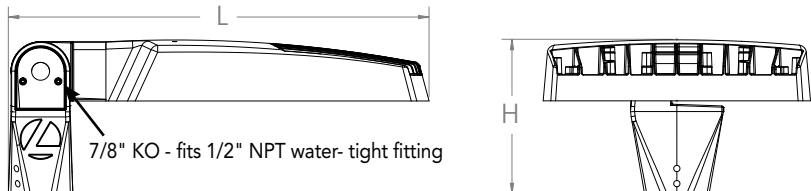

7/8" KO - fits 1/2" NPT water-tight fitting

## Dimensions

### RSX1 with Wall Bracket (WBA)

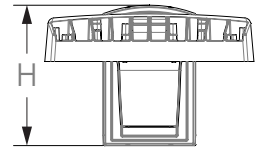
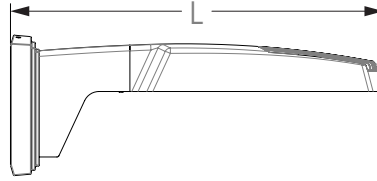
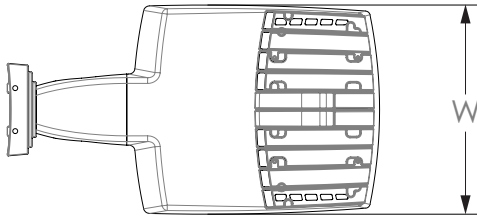

Length: 23.6" (59.9 cm)  
 Width: 13.3" (33.8 cm)  
 Height: 3.0" (7.6 cm) Main Body  
 8.9" (22.6 cm) Arm

#### Wall Bracket (WBA) Mounting Detail

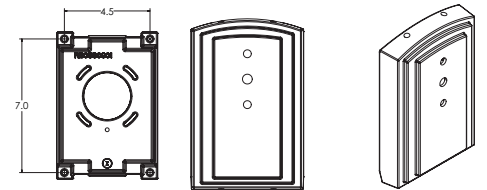

### RSX1 with Wall Bracket with Surface Conduit Box (WBASC)

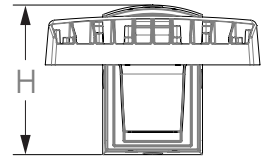
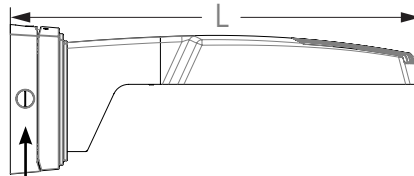
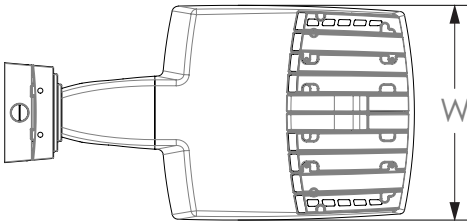

3/4" NPT taps with plugs - Qty (4) provided

Length: 25.3" (64.3 cm)  
 Width: 13.3" (33.8 cm)  
 Height: 3.0" (7.6 cm) Main Body  
 9.2" (23.4 cm) Arm

#### Surface Conduit Box (SCB) Mounting Detail

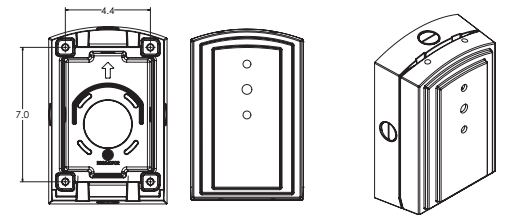

## Dimensions

### RSX1 with Adjustable Tilt Arm - Square or Round Pole (AASP or AARP)

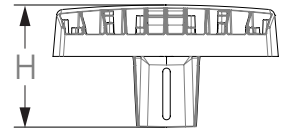
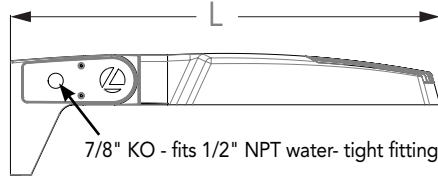
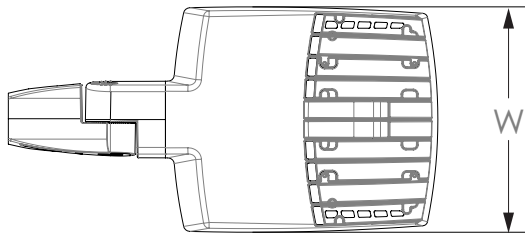

Length: 25.3" (65.3 cm) **AASP**  
 26.3" (66.8 cm) **AARP**  
 Width: 13.3" (33.8 cm)  
 Height: 3.0" (7.6 cm) Main Body  
 7.2" (18.2 cm) Arm

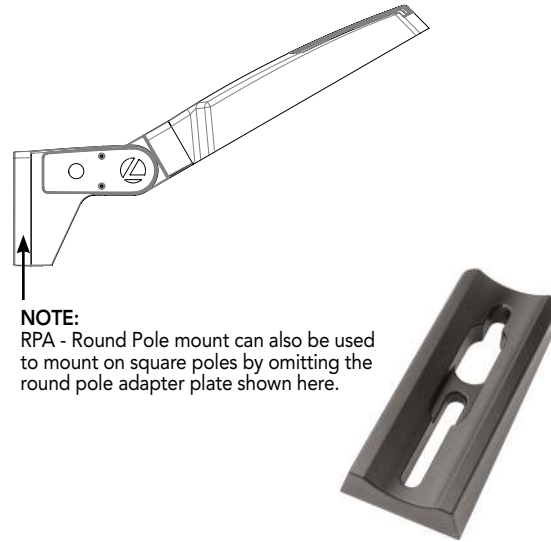

**NOTE:**  
 RPA - Round Pole mount can also be used to mount on square poles by omitting the round pole adapter plate shown here.

#### Notes

AASP: Requires 3.0" min. square pole for 1 at 90°. Requires 3.5" min. square pole for mounting 2, 3, 4 at 90°.

AARP: Requires 3.2" min. dia. round pole for 2, 3, 4 at 90°. Requires 3.0" min. dia. round pole for mounting 1 at 90°, 2 at 180°, 3 at 120°.

### RSX1 with Adjustable Tilt Arm with Wall Bracket (AAWB)

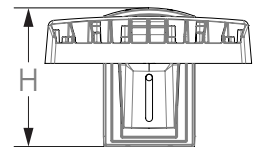
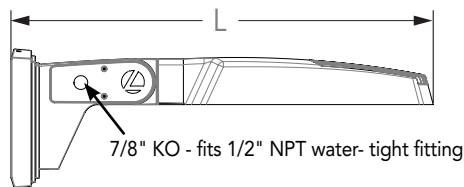
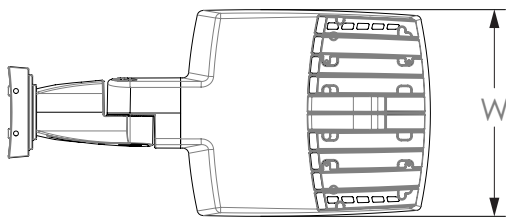

Length: 27.1" (68.8 cm)  
 Width: 13.3" (33.8 cm)  
 Height: 3.0" (7.6 cm) Main Body  
 8.9" (22.6 cm) Arm

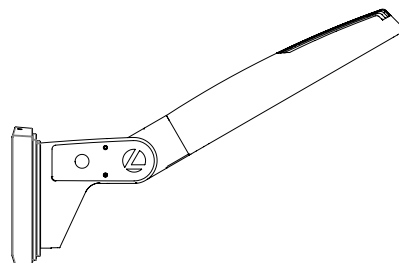

#### Wall Bracket (WBA) Mounting Detail

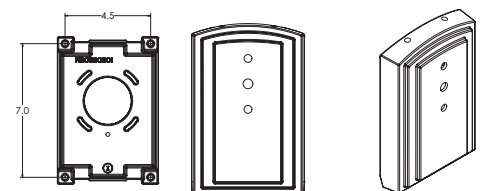

## Dimensions

### RSX1 with Adjustable Tilt Arm with Wall Bracket and Surface Conduit Box (AAWSC)

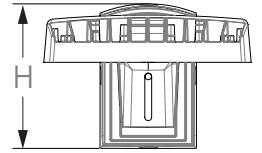
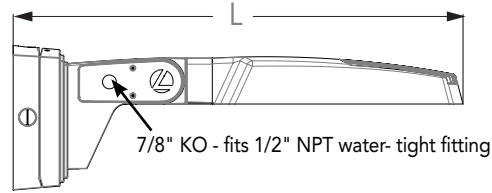
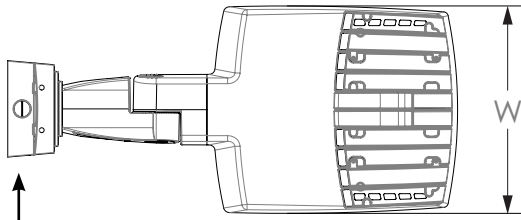

3/4" NPT taps with plugs - Qty (4) provided

Length: 28.8" (73.2 cm)  
 Width: 13.3" (33.8 cm)  
 Height: 3.0" (7.6 cm) Main Body  
 9.2" (23.4 cm) Arm

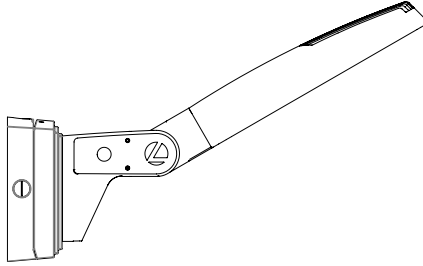

### Surface Conduit Box (SCB) Mounting Detail

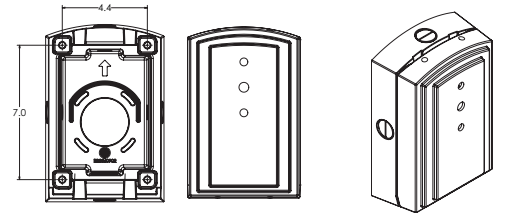

### Automotive Front Row - Rotated Optics (AFRR90/R90)

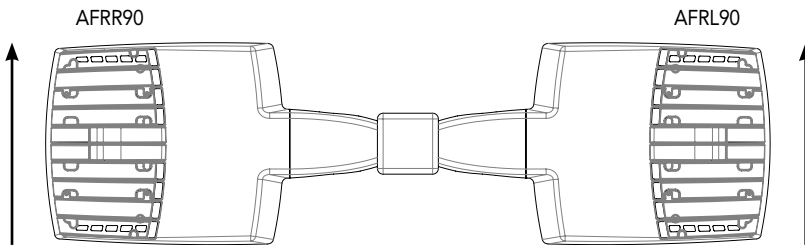

(Example: 2@180 - arrows indicate direction of light exiting the luminaire)

## nLight Sensor Coverage Pattern

### NLTAIR2 PIRHN

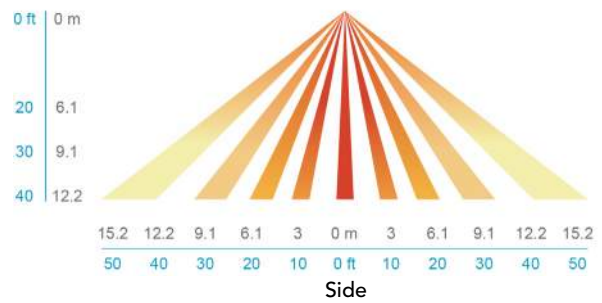
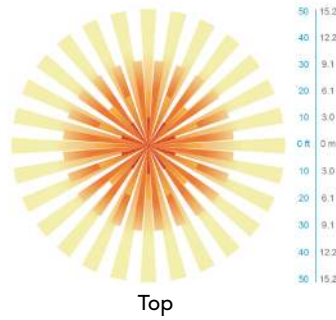
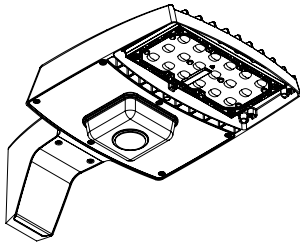

Motion Sensor Default Settings - Option PIRHN						
Option	Dimmed State (unoccupied)	High Level (when occupied)	Photocell Operation	Dwell Time (occupancy time delay)	Ramp-up Time (from unoccupied to occupied)	Ramp-down Time (from occupied to unoccupied)
NLTAIR2 PIRHN	Approx. 30% Output	100% Output	Enabled @ 1.5FC	7.5 minutes	3 seconds	5 minutes

\*Note: NLTAIR2 PIRHN default settings including photocell set-point, high/low dim rates, and occupancy sensor time delay are all configurable using the Clarity Pro App. Sensor coverage pattern shown with luminaire at 0°. Sensor coverage pattern is affected when luminaire is tilted.

## FEATURES & SPECIFICATIONS

### INTENDED USE

The RSX LED area luminaire is designed to provide a long-lasting, energy-efficient solution for the one-for-one replacement of existing metal halide or high pressure sodium lighting. The RSX1 delivers 7,000 to 17,000 lumens and is ideal for replacing 70W to 400W HID pole-mounted luminaires in parking lots and other area lighting applications.

### CONSTRUCTION

The RSX LED area luminaire features a rugged die-cast aluminum main body that uses heat-dissipating fins and flow-through venting to provide optimal thermal management that both enhances LED performance and extends component life. Integral "no drill" mounting arm allows the luminaire to be mounted on existing pole drillings, greatly reducing installation labor. The light engines and housing are sealed against moisture and environmental contaminants to IP66. The low-profile design results in a low EPA, allowing pole optimization. All mountings are rated for minimum 1.5 G vibration load per ANSI C136.31. 3G Mountings: Include SPA, RPA, MA, IS, AASP, and AARP rated for 3G vibration. 1.5G Mountings: Include WBA, WBASC, AAWB and AAWSC rated for 1.5G vibration.

### FINISH

Exterior parts are protected by a zinc-infused Super Durable TGIC thermoset powder coat finish that provides superior resistance to corrosion and weathering. A tightly controlled multi-stage process ensures superior adhesion as well as a minimum finish thickness of 3 mils. The result is a high-quality finish that is warrantied not to crack or peel.

### COASTAL CONSTRUCTION (CCE)

Optional corrosion-resistant construction is engineered with added corrosion protection in materials and/or pre-treatment of base material under super durable paint. Provides additional corrosion protection for applications near coastal areas. Finish is salt spray tested to over 5,000 hours per ASTM B117 with scribe rating of 10. Additional lead times apply.

### OPTICS

Precision acrylic refractive lenses are engineered for superior application efficiency, distributing the light to where it is needed most. Available in short and wide pattern distributions including Type 2, Type 3, Type 3S, Type 4, Type 4S, Type 5, Type 5S, AFR (Automotive Front Row), and AFR rotated AFR90 and ARFL90.

### ELECTRICAL

Light engine(s) configurations consist of high-efficacy LEDs mounted on metal-core circuit boards and aluminum heat sinks to maximize heat dissipation. Light engines are IP66 rated. LED lumen maintenance is >L92/100,000 hours. CCT's of 3000K, 4000K and 5000K (minimum 70 CRI) are available. Fixtures ship standard with 0-10v dimming driver. Class 1 electronic drivers ensure system power factor >90% and THD <20%. Easily serviceable 10kV surge protection device meets a minimum Category C Low operation (per ANSI/IEEE C62.41.2).

### STANDARD CONTROLS

The RSX LED area luminaire has a wide assortment of control options. Dusk to dawn controls include MVOLT and 347V button-type photocells and NEMA twist-lock photocell receptacles.

### nLIGHT AIR CONTROLS

The RSX LED area luminaire is also available with nLight® AIR for the ultimate in wireless control. This powerful controls platform provides out-of-the-box basic motion sensing with photocontrol functionality and is suitable for mounting heights up to 40 feet. No commissioning is required when using factory default settings that provide basic stand-alone motion occupancy dimming that is switched on and off with a built-in photocell. See chart above for motion sensor default out-of-box settings. For more advanced wireless functionality, such as group dimming, nLight AIR can be commissioned using a smartphone and the easy-to-use CLAIRITY app. nLight AIR equipped luminaires can be grouped, resulting in motion sensor and photocell group response without the need for additional equipment. Scheduled dimming with motion sensor over-ride can be achieved when used with the nLight Eclipse. Additional information about nLight Air can be found [here](#).

### INSTALLATION

Integral "no-drill" mounting arm allows for fast, easy mounting using existing pole drillings. Select the "SPA" option for square poles and the "RPA" option to mount to round poles. Note, the RPA mount can also be used for mounting to square poles by omitting the RPA adapter plate. Select the "MA" option to attach the luminaire to a 2 3/8" horizontal mast arm or the "IS" option for an adjustable slipfitter that mounts on a 2 3/8" OD tenon. The adjustable slipfitter has an integral junction box and offers easy installation. Can be tilted up to 90° above horizontal. Additional mountings are available including a wall bracket, adjustable tilt arm for direct-to-pole and wall and a surface conduit box for wall mount applications.

### LISTINGS

CSA Certified to meet U.S. and Canadian standards. Suitable for wet locations. Rated for -40°C minimum ambient. DesignLights Consortium® (DLC) Premium qualified product and DLC qualified product. Not all versions of this product may be DLC Premium qualified or DLC qualified. Please check the DLC Qualified Products List at [www.designlights.org/QPL](http://www.designlights.org/QPL) to confirm which versions are qualified.

International Dark-Sky Association (IDA) Fixture Seal of Approval (FSA) is available for all products on this page utilizing 3000K color temperature only. U.S. Patent No. D882, 146S

### GOVERNMENT PROCUREMENT

BAA – Buy America(n) Act: Product with the BAA option qualifies as a domestic end product under the Buy American Act as implemented in the FAR and DFARS. Product with the BAA option also qualifies as manufactured in the United States under DOT Buy America regulations. BABA – Build America Buy America: Product with the BAA option also qualifies as produced in the United States under the definitions of the Build America, Buy America Act. Please refer to [www.acuitybrands.com/buy-american](http://www.acuitybrands.com/buy-american) for additional information.

### WARRANTY

5-year limited warranty. This is the only warranty provided and no other statements in this specification sheet create any warranty of any kind. All other express and implied warranties are disclaimed. Complete warranty terms located at: [www.acuitybrands.com/support/warranty/terms-and-conditions](http://www.acuitybrands.com/support/warranty/terms-and-conditions)

**Note:** Actual performance may differ as a result of end-user environment and application. All values are design or typical values, measured under laboratory conditions at 25 °C. Specifications subject to change without notice.





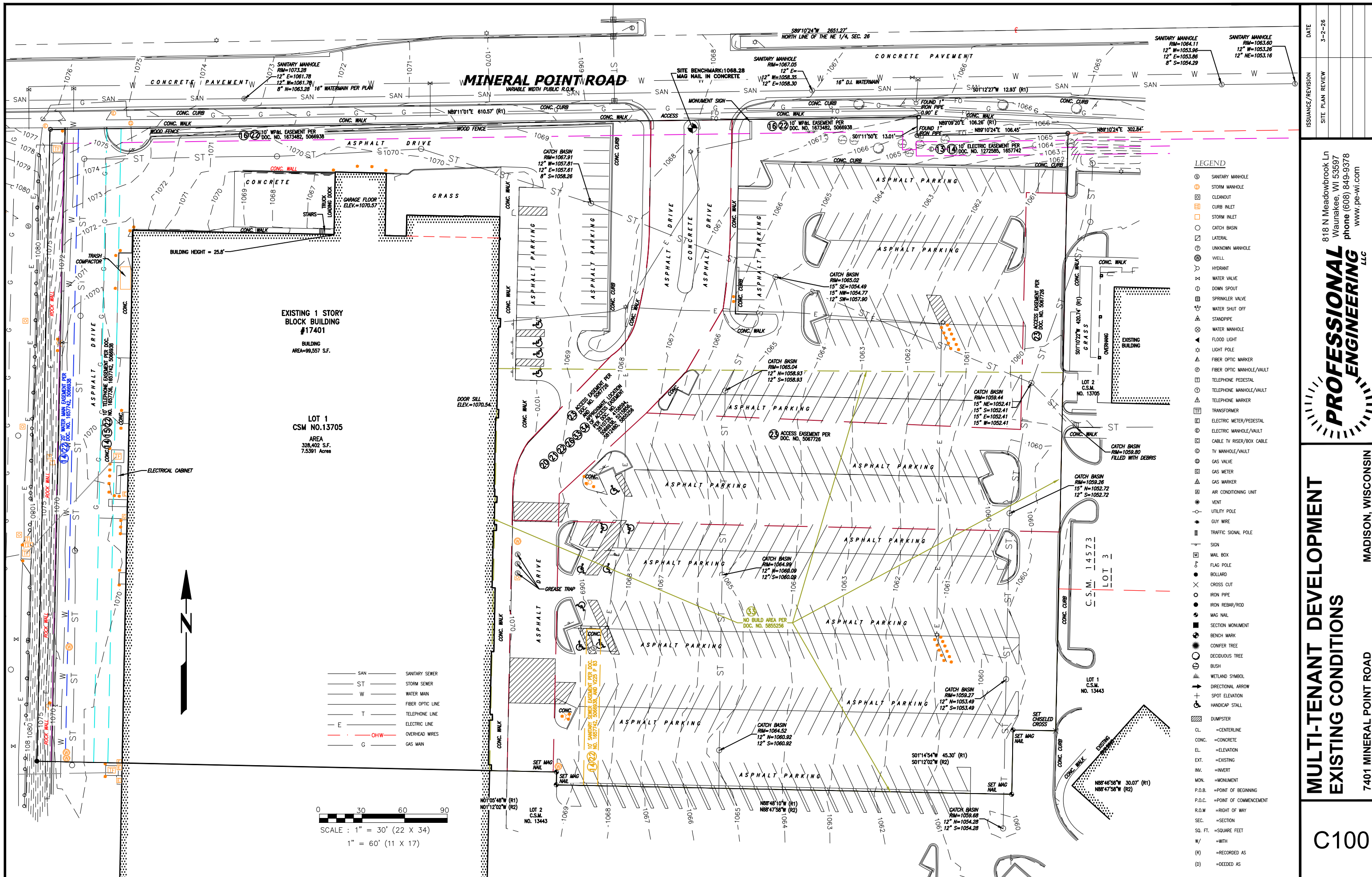

EXISTING 1 STORY  
BLOCK BUILDING  
#17401  
BUILDING  
AREA=99,557 SF.

LOT 1  
CSM NO.13705  
AREA  
328,402 SF.  
7.5391 Acres

- SAN ————— SANITARY SEWER
- ST ————— STORM SEWER
- W ————— WATER MAIN
- F ————— FIBER OPTIC LINE
- T ————— TELEPHONE LINE
- E ————— ELECTRIC LINE
- OHW ———— OVERHEAD WIRES
- G ————— GAS MAIN

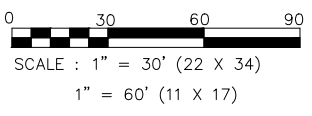

**LEGEND**

- SANITARY MANHOLE
- STORM MANHOLE
- CLEANOUT
- CURB INLET
- STORM INLET
- CATCH BASIN
- LATERAL
- UNKNOWN MANHOLE
- WELL
- HYDRANT
- WATER VALVE
- DOWN SPOUT
- SPRINKLER VALVE
- WATER SHUT OFF
- STANDPIPE
- WATER MANHOLE
- FLOOD LIGHT
- LIGHT POLE
- FIBER OPTIC MARKER
- FIBER OPTIC MANHOLE/VAULT
- TELEPHONE PEDESTAL
- TELEPHONE MANHOLE/VAULT
- TELEPHONE MARKER
- TRANSFORMER
- ELECTRIC METER/PEDESTAL
- ELECTRIC MANHOLE/VAULT
- CABLE TV RISER/BOX CABLE
- TV MANHOLE/VAULT
- GAS VALVE
- GAS METER
- GAS MARKER
- AIR CONDITIONING UNIT
- VENT
- UTILITY POLE
- GUY WIRE
- TRAFFIC SIGNAL POLE
- SIGN
- MAIL BOX
- FLAG POLE
- BOLLARD
- CROSS CUT
- IRON PIPE
- IRON REBAR/ROD
- MAG NAIL
- SECTION MONUMENT
- BENCH MARK
- CONIFER TREE
- DECIDUOUS TREE
- BUSH
- WETLAND SYMBOL
- DIRECTIONAL ARROW
- SPOT ELEVATION
- HANDICAP STALL
- DUMPSTER
- CL ———— CENTERLINE
- CONC. ——— CONCRETE
- EL. ——— ELEVATION
- EXT. ——— EXISTING
- INV. ——— INVERT
- MON. ——— MONUMENT
- P.O.B. ——— POINT OF BEGINNING
- P.O.C. ——— POINT OF COMMENCEMENT
- R.O.W. ——— RIGHT OF WAY
- SEC. ——— SECTION
- SQ. FT. ——— SQUARE FEET
- W/ ——— WITH
- (R) ——— RECORDED AS
- (D) ——— DECEDED AS

ISSUANCE/REVISION	DATE
SITE PLAN REVIEW	3-2-26

818 N Meadowbrook Ln  
Waukegan, WI 53597  
phone (608) 849-9378  
www.pe-wi.com

**PROFESSIONAL ENGINEERING** LLC

**MULTI-TENANT DEVELOPMENT  
EXISTING CONDITIONS**

MADISON, WISCONSIN

7401 MINERAL POINT ROAD

**C100**

**PLAN KEY**

- 1 CONSTRUCTION LIMITS
- 2 UTILITY PATCH PER CITY REQUIREMENTS (SEE UTILITY PLAN)
- 3 REMOVE ASPHALT
- 4 REMOVE CONCRETE, TYPICAL
- 5 REMOVE CURB AND GUTTER
- 6 REMOVE CURB
- 7 REMOVE TREES
- 8 REMOVE LIGHT POLE
- 9 CONCRETE TO REMAIN

**NOTES:**

- A. CONTRACTOR IS RESPONSIBLE FOR VERIFYING ALL UTILITIES PRIOR TO BEGINNING DEMOLITION OPERATIONS. NOTIFY DIGGERS HOTLINE 5 WORKING DAYS PRIOR TO START OF DEMOLITION/ CONSTRUCTION. CONTRACTOR TO PAY FOR PRIVATE LOCATES.
- B. THE CONTRACTOR WILL BE RESPONSIBLE FOR REMOVING TREES, STUMPS, ROOTS, AND OTHER ITEMS THAT ARE NOT NOTED TO REMAIN PER THE CONSTRUCTION DRAWINGS AND WHICH INTERFERE WITH NEW CONSTRUCTION.
- C. GENERAL CONTRACTOR TO DISPOSE OF ALL DEMOLITION / CONSTRUCTION MATERIALS OFF SITE IN A LEGAL MANNER EXCEPT FOR THOSE ITEMS NOTED TO BE SALVAGED.
- D. ALL MATERIALS, UTILITIES, AND SIDEWALK DAMAGED BY THE CONTRACTOR AS A RESULT OF THE DEMOLITION OPERATIONS SHALL BE REPAIRED OR REPLACED BY THE CONTRACTOR AT NO ADDITIONAL COST TO THE OWNER.
- E. CONTRACTOR SHALL PROTECT ALL EXISTING FACILITIES (INCLUDING BUT NOT LIMITED TO ELECTRICAL, WATER, SANITARY, SIDEWALK, ETC.) THAT ARE TO REMAIN.
- F. RESTORATION OF LAWN AREAS WITHIN THE PROJECT LIMITS IS CONSIDERED INCIDENTAL AND SHALL BE INCLUDED IN THE COST OF THE SITE IMPROVEMENTS.

**STREET TREE NOTES:**

- 1. STREET TREE ZONING FENCING IS REQUIRED FOR THIS PROJECT
- 2. FENCING SHALL BE ERECTED PRIOR TO DEMOLITION, GRADING OR CONSTRUCTION BEGINS.
- 3. THE FENCE SHALL INCLUDE THE ENTIRE WIDTH OF THE TERRACE, AND EXTEND AT LEAST 5 FEET ON BOTH SIDES OF THE OUTSIDE EDGE OF THE TREE TRUNK.
- 4. DO NOT REMOVE THE FENCING TO ALLOW FOR DELIVERIES OR EQUIPMENT ACCESS THROUGH THE TREE PROTECTION ZONE.
- 5. CONTRACTOR SHALL TAKE PRECAUTIONS DURING CONSTRUCTION TO NOT DISFIGURE, SCAR, OR IMPAIR THE HEALTH OF ANY STREET TREE.
- 6. CONTRACTOR SHALL OPERATE EQUIPMENT IN A MANNER AS TO NOT DAMAGE THE BRANCHES OF THE STREET TREE(S). THIS MAY REQUIRE USING SMALLER EQUIPMENT AND LOADING AND UNLOADING MATERIALS IN A DESIGNATED SPACE AWAY FROM TREES ON THE CONSTRUCTION SITE. ANY DAMAGE OR INJURY TO EXISTING STREET TREES (EITHER ABOVE OR BELOW GROUND) SHALL BE REPORTED IMMEDIATELY TO CITY FORESTRY AT (608) 266-4816. PENALTIES AND REMEDIATION SHALL BE REQUIRED.

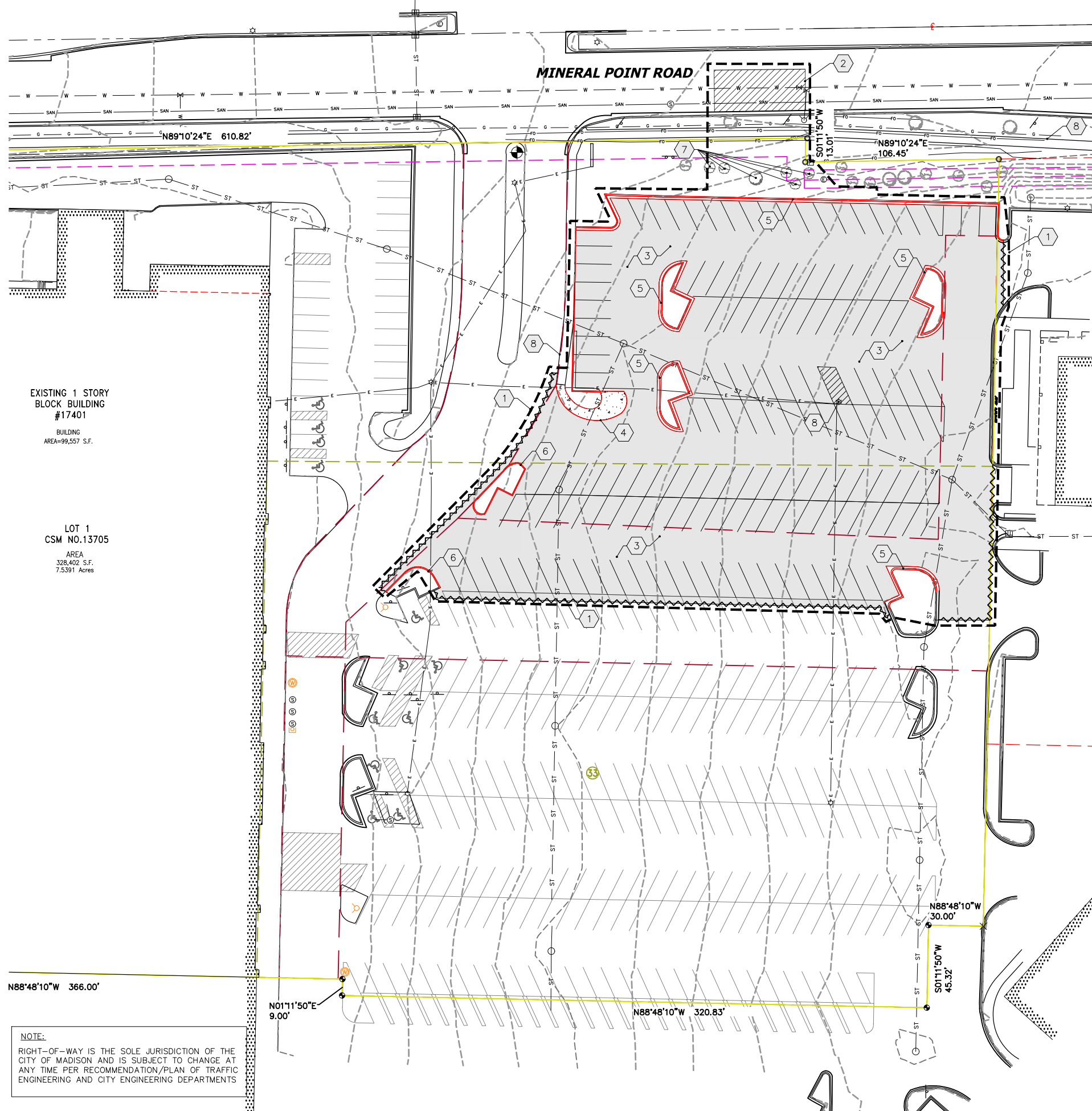

EXISTING 1 STORY  
BLOCK BUILDING  
#17401  
BUILDING  
AREA=99,557 S.F.

LOT 1  
CSM NO.13705  
AREA  
328,402 S.F.  
7.5391 Acres

N88°48'10"W 366.00'

N01°11'50"E 9.00'

N88°48'10"W 320.83'

N88°48'10"W 30.00'

S01°11'50"W 45.32'

N89°10'24"E 610.82'

S01°11'50"W 13.01'

N89°10'24"E 106.45'

**KEY**

- REMOVE EXISTING ASPHALT
- REMOVE EXISTING CONCRETE
- REMOVE CURB AND GUTTER
- SAWCUT ASPHALT



0 30 60  
SCALE : 1" = 60' (11 X 17)

**NOTE:**  
RIGHT-OF-WAY IS THE SOLE JURISDICTION OF THE CITY OF MADISON AND IS SUBJECT TO CHANGE AT ANY TIME PER RECOMMENDATION/PLAN OF TRAFFIC ENGINEERING AND CITY ENGINEERING DEPARTMENTS

ISSUANCE/REVISION	DATE
SITE PLAN REVIEW	3-2-26

818 N Meadowbrook Ln  
Waukegan, WI 53597  
phone (608) 849-9378  
www.pe-wi.com



**MULTI-TENANT DEVELOPMENT  
DEMOLITION PLAN**  
7401 MINERAL POINT ROAD  
MADISON, WISCONSIN

**C200**

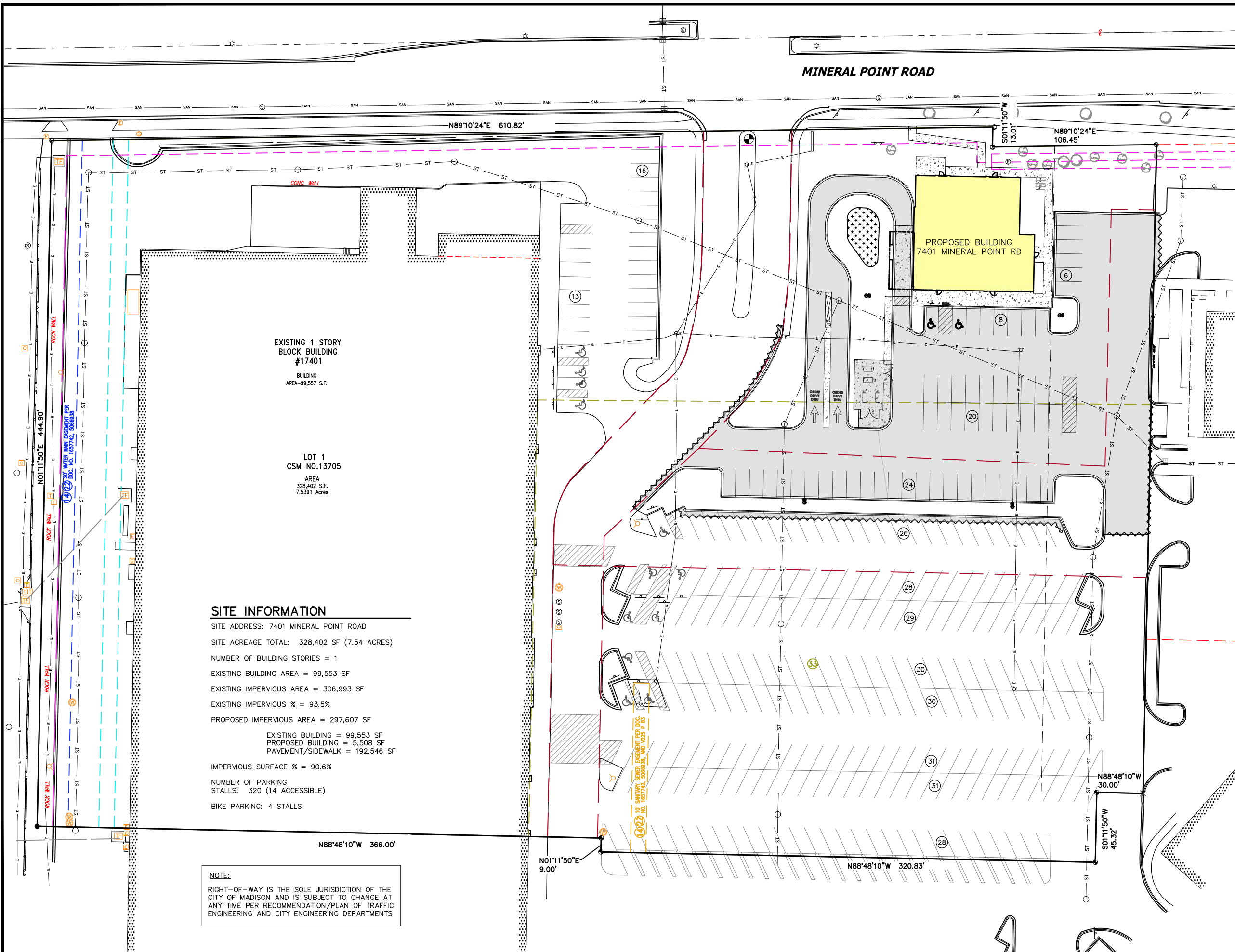

EXISTING 1 STORY  
BLOCK BUILDING  
#17401  
BUILDING  
AREA=99,557 S.F.



LOT 1  
CSM NO.13705  
AREA  
328,402 S.F.  
7.5391 Acres

**SITE INFORMATION**

SITE ADDRESS: 7401 MINERAL POINT ROAD  
 SITE ACREAGE TOTAL: 328,402 SF (7.54 ACRES)  
 NUMBER OF BUILDING STORIES = 1  
 EXISTING BUILDING AREA = 99,553 SF  
 EXISTING IMPERVIOUS AREA = 306,993 SF  
 EXISTING IMPERVIOUS % = 93.5%  
 PROPOSED IMPERVIOUS AREA = 297,607 SF  
 EXISTING BUILDING = 99,553 SF  
 PROPOSED BUILDING = 5,508 SF  
 PAVEMENT/SIDEWALK = 192,546 SF  
 IMPERVIOUS SURFACE % = 90.6%  
 NUMBER OF PARKING  
 STALLS: 320 (14 ACCESSIBLE)  
 BIKE PARKING: 4 STALLS

**NOTE:**  
 RIGHT-OF-WAY IS THE SOLE JURISDICTION OF THE  
 CITY OF MADISON AND IS SUBJECT TO CHANGE AT  
 ANY TIME PER RECOMMENDATION/PLAN OF TRAFFIC  
 ENGINEERING AND CITY ENGINEERING DEPARTMENTS

**KEY**

-  ASPHALT PAVEMENT
-  CONCRETE
-  CONCRETE PAVEMENT



0 30 60  
 SCALE : 1" = 60' (11 X 17)

ISSUANCE/REVISION	DATE
SITE PLAN REVIEW	3-2-26

818 N Meadowbrook Ln  
 Waunakee, WI 53597  
 phone (608) 849-9378  
 www.pe-wi.com

**PROFESSIONAL ENGINEERING LLC**

**MULTI-TENANT DEVELOPMENT  
 OVERALL SITE PLAN**

MADISON, WISCONSIN  
 7401 MINERAL POINT ROAD

**C200**

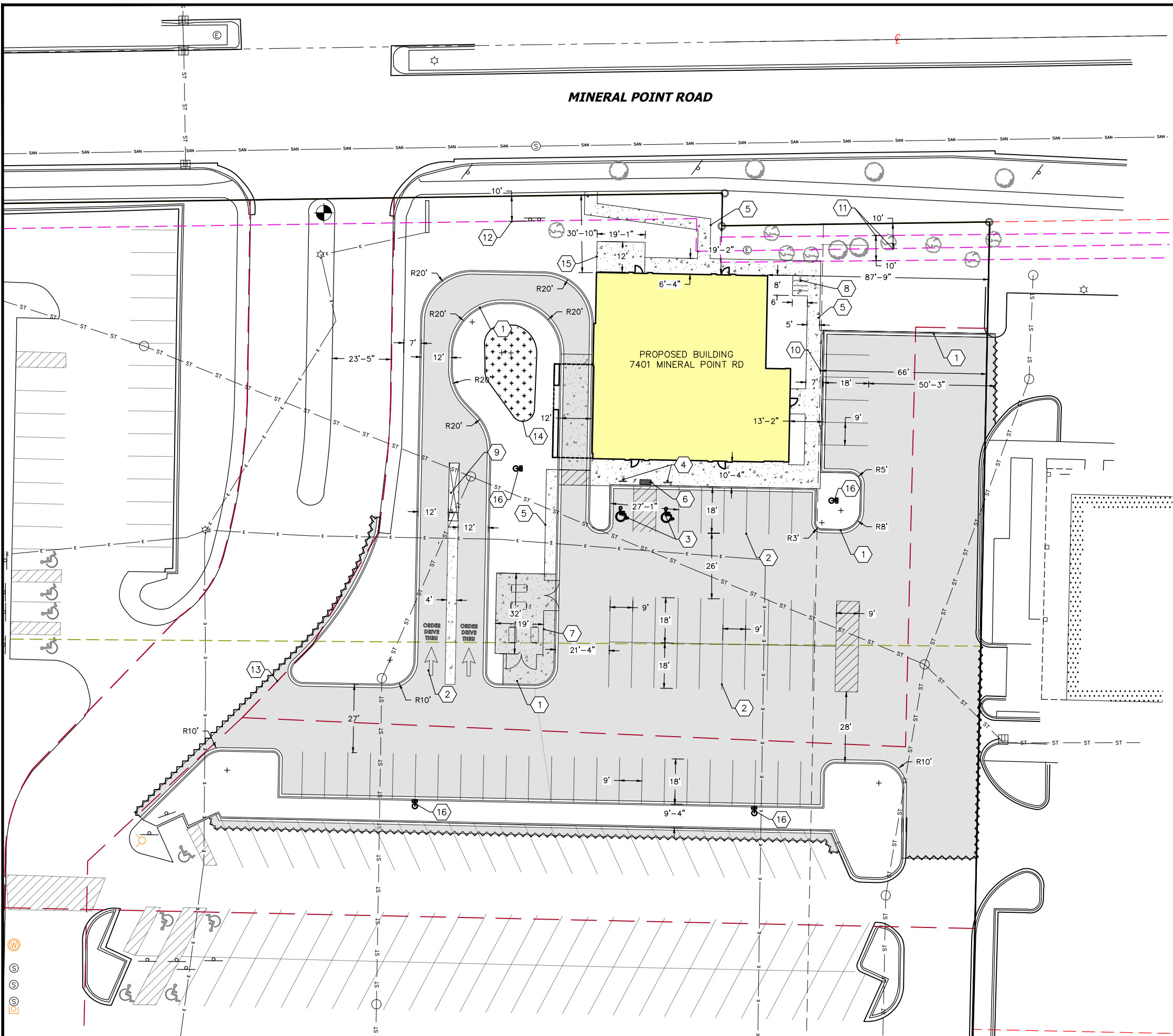

**PLAN KEY**

- 1 18" CURB AND GUTTER
- 2 4" PAVEMENT STRIPING WITH TWO COATS OF TRAFFIC GRADE LATEX PAINT, TYP
- 3 ACCESSIBLE STALL, TYP.
- 4 VAN ACCESSIBLE PARKING SIGN, TYP.
- 5 CONCRETE SIDEWALK, TYP.
- 6 CURB RAMP, W/DETECTABLE WARNING FIELD, TYP
- 7 SCREENED DUMPSTER, (SEE ARCHITECTURAL PLANS)
- 8 BIKE RACKS TO BE DERO PART# BH-FE-EPX BIKE RACKS SURFACE MOUNT POWDER COAT FINISH
- 9 DRIVE-THRU MENU BOARD
- 10 66' RIGHT OF WAY FOR FUTURE PUBLIC STREET
- 11 EXISTING 10' ELECTRIC EASEMENT PER DOC. NO. 1272585, 1657742
- 12 EXISTING 10' WP&L EASEMENT PER DOC. NO. 1673482, 5066938
- 13 EXISTING ACCESS EASEMENT PER DOC. NO. 5067726 AND APPROXIMATE LOCATION OF ACCESS EASEMENT PER DOC. NO. 2610739, 4158594, 5066938, 5215856, 5812480, 5855256
- 14 BIORETENTION STORMWATER MANAGEMENT DEVICE
- 15 350SF OUTDOOR PATIO
- 16 LIGHT POLE

**NOTE:**  
 RIGHT-OF-WAY IS THE SOLE JURISDICTION OF THE CITY OF MADISON AND IS SUBJECT TO CHANGE AT ANY TIME PER RECOMMENDATION/PLAN OF TRAFFIC ENGINEERING AND CITY ENGINEERING DEPARTMENTS

**KEY**

- ASPHALT PAVEMENT
- CONCRETE
- CONCRETE PAVEMENT
- SAWCUT ASPHALT

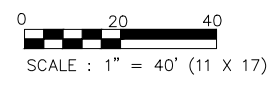

ISSUANCE/REVISION	DATE
SITE PLAN REVIEW	3-2-26

818 N Meadowbrook Ln  
 Waunakee, WI 53597  
 phone (608) 849-9378  
 www.pe-wi.com

**PROFESSIONAL ENGINEERING LLC**

**MULTI-TENANT DEVELOPMENT SITE PLAN**

MADISON, WISCONSIN

7401 MINERAL POINT ROAD

**C201**

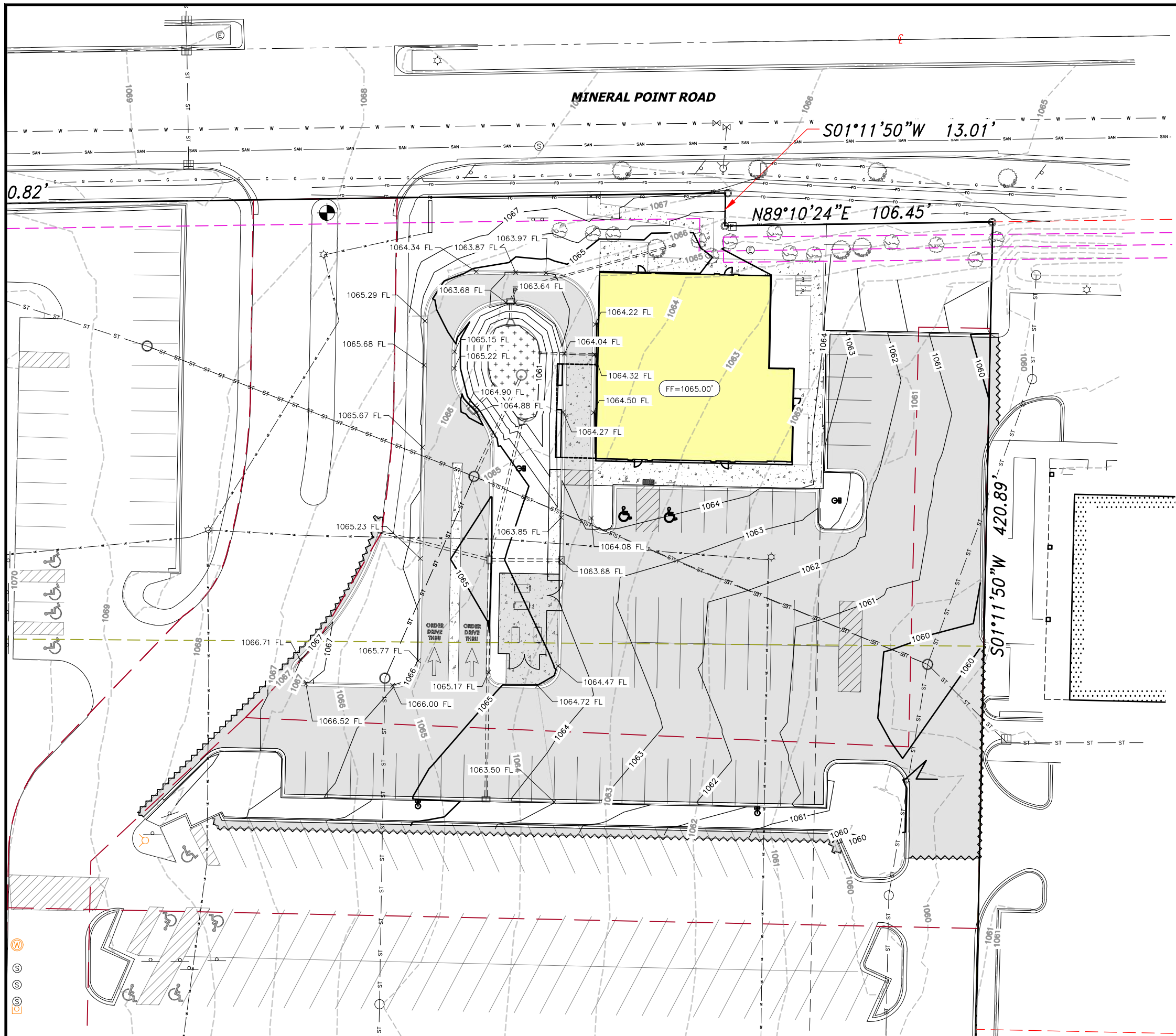

**GRADING NOTES**

1. CONTRACTOR SHALL CALL DIGGERS HOTLINE PRIOR TO ANY CONSTRUCTION.
2. ALL MATCHING PAVEMENT AND STORM SEWER ELEVATIONS SHALL BE VERIFIED IN THE FIELD TO ALLOW FOR PROPER DRAINAGE.
3. CONTOUR AND SPOT ELEVATIONS SHOWN ARE FINISH GRADE ELEVATIONS.
4. ALL LAWN AND PLANTING AREAS WHICH HAVE BEEN COMPACTED DUE TO CONSTRUCTION SHALL BE LOOSENEED PRIOR TO ADDITION OF TOPSOIL.
5. SIDEWALKS SHALL HAVE A MAXIMUM CROSS SLOPE OF 2% (1:50).

**GRADING LEGEND**

- EXISTING CONTOUR
- PROPOSED CONTOUR
- × 1000.00 P PAVEMENT ELEVATION
- × 1000.00 FL FLOW LINE ELEVATION
- × 1000.00 TW TOP OF RETAINING WALL ELEVATION
- × 1000.00 BW BOTTOM OF RETAINING WALL ELEVATION

**NOTE:**  
 RIGHT-OF-WAY IS THE SOLE JURISDICTION OF THE CITY OF MADISON AND IS SUBJECT TO CHANGE AT ANY TIME PER RECOMMENDATION/PLAN OF TRAFFIC ENGINEERING AND CITY ENGINEERING DEPARTMENTS

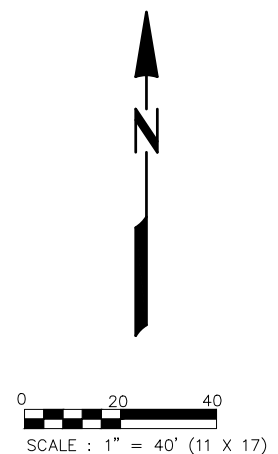

ISSUANCE/REVISION	DATE
SITE PLAN REVIEW	3-2-26

818 N Meadowbrook Ln  
 Waunakee, WI 53597  
 phone (608) 849-9378  
 www.pe-wi.com

**PROFESSIONAL ENGINEERING LLC**

**MULTI-TENANT DEVELOPMENT GRADING PLAN**

MADISON, WISCONSIN

7401 MINERAL POINT ROAD

**C300**

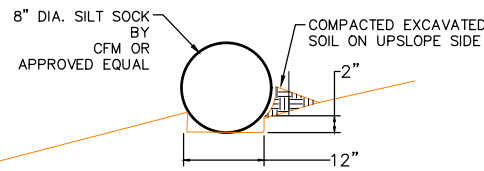

2 SILT SOCK  
C302 NTS

**KEY**

—○— SILT SOCK

WISCONSIN DOT CLASS 1, URBAN, TYPE B, EROSION MAT. CONTRACTOR TO ALLEVIATE SOIL COMPACTION BY DEEP TILLING GRASS AREAS

AVERAGE DIMENSION FOR LIGHT RIPRAP (INCHES)	FRACTION OF GROSS IN-PLACE RIPRAP OCCUPIED VOLUME BY STONES
> 16	0%
11-13	10%-14%
9-11	15%-21%
4-9	20%-28%
< 4	5%-7%
< 1	2% OR LESS

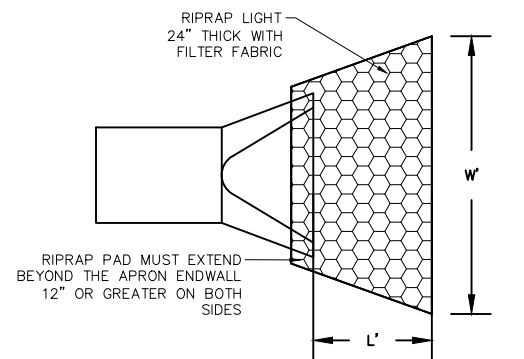
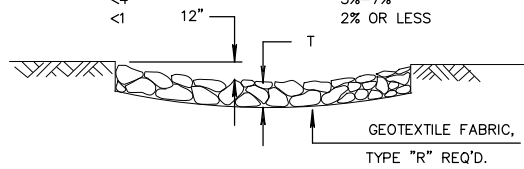

**DIMENSION TABLE**

APRON ENDWALL	LENGTH - L (FT)	WIDTH - W (FT)	THICKNESS (T) (INCHES)
1.1 AE	6'	6'	24

2 RIP RAP & GEOTEXTILE FABRIC AT APRON ENDWALLS  
C200 NTS

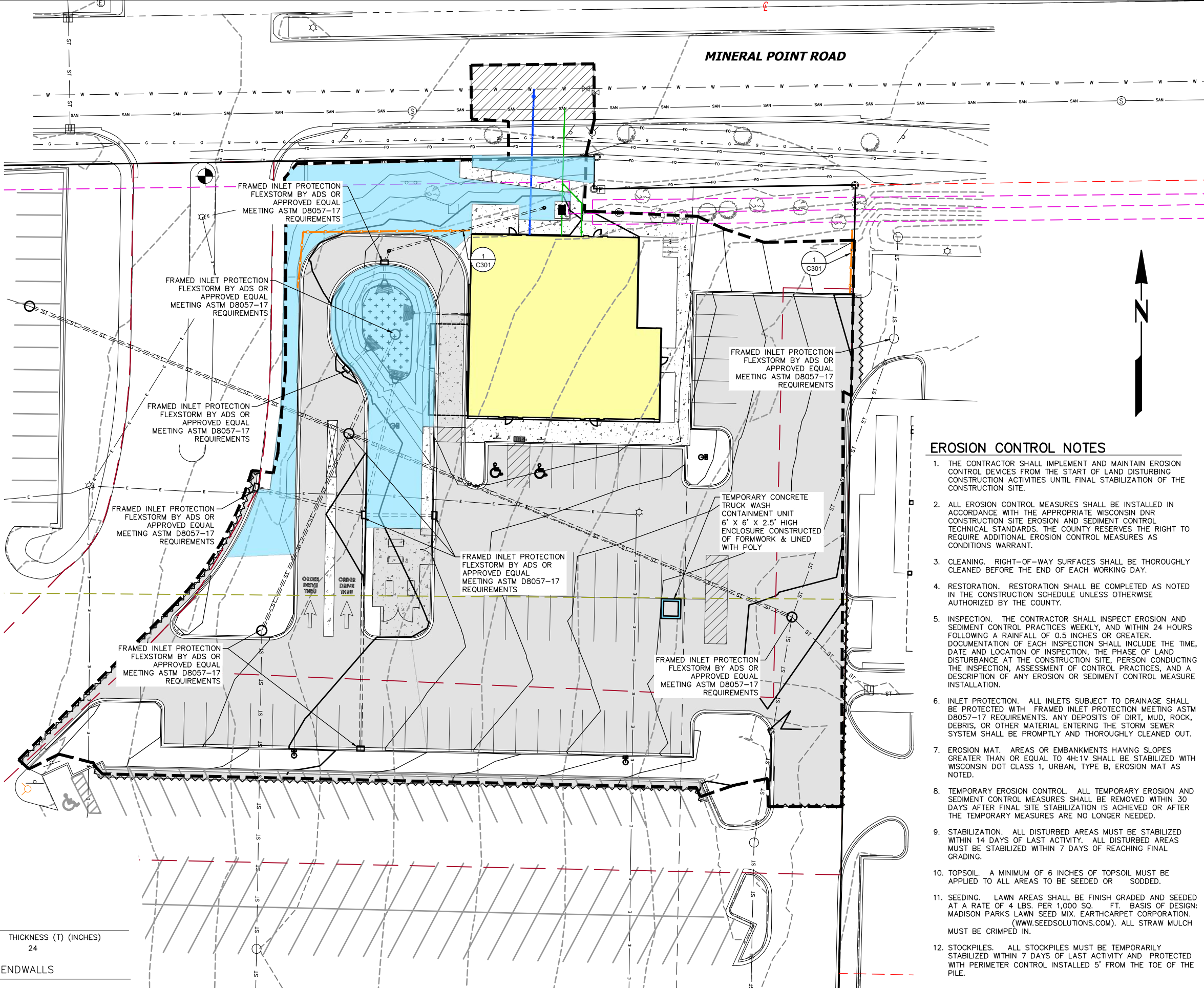

**EROSION CONTROL NOTES**

1. THE CONTRACTOR SHALL IMPLEMENT AND MAINTAIN EROSION CONTROL DEVICES FROM THE START OF LAND DISTURBING CONSTRUCTION ACTIVITIES UNTIL FINAL STABILIZATION OF THE CONSTRUCTION SITE.
2. ALL EROSION CONTROL MEASURES SHALL BE INSTALLED IN ACCORDANCE WITH THE APPROPRIATE WISCONSIN DNR CONSTRUCTION SITE EROSION AND SEDIMENT CONTROL TECHNICAL STANDARDS. THE COUNTY RESERVES THE RIGHT TO REQUIRE ADDITIONAL EROSION CONTROL MEASURES AS CONDITIONS WARRANT.
3. CLEANING. RIGHT-OF-WAY SURFACES SHALL BE THOROUGHLY CLEANED BEFORE THE END OF EACH WORKING DAY.
4. RESTORATION. RESTORATION SHALL BE COMPLETED AS NOTED IN THE CONSTRUCTION SCHEDULE UNLESS OTHERWISE AUTHORIZED BY THE COUNTY.
5. INSPECTION. THE CONTRACTOR SHALL INSPECT EROSION AND SEDIMENT CONTROL PRACTICES WEEKLY, AND WITHIN 24 HOURS FOLLOWING A RAINFALL OF 0.5 INCHES OR GREATER. DOCUMENTATION OF EACH INSPECTION SHALL INCLUDE THE TIME, DATE AND LOCATION OF INSPECTION, THE PHASE OF LAND DISTURBANCE AT THE CONSTRUCTION SITE, PERSON CONDUCTING THE INSPECTION, ASSESSMENT OF CONTROL PRACTICES, AND A DESCRIPTION OF ANY EROSION OR SEDIMENT CONTROL MEASURE INSTALLATION.
6. INLET PROTECTION. ALL INLETS SUBJECT TO DRAINAGE SHALL BE PROTECTED WITH FRAMED INLET PROTECTION MEETING ASTM D8057-17 REQUIREMENTS. ANY DEPOSITS OF DIRT, MUD, ROCK, DEBRIS, OR OTHER MATERIAL ENTERING THE STORM SEWER SYSTEM SHALL BE PROMPTLY AND THOROUGHLY CLEANED OUT.
7. EROSION MAT. AREAS OR EMBANKMENTS HAVING SLOPES GREATER THAN OR EQUAL TO 4H:1V SHALL BE STABILIZED WITH WISCONSIN DOT CLASS 1, URBAN, TYPE B, EROSION MAT AS NOTED.
8. TEMPORARY EROSION CONTROL. ALL TEMPORARY EROSION AND SEDIMENT CONTROL MEASURES SHALL BE REMOVED WITHIN 30 DAYS AFTER FINAL SITE STABILIZATION IS ACHIEVED OR AFTER THE TEMPORARY MEASURES ARE NO LONGER NEEDED.
9. STABILIZATION. ALL DISTURBED AREAS MUST BE STABILIZED WITHIN 14 DAYS OF LAST ACTIVITY. ALL DISTURBED AREAS MUST BE STABILIZED WITHIN 7 DAYS OF REACHING FINAL GRADING.
10. TOPSOIL. A MINIMUM OF 6 INCHES OF TOPSOIL MUST BE APPLIED TO ALL AREAS TO BE SEEDED OR SODDED.
11. SEEDING. LAWN AREAS SHALL BE FINISH GRADED AND SEEDED AT A RATE OF 4 LBS. PER 1,000 SQ. FT. BASIS OF DESIGN: MADISON PARKS LAWN SEED MIX. EARTHCARPET CORPORATION. (WWW.SEEDSOLUTIONS.COM). ALL STRAW MULCH MUST BE CRIMPED IN.
12. STOCKPILES. ALL STOCKPILES MUST BE TEMPORARILY STABILIZED WITHIN 7 DAYS OF LAST ACTIVITY AND PROTECTED WITH PERIMETER CONTROL INSTALLED 5' FROM THE TOE OF THE PILE.

ISSUANCE/REVISION	DATE
SITE PLAN REVIEW	3-2-26

818 N Meadowbrook Ln  
Wauwatosa, WI 53597  
phone (608) 849-9378  
www.pe-wi.com

**PROFESSIONAL ENGINEERING** LC

**MULTI-TENANT DEVELOPMENT EROSION CONTROL PLAN**

MADISON, WISCONSIN

7401 MINERAL POINT ROAD

**C400**



STRUCTURE TABLE					
STRUCTURE NAME	SIZE	RIM*	PIPES IN	PIPES OUT	CASTING
1.1 CB EXISTING	EXISTING CATCH BASIN	1059.51	P1.1 EXISTING, 15" INV IN =1052.41		-
1.2 CB EXISTING	EXISTING CATCH BASIN	1065.24	P1.2 EXISTING, 15" INV IN =1054.77 P2.1 EXISTING, 15" INV IN =1057.90 P6.1, 12" INV IN =1056.59	P1.1 EXISTING, 15" INV OUT =1054.49	-
1.3 CB EXISTING	EXISTING CATCH BASIN	1068.32		P1.2 EXISTING, 15" INV OUT =1057.61	-
2.1 CB EXISTING	EXISTING CATCH BASIN	1066.53		P2.1 EXISTING, 15" INV OUT =1058.93	ADJUST CASTING TO MATCH NEW GRADE
3.1 AE	APRON ENDWALL	1062.25	P3.1, 12" INV IN =1061.00		-
3.2 INLET	2X3-FT	1063.67	P3.2, 8" INV IN =1060.77	P3.1, 12" INV OUT =1061.07	NEENAH R-3067
3.3 BEND	BEND	1063.75	P3.3, 8" INV IN =1060.82	P3.2, 8" INV OUT =1060.82	-
3.4 YARD INLET	15" BASIN	1064.25		P3.3, 8" INV OUT =1061.48	15" D.J. GRATE
4.1 AE	APRON ENDWALL	1062.25	P4.1, 12" INV IN =1061.00		-
4.2 INLET	2X3-FT	1064.87		P4.1, 12" INV OUT =1061.11	NEENAH R-3067
5.1 AE	APRON ENDWALL	1062.53		P5.1, 12" INV OUT =1061.28	-
5.2 INLET	2X3-FT	1063.67		P5.3, 12" INV OUT =1061.43	NEENAH R-3067
5.3 INLET	2X3-FT	1064.30		P5.2, 12" INV OUT =1061.76	NEENAH R-3067
5.4 INLET	2X3-FT	1064.69	P5.3, 12" INV IN =1061.28 P5.2, 12" INV IN =1061.28 P8.1, 12" INV IN =1061.50 P5.1, 12" INV IN =1061.00		NEENAH R-3067
6.1 POND	4-FT DIA.	1061.50		P6.1, 12" INV OUT =1057.04	HAALA #CG48TM
7.1 PIPE END	CUT PIPE TO CONFORM TO SLOPE	1061.75	P7.1, 8" INV IN =1061.04		-
7.2 ROOF	CONNECT TO ROOF DRAIN	1064.79		P7.1, 8" INV OUT =1061.26	-
8.1 INLET	2X3-FT	1066.08		P8.1, 12" INV OUT =1061.94	NEENAH R-3067

PIPE TABLE						
NAME	SIZE	LENGTH	SLOPE	MATERIAL	START INVERT ELEVATION	END INVERT ELEVATION
P1.1 EXISTING	15"	196'	1.07%	ADS N12	1054.49'	1052.41'
P1.2 EXISTING	15"	140'	2.03%	ADS N12	1057.61'	1054.77'
P2.1 EXISTING	15"	88'	1.18%	ADS N12	1058.93'	1057.90'
P3.1	12"	8'	0.97%	ADS N12	1061.07'	1061.00'
P3.2	8"	6'	1.00%	ADS N12	1060.82'	1060.77'
P3.3	8"	66'	1.01%	ADS N12	1061.48'	1060.82'
P4.1	12"	11'	1.00%	ADS N12	1061.11'	1061.00'
P5.1	12"	56'	0.50%	ADS N12	1061.28'	1061.00'
P5.2	12"	96'	0.50%	ADS N12	1061.76'	1061.28'
P5.3	12"	29'	0.52%	ADS N12	1061.43'	1061.28'
P6.1	12"	45'	1.00%	ADS N12	1057.04'	1056.59'
P7.1	8"	23'	1.00%	ADS N12	1061.26'	1061.04'
P8.1	12"	46'	0.98%	ADS N12	1061.94'	1061.50'

ISSUANCE/REVISION	DATE
SITE PLAN REVIEW	3-2-26

818 N Meadowbrook Ln  
Waukegan, WI 53597  
phone (608) 849-9378  
www.pe-wi.com



**PROFESSIONAL ENGINEERING LLC**

**MULTI-TENANT DEVELOPMENT  
STORM SEWER SCHEDULE**

MADISON, WISCONSIN

7401 MINERAL POINT ROAD

C401

D  
C  
B  
A

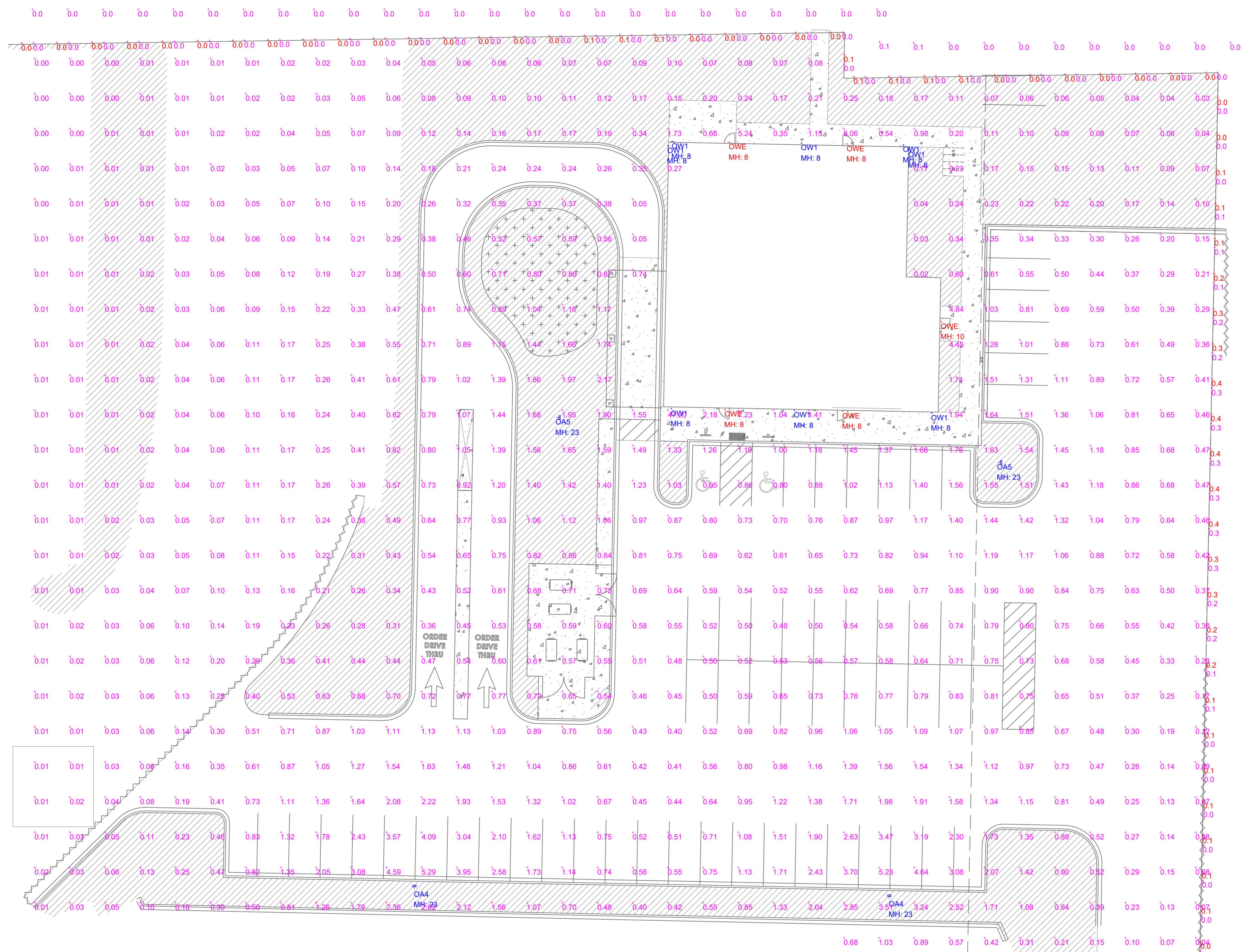

Label	Qty	Arrangement	LLF	Tag	Description	Lum. Watts	Total Watts	Lum. Lumens
OA4	2	Single	0.950	LITHONIA	RSX1 LED P3 xxK R4 + 20FT POLE + 3FT BASE	109.44	218.88	14206
OA5	2	Single	0.950	LITHONIA	RSX1 LED P3 xxK R5 + 20FT POLE + 3FT BASE	109.44	218.88	14394
OW1	8	Single	0.950	LUMINIS	SY300 L1LSNR VNR xxK MVOLT xxx	10.16	81.28	539
OWE	5	Single	0.950	LUMINIS	SY300 L1L10 WD xxK MVOLT xxx	12.5	62.5	846

Label	CalcType	Units	Avg	Max	Min	Avg/Min	Max/Min
10FT from PL	Illuminance	Fc	0.04	0.2	0.0	N.A.	N.A.
4FT above PL	Illuminance	Fc	0.05	0.3	0.0	N.A.	N.A.
PRESUMED PROPERTY LINE	Illuminance	Fc	0.09	0.4	0.0	N.A.	N.A.
PARKING LOT	Illuminance	Fc	1.28	5.29	0.34	3.76	15.56

### RSX1 LED Area Luminaire

**Specifications**

- EPA (ft@0°): 0.57 ft² (0.05 m²)
- Length: 21.8" (55.4 cm) (SPA mount)
- Width: 13.3" (33.8 cm)
- Height: 3.0" (7.6 cm) Main Body, 7.2" (18.4 cm) Arm
- Weight (SPA mount): 22.0 lbs (10.0 kg)

**Introduction**

The new RSX1 LED Area family delivers maximum value by providing significant energy savings, long life and outstanding photometric performance at an affordable price. The RSX1 delivers 7,000 to 17,000 lumens allowing it to replace 70W to 400W HID luminaires.

The RSX1 features an integral universal mounting mechanism that allows the luminaire to be mounted on most existing drill hole patterns. This "no-drill" solution provides significant labor savings. An easy-access door on the bottom of mounting arm allows for wiring without opening the electrical compartment. A mast arm adaptor, adjustable integral splittier and other mounting configurations are available.

**Ordering Information**

EXAMPLE: RSX1 LED P4 40K R3 MVOLT SPA DDBXD

Series	Performance Package	Color Temperature	Distribution	Voltage	Mounting
RSX1 LED	P1	30K	R2	MVOLT (120V-277V)	SPA
	P2	40K	R3	MVOLT (120V-480V)	RFA
	P3	50K	R5	MVOLT (277V-480V)†	IS
	P4	50K	R4	(use specific voltage for options as noted)	MA

Options	Shipped Installed	Finish
HS: House-side shield*	Shipped Installed: Standalone and Networked Sensors/Controls (factory default settings, see table page 9)	DDBXD: Dark Bronze
PE: Photocell, bottom eye**	ULM2R PRRM: Light Rail Generation 2, with Networked, 0-10V dimmer (ambience sensor)†††	DBLXD: Black
PER: Open wire hand lock (replace easily (no controls)†††)	BAA: Bay Area's Air and/or Build America Buy America Qualified	DRAXD: Natural Aluminum
SF: Single face (120, 277, 347)	CEE: Coastal Construction†	DRWDX: White
DF: Double face (208, 240, 480)	*Note: NLTAR2 PRRM with Light Air can be used as a standalone or networked solution. Sensor coverage pattern is affected when luminaire is tilted.	DOBXD: Insulated Dark Bronze
SFD20KV: 20KV Surge pack (100V standard)	Shipped Separately (requires some field assembly)	DBLBD: Insulated Black
FAO: Field adjustable output†	EGS: External glare shield	DBLXD: Insulated Natural Aluminum
DMG: 0-10V dimmer control (not included) for external control (cannot be separated)†	EGV: External glare shield (30° around light aperture)†	DWDXD: Insulated White
	BS: Bird spikes*	

### LUMINIS SY300 SYRIOS WALL

SY300 ORDERING CODE

*SERIES	*LIGHT OUTPUT	*DISTRIBUTION	*CCT*	*VOLTAGE	CONDUIT COVER
SY300	Static White	FLD Flood optic 20°	27K 2700K	120 120V	[SWK] Decorative cover for 3/4" conduit junction box*
	L1L10 924 lm / 13w		30K 3000K	277 277V	
	True Amber	WD Wide optic 42°	35K 3500K	MVOLT 120V-277V	
	L1LK2A 124 lm / 7w†	40K 4000K	48K 4800K		
		VNR Very narrow optic 9°			

MOUNTING ACCESSORY	MOUNTING DIRECTION	LENS/DIFFUSER	FUSE	EMERGENCY
MT4 Trim plate for 4" octagonal in-box	UP Uplight position	LSL Linear spread lens SL Solite lens*	FS Fuse	REM7 Remote emergency battery, 90 min, 7W†

SHIELDING ACCESSORIES	LOUVERS	*FINISH	WOOD FINISH*	ENVIRONMENT	HEIGHT MATCHING
SNT Snoot*	HL Hexcell louver	BKT Jet black BZT Bronze CHT Champagne CMT Copper DGT Gun metal GRY Titanium gray MST Matte silver SGT Steel gray WHT Snow white	ADG American grade Douglas Birch BRC Chestnut CHN Chestnut CRY Cherry KNP Knotty pine MPL Maple OFL Oak RSW Rosewood TEK Teak WLN Walnut	MG Marine grade paint†† NT Necessarium suitable†	UH Uniform height matching 5/3200
		CMC Custom matched color†			
		RAL RAL color††			

- NOTES**
- Denotes a required field.
  - Available only with AMR option.
  - Available only with VNR distribution option. Not available with 27K, 35K or AMB.
  - Field angle 21°.
  - For ICA certification compliance, luminaire must be ordered with 300K or warmer.
  - Not available with HTA. Painted to match fixture color.
  - Lumen conversion factor (LCF) 0.9.
  - Remote requires 50W 12" square enclosure with access cover. The remote enclosure must be interior. Cable between fixture and remote box is provided by others.
  - To prevent reflections, interior painted black when a light color finish is selected (ex. WHT, MST, GRY and CMT). 1.5" (38mm) deep.
  - Contact factory to coordinate custom matching color.
  - Specify RAL number.
  - Finish wood finish not applied to driver housing, lens frame or accessories. Additional delay required. Not compatible with marine grade paint.
  - Marine grade finish for harsh, coastal environment and exposure to salt water. Additional delay required. Please contact factory for info.
  - Available only in WHT and BKT finish.

ARCHITECT / ENGINEER OF RECORD

**MULTI-TENANT BUILDING**  
 7401 MINERAL POINT RD.  
 MADISON, WI 53717

**Project Status**

PROJ. #:	25001-01
© SKETCHWORKS ARCHITECTURE	2025

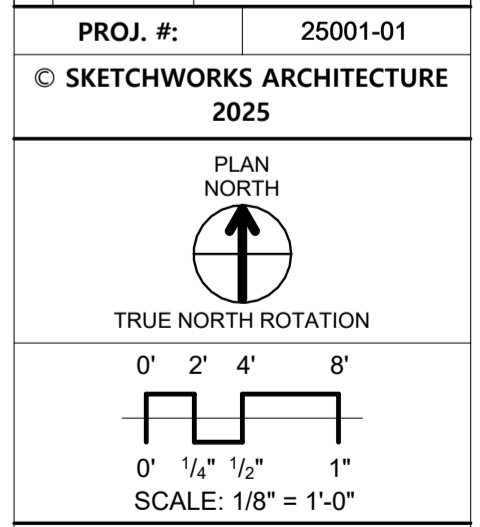

**SITE LIGHTING**

**ES001**

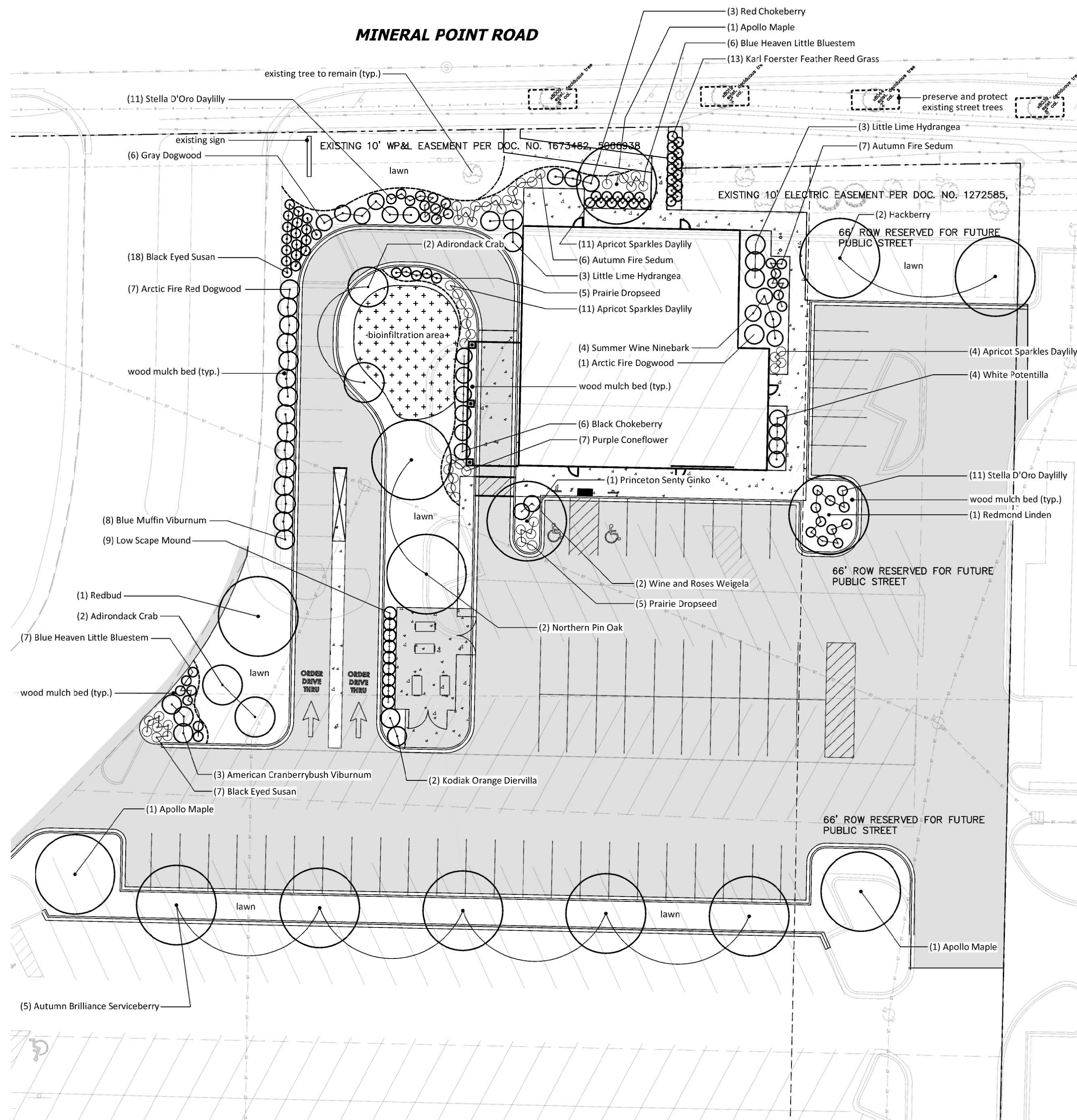

# 1 LANDSCAPE PLAN

1"=20'-0"

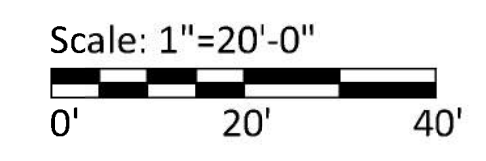

- GENERAL NOTES:**
- Trees and shrub groupings are to receive wood mulch beds consisting of a mixture of recycled wood dyed wood mulch spread to a 3" min. depth over a pre-emergent herbicide.
  - "Lawn" areas shall be finish graded and seeded at a rate of 4 lbs. per 1,000 sq. ft. Basis of Design: Madison Parks Lawn Seed Mix. EarthCarpet Corporation. ([www.seedsolutions.com](http://www.seedsolutions.com))
  - Landscape Contractor shall provide regular maintenance until a date 60 days after completion of planting. Maintenance shall begin when planting is started for ongoing planting areas. Maintenance operations shall include watering, weeding, and mowing. Contractor shall provide temporary irrigation equipment if needed to provide a minimum of 1" of water per week throughout the maintenance period for all planting areas.
  - Landscape Contractor shall guarantee to replace once, without charge, any plant material that dies within one year of installation providing the Owner gives normal plant care (regular watering). The Owner must report plant losses within the guarantee period.
  - Contractor shall take precautions during construction to not disfigure, scar, or impair the health of any street tree. Contractor shall operate equipment in a manner as to not damage the branches of the street tree(s). Any damage or injury to existing street trees (either above or belowground) shall be reported immediately to City Forestry at 266-4816. Penalties and remediation shall be required.
  - As defined by the Section 107.13 of City of Madison Standard Specifications for Public Works Construction: No excavation is permitted within 5 feet of the trunk of the street tree or when cutting roots over 3 inches in diameter. If excavation is necessary, the Contractor shall contact Madison City Forestry (266-4816) prior to excavation. City of Madison Forestry personnel shall assess the impact to the tree and to its root system prior to work commencing. Tree protection specifications can be found on the following website: <https://www.cityofmadison.com/business/pw/specs.cfm>
  - Street tree protection zone fencing is required. The fencing shall be erected before the demolition, grading or construction begins. The fence shall include the entire width of terrace and, extend at least 5 feet on both sides of the outside edge of the tree trunk. Removal of fencing is not allowed for deliveries or equipment access through the tree protection zone.
  - Pruning Street tree pruning shall be coordinated with Madison Forestry at a minimum of two weeks prior to the start of construction for this project. All pruning shall follow the American National Standards Institute (ANSI) A300 - Part 1 Standards for pruning. Add as a note on the plan set.
  - Soil Section 107.13(g) of City of Madison Standard Specifications for Public Works Construction addresses soil compaction near street trees and shall be followed by Contractor. The storage of parked vehicles, construction equipment, building materials, refuse, excavated spoils or dumping of poisonous materials on or around trees and roots within five (5) feet of the tree or within the protection zone is prohibited.
  - An inventory of street trees located within the right of way and to be protected has been included on the landscape plan. It includes the following: location and size of existing street trees.

**Landscape Calculations and Distribution:**  
 Five (5) landscape points shall be provided per each (300) sf of developed area  
 Total sf of developed area = 38,161 sf  
 Developed area divided by (300) x 5 = 636 Points Required

**Development Frontage Landscaping**  
 Total lf of lot frontage = 229  
 Required Trees = 8      Provided Trees = 9 (all existing and numbered; see plan)  
 Required Shrubs = 40      Provided Shrubs = \*\*0

\*\* Owner requests waiver from required shrubs along north development frontage due to multiple existing easements (shown) and easterly 66' of this project site is reserved for public street right of way (see civil).

**Tabulation of Points and Credits (includes Development Frontage Landscaping):**

Plant Type/Element	Min. size	Points	Proposed Qty.	Pts.
Overstory Deciduous Tree	2 1/2" cal.	35	9	315
Ornamental tree	1 1/2" cal.	15	10	150
Upright evergreen shrub	3-4 feet tall	10	-	-
Shrub, deciduous	18" or 3 gal.	3	61	183
Shrub, evergreen	18" or 3 gal.	4	-	-
Ornamental grasses or perennials	18" or 3 gal.	2	125	250
Ornamental fence or wall	na	4 per 10 lf	-	-
<b>Total</b>				<b>898</b>

898 Total Points Provided (636 Required)

**Plant Schedule**

Qty.	Overstory and Ornamental Trees		
1	Redbud	<i>Cercis canadensis</i>	2 1/2" cal.
2	Hackberry	<i>Celtis occidentalis</i>	2 1/2" cal.
2	Northern Pin Oak	<i>Quercus ellipsoidalis</i>	2 1/2" cal.
5	Autumn Brilliance Serviceberry	<i>Amelanchier x grandiflora 'Autumn Brilliance'</i>	2 1/2" cal.
3	Apollo Maple	<i>Acer saccharum 'Barrett Cole'</i>	2 1/2" cal.
1	Redmond Linden	<i>Tilia americana 'Redmond'</i>	2 1/2" cal.
4	Adirondack Crab	<i>Malus Adirondack</i>	2 1/2" cal.
1	Princeton Sentry Ginkgo	<i>Ginkgo biloba 'PNI 2720'</i>	2 1/2" cal.

**Shrubs**

6	Black Chokeberry	<i>Aronia melanocarpa</i>	24" ht.
9	Low Scape Mound	<i>Aronia melanocarpa 'Low Scape Mound'</i>	18" ht.
6	Gray Dogwood	<i>Cornus racemosa</i>	24" ht.
8	Arctic Fire Red Dogwood	<i>Cornus sericea 'Arctic Fire'</i>	24" ht.
2	Kodiak Orange Diervilla	<i>Diervilla 'Kodiak Orange'</i>	18" ht.
6	Little Lime Hydrangea	<i>Hydrangea paniculata 'Little Lime'</i>	24" ht.
4	Summer Wine Ninebark	<i>Physocarpus opulifolius</i>	18" ht.
8	Blue Miffin Viburnum	<i>Viburnum dentatum 'Christom'</i>	24" ht.
4	White Potentilla	<i>Potentilla fruticosa 'McKay's White'</i>	18" ht.
3	American Cranberrybush Viburnum	<i>Viburnum opulus var. americanum</i>	24" ht.
3	Red Chokeberry	<i>Aronia arbutifolia 'Brilliantissima'</i>	24" ht.
2	Wine and Roses Weigela	<i>Weigela florida 'Alexandra'</i>	24" ht.

**Perennials**

25	Black Eyed Susan	<i>Rudbeckia fulgida</i>	1 gal.
7	Purple Coneflower	<i>Echinacea purpurea</i>	1 gal.
13	Blue Heaven Little Bluestem	<i>Schizachyrium scoparium 'Blue Heaven'</i>	1 gal.
13	Karl Foerster Feather Reed Grass	<i>Calamagrostis x acutiflora 'Karl Foerster'</i>	1 gal.
22	Apricot Sparkles Daylily	<i>Hemerocallis 'Apricot Sparkles'</i>	1 gal.
10	Prairie Dropseed	<i>Sporobolus heterolepis</i>	1 gal.
22	Stella D'Oro Daylily	<i>Hemerocallis 'Stella de Oro'</i>	1 gal.
13	Autumn Fire Sedum	<i>Hylotelephium 'Autumn Fire'</i>	1 gal.

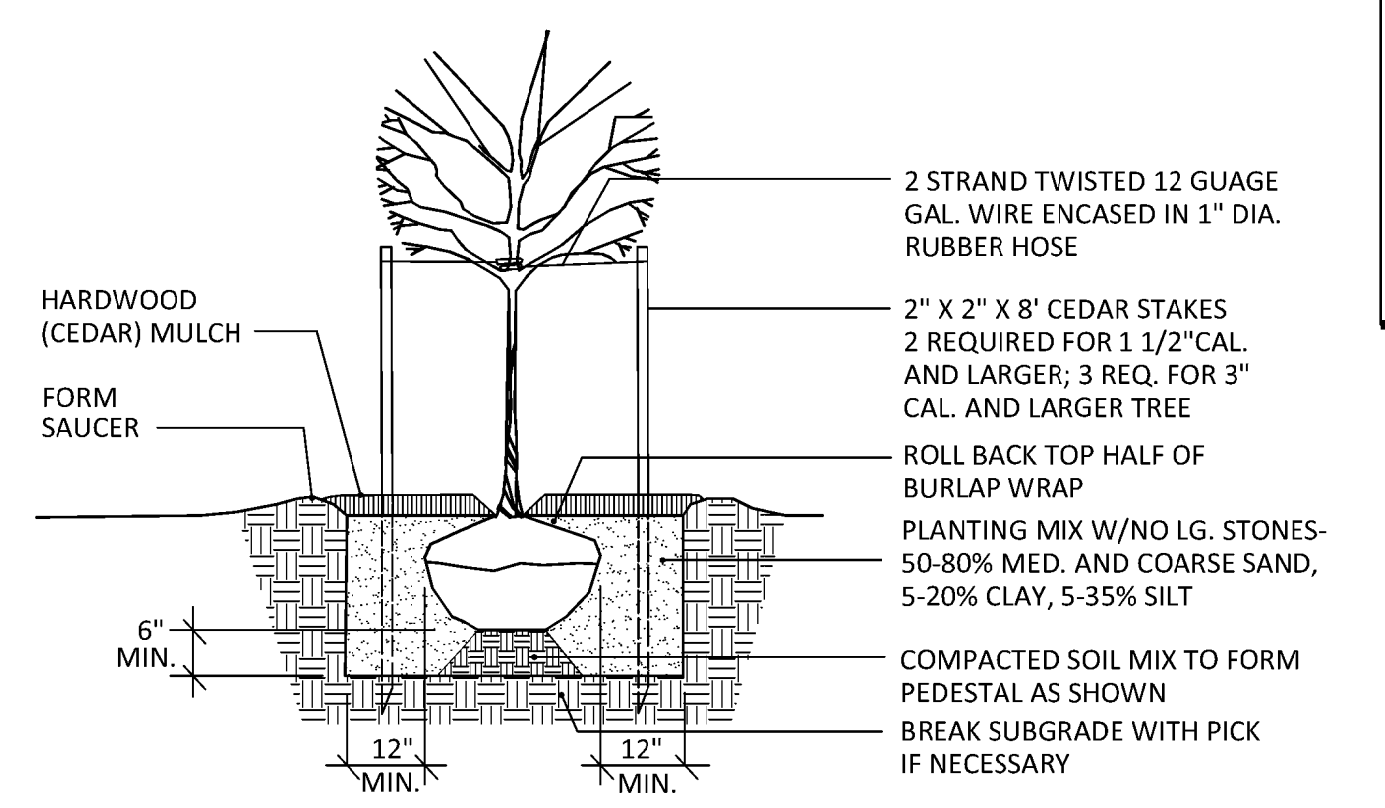

# 2 TREE PLANTING

NTS

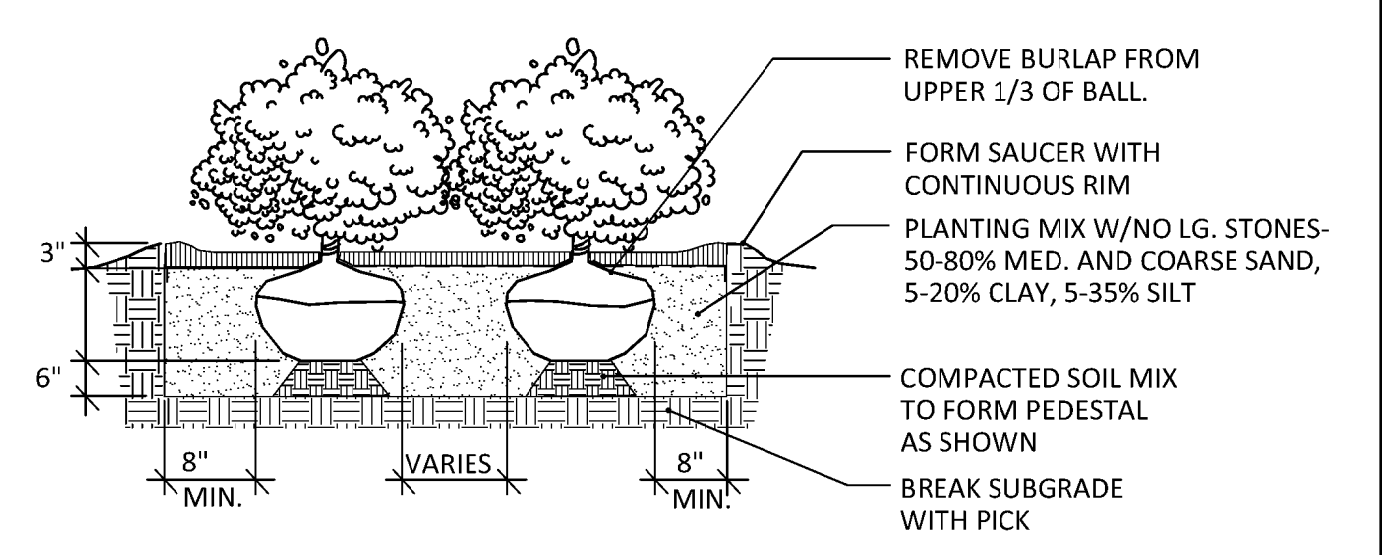

# 3 SHRUB PLANTING

NTS

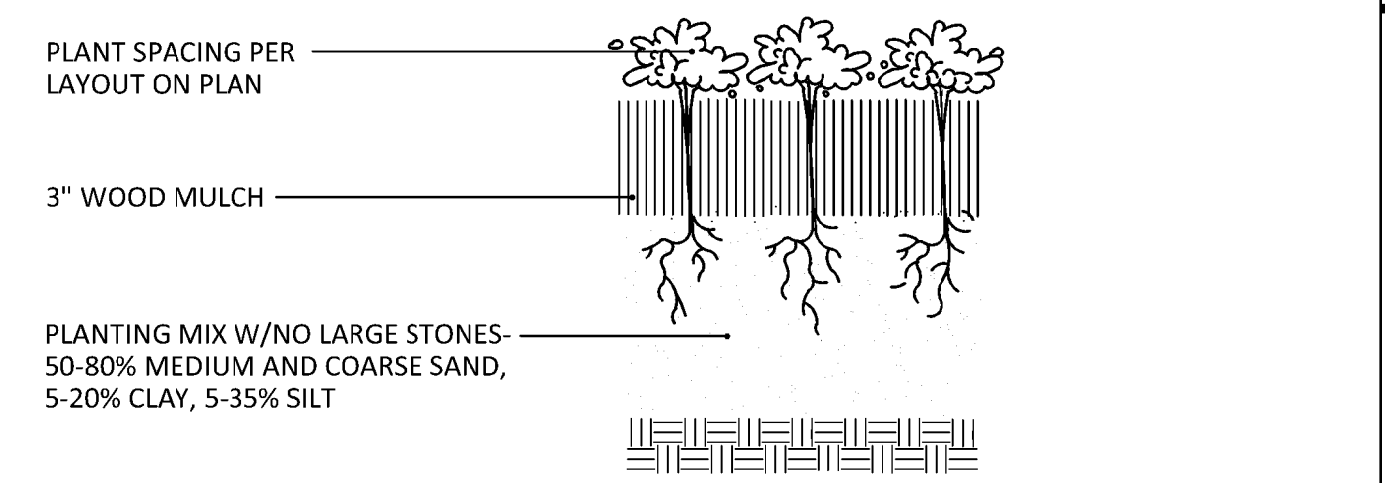

# 4 PERENNIAL PLANTING

NTS

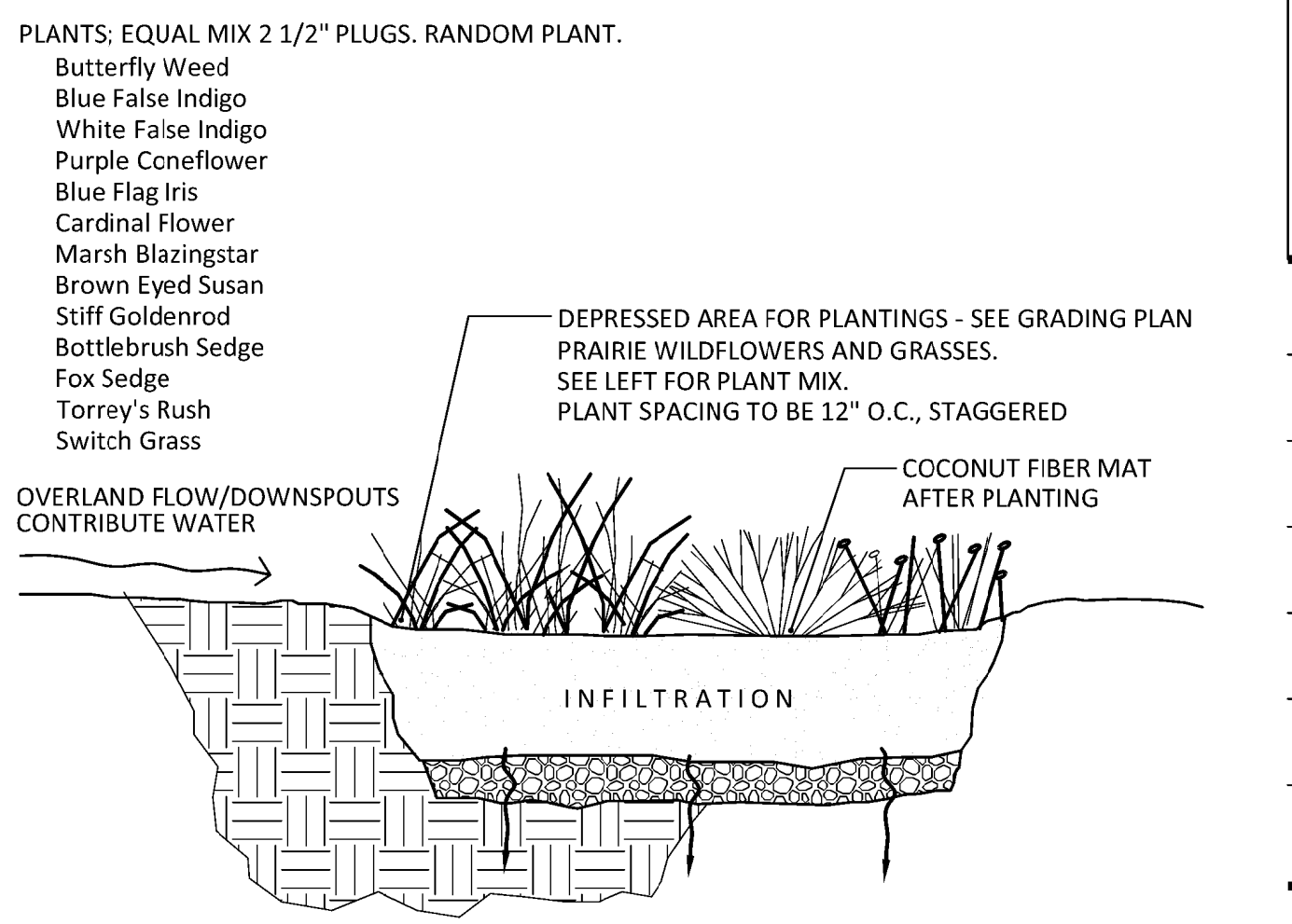

# 5 BIOINFILTRATION AREA

NTS











