

- GENERAL STRUCTURAL NOTES:**
- SEE DESIGN LOADS ON SHEET A6.10 FOR ALL DESIGN LOADS NOT SHOWN ON PLANS.
 - SEE CIVIL PLANS FOR FLOOR ELEVATIONS AT GARAGE OVERHEAD DOOR.
 - TRUSS MANUFACTURER TO PREPARE FINAL FRAMING PLANS FOR THE CONTRACTOR'S USE IN FIELD. NOTIFY ARCHITECT / ENGINEER OF ANY CHANGES.
 - SEE BUILDING CROSS SECTIONS AND DETAILS FOR TRUSS PROFILES.
 - SEE TRUSS MANUFACTURER'S DRAWING FOR WEB & LATERAL BRACING SIZE & LOCATION REQUIREMENTS - BRACING BY D.C.
 - ALL METAL TRUSS HANGERS BY TRUSS MANUFACTURER WHERE REQUIRED.
 - THE NUMBER AND SIZE OF NAILS CONNECTING WOOD MEMBERS SHALL NOT BE LESS THAN THAT SET FORTH IN I.B.C. TABLE 2304.9.1 "FASTENING SCHEDULE" - SEE STRUCTURAL DRAWINGS.
 - PROVIDE FULL DEPTH BLOCKING AT MID HEIGHT OF ALL INTERIOR BEARING WALLS.
 - EXCEPTION: AT INTERIOR BEARING WALLS THAT ARE PRE-SHEATHED BOTH SIDES, WITH SHEATHING FASTENED AT 12" O.C., FULL DEPTH BLOCKING IS NOT REQUIRED.
 - USE (1) "SIMPSON" H2.5T TRUSS ANCHOR @ EACH ROOF TRUSS BEARING LOCATION W/ (5) #8 NAILS INTO TRUSS & (5) #8 NAILS INTO MIN. DOUBLE PLATE.
 - UNLESS NOTED OTHERWISE, NAIL ROOF SHEATHING TO TOP OF ALL GABLE END TRUSSES W/ #4 NAILS @ 8" O.C.
 - UNLESS NOTED OTHERWISE, NAIL ROOF SHEATHING 6" O.C. @ PANEL EDGES W/ #4 NAILS, NAIL 12" O.C. (W.N.) @ INTERMEDIATE SUPPORTS.
 - UNLESS NOTED OTHERWISE, NAIL WALL SHEATHING 6" O.C. @ PANEL EDGES W/ #4 NAILS, NAIL 12" O.C. (W.N.) @ INTERMEDIATE SUPPORTS.
 - * INDICATES LOCATION OF TRUSS/RAFTER BLOCKING.
 - SEE DETAIL D/O FOR TYPICAL 2x BLOCKING AT ROOF TRUSSES WHEN REQUIRED.

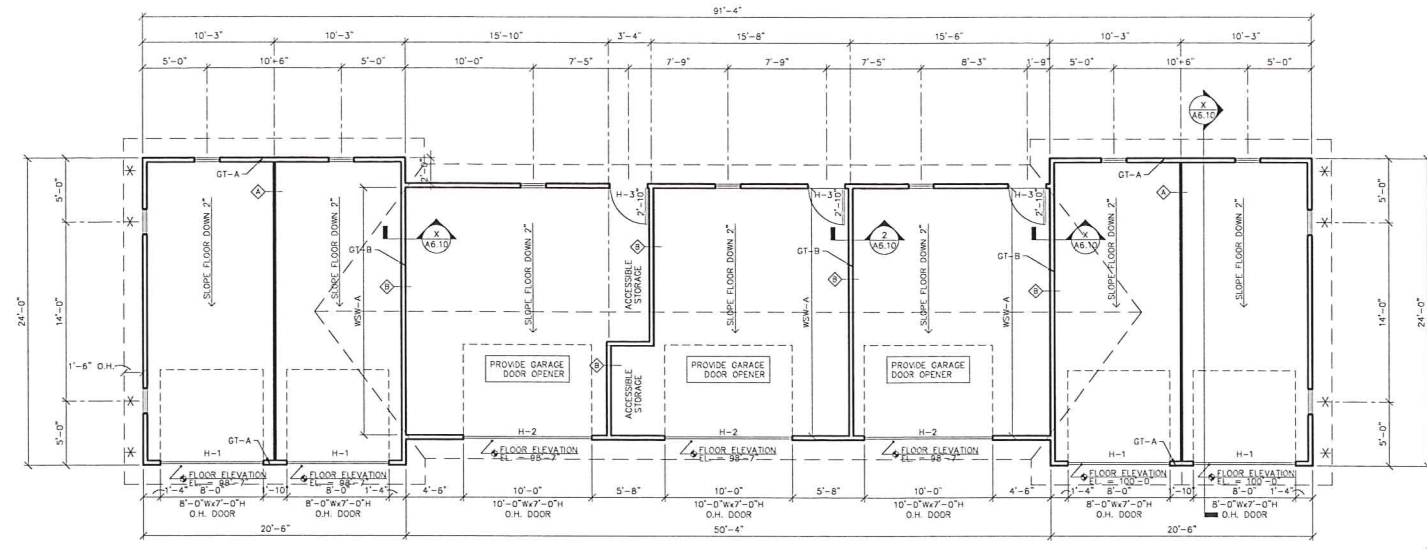

**(7) GARAGES
GARAGE #13 FLOOR PLAN**
SCALE: 3/16" = 1'-0"

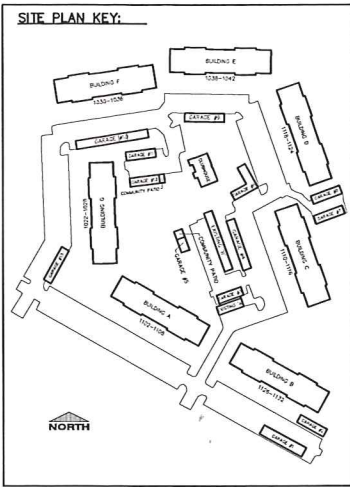
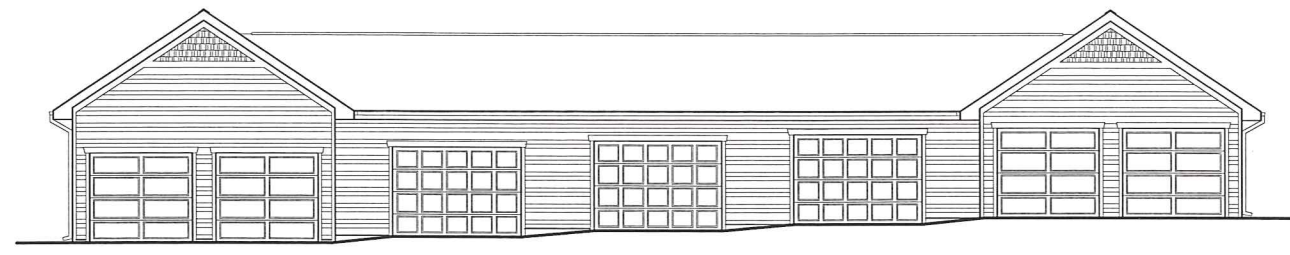

**(7) GARAGES
GARAGE #13 FRONT ELEVATION**
SCALE: 3/16" = 1'-0"

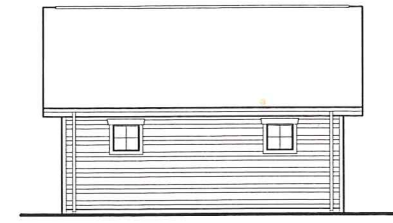

**(7) GARAGES
GARAGE #13 SIDE ELEVATION**
SCALE: 3/16" = 1'-0"

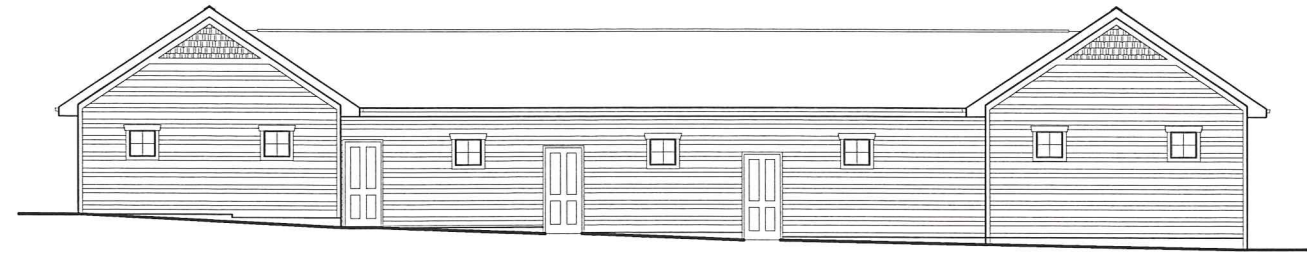

**(7) GARAGES
GARAGE #13 REAR ELEVATION**
SCALE: 3/16" = 1'-0"

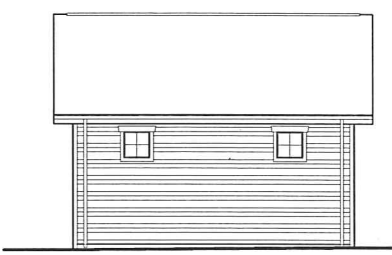

**(7) GARAGES
GARAGE #13 SIDE ELEVATION**
SCALE: 3/16" = 1'-0"

Always a Better Plan

DRAWING SET IDENTIFIER

● PROJECT MASTER SET

- BUILDING 'A'
- BUILDING 'B'
- BUILDING 'C'
- BUILDING 'D'
- BUILDING 'E'
- BUILDING 'F'
- BUILDING 'G'
- BUILDING 'H'
- BUILDING 'I'
- BUILDING 'J'
- BUILDING 'K'
- CLUBHOUSE
- GARAGE #1
- GARAGE #2
- GARAGE #3
- GARAGE #4
- GARAGE #5
- GARAGE #6
- GARAGE #7
- GARAGE #8
- GARAGE #9
- GARAGE #10
- GARAGE #11
- GARAGE #12
- GARAGE #13

ARCHITECT STAMP / SIGNATURE

HUD PROJECT #:
TBD

OWNER:
NOB HILL APARTMENTS LLC
710 NORTH PLANKINTON AVENUE
SUITE 1200
MILWAUKEE, WI 53203

PROJECT:
NOB HILL APARTMENTS
1108 MOORLAND ROAD
MADISON, WI 53713

SHEET ISSUE:
JUNE 26, 2012
SEE TITLE SHEET TO CONFIRM
THAT THIS SHEET HAS BEEN
ISSUED FOR CONSTRUCTION

REVISIONS:

NO.	DESCRIPTION	DATE

JOB NUMBER:
1206230
SHEET

DRAWING SET IDENTIFIER

PROJECT MASTER SET

- BUILDING 'A'
- BUILDING 'B'
- BUILDING 'C'
- BUILDING 'D'
- BUILDING 'E'
- BUILDING 'F'
- BUILDING 'G'
- BUILDING 'H'
- BUILDING 'I'
- BUILDING 'J'
- BUILDING 'K'
- CLUBHOUSE
- GARAGE #1
- GARAGE #2
- GARAGE #3
- GARAGE #4
- GARAGE #5
- GARAGE #6
- GARAGE #7
- GARAGE #8
- GARAGE #9
- GARAGE #10
- GARAGE #11
- GARAGE #12
- GARAGE #13



ARCHITECT STAMP / SIGNATURE

HUD PROJECT #:
TBD

OWNER:
NOB HILL APARTMENTS LLC
710 NORTH PLANKINTON AVENUE
SUITE 1200
MILWAUKEE, WI 53203

PROJECT:
NOB HILL APARTMENTS
1108 MOORLAND ROAD
MADISON, WI 53715

SHEET ISSUE:

JUNE 26, 2012

SEE TITLE SHEET TO CONFIRM
THAT THIS SHEET HAS BEEN
ISSUED FOR CONSTRUCTION

REVISIONS:

JOB NUMBER:

1206230

SHEET

A2.1

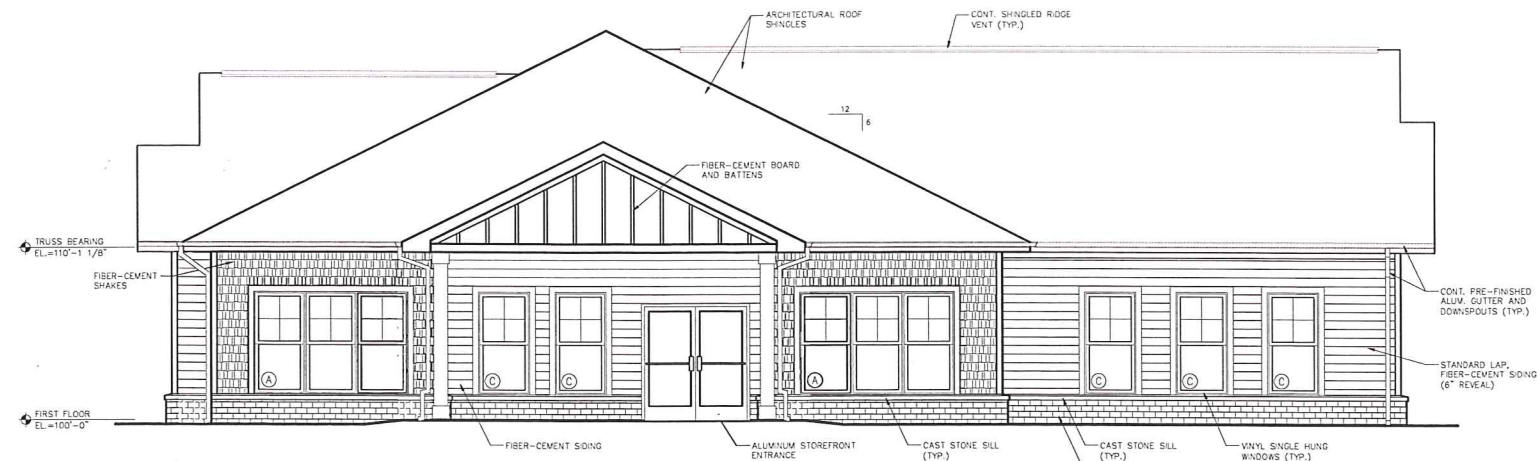

**CLUBHOUSE BLDG.
FRONT ELEVATION**
SCALE: 1/4" = 1'-0"

BROUOF CONTROL JOINT:
- WITHIN 4" OF OUTSIDE CORNERS
- AT ALL INSIDE CORNERS
- SPACED NO MORE THAN 20' APART
- AT BOTH SIDES OF ALL OPENINGS OVER 6' WIDE
- NEAR ONE SIDE OF DOOR AND WINDOW OPENINGS
UNDER 6' WIDE (NOT REQUIRED AT ALL OPENINGS IF
ADJACENT TO BUILDING CORNER CONTROL JOINT)
SEE DETAIL 10/A2.2 FOR TYPICAL CONTROL JOINT

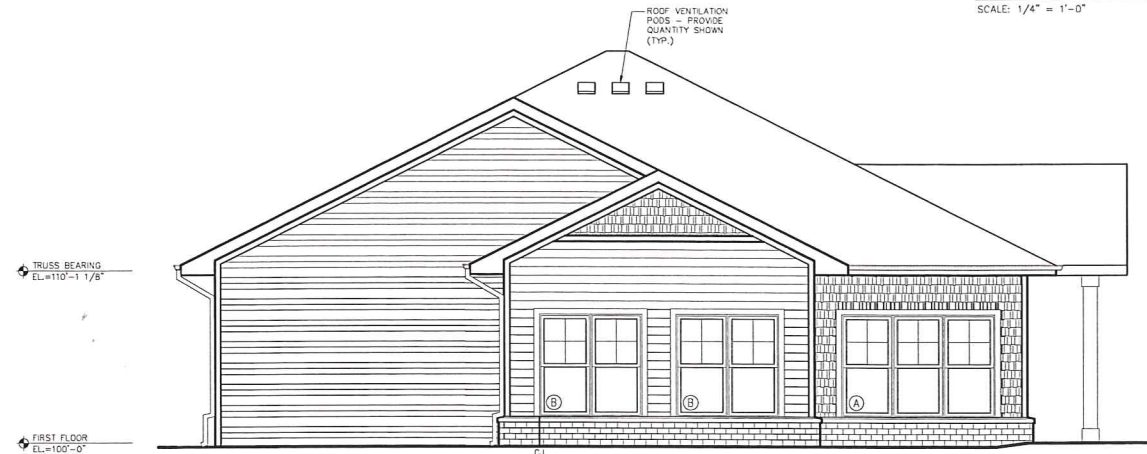

**CLUBHOUSE BLDG.
LEFT SIDE ELEVATION**
SCALE: 1/4" = 1'-0"

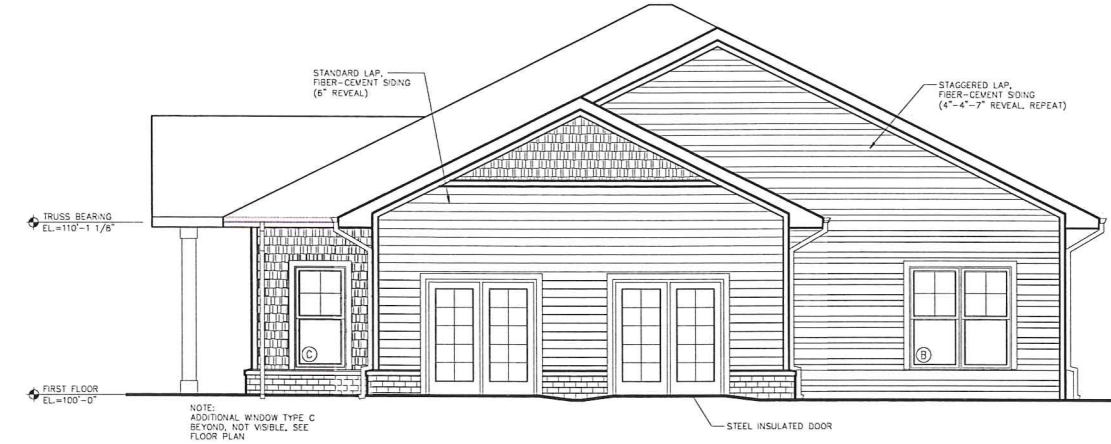

**CLUBHOUSE BLDG.
RIGHT SIDE ELEVATION**
SCALE: 1/4" = 1'-0"

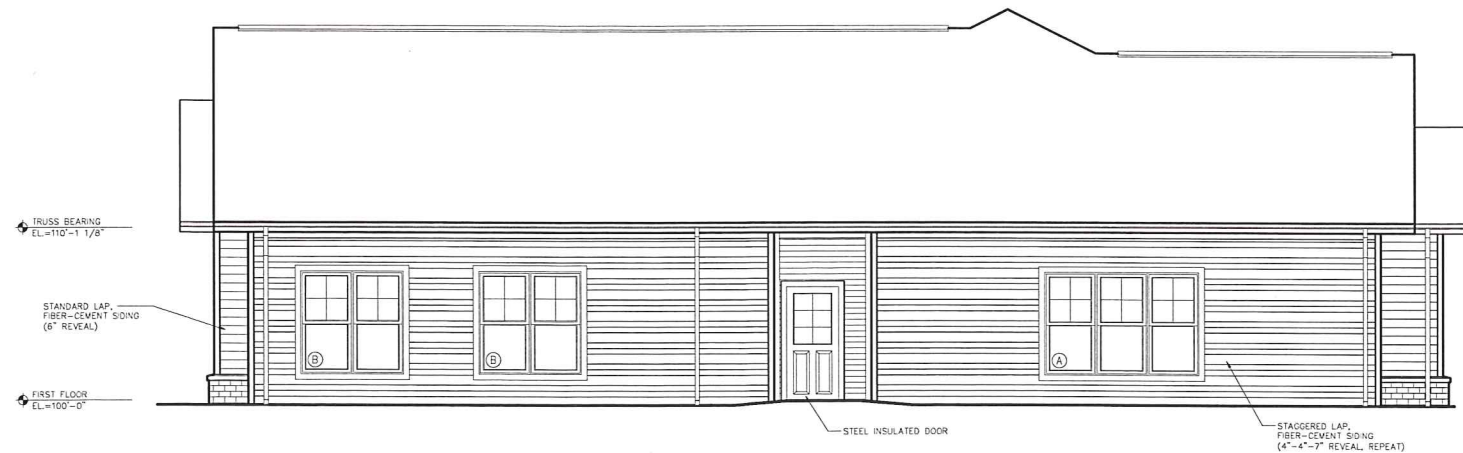

**CLUBHOUSE BLDG.
REAR ELEVATION**
SCALE: 1/4" = 1'-0"

WINDOW SCHEDULE			
SYM.	MATL.	DESCRIPTION	NOM. UNIT SIZE W.x.H.
A	VINYL	(3) SINGLE HUNG WINDOW	3'-0" x 6'-0"
B	VINYL	(2) SINGLE HUNG WINDOW	3'-0" x 6'-0"
C	VINYL	SINGLE HUNG WINDOW	3'-0" x 6'-0"

LOOSE LINTEL (6" END BEARING EACH END)
L 3 1/2x3 1/2x1/4 (WHEN BRICK VENEER ABOVE)
L 3 1/2x3 1/2x1/4 (WHEN BRICK VENEER ABOVE)
L 3 1/2x3 1/2x1/4 (WHEN BRICK VENEER ABOVE)

- ENERGY STAR WINDOWS
- WINDOWS TO HAVE GRILLES BETWEEN GLAZING
- PER IBC 2406.3.6 SAFETY GLAZING ADJACENT TO A DOOR WHERE THE NEAREST EXPOSED EDGE OF THE GLAZING IS WITHIN 24"
- WINDOW MANUFACTURER TO PROVIDE SAFETY GLAZING WHERE REQUIRED BY CODE
- CONTRACTOR TO VERIFY THAT LOOSE LINTEL WILL BE ADEQUATE WIDTH FOR PROPOSED WINDOW PROFILE & WALL CONSTRUCTION



LEGEND **LANDSCAPE MANAGEMENT ZONES**

- EXISTING BUILDINGS TO BE RENOVATED:**

- A. INTENSIVE FOUNDATION PLANTING ZONE:**
 New landscaping introductions to define space, add seasonal interest and create a cohesive experience throughout the development. Higher plant variety in this area.
 1. Mix of evergreen and deciduous shrubs with perennial planting accents.
 2. Add double shredded hardwood mulch, natural color throughout all planting beds, 3" depth.
 3. Shovel cut edges, smooth, continuous radii/lines.
 4. Seasonal aesthetic interest with minimal maintenance. Plantings selected based on durability and tolerance to drought, salt and neglect.
 5. Remove existing vegetation around signage entries and replace with ornamental plantings as indicated.

- B. PRIMARY REJUVENATION PLANTING ZONE:**
 Selectively remove overgrown and aging species. Replace with plantings that add aesthetic character and enhance environmental capabilities (attract wildlife, reduce stormwater, etc.).
 1. See landscape sheets C1.5A, C1.5B, C1.5C for specific plant recommendations.
 2. This zone is located along south and western frontages of buildings. Deciduous canopy vegetation shall be utilized to increase building energy efficiency. Evergreen trees shall be selectively removed to reduce dense shade and afford better sight lines for safety.
 3. Combine planting beds with proposed "Type A" management zone bed lines where indicated.
 4. Remove existing wood mulch and built up debris to bring grade within proximity of adjacent walks.
 5. Add double shredded hardwood mulch, natural color through all planting beds, 3" depth.
 6. Replace dead, damaged or diseased trees/shrubs with like variety.

- C. SECONDARY REJUVENATION PLANTING ZONE:**
 Selectively remove overgrown and aging species with some additions of new shrub material. Areas are confined by single (isolated) species with functional characteristics over ornamental variety. Refresh mulch.
 1. See landscape sheets C1.5A, C1.5B, C1.5C for specific plant recommendations.
 2. Prune and lim up deciduous tree species along Moorland Road in buffer yard area.
 3. Remove "isolated" shrub effect along Moorland Road in buffer yard area. Combine single species or add similar species to create edge buffer.
 4. Selectively remove diseased, damaged or crowding species.
 5. Areas behind units along patios to be maintained. Replace dead, damaged or diseased shrubs with like varieties.
 6. Add double shredded hardwood mulch, natural color through all planting beds, 3" depth.

- D. MATURE DECIDUOUS TREE CANOPY ZONE:**
 Maintain existing landscape aesthetic with large deciduous tree canopies planted in lawn areas. Selectively remove and/or prune if necessary to increase light, enhance views or provide aesthetics.
 1. Perform a tree diagnosis and actions plan to identify health and safety of existing mature trees in lawn areas throughout the site.
 2. Restore lawn or add lawn as indicated on the plans. Slopes of 1:4 or greater shall be stabilized until establishment.
 3. Remove invasive trees.
 4. Provide 6" diameter mulch rings around all trees. Do not place mulch against tree trunks.



* architectural treatments per architectural plans FOCAL ENTRY LANDSCAPE VIGNETTE

Note - Garage placement does not reflect current security & planning department updates.



100 CAMELOT DRIVE
FOND DU LAC, WI 54935
PHONE: (920) 928-8900
FAX: (920) 928-8901

Always a Better Plan

DRAWING SET IDENTIFIER	
PROJECT MASTER SET	
BUILDING A	
BUILDING B	
BUILDING C	
BUILDING D	
BUILDING E	
BUILDING F	
BUILDING G	
CLUBHOUSE	
GARAGE #1	
GARAGE #2	
GARAGE #3	
GARAGE #4	
GARAGE #5	
GARAGE #6	
GARAGE #7	
GARAGE #8	
GARAGE #9	
GARAGE #10	

ARCHITECT STAMP / SIGNATURE

HUD PROJECT #:
TBD

OWNER:
NOB HILL APARTMENTS LLC
710 NORTH PLANKINTON AVENUE
SUITE 1200
MILWAUKEE, WI 53203

PROJECT:
NOB HILL APARTMENTS
1108 MOORLAND ROAD
MADISON, WI 53713

PRELIMINARY SHEET DATES:
JUNE 20, 2012
JULY 18, 2012
SEPT 26, 2012

JOB NUMBER:
1206230

SHEET

C1.5

REQUIREMENTS: BASED ON 483 EXISTING STALLS
 CANOPY TREES REQUIRED = 27
 LANDSCAPE POINTS REQUIRED = 1,630

EXISTING LANDSCAPING CALCULATIONS				
TYPE	LOCATION	QUANTITY	POINT VALUE	TOTAL POINTS
CANOPY TREE 2"-2.5" MIN.	LOCATED WITHIN 50' OF THE EDGE OF THE PARKING LOT.	56	35	(56-27) x 35 = 1,015
DECIDUOUS SHRUB	LOCATED WITHIN 20' OF THE EDGE OF THE PARKING LOT.	70	2	140
EVERGREEN SHRUB	LOCATED WITHIN 20' OF THE EDGE OF THE PARKING LOT.	5	35	175
DECORATIVE FENCE (PER 10')	LOCATED WITHIN 20' OF THE EDGE OF THE PARKING LOT.	840'	5/10'	420
EVERGREEN TREE	LOCATED WITHIN 20' OF THE EDGE OF THE PARKING LOT.	26	15	390
SMALL TREE	LOCATED WITHIN 20' OF THE EDGE OF THE PARKING LOT.	27	15	405
EXISTING TOTAL				2,545

LANDSCAPE NOTES:
 THE EXISTING SITE IS OVER REQUIRED FOR LANDSCAPING POINTS. THE ABOVE POINTS DO NOT TAKE INTO CONSIDERATION ANY OF THE SHRUB PLANTINGS WITHIN THE LISTED PLANTER AREAS ADJACENT TO THE BUILDINGS.

PROPOSED LANDSCAPING CALCULATIONS				
TYPE	LOCATION	QUANTITY	POINT VALUE	TOTAL POINTS
CANOPY TREE 2"-2.5" MIN.	WITHIN LAWN AREAS, ENTRY DRIVES AND PARKING LOT TREE ISLANDS	24	35	840
DECIDUOUS SHRUB	ENTRY SIGNAGE AND FRONT FACADE AREAS	493	2	986
EVERGREEN SHRUB	ENTRY SIGNAGE AND FRONT FACADE AREAS	114	3	342
DECORATIVE FENCE (PER 10')	NO NEW FENCING PROPOSED	NA	NA	NA
EVERGREEN TREE	BEHIND PROPOSED GARAGE AREA	6	15	90
SMALL TREE	ENTRY SIGNAGE	13	15	195
PROPOSED TOTAL				2,453
GRAND TOTAL				4,998



100 CAMELOT DRIVE
 FOND DU LAC, WI 54935
 PHONE: (920) 926-8800
 FAX: (920) 926-8801

Always a Better Plan

DRAWING SET IDENTIFIER

PROJECT MASTER SET
BUILDING 'A'
BUILDING 'B'
BUILDING 'C'
BUILDING 'D'
BUILDING 'E'
BUILDING 'F'
BUILDING 'G'
BUILDING 'H'
BUILDING 'I'
BUILDING 'J'
BUILDING 'K'
BUILDING 'L'
BUILDING 'M'
BUILDING 'N'
BUILDING 'O'
BUILDING 'P'
BUILDING 'Q'
BUILDING 'R'
BUILDING 'S'
BUILDING 'T'
BUILDING 'U'
BUILDING 'V'
BUILDING 'W'
BUILDING 'X'
BUILDING 'Y'
BUILDING 'Z'
BUILDING 'AA'
BUILDING 'AB'
BUILDING 'AC'
BUILDING 'AD'
BUILDING 'AE'
BUILDING 'AF'
BUILDING 'AG'
BUILDING 'AH'
BUILDING 'AI'
BUILDING 'AJ'
BUILDING 'AK'
BUILDING 'AL'
BUILDING 'AM'
BUILDING 'AN'
BUILDING 'AO'
BUILDING 'AP'
BUILDING 'AQ'
BUILDING 'AR'
BUILDING 'AS'
BUILDING 'AT'
BUILDING 'AU'
BUILDING 'AV'
BUILDING 'AW'
BUILDING 'AX'
BUILDING 'AY'
BUILDING 'AZ'
BUILDING 'BA'
BUILDING 'BB'
BUILDING 'BC'
BUILDING 'BD'
BUILDING 'BE'
BUILDING 'BF'
BUILDING 'BG'
BUILDING 'BH'
BUILDING 'BI'
BUILDING 'BJ'
BUILDING 'BK'
BUILDING 'BL'
BUILDING 'BM'
BUILDING 'BN'
BUILDING 'BO'
BUILDING 'BP'
BUILDING 'BQ'
BUILDING 'BR'
BUILDING 'BS'
BUILDING 'BT'
BUILDING 'BU'
BUILDING 'BV'
BUILDING 'BW'
BUILDING 'BX'
BUILDING 'BY'
BUILDING 'BZ'
BUILDING 'CA'
BUILDING 'CB'
BUILDING 'CC'
BUILDING 'CD'
BUILDING 'CE'
BUILDING 'CF'
BUILDING 'CG'
BUILDING 'CH'
BUILDING 'CI'
BUILDING 'CJ'
BUILDING 'CK'
BUILDING 'CL'
BUILDING 'CM'
BUILDING 'CN'
BUILDING 'CO'
BUILDING 'CP'
BUILDING 'CQ'
BUILDING 'CR'
BUILDING 'CS'
BUILDING 'CT'
BUILDING 'CU'
BUILDING 'CV'
BUILDING 'CW'
BUILDING 'CX'
BUILDING 'CY'
BUILDING 'CZ'
BUILDING 'DA'
BUILDING 'DB'
BUILDING 'DC'
BUILDING 'DD'
BUILDING 'DE'
BUILDING 'DF'
BUILDING 'DG'
BUILDING 'DH'
BUILDING 'DI'
BUILDING 'DJ'
BUILDING 'DK'
BUILDING 'DL'
BUILDING 'DM'
BUILDING 'DN'
BUILDING 'DO'
BUILDING 'DP'
BUILDING 'DQ'
BUILDING 'DR'
BUILDING 'DS'
BUILDING 'DT'
BUILDING 'DU'
BUILDING 'DV'
BUILDING 'DW'
BUILDING 'DX'
BUILDING 'DY'
BUILDING 'DZ'
BUILDING 'EA'
BUILDING 'EB'
BUILDING 'EC'
BUILDING 'ED'
BUILDING 'EE'
BUILDING 'EF'
BUILDING 'EG'
BUILDING 'EH'
BUILDING 'EI'
BUILDING 'EJ'
BUILDING 'EK'
BUILDING 'EL'
BUILDING 'EM'
BUILDING 'EN'
BUILDING 'EO'
BUILDING 'EP'
BUILDING 'EQ'
BUILDING 'ER'
BUILDING 'ES'
BUILDING 'ET'
BUILDING 'EU'
BUILDING 'EV'
BUILDING 'EW'
BUILDING 'EX'
BUILDING 'EY'
BUILDING 'EZ'
BUILDING 'FA'
BUILDING 'FB'
BUILDING 'FC'
BUILDING 'FD'
BUILDING 'FE'
BUILDING 'FF'
BUILDING 'FG'
BUILDING 'FH'
BUILDING 'FI'
BUILDING 'FJ'
BUILDING 'FK'
BUILDING 'FL'
BUILDING 'FM'
BUILDING 'FN'
BUILDING 'FO'
BUILDING 'FP'
BUILDING 'FQ'
BUILDING 'FR'
BUILDING 'FS'
BUILDING 'FT'
BUILDING 'FU'
BUILDING 'FV'
BUILDING 'FW'
BUILDING 'FX'
BUILDING 'FY'
BUILDING 'FZ'
BUILDING 'GA'
BUILDING 'GB'
BUILDING 'GC'
BUILDING 'GD'
BUILDING 'GE'
BUILDING 'GF'
BUILDING 'GG'
BUILDING 'GH'
BUILDING 'GI'
BUILDING 'GJ'
BUILDING 'GK'
BUILDING 'GL'
BUILDING 'GM'
BUILDING 'GN'
BUILDING 'GO'
BUILDING 'GP'
BUILDING 'GQ'
BUILDING 'GR'
BUILDING 'GS'
BUILDING 'GT'
BUILDING 'GU'
BUILDING 'GV'
BUILDING 'GW'
BUILDING 'GX'
BUILDING 'GY'
BUILDING 'GZ'
BUILDING 'HA'
BUILDING 'HB'
BUILDING 'HC'
BUILDING 'HD'
BUILDING 'HE'
BUILDING 'HF'
BUILDING 'HG'
BUILDING 'HH'
BUILDING 'HI'
BUILDING 'HJ'
BUILDING 'HK'
BUILDING 'HL'
BUILDING 'HM'
BUILDING 'HN'
BUILDING 'HO'
BUILDING 'HP'
BUILDING 'HQ'
BUILDING 'HR'
BUILDING 'HS'
BUILDING 'HT'
BUILDING 'HU'
BUILDING 'HV'
BUILDING 'HW'
BUILDING 'HX'
BUILDING 'HY'
BUILDING 'HZ'
BUILDING 'IA'
BUILDING 'IB'
BUILDING 'IC'
BUILDING 'ID'
BUILDING 'IE'
BUILDING 'IF'
BUILDING 'IG'
BUILDING 'IH'
BUILDING 'II'
BUILDING 'IJ'
BUILDING 'IK'
BUILDING 'IL'
BUILDING 'IM'
BUILDING 'IN'
BUILDING 'IO'
BUILDING 'IP'
BUILDING 'IQ'
BUILDING 'IR'
BUILDING 'IS'
BUILDING 'IT'
BUILDING 'IU'
BUILDING 'IV'
BUILDING 'IW'
BUILDING 'IX'
BUILDING 'IY'
BUILDING 'IZ'
BUILDING 'JA'
BUILDING 'JB'
BUILDING 'JC'
BUILDING 'JD'
BUILDING 'JE'
BUILDING 'JF'
BUILDING 'JG'
BUILDING 'JH'
BUILDING 'JI'
BUILDING 'JJ'
BUILDING 'JK'
BUILDING 'JL'
BUILDING 'JM'
BUILDING 'JN'
BUILDING 'JO'
BUILDING 'JP'
BUILDING 'JQ'
BUILDING 'JR'
BUILDING 'JS'
BUILDING 'JT'
BUILDING 'JU'
BUILDING 'JV'
BUILDING 'JW'
BUILDING 'JX'
BUILDING 'JY'
BUILDING 'JZ'
BUILDING 'KA'
BUILDING 'KB'
BUILDING 'KC'
BUILDING 'KD'
BUILDING 'KE'
BUILDING 'KF'
BUILDING 'KG'
BUILDING 'KH'
BUILDING 'KI'
BUILDING 'KJ'
BUILDING 'KL'
BUILDING 'KM'
BUILDING 'KN'
BUILDING 'KO'
BUILDING 'KP'
BUILDING 'KQ'
BUILDING 'KR'
BUILDING 'KS'
BUILDING 'KT'
BUILDING 'KU'
BUILDING 'KV'
BUILDING 'KW'
BUILDING 'KX'
BUILDING 'KY'
BUILDING 'KZ'
BUILDING 'LA'
BUILDING 'LB'
BUILDING 'LC'
BUILDING 'LD'
BUILDING 'LE'
BUILDING 'LF'
BUILDING 'LG'
BUILDING 'LH'
BUILDING 'LI'
BUILDING 'LJ'
BUILDING 'LK'
BUILDING 'LL'
BUILDING 'LM'
BUILDING 'LN'
BUILDING 'LO'
BUILDING 'LP'
BUILDING 'LQ'
BUILDING 'LR'
BUILDING 'LS'
BUILDING 'LT'
BUILDING 'LU'
BUILDING 'LV'
BUILDING 'LW'
BUILDING 'LX'
BUILDING 'LY'
BUILDING 'LZ'
BUILDING 'MA'
BUILDING 'MB'
BUILDING 'MC'
BUILDING 'MD'
BUILDING 'ME'
BUILDING 'MF'
BUILDING 'MG'
BUILDING 'MH'
BUILDING 'MI'
BUILDING 'MJ'
BUILDING 'MK'
BUILDING 'ML'
BUILDING 'MM'
BUILDING 'MN'
BUILDING 'MO'
BUILDING 'MP'
BUILDING 'MQ'
BUILDING 'MR'
BUILDING 'MS'
BUILDING 'MT'
BUILDING 'MU'
BUILDING 'MV'
BUILDING 'MW'
BUILDING 'MX'
BUILDING 'MY'
BUILDING 'MZ'
BUILDING 'NA'
BUILDING 'NB'
BUILDING 'NC'
BUILDING 'ND'
BUILDING 'NE'
BUILDING 'NF'
BUILDING 'NG'
BUILDING 'NH'
BUILDING 'NI'
BUILDING 'NJ'
BUILDING 'NK'
BUILDING 'NL'
BUILDING 'NM'
BUILDING 'NN'
BUILDING 'NO'
BUILDING 'NP'
BUILDING 'NQ'
BUILDING 'NR'
BUILDING 'NS'
BUILDING 'NT'
BUILDING 'NU'
BUILDING 'NV'
BUILDING 'NW'
BUILDING 'NX'
BUILDING 'NY'
BUILDING 'NZ'
BUILDING 'OA'
BUILDING 'OB'
BUILDING 'OC'
BUILDING 'OD'
BUILDING 'OE'
BUILDING 'OF'
BUILDING 'OG'
BUILDING 'OH'
BUILDING 'OI'
BUILDING 'OJ'
BUILDING 'OK'
BUILDING 'OL'
BUILDING 'OM'
BUILDING 'ON'
BUILDING 'OO'
BUILDING 'OP'
BUILDING 'OQ'
BUILDING 'OR'
BUILDING 'OS'
BUILDING 'OT'
BUILDING 'OU'
BUILDING 'OV'
BUILDING 'OW'
BUILDING 'OX'
BUILDING 'OY'
BUILDING 'OZ'
BUILDING 'PA'
BUILDING 'PB'
BUILDING 'PC'
BUILDING 'PD'
BUILDING 'PE'
BUILDING 'PF'
BUILDING 'PG'
BUILDING 'PH'
BUILDING 'PI'
BUILDING 'PJ'
BUILDING 'PK'
BUILDING 'PL'
BUILDING 'PM'
BUILDING 'PN'
BUILDING 'PO'
BUILDING 'PP'
BUILDING 'PQ'
BUILDING 'PR'
BUILDING 'PS'
BUILDING 'PT'
BUILDING 'PU'
BUILDING 'PV'
BUILDING 'PW'
BUILDING 'PX'
BUILDING 'PY'
BUILDING 'PZ'
BUILDING 'QA'
BUILDING 'QB'
BUILDING 'QC'
BUILDING 'QD'
BUILDING 'QE'
BUILDING 'QF'
BUILDING 'QG'
BUILDING 'QH'
BUILDING 'QI'
BUILDING 'QJ'
BUILDING 'QK'
BUILDING 'QL'
BUILDING 'QM'
BUILDING 'QN'
BUILDING 'QO'
BUILDING 'QP'
BUILDING 'QQ'
BUILDING 'QR'
BUILDING 'QS'
BUILDING 'QT'
BUILDING 'QU'
BUILDING 'QV'
BUILDING 'QW'
BUILDING 'QX'
BUILDING 'QY'
BUILDING 'QZ'
BUILDING 'RA'
BUILDING 'RB'
BUILDING 'RC'
BUILDING 'RD'
BUILDING 'RE'
BUILDING 'RF'
BUILDING 'RG'
BUILDING 'RH'
BUILDING 'RI'
BUILDING 'RJ'
BUILDING 'RK'
BUILDING 'RL'
BUILDING 'RM'
BUILDING 'RN'
BUILDING 'RO'
BUILDING 'RP'
BUILDING 'RQ'
BUILDING 'RR'
BUILDING 'RS'
BUILDING 'RT'
BUILDING 'RU'
BUILDING 'RV'
BUILDING 'RW'
BUILDING 'RX'
BUILDING 'RY'
BUILDING 'RZ'
BUILDING 'SA'
BUILDING 'SB'
BUILDING 'SC'
BUILDING 'SD'
BUILDING 'SE'
BUILDING 'SF'
BUILDING 'SG'
BUILDING 'SH'
BUILDING 'SI'
BUILDING 'SJ'
BUILDING 'SK'
BUILDING 'SL'
BUILDING 'SM'
BUILDING 'SN'
BUILDING 'SO'
BUILDING 'SP'
BUILDING 'SQ'
BUILDING 'SR'
BUILDING 'SS'
BUILDING 'ST'
BUILDING 'SU'
BUILDING 'SV'
BUILDING 'SW'
BUILDING 'SX'
BUILDING 'SY'
BUILDING 'SZ'
BUILDING 'TA'
BUILDING 'TB'
BUILDING 'TC'
BUILDING 'TD'
BUILDING 'TE'
BUILDING 'TF'
BUILDING 'TG'
BUILDING 'TH'
BUILDING 'TI'
BUILDING 'TJ'
BUILDING 'TK'
BUILDING 'TL'
BUILDING 'TM'
BUILDING 'TN'
BUILDING 'TO'
BUILDING 'TP'
BUILDING 'TQ'
BUILDING 'TR'
BUILDING 'TS'
BUILDING 'TT'
BUILDING 'TU'
BUILDING 'TV'
BUILDING 'TW'
BUILDING 'TX'
BUILDING 'TY'
BUILDING 'TZ'
BUILDING 'UA'
BUILDING 'UB'
BUILDING 'UC'
BUILDING 'UD'
BUILDING 'UE'
BUILDING 'UF'
BUILDING 'UG'
BUILDING 'UH'
BUILDING 'UI'
BUILDING 'UJ'
BUILDING 'UK'
BUILDING 'UL'
BUILDING 'UM'
BUILDING 'UN'
BUILDING 'UO'
BUILDING 'UP'
BUILDING 'UQ'
BUILDING 'UR'
BUILDING 'US'
BUILDING 'UT'
BUILDING 'UU'
BUILDING 'UV'
BUILDING 'UW'
BUILDING 'UX'
BUILDING 'UY'
BUILDING 'UZ'
BUILDING 'VA'
BUILDING 'VB'
BUILDING 'VC'
BUILDING 'VD'
BUILDING 'VE'
BUILDING 'VF'
BUILDING 'VG'
BUILDING 'VH'
BUILDING 'VI'
BUILDING 'VJ'
BUILDING 'VK'
BUILDING 'VL'
BUILDING 'VM'
BUILDING 'VN'
BUILDING 'VO'
BUILDING 'VP'
BUILDING 'VQ'
BUILDING 'VR'
BUILDING 'VS'
BUILDING 'VT'
BUILDING 'VU'
BUILDING 'VV'
BUILDING 'VW'
BUILDING 'VX'
BUILDING 'VY'
BUILDING 'VZ'
BUILDING 'WA'
BUILDING 'WB'
BUILDING 'WC'
BUILDING 'WD'
BUILDING 'WE'
BUILDING 'WF'
BUILDING 'WG'
BUILDING 'WH'
BUILDING 'WI'
BUILDING 'WJ'
BUILDING 'WK'
BUILDING 'WL'
BUILDING 'WM'
BUILDING 'WN'
BUILDING 'WO'
BUILDING 'WP'
BUILDING 'WQ'
BUILDING 'WR'
BUILDING 'WS'
BUILDING 'WT'
BUILDING 'WU'
BUILDING 'WV'
BUILDING 'WW'
BUILDING 'WX'
BUILDING 'WY'
BUILDING 'WZ'
BUILDING 'XA'
BUILDING 'XB'
BUILDING 'XC'
BUILDING 'XD'
BUILDING 'XE'
BUILDING 'XF'
BUILDING 'XG'
BUILDING 'XH'
BUILDING 'XI'
BUILDING 'XJ'
BUILDING 'XK'
BUILDING 'XL'
BUILDING 'XM'
BUILDING 'XN'
BUILDING 'XO'
BUILDING 'XP'
BUILDING 'XQ'
BUILDING 'XR'
BUILDING 'XS'
BUILDING 'XT'
BUILDING 'XU'
BUILDING 'XV'
BUILDING 'XW'
BUILDING 'XX'
BUILDING 'XY'
BUILDING 'XZ'
BUILDING 'YA'
BUILDING 'YB'
BUILDING 'YC'
BUILDING 'YD'
BUILDING 'YE'
BUILDING 'YF'
BUILDING 'YG'
BUILDING 'YH'
BUILDING 'YI'
BUILDING 'YJ'
BUILDING 'YK'
BUILDING 'YL'
BUILDING 'YM'
BUILDING 'YN'
BUILDING 'YO'
BUILDING 'YP'
BUILDING 'YQ'
BUILDING 'YR'
BUILDING 'YS'
BUILDING 'YT'
BUILDING 'YU'
BUILDING 'YV'
BUILDING 'YW'
BUILDING 'YX'
BUILDING 'YY'
BUILDING 'YZ'
BUILDING 'ZA'
BUILDING 'ZB'
BUILDING 'ZC'
BUILDING 'ZD'
BUILDING 'ZE'
BUILDING 'ZF'
BUILDING 'ZG'
BUILDING 'ZH'
BUILDING 'ZI'
BUILDING 'ZJ'
BUILDING 'ZK'
BUILDING 'ZL'
BUILDING 'ZM'
BUILDING 'ZN'
BUILDING 'ZO'
BUILDING 'ZP'
BUILDING 'ZQ'
BUILDING 'ZR'
BUILDING 'ZS'
BUILDING 'ZT'
BUILDING 'ZU'
BUILDING 'ZV'
BUILDING 'ZW'
BUILDING 'ZX'
BUILDING 'ZY'
BUILDING 'ZZ'

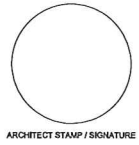

HUD PROJECT #: TBD

OWNER:
 NOB HILL APARTMENTS LLC
 710 NORTH PLANKINGTON AVENUE
 SUITE 1200
 MILWAUKEE, WI 53203

PROJECT:
 NOB HILL APARTMENTS
 1108 MOORLAND ROAD
 MADISON, WI 53713

PRELIMINARY SHEET DATES:
 JUNE 20, 2012
 JULY 18, 2012
 SEPT 26, 2012

JOB NUMBER:
 1206230
 SHEET

C1.5A

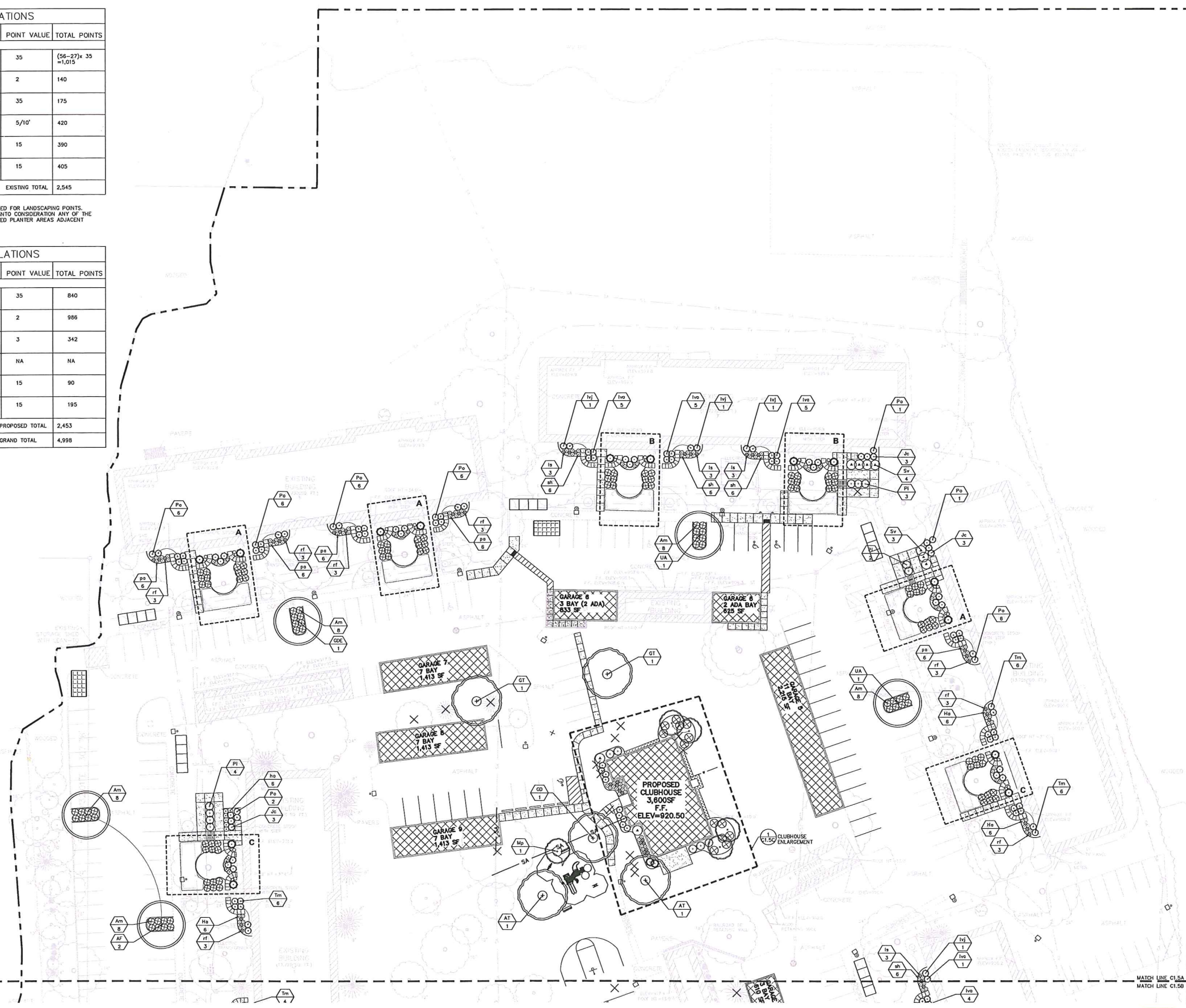

MATCH LINE C1.5A
 MATCH LINE C1.5B

MATCH LINE C1.5A
 MATCH LINE C1.5B

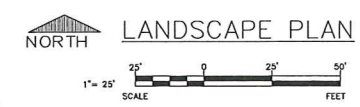

SAA DESIGN GROUP
 SAA Design Group, Inc.<

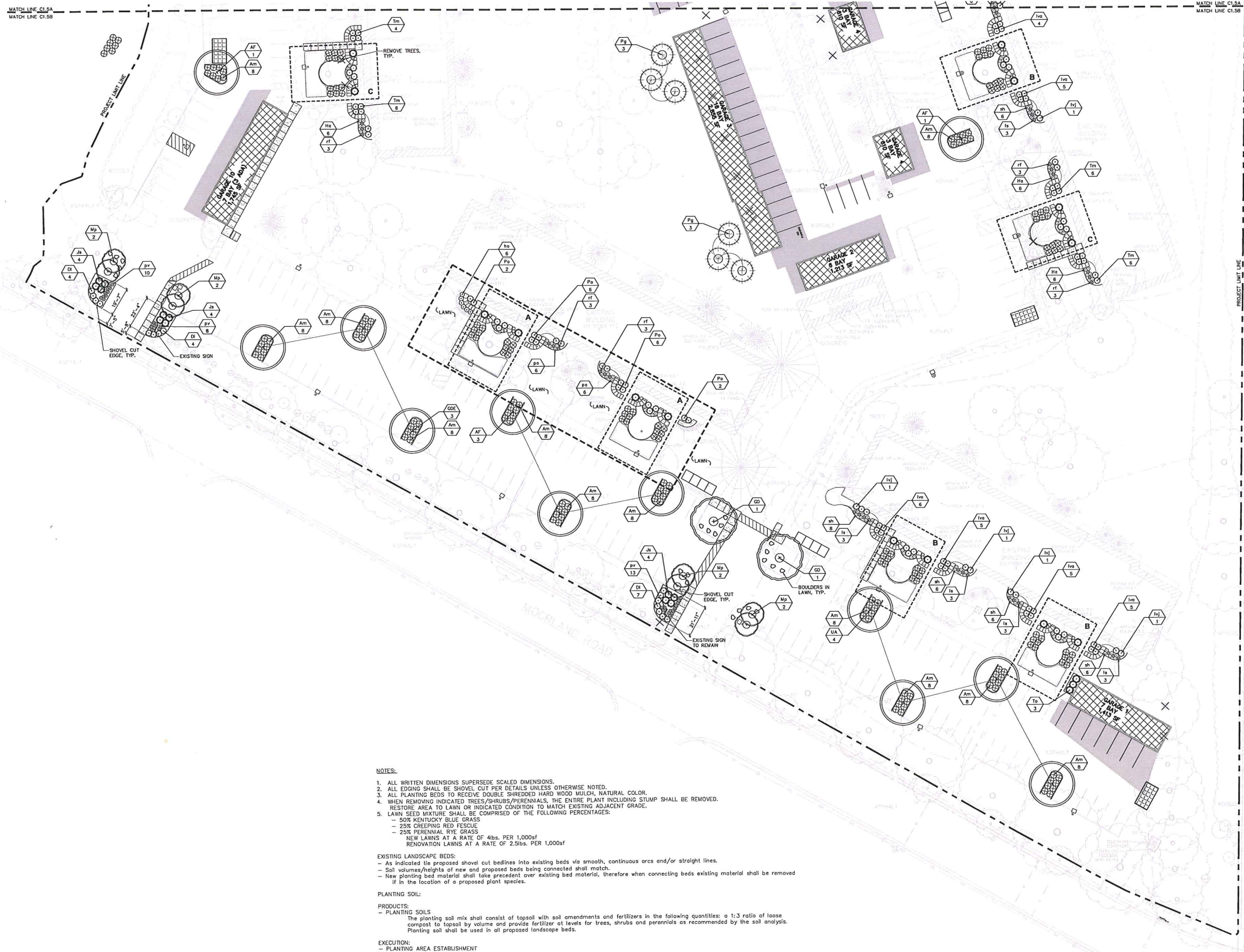

- NOTES:**
1. ALL WRITTEN DIMENSIONS SUPERSEDE SCALED DIMENSIONS.
 2. ALL EDGING SHALL BE SHOVEL CUT PER DETAILS UNLESS OTHERWISE NOTED.
 3. ALL PLANTING BEDS TO RECEIVE DOUBLE SHREDDED HARD WOOD MULCH, NATURAL COLOR.
 4. WHEN REMOVING INDICATED TREES/SHRUBS/PERENNIALS, THE ENTIRE PLANT INCLUDING STUMP SHALL BE REMOVED. RESTORE AREA TO LAWN OR INDICATED CONDITION TO MATCH EXISTING ADJACENT GRADE.
 5. LAWN SEED MIXTURE SHALL BE COMPRISED OF THE FOLLOWING PERCENTAGES:
 - 50% KENTUCKY BLUE GRASS
 - 25% CREEPING RED FESCUE
 - 25% PERENNIAL RYE GRASS
 NEW LAWNS AT A RATE OF 4lbs. PER 1,000sf
 RENOVATION LAWNS AT A RATE OF 2.5lbs. PER 1,000sf

EXISTING LANDSCAPE BEDS:

- As indicated tie proposed shovel cut bedlines into existing beds via smooth, continuous arcs and/or straight lines.
- Soil volumes/heights of new and proposed beds being connected shall match.
- New planting bed material shall take precedent over existing bed material, therefore when connecting beds existing material shall be removed if in the location of a proposed plant species.

PLANTING SOIL:

PRODUCTS:

- PLANTING SOILS

The planting soil mix shall consist of topsoil with soil amendments and fertilizers in the following quantities: a 1:3 ratio of loose compost to topsoil by volume and provide fertilizer at levels for trees, shrubs and perennials as recommended by the soil analysis. Planting soil shall be used in all proposed landscape beds.

EXECUTION:

- PLANTING AREA ESTABLISHMENT
 - Remove sod as necessary.
 - Loosen subgrade of planting areas to a minimum of 8". Remove stones larger than 1" in any dimension and sticks, roots, rubbish, or other extraneous material and legally dispose of off property.
 - Thoroughly blend planting soil off-site before spreading. Spread topsoil, apply soil amendments and fertilizer on surface, and thoroughly blend planting soil.
 - Delay mixing fertilizer with planting soil if planting will not proceed within three days.
 - Spread planting soil mix to a depth of 8" but not less than required to meet finish grades after natural settlement. Do not spread if planting soil or subgrade is frozen, muddy, or excessively wet.
 - Spread approx. 4" of planting soil over loosened subgrade. Mix into top 4" of subgrade. Spread remainder of soil.
- Finish Grading: Grade planting areas to a smooth, uniform surface plane with loose, uniformly fine texture. Roll and rake, remove ridges, and fill depressions to meet finish grades.

Before planting restore planting areas if eroded or otherwise disturbed after finish grading.

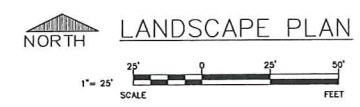

SAA DESIGN GROUP
 SAA Design Group, Inc.
 101 E. Dodge Road
 Madison, WI 53713
 P. 608.255.0900
 F. 608.255.0750
 www.saa-design.com

EXCEL ENGINEERING, INC.
 100 CAMELOT DRIVE
 FOND DU LAC, WI 54935
 PHONE: (920) 926-9000
 FAX: (920) 938-9800

Always a Better Plan

DRAWING SET IDENTIFIER

PROJECT MASTER SET
BUILDING 'A'
BUILDING 'B'
BUILDING 'C'
BUILDING 'D'
BUILDING 'E'
BUILDING 'F'
BUILDING 'G'
BUILDING 'H'
CLUBHOUSE
GARAGE #1
GARAGE #2
GARAGE #3
GARAGE #4
GARAGE #5
GARAGE #6
GARAGE #7
GARAGE #8
GARAGE #9
GARAGE #10

ARCHITECT STAMP / SIGNATURE

HUD PROJECT #:
 TBD

OWNER:
 NOB HILL APARTMENTS LLC
 710 NORTH PLANKINTON AVENUE
 SUITE 1200
 MILWAUKEE, WI 53203

PROJECT:
 NOB HILL APARTMENTS
 1108 MOORLAND ROAD
 MADISON, WI 53713

PRELIMINARY SHEET DATES:
 JUNE 20, 2012
 JULY 18, 2012
 SEPT 26, 2012

JOB NUMBER:
 1206230

SHEET

C1.5B

Always a Better Plan

DRAWING SET IDENTIFIER

PROJECT MASTER SET
BUILDING A*
BUILDING B*
BUILDING C*
BUILDING D*
BUILDING E*
BUILDING F*
BUILDING G*
BUILDING H*
BUILDING I*
CLUBHOUSE
GARAGE #1
GARAGE #2
GARAGE #3
GARAGE #4
GARAGE #5
GARAGE #6
GARAGE #7
GARAGE #8
GARAGE #9
GARAGE #10

ARCHITECT STAMP / SIGNATURE

HUD PROJECT #:
TBD

OWNER:
 NOB HILL APARTMENTS LLC
 710 NORTH PLANKINTON AVENUE
 SUITE 1200
 MILWAUKEE, WI 53203

PROJECT:
 NOB HILL APARTMENTS
 1108 MOORLAND ROAD
 MADISON, WI 53713

PRELIMINARY SHEET DATES:
 JUNE 20, 2012
 JULY 18, 2012
 SEPT 26, 2012

JOB NUMBER:
1206230

SHEET

C1.5C

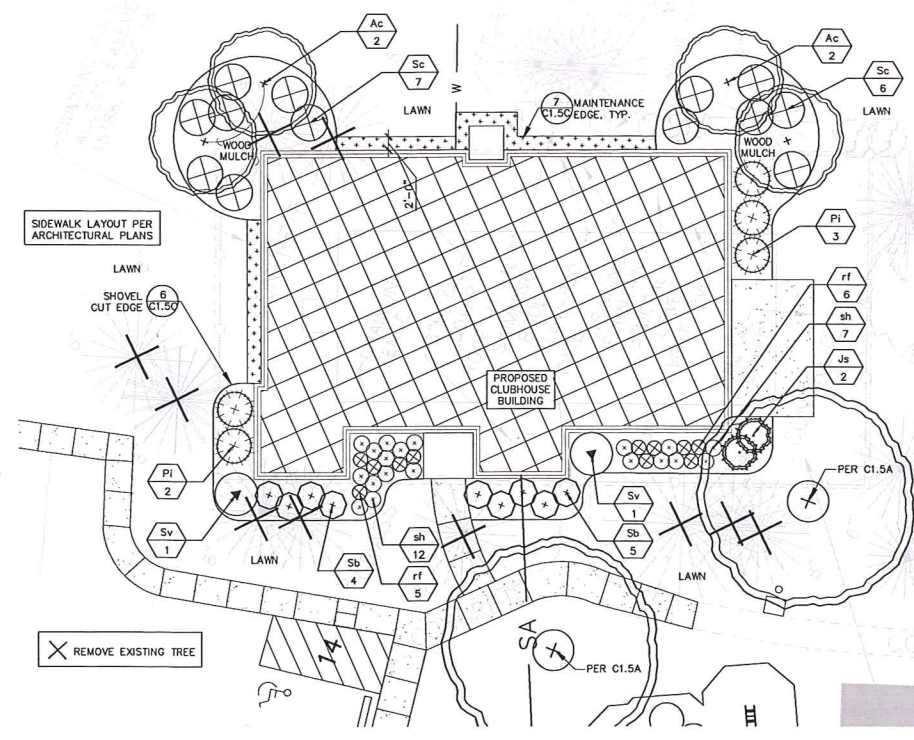

1 CLUBHOUSE ENLARGEMENT
 C1.5C SCALE: 1"=10'-0"

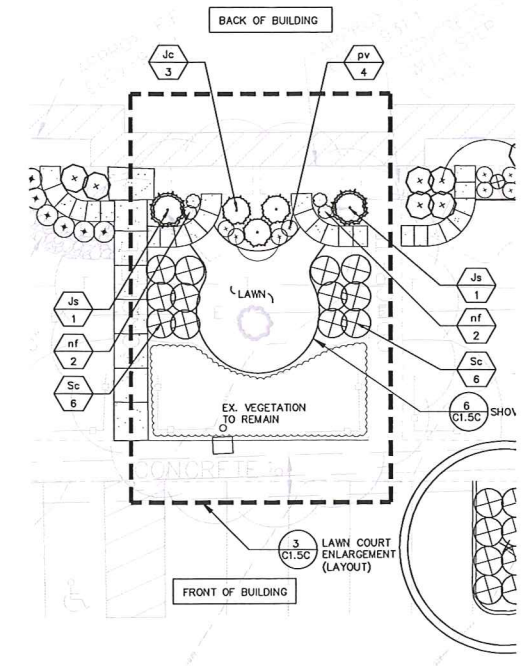

2A BUILDING FRONT YARDS - A
 C1.5C TYPICAL OF 5 SCALE: 1"=10'-0"

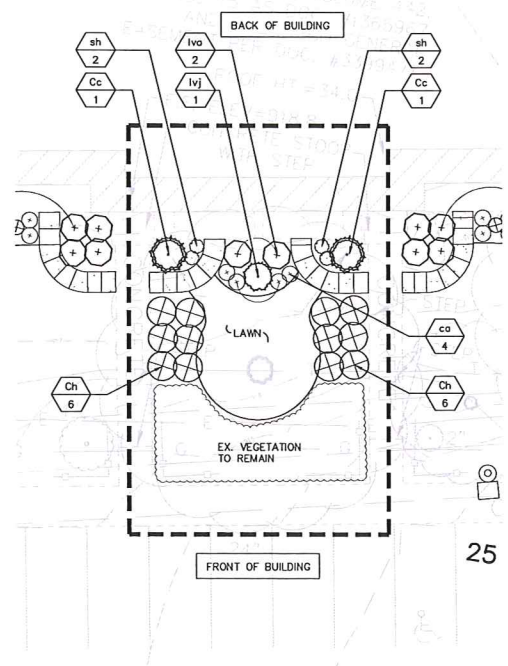

2B BUILDING FRONT YARDS - B
 C1.5C TYPICAL OF 5 SCALE: 1"=10'-0"

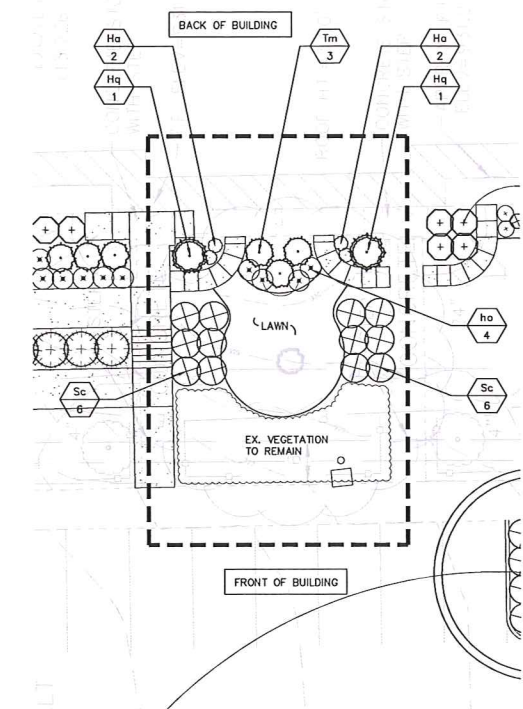

2C BUILDING FRONT YARDS - C
 C1.5C TYPICAL OF 4 SCALE: 1"=10'-0"

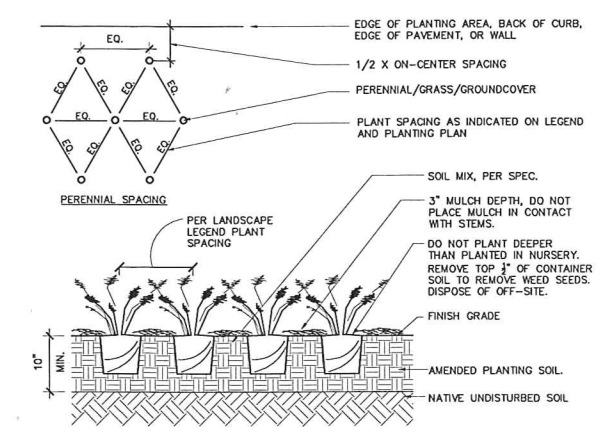

4 GROUNDCOVER / PERENNIAL PLANTING
 C1.5C SCALE: 1"=1'-0"

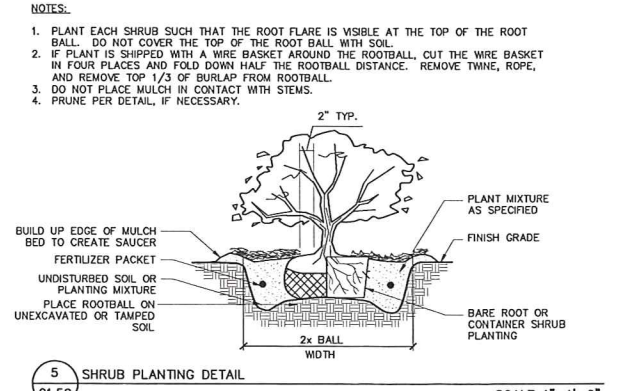

5 SHRUB PLANTING DETAIL
 C1.5C SCALE: 1"=1'-0"

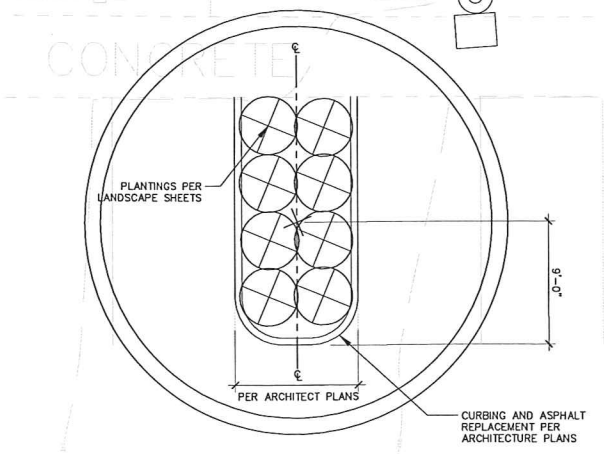

8 TREE ISLAND LAYOUT
 C1.5C TYPICAL SCALE: 1"=5'-0"

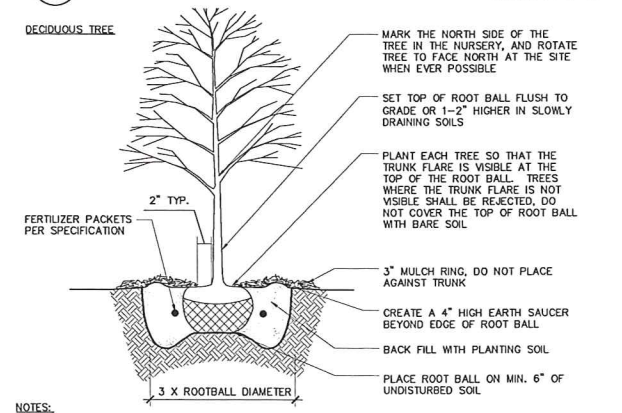

NOTES:

- DO NOT HEAVILY PRUNE THE TREE AT PLANTING, PRUNE ONLY CROSSOVER LIMBS, CO-DOMINANT LEADERS, AND BROKEN OR DEAD BRANCHES. SOME INTERIOR TWIGS AND LATERAL BRANCHES MAY BE PRUNED; HOWEVER, DO NOT REMOVE THE TERMINAL BUDS OF BRANCHES THAT EXTEND TO THE EDGE OF THE CROWN
- STAKE TREES ONLY UPON THE APPROVAL OF THE LANDSCAPE ARCHITECT
- WRAP TREE TRUNKS ONLY UPON THE APPROVAL OF THE LANDSCAPE ARCHITECT
- IF PLANT IS SHIPPED WITH A WIRE BASKET AROUND THE ROOT BALL, CUT THE WIRE BASKET IN FOUR PLACES AND FOLD DOWN 8" INTO THE PLANTING HOLE
- REMOVE ALL TWINE, ROPE/WIRE, AND BURLAP FROM TOP HALF OF ROOT BALL
- REFER TO SPECIFICATIONS FOR FURTHER INFORMATION

9 B&B TREE PLANTING DETAIL
 C1.5C SCALE: 1"=1'-0"

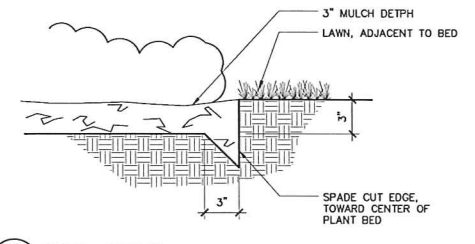

6 SHOVEL CUT EDGE
 C1.5C SCALE: 1"=1'-0"

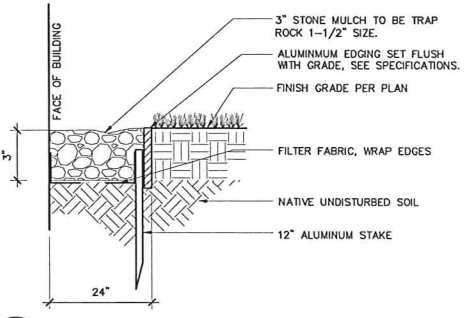

7 MAINTENANCE EDGE
 C1.5C SCALE: 1"=1'-0"

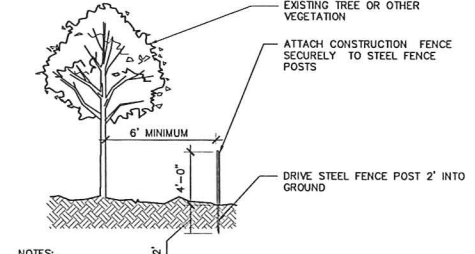

NOTES:

- PLACE FENCE POSTS 8' O.C. AND ATTACH CONSTRUCTION FENCE SECURELY TO STEEL FENCE POSTS
- NO ENTRY, NO STORAGE, AND NO TRENCHING IN TREE PROTECTION ZONE DURING ENTIRE SITE CONSTRUCTION.

10 TREE PROTECTION
 C1.5C SCALE: 1"=1'-0"

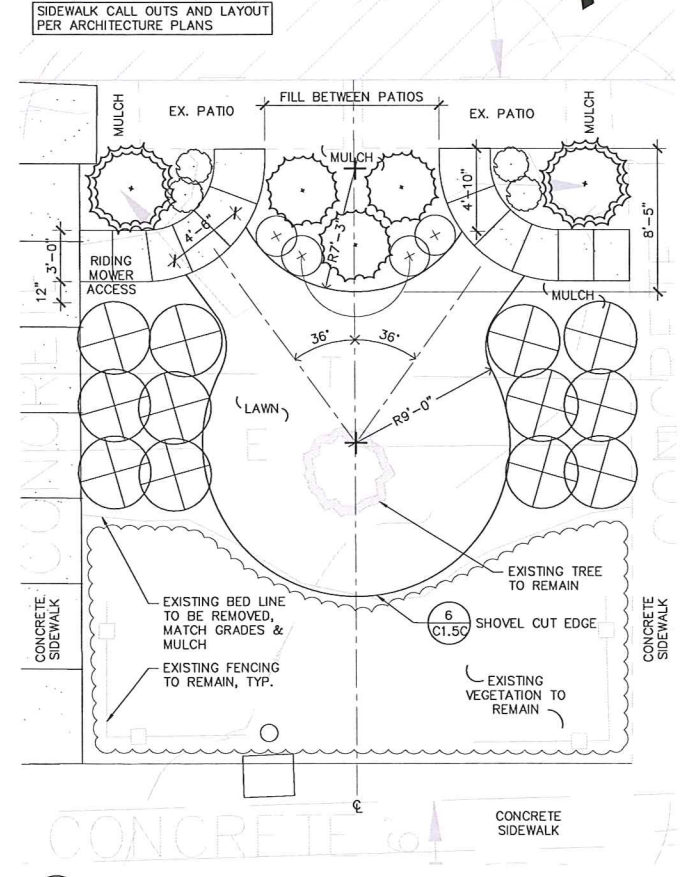

3 LAWN COURT ENLARGEMENT
 C1.5C TYPICAL SCALE: 1/4"=1'-0"

