

From: Jeremy Alsaker [mailto:dunkindanecounty@gmail.com]
Sent: Monday, January 16, 2012 9:41 AM
To: aaron.crandall@yahoo.com; Ellingson, Susan
Cc: Stouder, Heather
Subject: Park St developement

To: Monona Neighborhood association

Alder Sue Ellingson

I appreciate the time from you and the Neighborhood Association last Thursday. I have been working to obtain all of the requested information for review prior to Wednesday's meeting. I would appreciate if you would please forward this email to any parties that may be interested in the information. Also, I would offer the opportunity for anyone interested to contact me directly. My offer for anyone interested in looking at either of our existing restaurants also remains opened.

Please find attached the information you requested on the drive-thru system. I believe you will find what you were looking for in the attachments. There are also several pictures from one of our stores attached for your reference.

Dunkin Donuts Website:

<http://www.dunkindonuts.com/>

HME Website:

<http://www.hme.com/qsr/drive-thru-headsets-ION-IQ/>

Listen to the Ion IQ sound demonstration. This demonstrates the difference between the old analog systems and the new digital systems.

Number of Cars Projected in the Drive-Thru Each Day:

The volume of cars in the drive-thru predicted will most likely be higher during the Grand Opening and the few weeks following.

Drive-Thru System:

During my review with HME regarding the drive-thru system we would be using, I discovered a few details that would have been great to present at the neighborhood meeting. The information referenced was found in the "Drive-Thru Sound Pressure" attachment. The drive-thru system we use has digital sound. It comes preset to 72 decibels four feet from the speaker (the car window), and 60 decibels sixteen feet from the speaker.

It has AVC (Automatic Volume Control), which will help with many of the concerns regarding the volume of the drive-thru. The AVC automatically lowers the volume during times when there is less noise in the

surrounding area. For example, it would be 48 decibels 4 feet from the speaker and 36 decibels 16 feet from the speaker during quieter parts of the day. This system is the most advanced system that HME offers / manufacturers, and would be the one I would purchase. The numbers above assume NO noise in the surrounding area and NO sound barriers, such as a car or fence.

Fence Decibel Reduction:

Modifying the proposed fence was brought up at our last meeting and we are extending the fence from what was previously shown on the project. A fence reduces decibels by 6-15 decibels. To get the best results, you put the fence within 50 feet of the source of the sound. Shrubs and plants also help to absorb sound, and we would line the fence with plants, as well.

Decibel comparisons:

- * Decibels 15 feet from a busy road = 80
- * Normal conversation 3-5 ft. away = 60-70
- * Low volume TV or radio = 55
- * Running refrigerator = 50
- * Quiet library = 40

Email is the best way to contact me. Please feel free to email me any questions you have at dunkindanecounty@gmail.com and I will respond as soon as possible.

Thanks!

Jeremy



Wireless Drive-Thru Audio system

Installation Instructions

HM Electronics, Inc.
14110 Stowe Drive
Poway, CA 92064 USA

Phone: 1-800-848-4468
Fax: 858-552-0172

Table of Contents

1.	EQUIPMENT DESCRIPTION	1
1.1	Base Station Features	2
1.1.1	Front Panel	2
1.1.2	Rear and Side Panels	3
1.2	COMMUNICATOR [®] Features	4
1.2.1	Controls and Indicators	4
1.2.2	Correct Wearing of Headsets	5
1.2.3	Battery Removal and Replacement	6
1.3	Battery Charger	7
1.3.1	Battery Charger Setup for Use in the United States	7
1.3.2	Battery Charger Setup for Use Outside the United States	8
1.3.3	Battery Charging	8
2.	PREPARATION FOR INSTALLATION	9
2.1	Tools Required	9
2.2	Interference Prevention	9
2.2.1	Electrical Interference	9
2.2.2	Radio Frequency (RF) Interference	10
3.	EQUIPMENT INSTALLATION	11
3.1	Base Station Installation	11
3.1.1	Install Antennas on Base Station	13
3.1.2	Connect Base Station Power Supply	13
3.1.3	Register COMMUNICATOR [®] s to Base Station	14
3.1.4	Walk Test for Best Transmission/Reception	16
3.1.5	Mount Base Station on Wall	16
3.1.6	Install Remote Antenna Kit (if needed)	16
3.2	Cable Pulling	18
3.3	Outside Microphone and Speaker Installation and Cable Connections	18
3.3.1	Install DM4 Microphone	19
3.3.2	Install SP10 Speaker	20
3.4	Optional SP2000A Speaker/Microphone Installation	22
3.5	Optional External Vehicle Detector Installation	23
3.6	Optional HME Vehicle Detector Board (VDB) Installation	23
4.	BASE STATION SETTINGS	24
4.1	Settings Status	24
4.2	Basic Installer Setups	25
4.2.1	Lane Configuration	26
4.2.2	Split-B Audio	26
4.2.3	Auto-Hands-Free	26
4.2.4	Speaker Post	27
4.2.5	Clearsound	28
4.2.6	Diagnostics	28
4.3	Advanced Installer Setups	29
4.3.1	Phone	29
4.3.2	Network	30
4.3.3	Line In/Out Routing	31
4.3.4	Radio Options	31
4.3.5	Vehicle Tone	32
4.3.6	Save Installer Settings	32

HM Electronics, Inc. is not responsible for equipment malfunctions due to erroneous translation of its installation and / or operating publications from their original English versions.

4.3.7	Language Selection	32
4.3.8	Restore Defaults	33
4.4	User Settings	34
4.4.1	Vehicle Detection.....	34
4.4.2	Operator Mode	35
4.4.3	Message Center.....	36
4.4.4	Volume Adjustments.....	51
4.4.5	Register COMMUNICATOR®s.....	52
4.4.6	Service	52
4.4.7	Installer Setup	52
4.4.8	Store Settings	53
4.4.9	Diagnostics.....	60
4.4.10	Early Warning Setting.....	60
4.5	PC Navigation	61
4.5.1	PC Reports	62
5.	SYSTEM FUNCTIONAL CHECK.....	63
6.	ionIQ™ ROUTINE OPERATION	64
6.1	Changing COMMUNICATOR® Languages	64
6.2	Obtaining COMMUNICATOR® Status	64
6.3	Single-Lane Operation (one speaker post in one lane).....	65
6.4	Dual-Lane Operation (two lanes with one speaker post in each lane).....	66
6.5	Tandem Operation (two speaker posts in one lane).....	67
6.6	Internal Communication.....	68
6.7	Speed-Team Operation.....	69
6.8	Wired Backup System.....	69
6.9	Message Center Operation	69
7.	IN CASE OF PROBLEMS.....	70
8.	TO SET BASE STATION FOR SPANISH OR FRENCH LANGUAGE OPERATION	73
9.	EQUIPMENT SPECIFICATIONS	74
10.	BLOCK DIAGRAM	75
11.	BASE INTERFACE DESCRIPTION	76
11.1	Audio Circuit Board.....	76
11.2	Switcher Circuit Board.....	77
11.3	Vehicle Detector Circuit Board (Optional)	77
12.	WIRING DIAGRAMS.....	78

Figures and Diagrams

Figure 1. ionIQ TM standard equipment.....	1
Figure 2. Base station front panel features.....	2
Figure 3. Base station rear panel features.....	3
Figure 4. Control buttons and indicator lights.....	4
Figure 5. Correct wearing of the headset.....	5
Figure 6. Belt-pac battery-release latch.....	6
Figure 7. Headset battery-release latch.....	6
Figure 8. Batteries in charger.....	7
Figure 9. Battery charger power connection.....	7
Figure 10. Power supply wiring for battery charger used outside the United States.....	8
Figure 11. Typical drive-thru store layout.....	11
Figure 12. Typical tandem, Y-lane and dual drive-thru layouts.....	12
Figure 13. Antenna mounting.....	13
Figure 14. Power supply connection to base station.....	13
Figure 15. Open base station showing four screw holes.....	16
Figure 16. Remote antenna mounting on wall bracket.....	17
Figure 17. DM4 Microphone with attached windscreen.....	19
Figure 18. Placement of DM4 Microphone and foam cube in the foam enclosure.....	19
Figure 19. Microphone unit in typical speaker post installation.....	19
Figure 20. SP10 with gasket and cable connector plug.....	20
Figure 21. SP10 in speaker post, menu board or enclosure.....	20
Figure 22. Attach brackets to speaker.....	21
Figure 23. Installing the SP2000A.....	22
Figure 24. SP2000A cable connection.....	22
Figure 25. Typical tandem drive-thru layout.....	67
Figure 26. S2 switch on Switcher Board.....	69
Figure 27. Base station internal connectors and controls.....	72
Figure 28. Typical ionIQ TM Base Station block diagram.....	75
Wiring Diagrams.....	78
Figure 29. Full-Duplex Drive-Thru System with VDB but no Switcher Board (Lane 1 or Single Lane connections).....	79
Figure 30. Full-Duplex Drive-Thru System with VDB but no Switcher Board (Lane 2 connections).....	80
Figure 31. Full-Duplex Drive-Thru System with VDB, Switcher Board and IC300 (Lane 1 or Single Lane connections).....	81
Figure 32. Full-Duplex Drive-Thru System with VDB, Switcher Board and IC300 (Lane 2 connections).....	82
Figure 33. Full-Duplex Drive-Thru System with VDB, Switcher Board and Microphone (Lane 1 or Single Lane connections).....	83
Figure 34. Full-Duplex Drive-Thru System with VDB, Switcher Board and Microphone (Lane 2 connections).....	84
Figure 35. Half-Duplex Drive-Thru System with VDB but no Switcher Board (Lane 1 or Single Lane connections).....	85
Figure 36. Half-Duplex Drive-Thru System with VDB but no Switcher Board (Lane 2 connections).....	86
Figure 37. Half-Duplex Drive-Thru System with VDB and Switcher Board (Lane 1 or Single Lane connections).....	87
Figure 38. Half-Duplex Drive-Thru System with VDB and Switcher Board (Lane 2 connections).....	88
Figure 39. Optional Equipment.....	89

Illustrations in this publication are approximate representations of the actual equipment, and may not be exactly as the equipment appears.

FCC NOTICE

This device complies with Part 15 of the FCC rules. Operation is subject to the following two conditions: (1) This device may not cause harmful interference, and (2) This device must accept any interference received, including interference that may cause undesired operation.

NOTE: This equipment has been tested and found to comply with the limits for a Class A digital device, pursuant to Part 15 of the FCC rules. These limits are designed to provide reasonable protection against harmful interference when the equipment is operated in a commercial environment. This equipment generates, uses and can radiate radio frequency energy and, if not installed and used in accordance with the instruction manual, may cause harmful interference to radio communication. Operation of this equipment in a residential area is likely to cause harmful interference, in which case the user will be required to correct the interference at his own expense.

Changes or modifications not expressly approved by HM Electronics, Inc. could void the users authority to operate this equipment.

The antenna(s) used for the base transmitter must be installed to provide a separation distance of at least 7.87 inches (20 cm) from all persons, and must not be co-located or operating in conjunction with any other antenna or transmitter.

This device has been designed to operate with the antennas or antenna kits listed below, and having a maximum gain of 2dBi. Antennas/Kits not included in this list or having a gain greater than 2dBi are strictly prohibited for use with this device. The required antenna impedance is 50 ohms.

- 1. Antenna: NEARSON, S181TR-2450R, 2dBi*
- 2. Antenna Kit: HME, EC20 (P/N G28493-1), 0dBi*
- 3. Antenna Kit: HME, EC10 (P/N G27706-1)*

The term "IC:" before the certification/registration number only signifies that the Industry Canada technical specifications were met.

Hereby, HM Electronics, Inc. declares that the ion |IQ™ is in compliance with the essential requirements and other relevant provisions of R&TTE Directive 1999/5/EC.



This product operates in the 2400 to 2483.5 MHz frequency range. The use of this frequency range is not yet harmonized between all countries. Some countries may restrict the use of a portion of this band or impose other restriction relating to power level or use. You should contact your Spectrum authority to determine possible restrictions.

IMPORTANT!

Waste Electrical and Electronic Equipment (WEEE)

The European Union (EU) WEEE Directive (2002/96/EC) places an obligation on producers (manufacturers, distributors and/or retailers) to take-back electronic products at the end of their useful life. The WEEE Directive covers most HME products being sold into the EU as of August 13, 2005. Manufacturers, distributors and retailers are obliged to finance the costs of recovery from municipal collection points, reuse, and recycling of specified percentages per the WEEE requirements.

Instructions for Disposal of WEEE by Users in the European Union

The symbol shown below is on the product or on its packaging which indicates that this product was put on the market after August 13, 2005 and must not be disposed of with other waste. Instead, it is the user's responsibility to dispose of the user's waste equipment by handing it over to a designated collection point for the recycling of WEEE. The separate collection and recycling of waste equipment at the time of disposal will help to conserve natural resources and ensure that it is recycled in a manner that protects human health and the environment. For more information about where you can drop off your waste equipment for recycling, please contact your local authority, your household waste disposal service or the seller from whom you purchased the product.



1. EQUIPMENT DESCRIPTION

The ion|IQ™ is an audio system primarily for use at quick-service restaurants. The equipment shown below is standard with each ion|IQ™. Optional equipment can be ordered from your local dealer.

As you unpack the ion|IQ™, check the packing list for each item to verify receipt of all equipment and quantities listed.

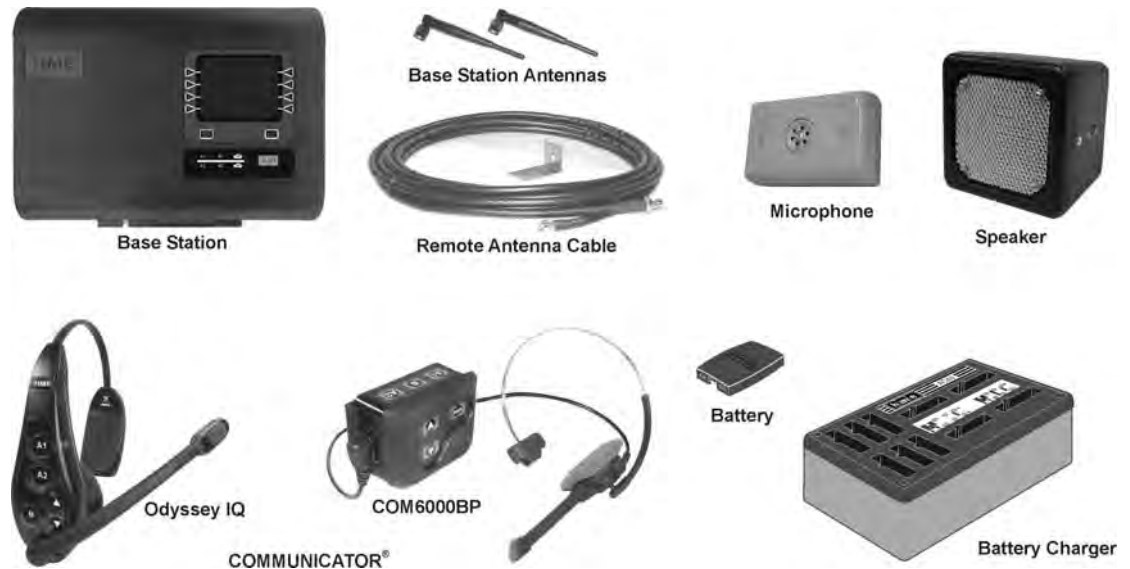

Figure 1. ion|IQ™ standard equipment

Optional Equipment

Equipment	Model Number	Equipment	Model Number
Belt-Pac Communicator	COM6000BP	Low-Profile Speaker	SP2500LP
Communicator Belt	None	Ceiling Speaker	MM100
Odyssey IQ Headset Communicator	HS6000	Microphone	DM4
Wireless Headset (listen only)	HS6000L	Mode Switch (dual lane)	MS10
Battery for Communicator	BAT41	Remote Speed Team Switch	SW2
Headset	HS12	Switcher Circuit Board	None
Headset Earmuff	None	Antenna Coverage Extension Kit	EC10
Headset Earpiece Cover (disposable)	None	Extended Coverage Antenna Kit	EC20
Headset Interface	HS16000	Remote Antenna Kit	
Telephone Interface	TI6000	(with 6 ft / 1.83 meter cable)	ANT20-6
Vehicle Detector Board	VDB102	Remote Antenna Kit	
Vehicle Detector Board (with relay)	VDB102R	(with 30 ft / 9.14 meter cable)	ANT20-30
Vehicle Detector Loop (underground)	VDL100		

IMPORTANT! Before doing anything else, set up the battery charger and charge the Communicator batteries according to the instructions in [section 1.3](#).

1.1 Base Station Features

The base station is the electronic heart of the ion|IQ™. It contains the circuitry through which all functions of the drive-thru audio system are channeled.

External base station features are shown in Figures 2 and 3. Internal controls and indicators are shown in Figure 27.

1.1.1 Front Panel

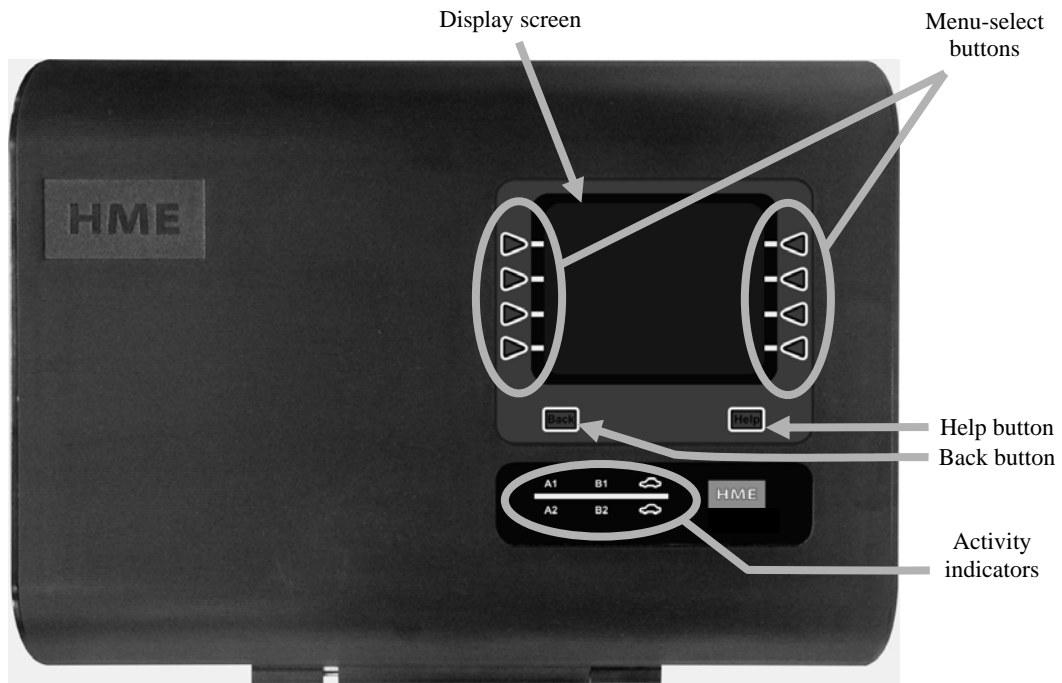

Figure 2. Base station front panel features

- The **display screen** is where all menu selections will be seen for installer setups and routine operation options. The **STATUS** display will be shown on the base station until you press any of the buttons to select another display. The STATUS display will go dark after a period of inactivity; pressing any button will light it up.
- The **menu-select buttons** are used to make selections from the menu on the display screen.
- The **Help button** can be pushed to obtain information needed in case of problems with the ion|IQ™.
- The **Back button** can be pushed to go back to the previous menu display.
- The **activity indicators** light up as follows:
 - Lane 1 activity (above the line)**
 - **A1** lights up when the A button is pushed on any Lane 1 COMMUNICATOR®.
 - **B1** lights up when the B button is pushed on any Lane 1 Communicator.
 - The **car above the line** lights up when a car is present at the Lane 1 menu board.
 - Lane 2 activity (below the line)**
 - **A2** lights up when the A button is pushed on any Lane 2 Communicator.
 - **B2** lights up when the B button is pushed on any Lane 2 Communicator.
 - The **car below the line** lights up when a car is present at the Lane 2 menu board.

1.1.2 Rear and Side Panels

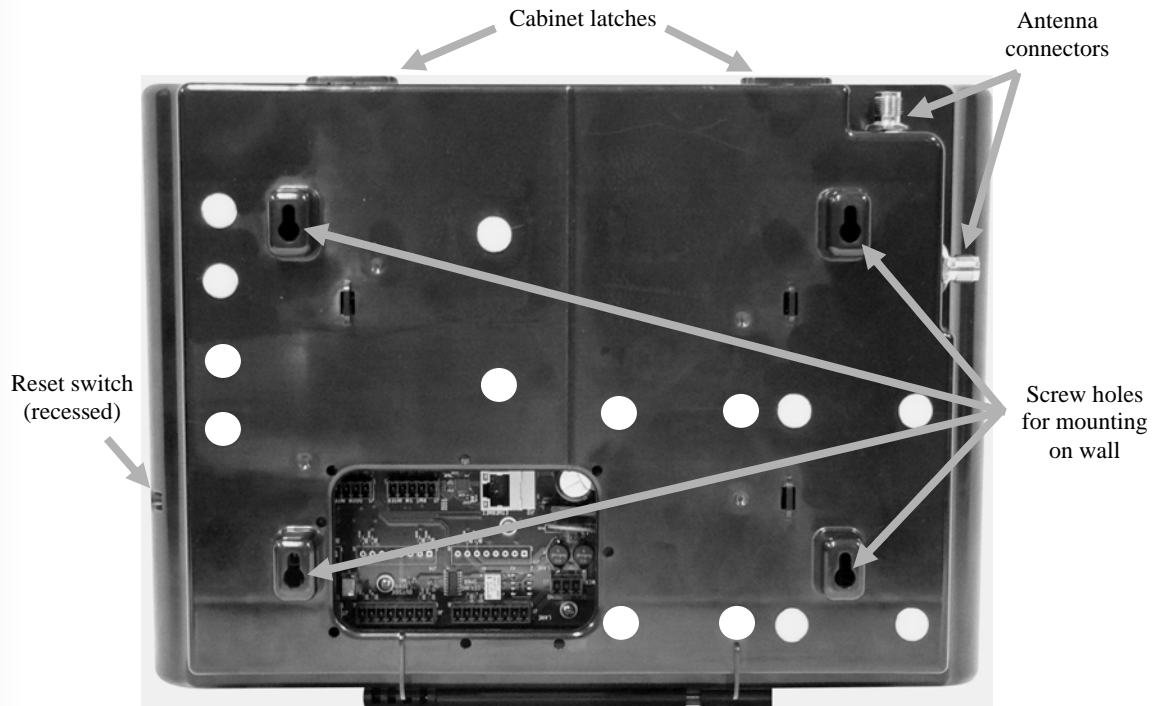

Figure 3. Base station rear panel features

- When both of the **cabinet latches**, on top of the cabinet are pressed down at the same time, the cabinet can be opened by pulling forward and down.
- The **antenna connectors** are for screw-mounting the enclosed antennas.
- The four **screwholes** are used to mount the base station on the wall.
- The **reset switch** is used to perform a soft restart of the base station. It is located in a small hole on the right side of the base station. To press the reset switch, push a small pointed object, such as an unfolded paper clip, into the hole.

1.2 COMMUNICATOR[®] Features

1.2.1 Controls and Indicators

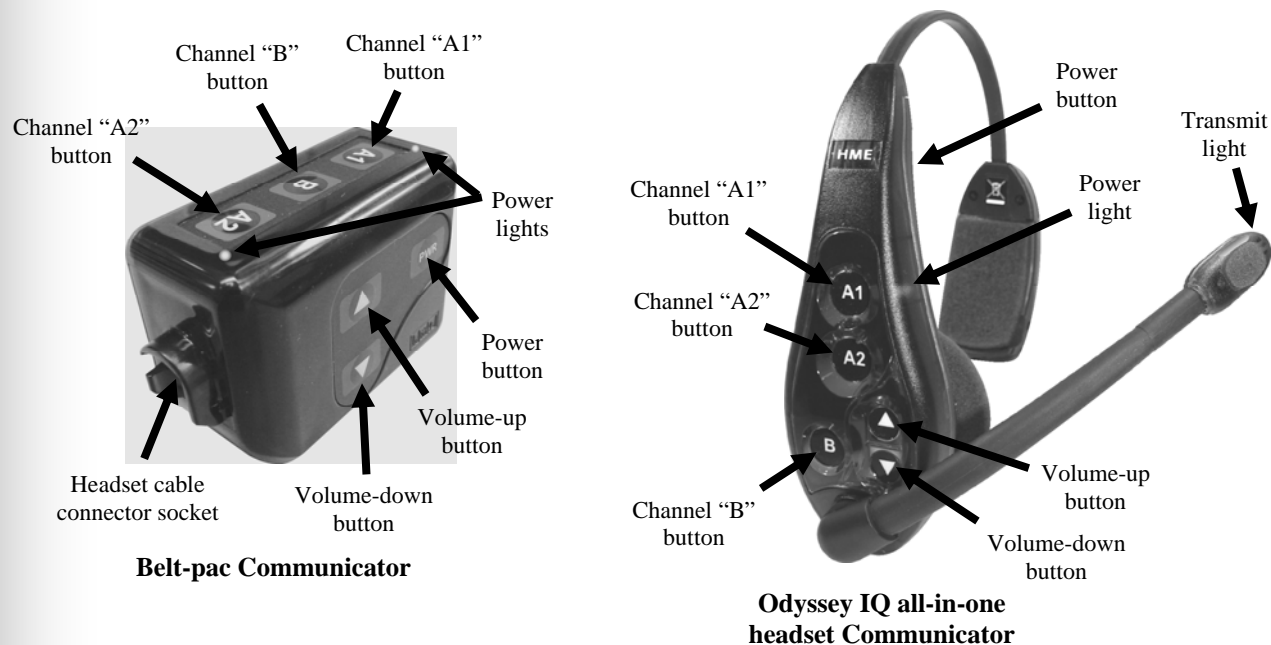

Figure 4. Control buttons and indicator lights

Note: The belt-pac control buttons have a snap action. They will activate when pressed firmly. Use your fingertips, not your fingernails, to press the buttons. The Odyssey IQ Headset control buttons have no snap action.

- **Power On** — Press and release the power button.
If using a **Belt-pac** — A voice message in the earpiece will say “belt-pac #, battery full/half/low” and the red power lights next to the A1 and A2 buttons on the belt-pac will blink. After a short time, the A2 light will go off and the A1 light will change to green. A voice message will then say “Lane 1.” The green light indicates the unit is ready to use. In dual-lane operations, a green light next to A1 indicates ready on Lane 1 and a green light next to A2 indicates ready on Lane 2.
If using an **Odyssey IQ** — A voice message in the earpiece will say “headset #, battery full/half/low” and both the power light and the transmit light will flash red. After a short time, the power light will change to steady green for Lane 1, and the transmit light will go off. A voice message in the earpiece will then say “Lane 1.”
- **Power Off** — Press and hold the power button for about two seconds. A voice message in the earpiece will say “belt-pac (or headset) off,” and the power light will go off.
- **Volume Up Adjustment** — Press and release the volume-up ▲ button. Each time you press the button you will hear a higher pitch beep in the earpiece as the volume increases. When you reach maximum volume, you will hear a high-pitched double beep. If you continue holding the volume-up ▲ button, the high-pitched beeps will keep repeating rapidly until you release the button.
- **Volume Down Adjustment** — Press and release the volume-down ▼ button. Each time you press the button you will hear a lower pitch beep in the earpiece as the volume decreases. When you reach minimum volume, you will hear a low-pitched double beep. If you continue holding the volume-down ▼ button, the low-pitched beeps will keep repeating rapidly until you release the button.

1.2.2 Correct Wearing of Headsets

- Wear the headset with the microphone on your right or left side next to your mouth.
- Adjust the headband and microphone boom as needed.
- If you are using a belt-pac with headset, clip the belt-pac to your belt or waistband on either your right or left side. Clip the clothing clips on the headset cable to the back of your shirt and collar.
- If you are using an Odyssey IQ headset, put the headset on your head with the headset band behind your neck.

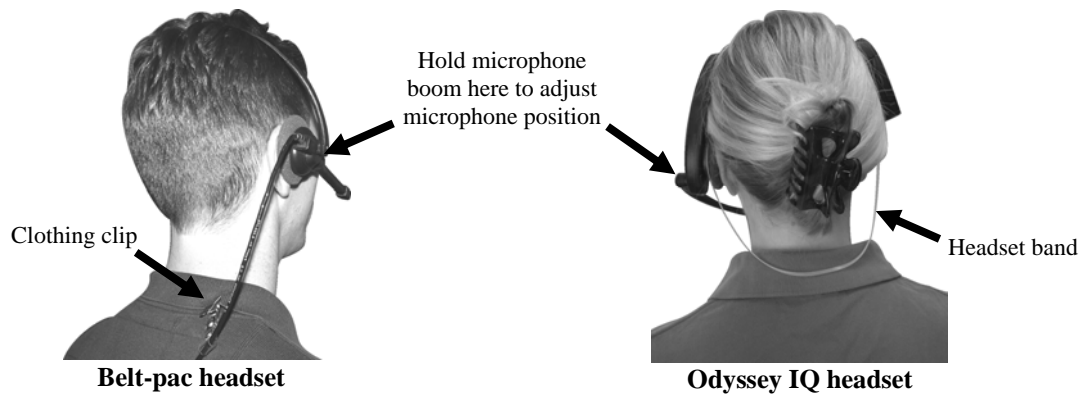

Figure 5. Correct wearing of the headset

1.2.3 Battery Removal and Replacement

Belt-pac Batteries —

To change batteries:

If a battery is weak when the belt-pac power is turned on, a voice in the headset will say “Battery low.” If a battery becomes weak during operation, a voice in the headset will say “Change battery.” When this happens, remove the belt-pac from its pouch and slide the battery-release latch in the direction of the arrow. Pull up on the end of the battery near the latch and lift it out of the belt-pac, or turn the belt-pac over and catch the battery in your hand.

To replace batteries:

Place the end of the battery with the metal contacts into the belt-pac, in the same position as the battery you removed. Press the top of the battery carefully down into the belt-pac until it snaps in place.



Figure 6. Belt-pac battery-release latch

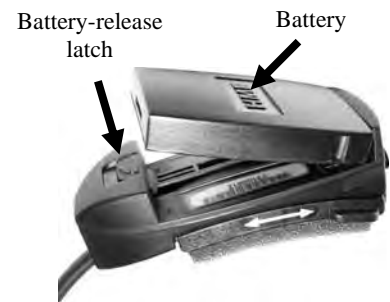

Figure 7. Headset battery-release latch

Odyssey IQ Headset Batteries —

To change batteries:

When a battery becomes weak, a voice in the Headset will say “Change battery.” When this happens, remove the battery from the Headset by carefully sliding the battery-release latch and lifting the battery out.

To replace batteries:

When replacing a battery in the Headset, place the end of the battery with the metal contacts into the battery holder on the Headset, in the same position as the battery you removed. Press the top of the battery carefully into the battery holder until it snaps in place under the battery-release latch.

Recharge batteries according to the following instructions.

1.3 Battery Charger

The battery charger has charging ports to charge up to four batteries at the same time. Charging time is about 2.5 hours. Six battery storage ports are provided to store fully charged batteries.

Battery Status Lights:

- A yellow light stays on steady next to each charging port while the port is empty.
- Insert a battery in one of the four charging ports until it clicks in place.
- If a yellow light is on steady next to a battery, it means CHARGE FAILED. Follow the diagnostic instructions on the side of the battery charger.
- If a yellow light is flashing next to a battery, it means CHARGE PENDING, the battery is too hot. Lower the room temperature or move the charger to a cooler area.
- A red CHARGING light will stay on next to a battery while it is charging.
- A green READY light will go on next to a battery when it is fully charged.
- Store fully charged batteries in the storage ports.

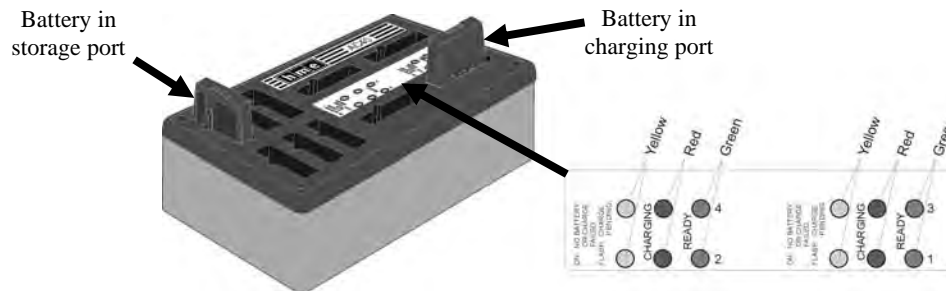

Figure 8. Batteries in charger

1.3.1 Battery Charger Setup for Use in the United States

- Connect the battery charger cable to the 24VDC power supply as shown in Figure 9.
- Plug the power supply into an AC electrical outlet. The red lights on the charger will come on and go off, then the yellow lights will come on and stay on.



Figure 9. Battery charger power connection

Note: If using a power supply other than that supplied by HME, it must provide 24 volts DC regulated to +/-5%, be capable of supplying a minimum of 50 watts of power and be "LPS" rated for safe operation of the unit. The power supply must meet all applicable local regulatory requirements.

1.3.2 Battery Charger Setup for Use Outside the United States

To use the battery charger outside the United States, in countries that require a 230 Volt AC adapter, a 24VDC power supply with an input AC voltage of 100-240VAC can be used. Depending on whether you have a **Type A** or **Type B** power supply (shown in Figure 10), prepare it according to the numbered instructions.

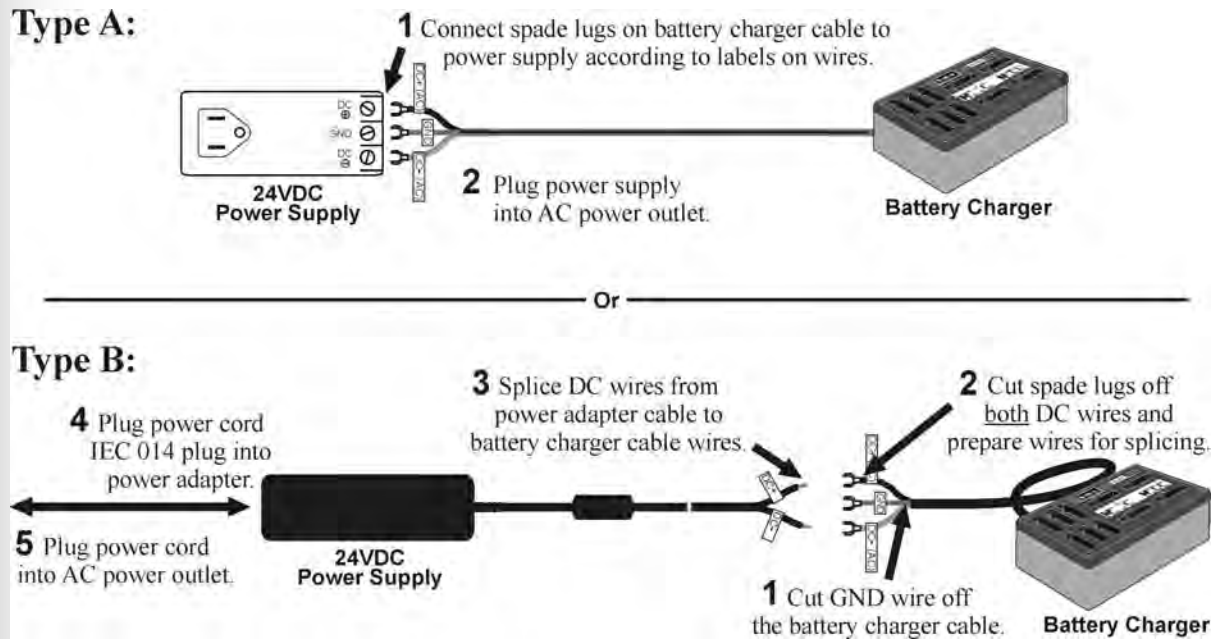

Figure 10. Power supply wiring for battery charger used outside the United States

1.3.3 Battery Charging

Insert up to four batteries into the charging ports to be charged while you are installing the other equipment. When they are fully charged, install them as shown in [section 1.2.3](#). Battery charging time is about 2 hours.

CAUTION: *Do not remove batteries from the charger until the green **READY** light is lit, or the charger will reset and the charge cycle will begin again.*

2. PREPARATION FOR INSTALLATION

- About 3 hours are required for ion|IQ™ installation.
- Before you begin, coordinate the time of installation with the store owner/manager to minimize disruption of business.
- Be certain electrical power is available.
- Be certain some type of compatible vehicle detector loop or other vehicle detector system has already been installed in the drive-thru lane(s).

2.1 Tools Required

- Phillips (cross-point) screwdriver, size #2
- standard (slotted) screwdriver, 1/8 inch (3.2 mm)
- power drill and drill-bit set
- fish tape, 100 feet (30 meters)
- wire cutter/stripper
- soldering iron
- rosin-core solder
- electrical tape

2.2 Interference Prevention

CAUTION: *Interference may occur if the audio system is not properly installed.*

The following types of interference could occur if precautions are not taken during installation. Read this section carefully before proceeding.

2.2.1 Electrical Interference

Electrical faults in appliances and other electrical equipment can cause interference such as static, hum, crackling, buzzing and zip sounds in the headset when the system is active. Interference caused by electrical faults in lighting systems might not be noticed immediately, since most lighting systems are controlled by a timer or light-sensing device.

Faulty Wiring or Components:

Faulty components or electrical wiring in menu boards or speaker posts can cause symptoms identical to those caused by AM interference. Remove power to the menu board or speaker post at the circuit breaker until the electrical system can be repaired.

Improper Earth Grounds:

Improper earth grounds in the building can cause random buzzing and zip sounds in the headset when operating in either channel A or B. Placing a surge protector between the base station AC adapter and the electrical outlet can eliminate the problem.

In the event of an electrical power outage — such as from a lightning storm or power generator failure, if you experience problems with your HME equipment after the electricity comes on again, unplug the equipment and wait 15 seconds, then plug it back in.

2.2.2 Radio Frequency (RF) Interference

Finding the cause of RF interference is difficult and time-consuming. The following precautions will help you avoid the most common RF interference problems.

- Find the best base station and antenna locations before mounting them.
- Solder all joints (including crimp joints) at the speaker location. This is very important in damp climates
- Be certain all connections are tight.
- Avoid leaving unshielded wire anywhere in the audio system.
- Ground the shield of the outgoing speaker cable. In severe cases of interference, grounding the shield at the speaker may help.

AM and FM interference may cause similar problems but require different corrective action. AM interference may increase or decrease at certain times of day, since AM transmitter power must be reduced in some areas between 5 and 7 PM.

Note the following symptoms carefully to determine the possible cause of interference. If you need help, call HME Technical Support at 1-800-848-4468.

AM Interference:

Static or hum may be heard in the headset when the system is active. The AM interference can enter the system through the cables connecting the outside speaker/microphone to the base station. To block the AM signal, first find out if there is an AM station in the area, and find out its operating frequency and transmitter output power. You can then modify the equipment with a network of inductors and capacitors that will trap the AM signal where it enters the system.

Static, hum and/or voice may be heard in the headset when the system is active or when transmitting in either channel A or B. The interference can enter the system at three different locations: the outside speaker cables, the COMMUNICATOR® receiver and the base station transmitter. The AM station frequency may completely suppress or overpower the audio system's transmitter signal, depending on the operating frequency, transmitter tower location and output power of the AM radio station. You may need to move the base station.

FM Interference:

FM interference may cause cracks, pops and other noises to be heard in the headset when the Communicator is transmitting on either channel A or B, or when the system is active.

3. EQUIPMENT INSTALLATION

These instructions are for installation of standard ion|IQ™ equipment and most commonly used optional equipment. Specific instructions may also be enclosed with optional equipment.

IMPORTANT! If you haven't already done so, before proceeding with the installation, plug the battery charger into an AC electrical outlet and charge all the batteries in it while the other equipment is being installed. Refer to [section 1.3](#).

3.1 Base Station Installation

Things to consider before and during base station installation

- The base station should be located where, if you stand with your back to the wall, you can see most of the work area where the COMMUNICATOR®s will be used.
- The number of walls between the base station and where the Communicators will be used should be minimized.
- Sheets of stainless steel on the walls may shield or reflect radio signals.
- Outside coverage may be needed for Speed Team operation.
- Large windows will allow the signal to pass through and can improve outside coverage.
- The antenna coverage area can be extended with the Remote Antenna Kit.
- If a system is being replaced, it may not be desirable to use the same mounting location for the base station as used before, but it may be required in some cases.
- If using a power source other than that supplied by HME, the power source must provide 24 volts DC regulated to +/-5%, be capable of supplying a minimum of 50 watts of power and be "LPS" rated for safe operation of the unit. The power source must meet all applicable local regulatory requirements.

A typical drive thru QSR building is set up as shown in Figure 11. The numbers in the following instructions refer to the location numbers in Figure 11. This drawing is similar to most store layouts. The base station is typically mounted at location #1. This is also where old equipment is usually found. The order taker is usually at location #2 in a high volume store. The order taker Communicator signal from location #2 must penetrate two walls to reach the base at location #1. Communicator signals from the kitchen must only penetrate one wall to reach the base at location #1. If there are large pieces of equipment in the kitchen or speed team operation is needed outside at location #6, location #1 may be a poor choice for mounting the base. For speed team operations, the signal would have to penetrate three walls and get by the kitchen equipment to reach the base at location #1. Coverage in the store around location #7 and outside at location #6 may be poor. Don't forget to check for a basement. Communicator signals from basements may not reach the base at location #1.

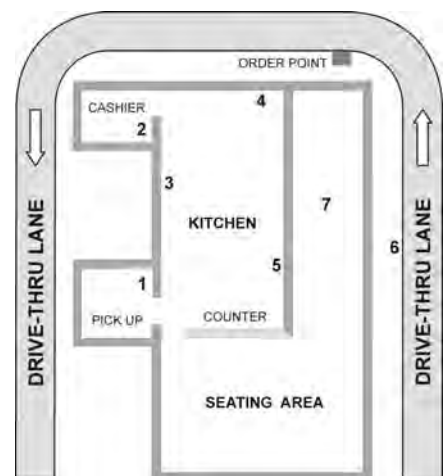

Figure 11. Typical drive-thru store layout

If outside coverage is not needed, mounting the base at locations #3, #4 or #5 is best. COMMUNICATOR® signals from most work areas would thereby require no wall penetration. Other work and seating areas may require signals to penetrate one wall. In this case, the remote antenna kit can be used. The antenna may not need to be mounted far from the base station unless a large piece of equipment causes a dead spot. The ion |IQ™ base uses two antennas to avoid multi-path dropouts. Both antennas transmit and receive signals. The antenna coverage area can be improved by mounting one antenna away from the base. The base will select the antenna that gives the best signal to a particular Communicator location.

If outside coverage is required for speed team coverage, mount the base as close as possible to the wall that faces the desired coverage area. In this case, mounting the base at location #5 to cover location #6 will minimize wall penetrations. Stores with a large window near the base will have better outside coverage if the base is facing the windows. If there are large windows along the wall next to location #6 outside coverage will be enhanced. Also consider in-store coverage. If the base is located in the best location for inside and outside coverage, but the coverage outside is still spotty then the antenna extension cable needs to be run outside the store. In this case, hanging the antenna under an eave next to the desired area will cover that side of the store very well. Another approach is to go up through the roof and have the antenna overlook the desired side area. This approach overcomes obstacles, like walls, that may shadow the signal when the antenna is at a lower height.

Discuss the location of the base station with the store owner or manager. It should be mounted less than 10 feet (3 meters) from an available electrical outlet, and away from grease and large metal objects. Also, it should be mounted near eye level, so the display screen will be easily visible and the control buttons will be accessible. The base transmitter antenna(s) must be installed where they will be at least 7.87 inches (20 cm) from all persons, and will not be near any other antenna or transmitter. The remote antenna kit should be used to extend the coverage area if needed. [See section 3.1.6.](#)

Tandem, Y-Lane or Dual Drive-Thru

For tandem, Y-lane or dual drive-thrus, a vehicle detector and an outside speaker and microphone will be installed for each order point, and cables pulled as described in [sections 3.2 and 3.3.](#)

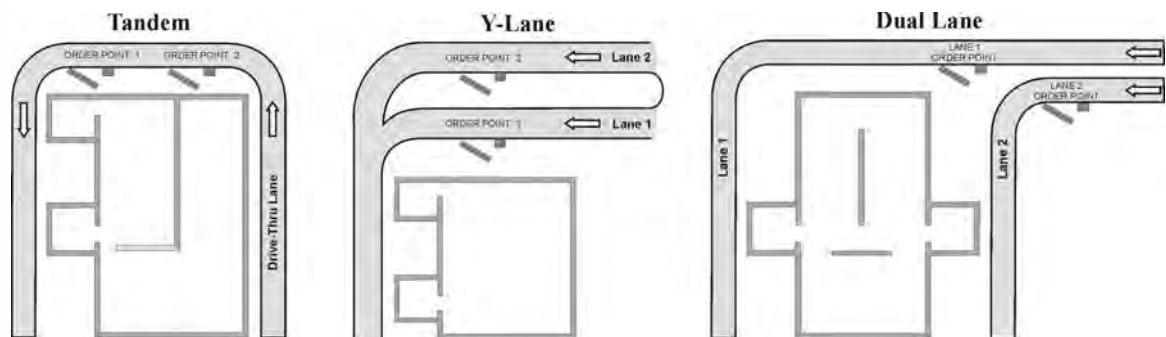

Figure 12. Typical tandem, Y-lane and dual drive-thru layouts

3.1.1 Install Antennas on Base Station

Locate the two enclosed antennas, and install them by screwing them onto the base station antenna connectors, as shown in Figure 13.

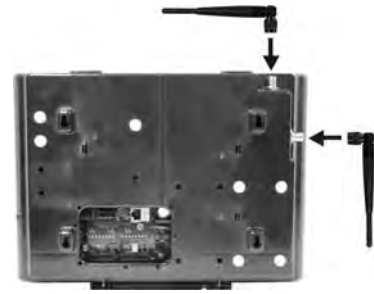

Figure 13. Antenna mounting

3.1.2 Connect Base Station Power Supply

You may have Type A or Type B power supply, as illustrated in Figure 14. Connect the power supply to the base station and an AC electrical outlet according to the numbered instructions for your type power supply, as shown in Figure 14. If necessary, refer also to the [wiring diagrams](#) in Figures 29-39.

Note: If using a power source other than that supplied by HME, it must provide 24 volts DC regulated to +/-5%, be capable of supplying a minimum of 50 watts of power and be "LPS" rated for safe operation of the unit. The power source must meet all applicable local regulatory requirements.

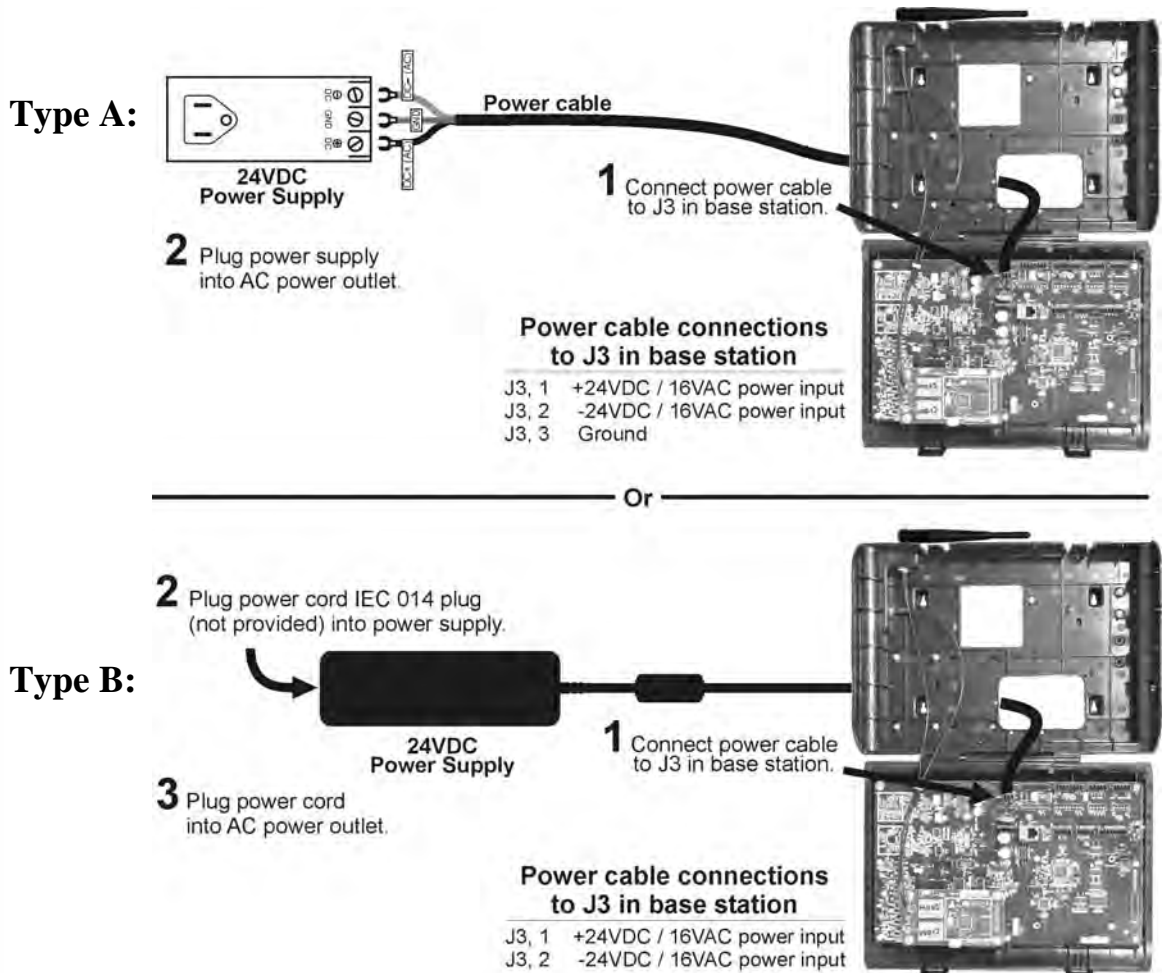

Figure 14. Power supply connection to base station

3.1.3 Register COMMUNICATOR®s to Base Station

IMPORTANT! **Before you permanently mount the base station on the wall,** you must register the Communicators to the base station, so they can be used in a walk test to determine where the base station should be mounted for the best reception and transmission to/from all the areas where they will be used.

After each Communicator has been “registered” to a base station, the base station will recognize it when its power is on, and will be able to tell the difference between it and other electronic equipment operating on similar frequencies.

Up to 15 Communicators can be registered to a base station. If a Communicator is replaced, you must register the new one before you use it. When a Communicator is replaced, the old one remains in memory. If the maximum number of 15 (in memory) is exceeded, you must clear some/all of the current registrations so that fewer than 15 Communicators are registered before you can register a new one.

Register each COMMUNICATOR® as follows:

Note: Communicators must be within 6 feet (1.83 meters) of the base station while being registered.

- Be certain all Communicators to be registered are turned off and the base station is plugged in and its power is on. Other Communicators can be on or off.
- On the **STATUS** display, press the **Menu** button.

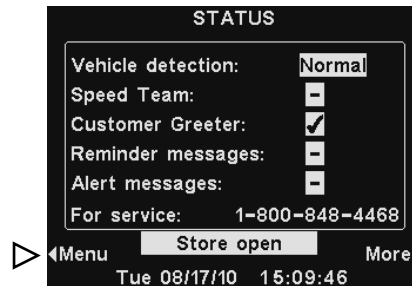

- On the **MAIN MENU** display, press the **Register headsets** button.

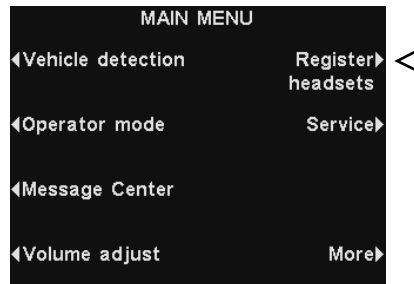

- On the **HEADSET REGISTRATION** display, press the **Register headsets** button.

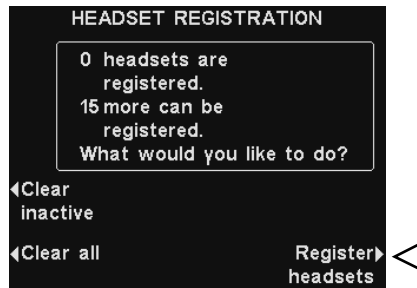

If you press the **Clear inactive** button, you will unregister any headsets that are not turned on.

If you press the **Clear all** button, you will unregister all headsets that are registered to the base station, and the base station will automatically reset.

- On the **TO REGISTER HEADSETS** display, follow the instructions in the box.



- If you are registering only one headset, press the **Register single** button.
- If you are registering more than one headset, press the **Register multi** (multiple) button and continue registering the remaining headsets.

When each registration is successfully completed:

- The ID number assigned to this Communicator will be shown. ID numbers are assigned sequentially as 0 thru 9, A, B, C, D and E.
- The power light on the Communicator will remain on steady green.



- When you have finished registering headsets, press the **Back** button to exit the registration mode. You can repeat pressing the **Back** button until you return to the **MAIN MENU** or **STATUS** display.

If you have any problems registering the headsets:

In the USA, call HME Technical Support at 1-800-848-4468.

Outside the USA, call your local HME representative for assistance.

3.1.4 Walk Test for Best Transmission/Reception

Before permanently mounting the base station, do a walk test with the base station at various locations until the best possible transmission/reception is found. To check transmission/reception, have two people walk around the area where the COMMUNICATOR®s will be used, pressing the B button to communicate with each other, walking past the menu board to test reception when using speed-team operation.

Note: If you need to extend the antenna coverage area, install a Remote Antenna Kit as described in section 3.1.6, but do not permanently mount the antenna. Repeat the walk test, while moving the antenna around the area to determine where the antenna improves transmission/reception most.

3.1.5 Mount Base Station on Wall

When you have found the best location for transmission and reception, unplug the power adapter and mount the base station at the desired location as follows.

- Hold the base station against the wall, with its door open, and mark the wall through the four screw holes on the back of the cabinet, shown in Figure 15.
- Set the base station down and drill four $\frac{3}{16}$ inch (4.76mm) holes in the wall at the marked spots.
- Insert the enclosed #6 screw anchors into the holes.
- Screw the four enclosed screws into the anchors, leaving the screw heads $\frac{1}{8}$ inch (3.2 mm) away from the wall.
- Mount the base station on the wall by placing the four screw holes in the back of the base station over the four screws, sliding the base station downward and then tightening the screws to secure the base station in place.
- Install optional switcher boards and vehicle detector boards after mounting base station on wall.



Figure 15. Open base station showing four screw holes

3.1.6 Install Remote Antenna Kit (if needed)

The remote antenna kit allows one of the antennas to be mounted up to 30 feet (9.14 meters) from the base station for improved coverage. With the extension cable and mounting bracket, an antenna can be mounted inside a window or outside to extend coverage for speed team operation. Install the remote antenna kit as follows.

- Lay out the enclosed 30 foot (9.14 meter) antenna cable, with its female connector near the base station and its male connector at the proposed area where the antenna will be mounted. Bend and align the cable to the desired position.
- Remove electrical power from the base station.
- Remove (unscrew) the antenna from the top of the base station.
- Screw the female antenna cable connector onto the base station antenna connector where the antenna was removed.

Note: To minimize stress on the connector, bend the cable to line it up with the base station antenna connector before connecting it.

- Screw the antenna onto the male connector at the other end of the antenna cable.

- Hold the enclosed antenna mounting bracket against the wall at the desired mounting location and mark the wall through the two screw holes in the bracket. It may be necessary to mount the antenna high enough to avoid a safety hazard or possible damage to the antenna.
- Remove the bracket from the wall and drill two $\frac{3}{16}$ inch (4.76mm) holes in the wall at the marked spots.
- Insert the enclosed screw anchors into the holes.
- Place the enclosed screws through the holes in the bracket and screw them into the two screw anchors to secure the bracket to the wall.
- Remove the antenna from the antenna cable. **DO NOT** remove the antenna cable from the base station.
- Unscrew the hexagonal nut from the antenna cable connector.
- Insert the antenna cable connector through the hole in the mounting bracket as shown in Figure 16, and screw the hexagonal nut onto the connector to secure it in place on the bracket.

Note: To minimize stress on the bracket, bend the cable to line it up with the bracket before connecting it.

- Replace the antenna on the cable connector mounted on the wall.

Note: The best transmission/reception may be achieved with the antenna perpendicular to the wall. However, if it is a safety hazard or is likely to be bumped and damaged in that position, it may be necessary for the antenna to be parallel to the wall.

- Return electrical power to the base station and resume normal operation.

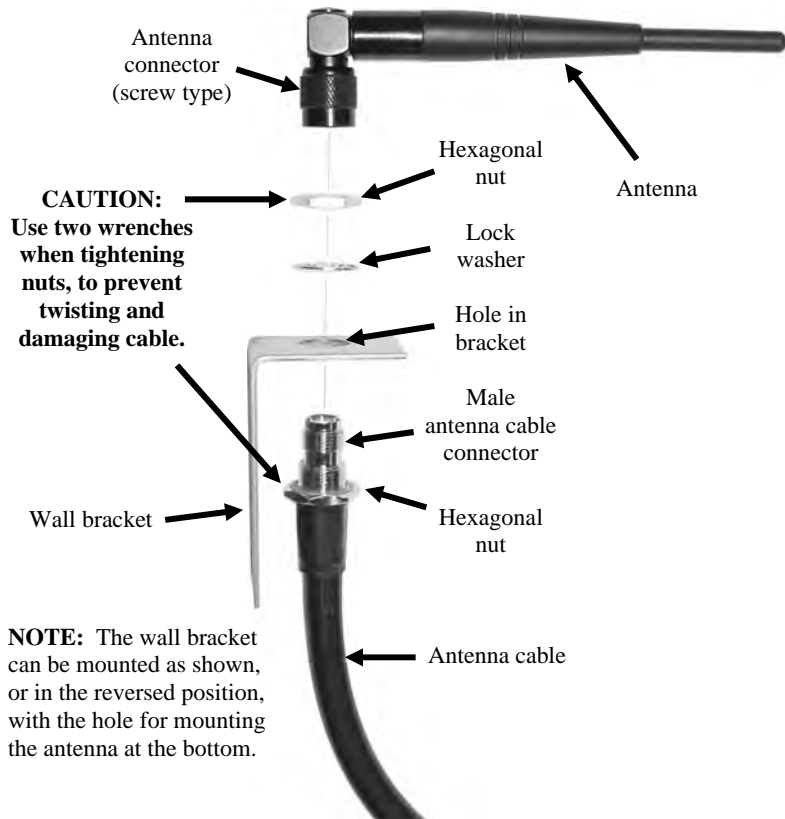

Figure 16. Remote antenna mounting on wall bracket

3.2 Cable Pulling

CAUTION: *If you do not use the HME audio cable, be sure the speaker/microphone wires you use are a twisted pair. For full-duplex installations, the speakers and microphones must use separate cables or audio feedback will occur. Never run high-voltage cables in the same conduit with audio or loop cables.*

The recommended HME audio cable has four color-coded, insulated wires and a bare shield (drain) wire. It can be used to connect any component to the base station. Pull the cables (two for full-duplex, one for half-duplex) through the conduit from the speaker post or menu board into the building as follows.

For dual drive-thru installations, repeat the following steps to route **shielded** cable from inside the building to the speaker post or menu board in each lane.

For tandem drive-thru installations, repeat the following steps to route **shielded** cable from inside the building to the speaker post or menu board at each order point.

- Run fish tape from inside the building, through the conduit to the speaker post or menu board.
- Go outside. If you are pulling more than one cable, **mark the cables and spools for identification**. Fasten each cable to the fish tape where it comes out of the conduit, and go back inside the building.
- Pull the fish tape and cable through the conduit into the building. Disconnect the cable from the fish tape and pull enough of it in to reach the base station.
- Go outside again and route the cable from the outside conduit to the speaker and microphone units in the speaker post or menu board.
- Cut the cable, leaving about 3 feet (915 mm) of slack. If more than one cable have been pulled, **mark the ends of the cables again for identification**.
- Remove about 2 inches (50 mm) of the outer insulation from the end of each cable. Strip about ½ inch (12 mm) of insulation from each of the four wires in the cable.
- Route all the cables together to the base station, through walls and over ceiling panels if possible. Cut off any slack cable so no coils of excess cable are left in the ceiling or elsewhere.

3.3 Outside Microphone and Speaker Installation and Cable Connections

This section describes standard, full-duplex installations, using a DM4 Microphone and SP10 Speaker. Installation requirements may vary. In dual-lane or tandem systems, speakers and microphones must be installed for each lane or order point. Refer to the [wiring diagrams](#) in Figures 29 through 30.

Note: For half-duplex installations only, the SP2000A Speaker/Microphone Unit can be used. See [Section 3.4](#) for installation of the SP2000A.

In full-duplex systems the standard microphone and speaker provide the best performance. However, in some cases the DM1 Microphone may be used. For DM1 installation, refer to the instructions enclosed with the unit. For either the DM1 or DM4, refer to the appropriate [wiring diagram](#) in Figures 29 through 30.

Mount the microphone first, against the speaker grill in the speaker post or menu board. Position it where the customer will speak directly into it. The speaker can then be installed anywhere around the microphone, as long as they are at least 2 feet (610 mm) apart, center-to-center, to avoid audio feedback.

3.3.1 Install DM4 Microphone

Typical DM4 Microphone installation involves placement of the microphone in its molded foam enclosure and mounting it inside the upper compartment of the speaker post, connecting it to the microphone/speaker cable wires from the drive-thru audio system, and filling the empty space behind the unit with acoustic foam (not provided). If the DM4 is mounted in a small area, its molded foam enclosure may need to be compressed in order to close the compartment. Follow these instructions to install the DM4 in a typical speaker post. Installation in the microphone compartment of a menu board is similar to installation in a speaker post.



Figure 17. DM4 Microphone with attached windscreen

- Open the speaker post and remove any existing equipment, foam or debris. If there is an existing microphone, remove it and disconnect the microphone cable from it.
- Remove the small foam rectangular portion of the provided foam microphone enclosure, resulting in the two pieces of foam shown in Figure 18, A.
- Insert the DM4 Microphone cable through the hole in the foam enclosure, and place the microphone into the hole as shown in Figure 18, A, with its attached windscreen flush with the front of the foam enclosure.
- Insert the foam back into the hole in the foam enclosure, to fit snugly against the back of the microphone, as shown in Figure 18, A and B.

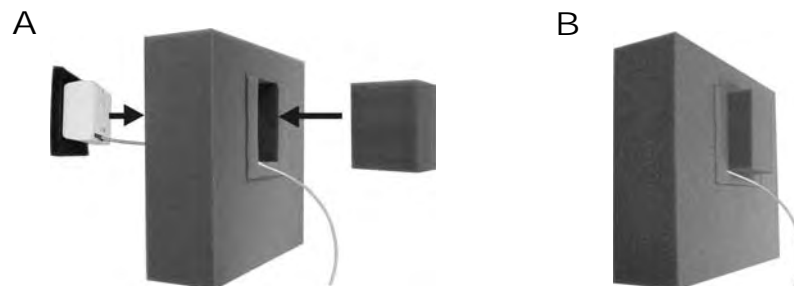

Figure 18. Placement of DM4 Microphone and foam cube in the foam enclosure

- Using a serrated knife, trim the foam enclosure so it is $\frac{1}{4}$ to $\frac{1}{2}$ inch larger than the upper speaker post compartment, vertically and horizontally, for a compressed fit. Keep the foam pieces to fill the compartment, if needed.
- Place the microphone, in its foam enclosure, into the compartment, so the front of the microphone windscreen is **flush against the metal**, centered on the grill, as shown in Figure 19.
- Splice the audio system's microphone cable wires (new or existing) to the wires of the cable extending from the back of the DM4, according to the audio system wiring diagram. Solder the connection, then cover the splice with shrink tubing or crimp caps.
- Pack acoustic foam (not provided) in the empty space behind the DM4 Microphone and its foam enclosure, filling the space.

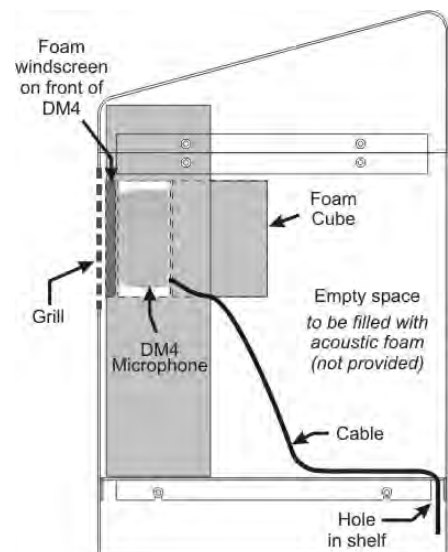

Figure 19. Microphone unit in typical speaker post installation

3.3.2 Install SP10 Speaker

- Strip approximately 1 inch (25.4 mm) of insulation from the end of the speaker cable, and $\frac{1}{4}$ inch (6.35 mm) of insulation from each of the two cable wires, but do not tin the wires. Connect the speaker cable wires to the connector plug as shown in Figure 20.
- Insert the connector plug into the connector on the speaker as shown in Figure 20.

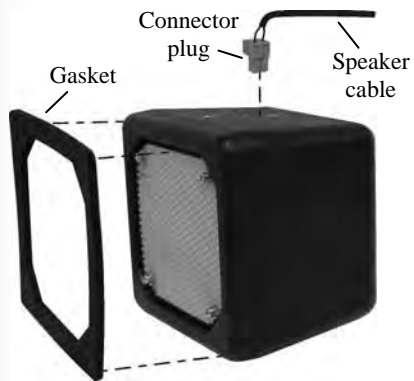

Figure 20. SP10 with gasket and cable connector plug

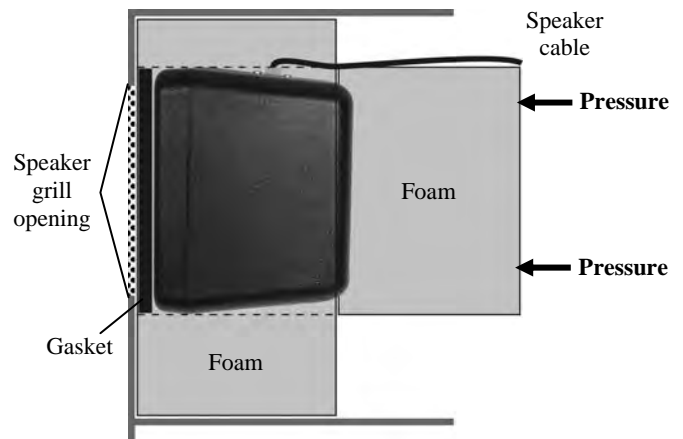

Figure 21. SP10 in speaker post, menu board or enclosure

If not using the optional mounting brackets:

- Peel the paper off the self-adhesive gasket, and press the adhesive side of the gasket against the front of the speaker in the position shown in Figure 20.
- Position the speaker inside the speaker post or menu board, with the gasket centered against the inside of the speaker grill as shown in Figure 21. The cable connector can be on top or on either side. Align the opening in the gasket with the grill opening.
- Remove both inserts from the molded foam enclosure and place the foam enclosure around the speaker. Trim foam with serrated knife if necessary. Place removed foam inserts behind speaker to provide pressure to speaker, to ensure a good gasket seal against the speaker grill opening.

If using the optional mounting brackets:

- Attach the brackets to the screw inserts on the sides of the speaker unit with the two Phillips (crosspoint) screws provided as shown in Figure 22.



Figure 22. Attach brackets to speaker

- Hold the front of the speaker centered against the speaker grill of the menu board or speaker post. Mark the menu board or speaker post through the open holes in each of the two mounting brackets on the speaker, and set the speaker aside. Drill holes at the two marked spots, approximately the same size as the holes in the speaker mounting brackets.
- Peel the paper off the self-adhesive gasket, and press the adhesive side of the gasket against the front of the speaker in the position shown in Figure 20.
- Hold the speaker inside the speaker post or menu board, with the gasket against the speaker grill and the holes in the mounting brackets over the two drilled holes.
- From outside the speaker post or menu board, place the two washers on the enclosed security screws, and insert the screws through the two drilled holes. Inside the speaker post or menu board, place the locking nuts on the security screws. Tighten the nuts on the screws only enough to provide a good seal between the gasket and the enclosure.
- Place foam around the sides and back of the speaker as shown in Figure 21.

3.4 Optional SP2000A Speaker/Microphone Installation

The installation described below is for typical mounting of the SP2000A directly against the inside of the speaker grill. If it needs to be mounted at an angle, or at a distance from the speaker grill, its base can be bolted to a horizontal surface. Installation of this speaker is not recommended, except for half duplex systems.

Installation:

- Drill four $\frac{1}{8}$ inch (3.2 mm) pilot holes at the spots shown in Figure 23 A, in the flange of the SP2000A.
- Find the enclosed SP2000A mounting template. Hold the template centered against the outside of the speaker grill on the speaker post or menu board. With a pencil or other sharp object, mark the speaker grill through the four drill-hole targets on the template. Drill a $\frac{3}{16}$ inch (4.8 mm) hole at each of the marked spots.
- Hold the SP2000A flush against the inside of the speaker grill, with the four pilot holes on its flange directly over the four holes drilled through the grill speaker. From the outside of the speaker grill, drill the four enclosed self-tapping screws through the drilled holes in the speaker grill and through the SP2000A flange at each pilot hole, as shown in Figure 23 B.

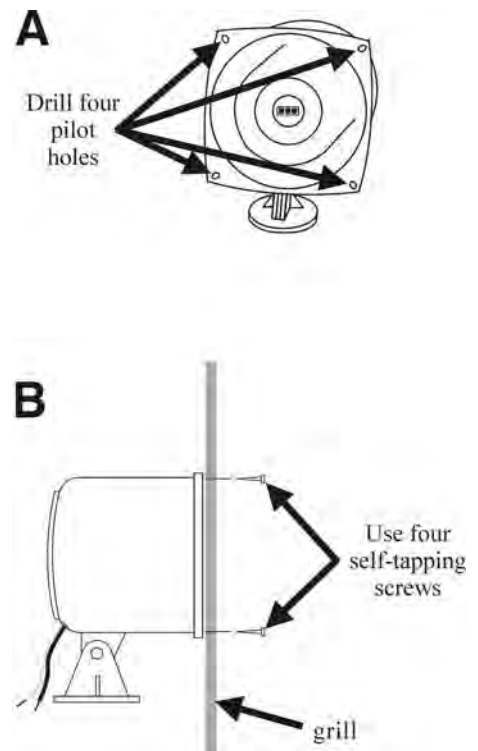

Figure 23. Installing the SP2000A

Cable Connections:

CAUTION: Never run high-voltage cables in the same conduit with audio or loop cables.

- Connect the red wire from the appropriate cable to the white SP2000A wire, and the black cable wire to the black SP2000A wire as shown in Figure 24. Do not connect the drain wire.
- Solder the connection and cover it with electrical tape. Solder all splices.

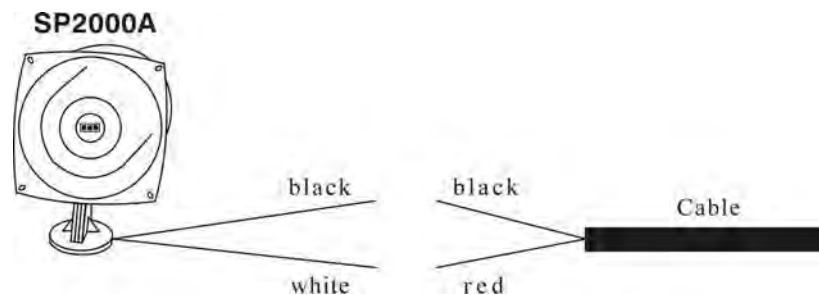

Figure 24. SP2000A cable connection

3.5 Optional External Vehicle Detector Installation

- If an external type vehicle detector will be used, install it according to its own installation instructions. Connect it to the base station according to the appropriate [wiring diagram](#) in Figures 29 through 39. Note that the connections are different for internal and external vehicle detectors.
- For an external vehicle detector in Lane 1, route a cable from the detector's output to the J6 connector on the audio board in the ion|IQ™ base station. For an external vehicle detector in Lane 2, route a cable from the detector's output to the J14 connector on the audio board.
- Remove 4 inches (100 mm) of outer insulation from the end of the cable at the base station, and strip about ¼ inch (6 mm) of insulation from each of the color coded wires coming from the cables.
- Connect the color-coded wires to connector J6 and/or J14, pins 3 and 5 for negative vehicle detection according to the [wiring diagrams](#) in Figures 29 through 39. Be sure the wires are fully inserted into each connector plug to prevent shorting the wires.

3.6 Optional HME Vehicle Detector Board (VDB) Installation

To install an HME VDB in the base station, follow the instructions below.

Note: In tandem systems, two VDBs will be installed in the base station, one at the “VDB LANE 1” position for Order Point #1, and one at the “VDB LANE 2” position for Order Point #2.

- Open the base station by pushing down on the latches on top of the cabinet and VERY CAREFULLY guiding the top of the cover toward you and downward.
- Position the three holes in the VDB over the three plastic standoffs at the upper right side, inside the base station, in the position shown on the respective [wiring diagram](#) in Figures 29 through 39. Press on the VDB until the tips of the three standoffs snap through the holes in the board.

If there is a switcher board, connect the cable assembly enclosed with the VDB to the P1 connector on the vehicle detector board, and the other end to the J6 connector on the respective LANE 1 or LANE 2 switcher board as shown on the [wiring diagrams](#) in Figures 29 through 39.

If there is no switcher board, connect the cable assembly to the P1 connector on the vehicle detector board, and the other end to the J10 connector (or J20 for Lane 2) on the audio circuit board as shown in the [wiring diagrams](#) in Figures 29 through 39.

- Route a cable from the underground loop(s) to the TB1 terminal block on the Vehicle Detector Board(s).
- Close the cover on the base station, and lock it by pushing until it latches.

4. BASE STATION SETTINGS

4.1 Settings Status

The **STATUS** display shows current, basic system setup information. It also lists the HME Technical Support toll-free phone number to call for service. The date and time are shown at the bottom of the screen.

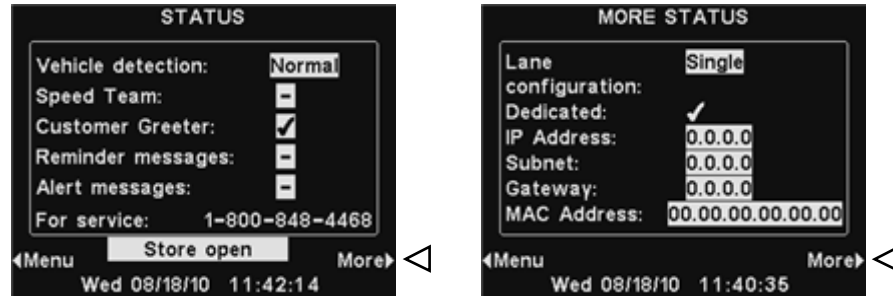

To view additional system status, press the **More** button at the bottom-right of the **STATUS** display. The information on the **MORE STATUS** displays will be needed if you require technical support.

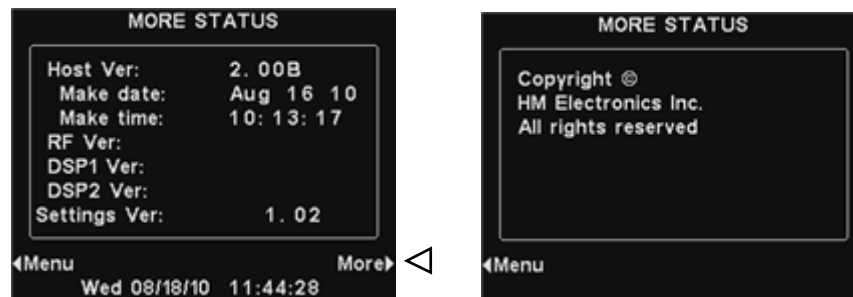

To view the **MAIN MENU**, which provides access to all of the system's settings, press the **Menu** button at the bottom-left of any **STATUS** or **MORE STATUS** display.

4.2 Basic Installer Setups

To access the Installer Setup mode, you must have an installer password. If you have an installer password, proceed as follows:

Press the **Menu** button on the **STATUS** display to access the **MAIN MENU**.

Press the **More** button on the **MAIN MENU** to access the **ADVANCED MENU**.



Press the **Installer setup** button on the **ADVANCED MENU** to access the **ENTER INSTALLER PASSWORD** display.

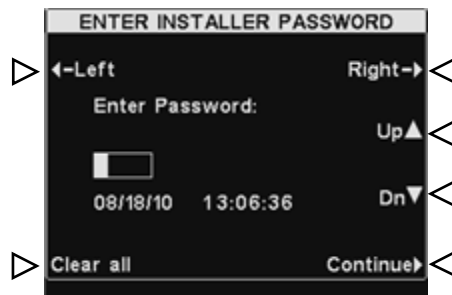

Enter the first character of the 4-digit password in the highlighted box in the **Enter Password** field by pressing the **Up** button to enter alphabetic characters, or the **Dn** (down) button to enter numbers. Press the **Right** button to move the highlighted box to the next position to the right. Repeat this procedure until all 4 digits of the password are entered, and then press the **Continue** button to access the **INSTALLER SETUP** display.

Note: If you make a mistake, you can use the **Left** and **Right** buttons to move the highlighted box to the necessary position and change the character entered there, or press the **Clear all** button to clear all entries and start over.

You can now proceed making the following installer settings from the **INSTALLER SETUP** display.



4.2.1 Lane Configuration

To set up the base station for the appropriate drive-thru lane configuration, press the **Lane configuration** button on the **INSTALLER SETUP** display to select **Single**, **Dual/Y** or **Tandem**.



Note: If the base station is a single-lane-only base station, only **Single** will be shown, and the **Lane configuration** button will be disabled.

4.2.2 Split-B Audio

Split-B audio is used only in dual-lane or tandem operations, to limit B audio transmission from Lane 1 to be heard only by other Lane 1 crew members, and B audio transmission from Lane 2 to be heard only by other Lane 2 crew members. When Split-B is not used, all B audio transmission from either lane is heard by crew members in both lanes.

To select Split-B operation, press the **Split B** button on the **INSTALLER SETUP** display and select **Split**. For single-lane drive-thrus, **Combined** should be selected.



4.2.3 Auto-Hands-Free

In the Auto Handsfree (AHF) mode, transmission and reception are activated automatically when a customer arrives at the menu board or speaker post. Communication is transmitted and received at the same time, as in a normal telephone conversation.

To set up the system to allow AHF operation, press the **Auto Handsfree** button on the **INSTALLER SETUP** display and select ✓(on). To turn AHF off, select -(off).



Note: Auto Handsfree is also a headset function. After selecting ✓(on) for the AHF function on the base, you must also set the headset(s) to the AHF mode before AHF will work.

4.2.4 Speaker Post

Select **Speaker post** on the **INSTALLER SETUP** display to access the **SPEAKER POST** display, to make the necessary outside speaker/microphone settings.

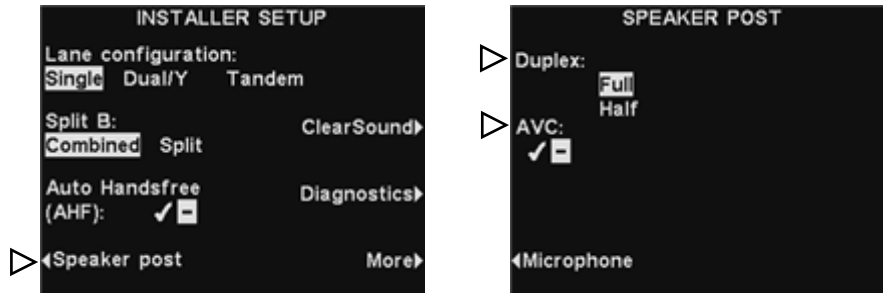

Press the **Duplex** button to select **Full** or **Half** duplex operation.

Press the **AVC** button to select ✓(on) or –(off) for AVC (Automatic Volume Control). When there is excessive outside noise, the level of the order taker’s voice in the speaker will be adjusted up. When it is quiet in the drive-thru area, the level will be adjusted down.

Press the **Microphone** button to make the following outside microphone settings.

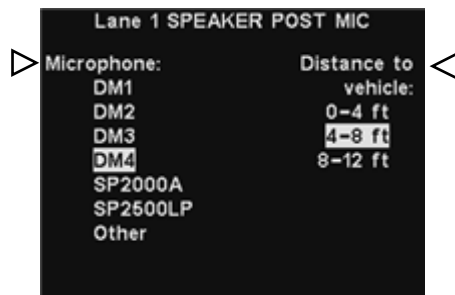

Select the type of microphone installed in the speaker post by pressing the **Microphone** button repeatedly until that microphone is highlighted.

Select the typical distance from the microphone to the vehicle in the drive-thru lane by pressing the **Distance to vehicle** button repeatedly until the correct distance is highlighted.

To save the setting, press the **Back** button.

4.2.5 ClearSound

ClearSound reduces environmental noises to improve the intelligibility of incoming voice transmission from the customer at the outside speaker. Press the **ClearSound** button on the **INSTALLER SETUP** display to access the **CLEAR SOUND** display.

To turn ClearSound noise cancellation on or off, press the **Noise cancel** button to highlight ✓(on) or –(off).

With the noise cancellation turned on, you can adjust the noise cancellation level by pressing the **Noise cancel lvl** button to highlight the desired level.

Echo cancellation reduces the operator's voice returning from the outside speaker to the headset as an echo. To turn echo cancellation on or off, press the **Echo cancel** button to highlight ✓(on) or –(off).

Note: **Echo cancel** will automatically be turned –(off) if half-duplex has been selected.

ANC (Automatic Noise Control) senses when a customer is speaking into the outside microphone, and reduces the incoming audio level when a customer is not speaking. To turn ANC on or off, press the **ANC** button to highlight ✓(on) or –(off).

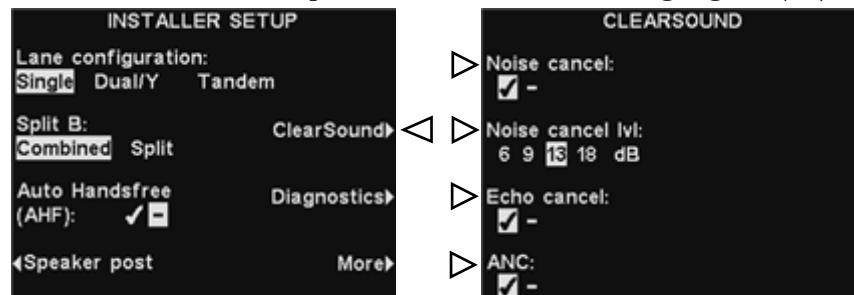

To save the setting, press the **Back** button.

4.2.6 Diagnostics

To have the ion |IQ™ perform diagnostic tests of various functions, press the **Diagnostics** button on the **INSTALLER SETUP** display.

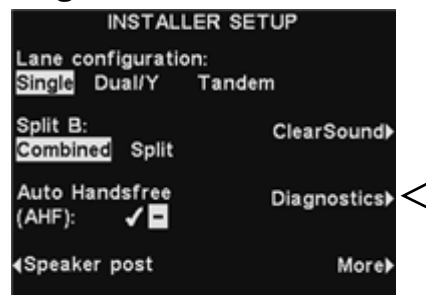

Note: Diagnostics are typically performed with guidance from HME Technical Support.

On the **DIAGNOSTICS** display, you can press the **More** button to see additional tests on the **ADVANCED DIAGNOSTICS** display.



On the left side of either display, press the button for the test to be performed.

4.3 Advanced Installer Setups

To perform the following advanced installer setups, press the **More** button on the **INSTALLER SETUP** display to access the **ADVANCED INSTALLER SETUP** display.

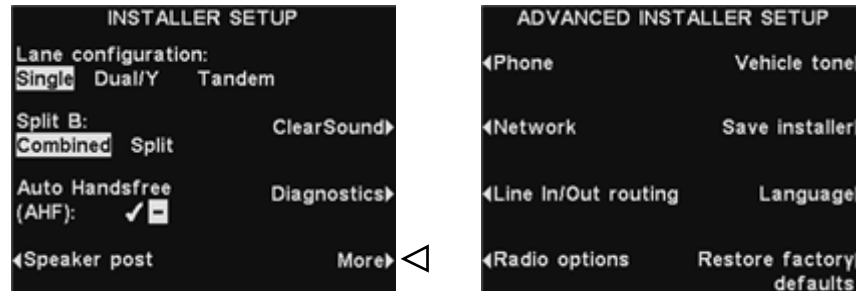

4.3.1 Phone

If a telephone is connected to the base station, to be used for telephone orders, the system must be set up for telephone operation. To do this, on the **ADVANCED INSTALLER SETUP** display press the **Phone** button. On the **PHONE SETTINGS** display, select (on). If a telephone will not be used, select (off).

To adjust the telephone outbound or inbound audio level, press the **Audio Out** or **Audio In** button and then press the **Up** or **Dn** (down) button to set the desired level.

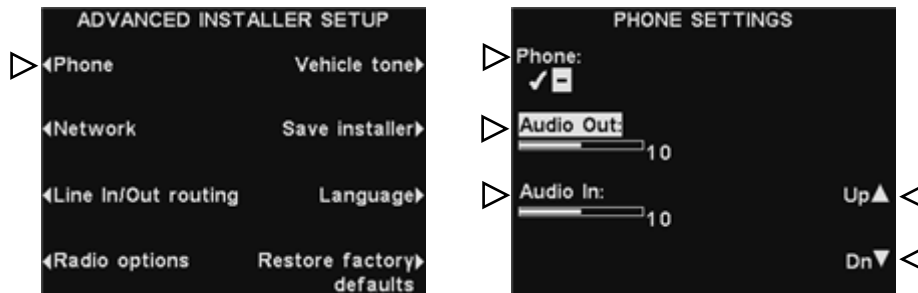

Note: When setting the **Phone** function to (on), you must also select a Phone Headset to receive the calls. See [Phone Headset](#) under Store Settings, [section 4.4.8](#). An optional Telephone Interface is also required. See [Figure 39](#), Optional Equipment Wiring Diagram

4.3.2 Network

If the base station is connected to a computer network for remote access, you must enter the network information. To do this, press the **Network** button on the **ADVANCED INSTALLER SETUP** display, to open the **NETWORK SETTINGS** display.



On the **NETWORK SETTINGS** display, you must press the button for each item you want to change. Each button pushed will cause a display to open, where you must enter the necessary address for network communication.

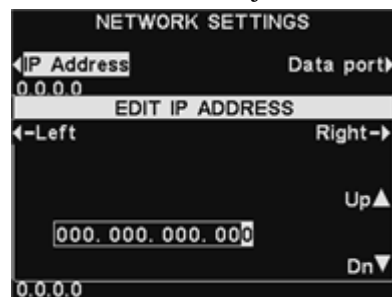

Note: The **EDIT IP ADDRESS** display is shown here as an example. However, the method of editing each of the network settings is the same.

To enter the first character in the highlighted position in the address box, press the **Up** or the **Dn** (down) button to enter numbers. Press the **Left** or **Right** button to move the highlighted position left or right, and repeat this procedure until the complete address is entered. When you have finished, press the **Back** button to return to the **NETWORK SETTINGS** display. Press the button for the next network setting, and fill in the information in the same way. When you have finished with all the network settings, press the **Back** button to return to the **ADVANCED INSTALLER SETUP** display and go on to the next setup.

Refer to Section 4.5, [PC Navigation](#) for instructions on how to use a PC for remote access.

4.3.3 Line In/Out Routing

If an external audio source is connected to the base station line input, press the **Line In to:** button to select **Inbound** for the audio from the external source to be heard in headsets and ceiling speakers, or wherever inbound audio would normally be heard. Select **Outbound** for the audio to be heard at the outside speaker.

If any device (e.g. recorder) is connected to the base station line output, press the **Line Out from:** button to select whether the audio from the **Ceiling** speaker, **Outbound** audio to the outside speaker, or messages from the **Message Ctr** will be routed to the device connected to the Line Output.

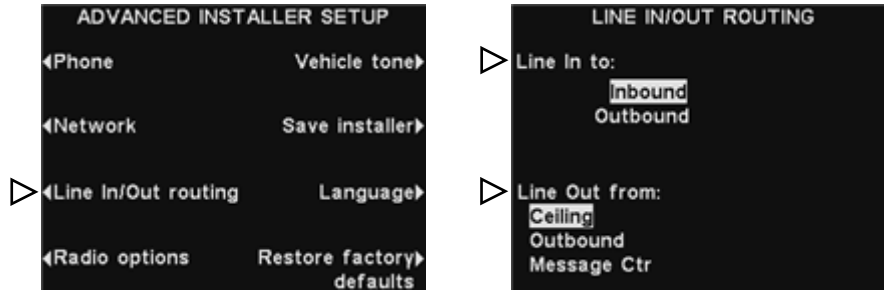

4.3.4 Radio Options

DO NOT CHANGE. Leave **RADIO OPTIONS** at factory default settings shown below. These functions are not yet supported.



4.3.5 Vehicle Tone

To set up an alert tone to be heard in all headsets when a vehicle arrives in the drive-thru lane, press the **Vehicle tone** button on the **ADVANCED INSTALLER SETUP** display, and then, on the **VEHICLE PRESENT TONE** display, press the **Vehicle Present** button to select ✓(on). Select –(off) to cancel the alert tone.

To have the alert tone repeated at 3-second intervals, until the Order Taker responds to the customer, press the **Repeat Interval** button and select ✓(on). Select –(off) to cancel the repeating alert tone, to have the tone sounded only once when a vehicle arrives.

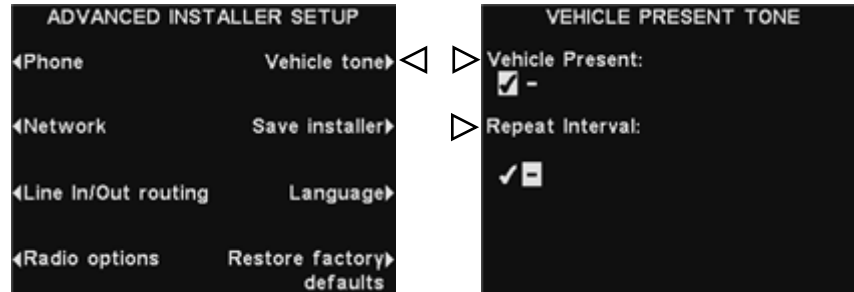

4.3.6 Save Installer Settings

To save all the settings you have made, press the **Save installer** button on the **ADVANCED INSTALLER SETUP** display. Your settings will be saved as Installer Settings. It is highly recommended that you perform this function at the end of the installation, so the user will have a backup of all installation specific settings.

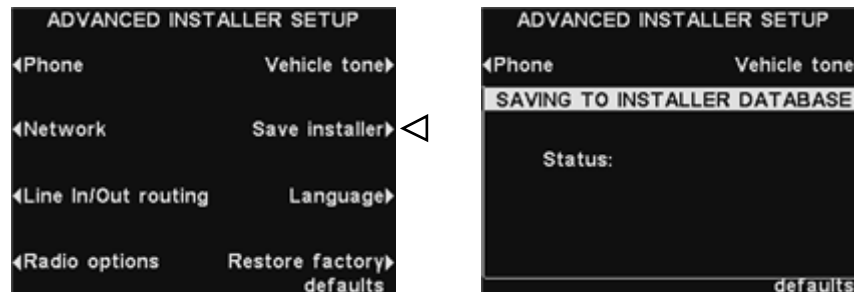

4.3.7 Language Selection

To select the language to be used, press the **Language** button on the **ADVANCED INSTALLER SETUP** display. On the **SELECT LANGUAGE** display, press the **Select language** button to highlight **English**, **Spanish** or **French**.

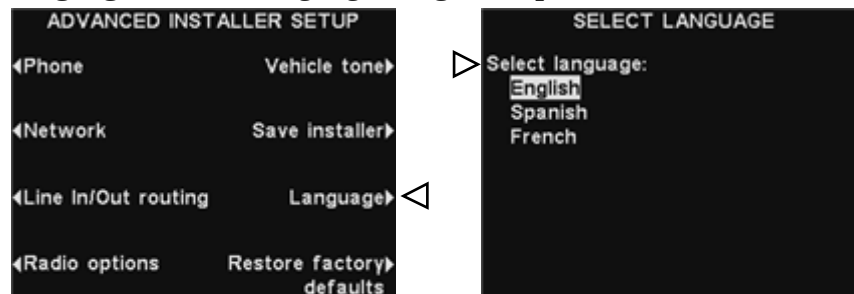

4.3.8 Restore Defaults

To erase all your settings and return the base station to its factory settings, press the **Restore factory defaults** button on the **ADVANCED INSTALLER SETUP** display, and then, if you are sure you want to change all settings back to factory defaults, press the **Default** button on the **RESTORE FACTORY DEFAULTS** display.

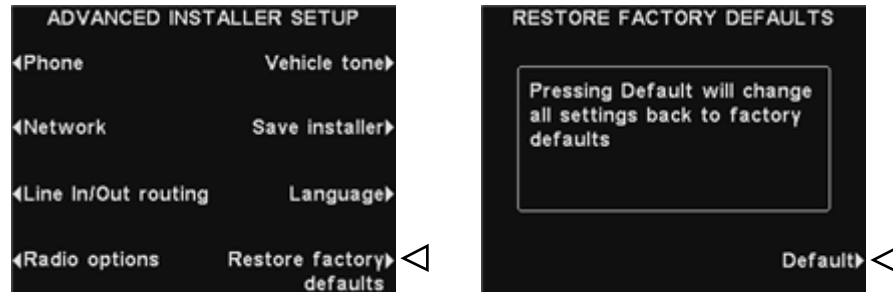

CAUTION: *If the base station is returned to its factory default settings, it will be set for English language operation. Refer to [section 8](#) to change the language back to Spanish or French.*

4.4 User Settings

User settings are for routine drive-thru operation. After you make the initial settings, store personnel can change the settings as needed. To access the user settings, press the **Menu** button on the **STATUS** display. Routine user settings are accessed from the **MAIN MENU**.

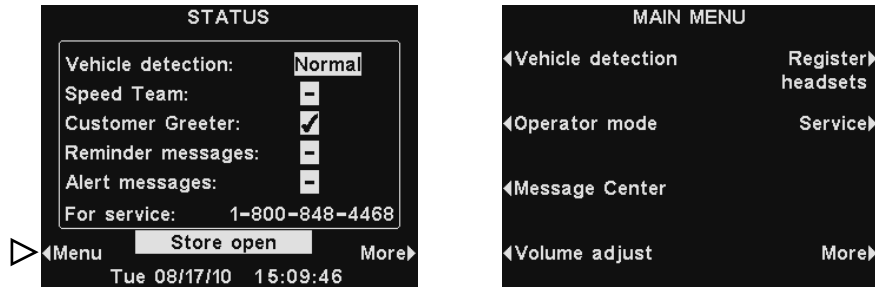

4.4.1 Vehicle Detection

To test the vehicle detector function by simulating a vehicle arrival at the speaker post or menu board, select **Menu** on the **STATUS** display and then press the **Vehicle detection** button on the **MAIN MENU**.

Note: Be sure no car (or metal object) is present at the detection point.

Press the **Mode** button on the **VEHICLE DETECTION** display and select **Override**. This will cause the vehicle alert tone to be played in headsets, followed by inbound audio from the outside speaker. To return to normal operation, press the **Mode** button again and select **Normal**.

If you experience a problem with vehicle detection, such as the inbound audio not shutting off from the outside speaker or no alert tone when a vehicle arrives, press the **Reset detector** button on the **VEHICLE DETECTION** display, and then press the **Yes** button to reset Vehicle Detector(s).

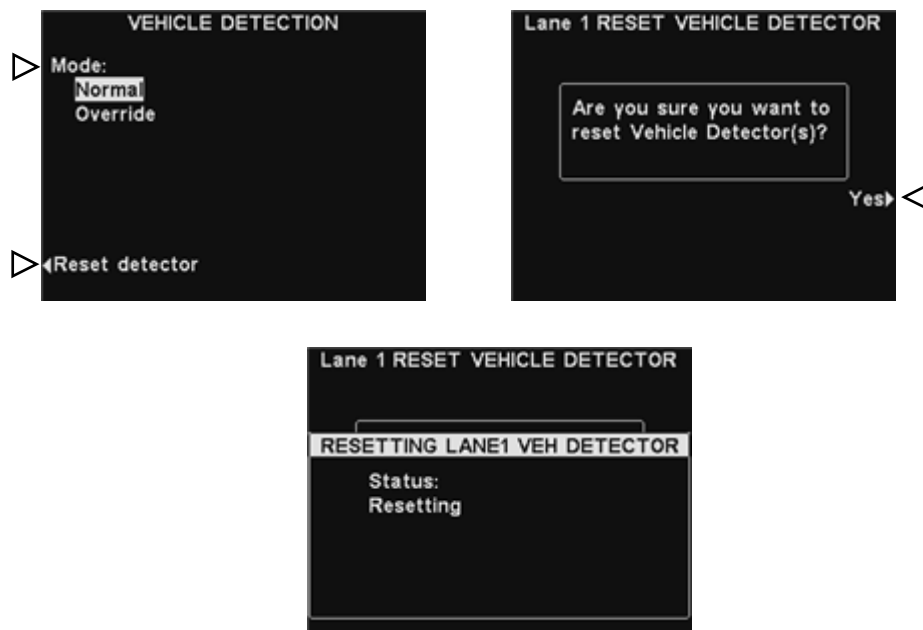

After **Reset Completed** appears and disappears on the display, press the **Back** button to exit.

4.4.2 Operator Mode

The Operator Mode provides **Speed Team** or **dedicated mode** settings. In Speed Team operation, audio and vehicle detection are disabled at the order point. Dedicated mode is a dual-lane setting. For single lane operations, this setting will not appear on the **OPERATOR MODE** display. In the dedicated mode, headset users only hear vehicle arrival tones and audio for their own lane.

Speed Team Operation

To set up Speed Team operation, select **Menu** on the **STATUS** display and then select **Operator mode** on the **MAIN MENU**. On the **OPERATOR MODE** display, press the **Turn Speed Team** button to select ✓(on).

If you select Turn Speed Team ✓(on), you must later select –(off) when you want to return to normal operation.

CAUTION: *With Speed Team ✓(on), many base station functions will be disabled. Vehicle arrival tones and the customer's voice will not be heard during Speed Team operation. For normal order taking, the Speed Team setting should be –(off).*

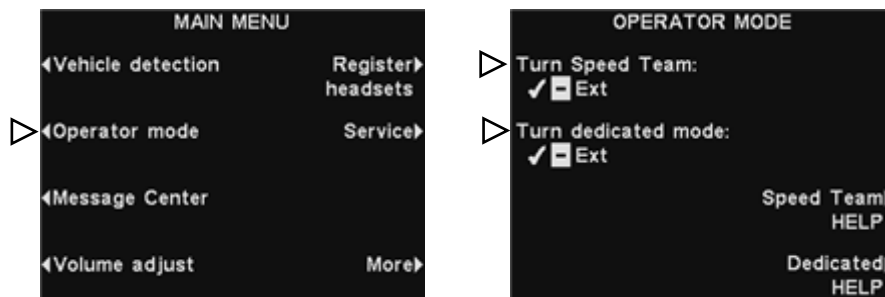

Select **Ext** only if Speed Team will be activated from a remote switch.

Note: In dual-lane operations only, the **Turn dedicated mode** selection and **Dedicated HELP** will appear on the **OPERATOR MODE** display as shown above. If you have a single-lane drive-thru, only the **Turn Speed Team** selection and **Speed Team HELP** will appear on the **OPERATOR MODE** display.

Dedicated Mode Operation

The dedicated mode is a dual-lane setting. In the dedicated mode, headset users only hear vehicle arrival tones and customers talking from their own lane.

To set up dedicated mode operation, select **Menu** on the **STATUS** display and then select **Operator mode** on the **MAIN MENU**. On the **OPERATOR MODE** display, press the **Turn dedicated mode** button to select ✓(on).

If you select Turn dedicated mode ✓(on), you must later select –(off) when you want to return to normal operation.

4.4.3 Message Center

The Message Center is a central point at which messages can be set up to be triggered by various events during designated time periods, to be sent to customers at the speaker post or to crew members via headsets or ceiling speakers.

Some messages are pre-named and pre-recorded. All messages can be customized to meet your specific requirements. The three types of messages are described below. The table on the next page shows the names and contents of factory pre-set messages. Following the table are detailed instructions of how to set up your Message Center. At the back of this manual you will find a Message Center Worksheet, for recording your message settings.

Note: Before continuing, it is important to consider all the possible time periods during which any of the Message Center messages need to be played in the store. Up to 12 time periods can be set up. You can use the Message Center Settings Worksheet at the back of this manual. When you have determined all the time periods needed, go to the Schedule Times section of these instructions to set up the time periods for the store before continuing with the Message Center setups. The current time and date, and store open and close times should also be set before other Message Center setups.

Customer Greeter messages

Customer Greeter messages are heard by the customer at the speaker post. They are typically used to greet customers and inform them of promotional items. Customer Greeter messages are pre-named but not pre-recorded, with the following exceptions; the Store Closed message and Pull Forward message (only for tandem drive-thrus) are pre-recorded. All Customer Greeter messages can be renamed and recorded or re-recorded to meet store needs.

Reminder messages

Reminder messages are heard by crew members in their headsets to remind them when routine tasks need to be done. Reminder messages can also be set to play in the ceiling speaker. There are 12 pre-named and pre-recorded Reminder messages that can be named and recorded to meet store needs. There are also 3 “Empty” messages that can be named and recorded as needed. Reminder messages can be sent to all headsets or targeted only to designated headsets.

Alert messages

Alert messages are heard by crew members in their headsets to let them know something that requires attention, such as a door being left open or a customer arriving in the store. Alert messages can be sent to all headsets or targeted only to designated headsets. Alert messages can also be set to play in the ceiling speaker. There are 4 pre-named and pre-recorded Alert messages that can be renamed and re-recorded to meet store needs. There are also 2 “Empty” messages that can be recorded and used for Alert messages, one of which can be used in single-lane operations, or both can be used in dual-lane operations. The remaining Empty 2-16 can only be triggered by network events that may be supported in the future.

Customer Greeter messages are triggered by detection of vehicles in the drive-thru lane, plus time and day.

Reminder messages are triggered by time and day only.

Alert messages are triggered by input signals, plus time and day or Network events.

MESSAGE CENTER MESSAGES		
NAME	CONTENT	
CUSTOMER GREETER	All Day 1	Not pre-recorded.
	All Day 2	Not pre-recorded.
	Breakfast 1	Not pre-recorded.
	Breakfast 2	Not pre-recorded.
	Lunch 1	Not pre-recorded.
	Lunch 2	Not pre-recorded.
	Snack 1	Not pre-recorded.
	Snack 2	Not pre-recorded.
	Dinner 1	Not pre-recorded.
	Dinner 2	Not pre-recorded.
	Store Closed	Thank you for your visit, but we are currently closed. Please visit us again during our normal business hours.
	Pull Forward *	Hello, please pull forward to the next speaker. Thanks. * (Tandem drive-thru only)
	REMINDER	Hand Washing
Sanitizer		Please change sanitizer solution.
DR Trash		Please check the dining room trash.
HAACP		Please complete the HAACP shift checklist.
Quality Check		Please complete the shift quality check.
Lot Check		Please complete a parking lot check.
Restroom Check		Please check the restrooms.
Pre-Rush		Please complete the pre-rush tasks for your workstation.
Post-Rush		Please complete the post-rush tasks for your workstation.
Headset Status		To check headset status, press and hold A2 and volume down while turning on the power.
Change Language		To change headset prompt language, press and hold A1 and volume down while turning on the power.
Hands Free ON		To turn headset hands free mode on, press and hold B and volume up while turning on the power.
Empty 1-3		Not pre-recorded.
ALERT		Freezer Door
	Cooler Door	The cooler door has been left open.
	Back Door	The back door has been left open.
	Lobby Door	A guest has entered the lobby.
	Empty 1	Not pre-recorded.
	Empty 2-16	Not pre-recorded.

1. Customer Greeter Message Settings

To set up the time periods and locations for Customer Greeter messages to be played, or to name and/or record Customer Greeter messages, press the **Menu** button on the base station **STATUS** display and then, on the **MAIN MENU** press the **Message Center** button.

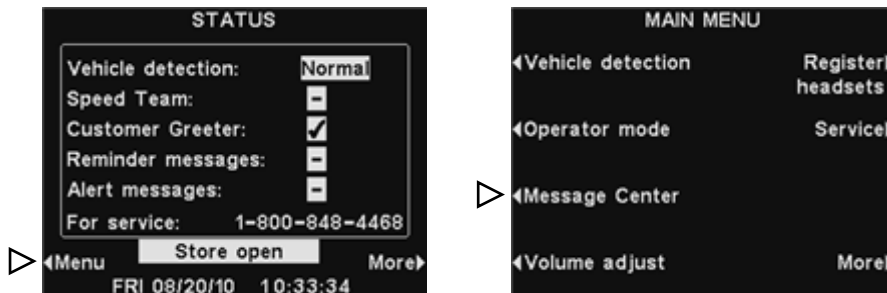

On the **MESSAGE CENTER MENU**, press the **Customer Greeter** button.



On the **CUSTOMER GREETER** display, to select a message for editing, press the **▲** (up) or **▼** (down) button to highlight the desired message.

To edit the selected message, press the **Edit** button.

Rename Message

To change the name of the selected message, press the **Rename** button on the **EDIT CUSTOMER GREETER** display.

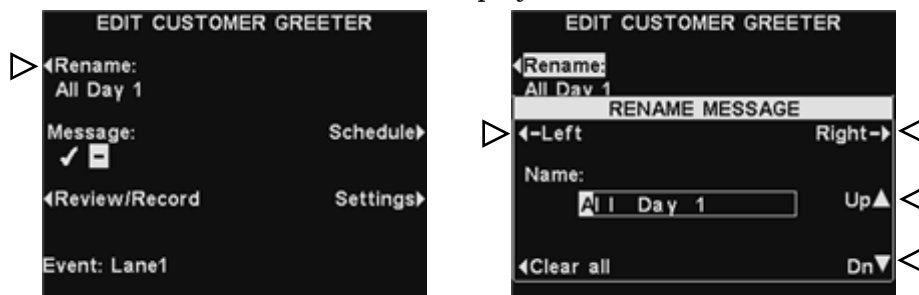

On the **RENAME MESSAGE** display, use the **Left** and **Right** buttons to move the highlight to a letter or number in the **Name** field that you would like to change, or press the **Clear All** button to delete/replace the entire name. Use the **Up** and **Dn** buttons to enter letters or numbers in the highlighted box, and use the **Right** button to move the box to the next position. When you are finished, press the **Back** button to save the new name.

Note: If you begin editing a name using only the **Up** button, you will go through all of the capitalized alphabet, followed by numbers and then lower case alphabet. Using only the **Dn** button, the characters will appear in reverse order. Each time you move the highlight to another position, the **Up** or **Dn** button will take you to the next character in sequence, following the last character you entered.

Turn Message On/Off

To turn the selected message on or off, press the **Message** button on the **EDIT CUSTOMER GREETER** display to highlight either ✓(on) or -(off). Press the **Back** button to save this setting.

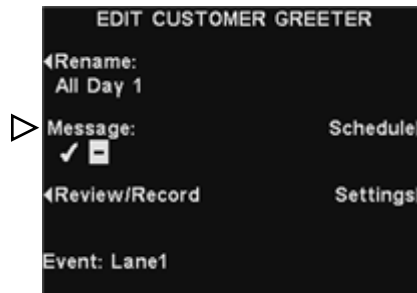

Review or Record Message

To review the existing selected message, or to record a new message, press the **Review/Record** button on the **EDIT CUSTOMER GREETER** display.



Note: Reviewed messages are played to all headsets. Messages may be reviewed only when no vehicles are present.

To listen to the existing message, press the **Review** button on the **REVIEW/RECORD MESSAGE** display. The message will be played in all headsets, and **REVIEWING MESSAGE...** will appear briefly on the display.



To record a new message, press the **Record** button on the **REVIEW/RECORD MESSAGE** display.



Follow the instructions under **READY TO RECORD** on the display. You will have up to 16 seconds to record a message while you are pressing and holding the headset **B** button. The **Progress** indicator will show you how much time you have left. When you finish recording, release the headset **B** button and press the **Review** button on the display to confirm a successful recording.

Message Schedule

To choose the schedule for the selected message, press the **Schedule** button on the **EDIT CUSTOMER GREETER** display.

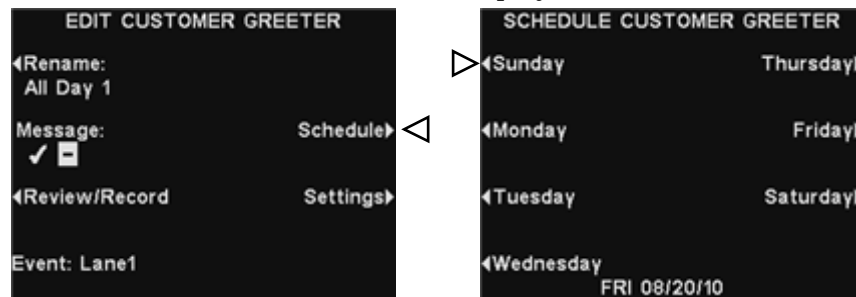

On the **SCHEDULE CUSTOMER GREETER** display, press the button for the day you want the selected message to be played.

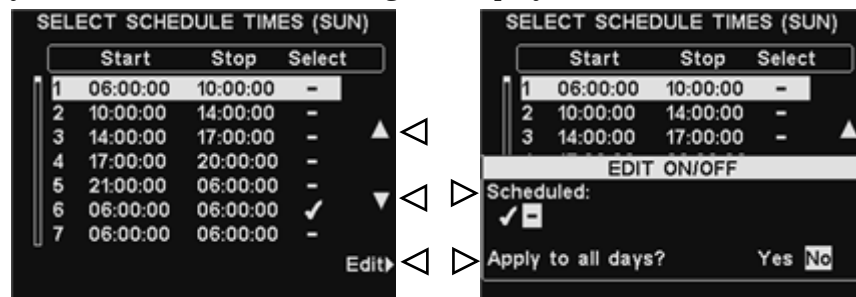

On the **SELECT SCHEDULE TIMES** display, select the time when you want the selected message to play by pressing the **▲** (up) and **▼** (down) buttons to scroll through the 12 available time periods. When the desired time period is highlighted, press the **Edit** button.

On the **EDIT ON/OFF** display, press the **Scheduled** button to turn the message **✓** (on) or **-** (off) for the selected time period. If you want the message to be on or off during this time period every day, press the **Apply to all days** button to select **Yes** or **No**. If **No** is selected, only the selected day will be affected by this change. Press the **Back** button to save this setting.

Note: To edit the **Start** and **Stop** times for the time periods listed on the **SELECT SCHEDULE TIMES** display, go to the **MESSAGE CENTER MENU** and select **Edit schedule times**.

Message Playback Settings

To edit where the selected Customer Greeter message will be heard (in addition to the speaker post), press the **Settings** button on the **EDIT CUSTOMER GREETER** display.

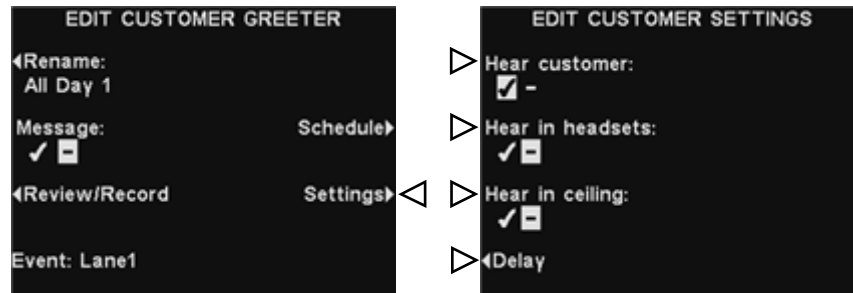

Note: Customer Greeter messages are always directed to the drive-thru speaker in addition to these settings. To stop playback to the drive-thru speaker requires setting the message volume to **0**. See [section 4.4.4](#). To hear the message at the drive-thru speaker also requires setting volume.

On the **EDIT CUSTOMER SETTINGS** display, press the button corresponding to the location where you would like the selected Customer Greeter message to be heard or not heard, to highlight ✓(on) or -(off).

If you select **Hear customer: ✓**(on), you will hear a customer at the speaker post, together with the selected Customer Greeter message. If you select **Hear customer: -(off)**, you will not hear the customer until the message playback has completed.

The **Hear in headsets** and **Hear in ceiling** speaker settings allow you to choose whether or not to hear the selected Customer Greeter message in those locations.

If you would like a delay after the Customer Greeter message is triggered until it begins playing, on the **DELAY BEFORE PLAY** display, use the **Up** and **Dn** buttons to change the number in the highlighted box, and use the **Left** or **Right** button to move the highlight to the opposite position.

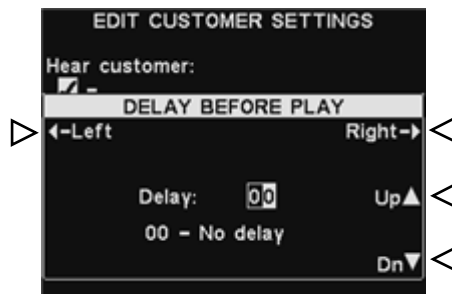

When you are finished, press the **Back** button to save the setting.

2. Reminder Message Settings

To set up the time periods and locations for Reminder messages to be played, or to name and/or record Reminder messages, press the **Menu** button on the base station **STATUS** display and then, on the **MAIN MENU** press the **Message Center** button.

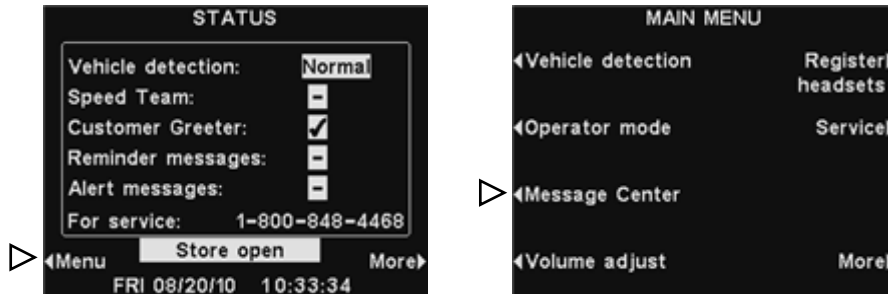

On the **MESSAGE CENTER MENU**, press the **Reminder messages** button.

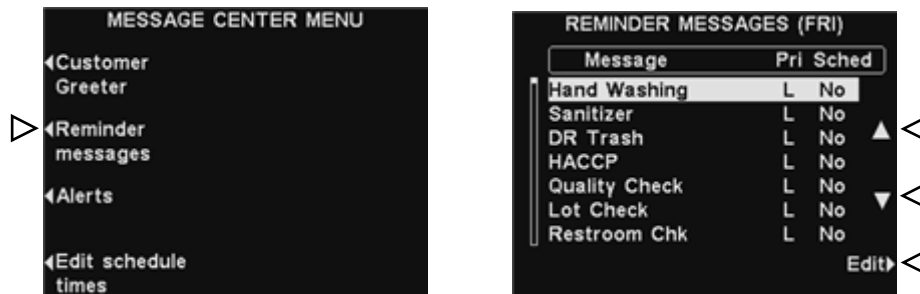

To select a message on the **REMINDER MESSAGES** display, press the **▲**(up) or **▼**(down) button to highlight the desired message. To edit the highlighted message, press the **Edit** button.

Rename Message

To change the name of the selected message, press the **Rename** button on the **EDIT REMINDER MESSAGE** display.

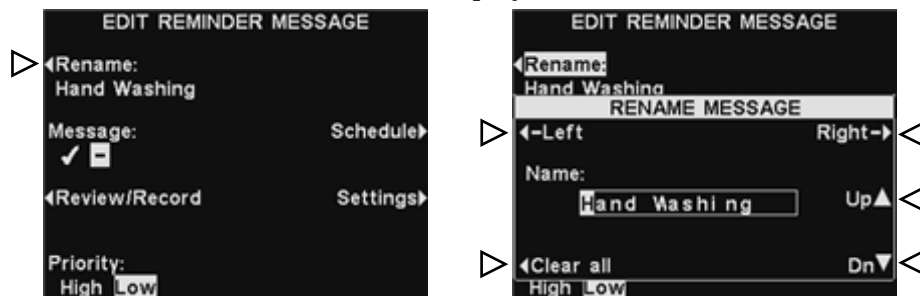

On the **RENAME MESSAGE** display, use the **Left** and **Right** buttons to move the highlight to a letter or number in the **Name** field that you would like to change, or press the **Clear All** button to delete/replace the entire name. Use the **Up** and **Dn** buttons to enter letters or numbers in the highlighted box, and use the **Right** button to move the box to the next position. When you are finished, press the **Back** button to save the new name.

Note: If you begin editing a name using only the **Up** button, you will go through all of the capitalized alphabet, followed by numbers and then lower case alphabet. Using only the **Dn** button, the characters will appear in reverse order. Each time you move the highlight to another position, the **Up** or **Dn** button will take you to the next character in sequence, following the last character you entered.

Turn Message On/Off

To turn the selected message on or off, press the **Message** button on the **EDIT REMINDER MESSAGE** display to highlight either ✓(on) or -(off). Press the **Back** button to save this setting.

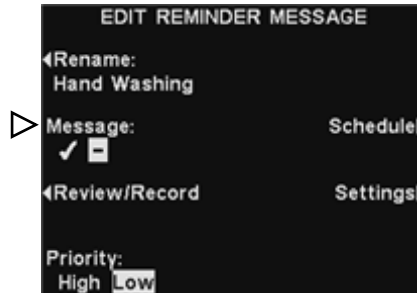

Review or Record Message

To review the existing selected message, or to record a new message, press the **Review/Record** button on the **EDIT REMINDER MESSAGE** display.



Note: Reviewed messages are played to all headsets. Messages may be reviewed only when no vehicles are present.

To listen to the existing message, press the **Review** button on the **REVIEW/RECORD MESSAGE** display. The message will be played in all headsets, and **REVIEWING MESSAGE...** will appear briefly on the display.



To record a new message, press the **Record** button on the **REVIEW/RECORD MESSAGE** display.



Follow the instructions under **READY TO RECORD** on the display. You will have up to 10 seconds to record a message while you are pressing and holding the headset **B** button. The **Progress** indicator will show you how much time you have left. When you finish recording, release the headset **B** button and press the **Review** button on the display to confirm a successful recording.

Message Priority

To set message priority, press the **Priority** button on the **EDIT REMINDER MESSAGE** display to highlight either **High** or **Low**. Press the **Back** button to save this setting.

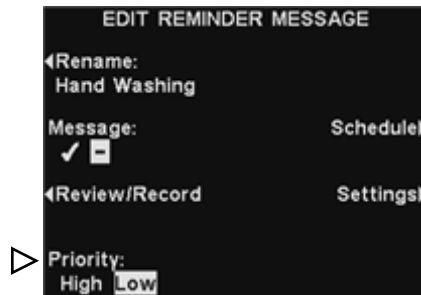

Note: If a low priority Reminder message is scheduled to be played when communication with a customer is ongoing, the message will be cancelled. If a high priority Reminder message is scheduled to be played when communication with a customer is ongoing, the message will be played after communication with the customer ends.

Message Schedule

To choose the schedule for the selected message, press the **Schedule** button on the **EDIT REMINDER MESSAGE** display.

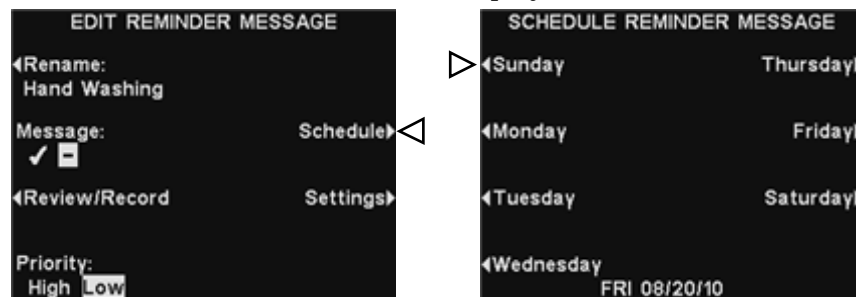

On the **SCHEDULE REMINDER MESSAGE** display, press the button for the day you want the selected message to be played.

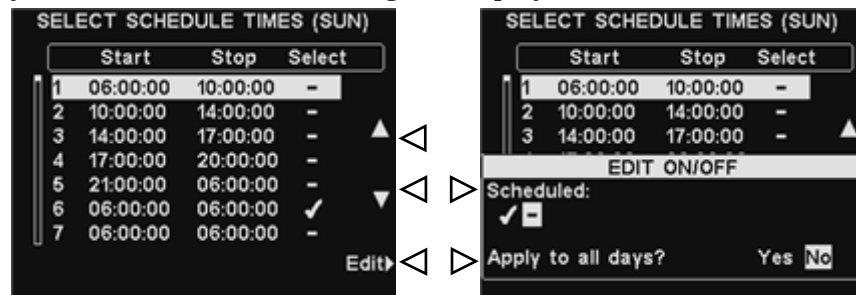

On the **SELECT SCHEDULE TIMES** display, select the time when you want the selected message to play by pressing the **▲** (up) and **▼** (down) buttons to scroll through the 12 available time periods. When the desired time period is highlighted, press the **Edit** button.

On the **EDIT ON/OFF** display, press the **Scheduled** button to turn the message **✓** (on) or **-** (off) for the selected time period. If you want the message to be on or off during this time period every day, press the **Apply to all days** button to select **Yes** or **No**. If **No** is selected, only the selected day will be affected by this change. Press the **Back** button to save this setting.

Note: To edit the **Start** and **Stop** times for the time periods listed on the **SELECT SCHEDULE TIMES** display, go to the **MESSAGE CENTER MENU** and select **Edit schedule times**.

Message Playback Settings

To choose where the selected Reminder message will be heard, press the **Settings** button on the **EDIT REMINDER MESSAGE** display.

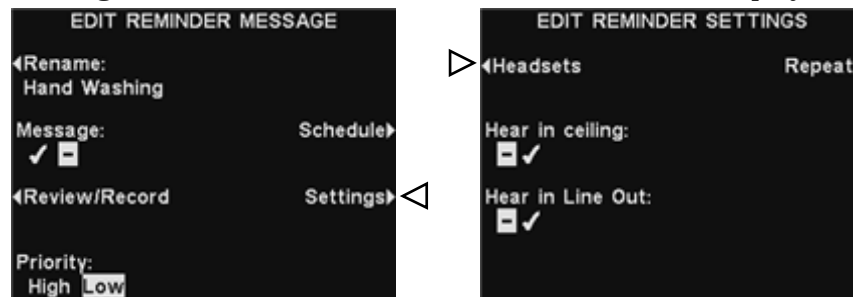

To designate headsets where you would like the selected Reminder message to be heard, press the **Headsets** button on the **EDIT REMINDER SETTINGS** display.

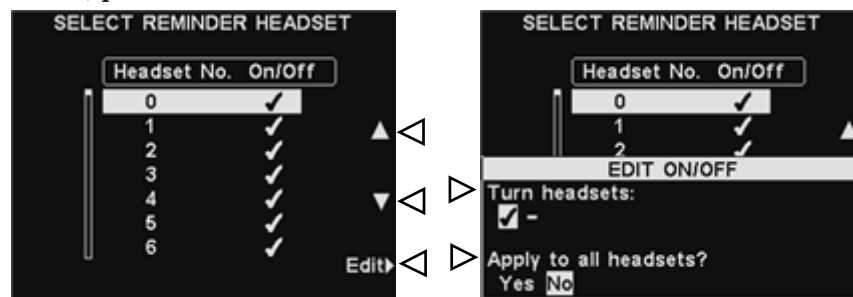

On the **SELECT REMINDER HEADSET** display, use the ▲ (up) or ▼ (down) buttons to select a headset number for which you would like to turn the selected Reminder message ✓ (on) or - (off), and then press the **Edit** button.

To turn the message ✓ (on) or - (off) in the selected headset, press the **Turn Headsets** button on the **EDIT ON/OFF** display to highlight ✓ (on) or - (off). To turn the message ✓ (on) or - (off) in all headsets, press the **Apply to all headsets?** button to highlight **Yes** or **No**. Press the **Back** button to save this setting.



To have the selected Reminder message heard in the ceiling speaker(s), or not heard, press the **Hear in ceiling** button to highlight ✓ (on) or - (off).

To have the selected Reminder message heard in the line out(s), or not heard, press the **Hear in Line Out** button to highlight ✓ (on) or - (off).

Note: After selecting ✓ (on), to hear the Reminder message in the Ceiling Speaker or Line Out, you must also be sure their volume is set high enough for the message to be audible. To do this, return to the **MAIN MENU** and select **Volume adjust**, and make the necessary adjustments.

To have the Reminder message repeated at selected intervals, press the **Repeat** button on the **EDIT REMINDER SETTINGS** display, and use the **Left** or **Right** button to move the highlight left or right for hours, minutes or seconds (HH:MM:SS) in the **Time** field, and use the **Up** and **Dn** buttons to change the number in the highlighted box.

When you are finished, press the **Back** button to save the setting.

3. Alert Message Settings

To set up the time periods and locations for Alert messages to be played, or to name and/or record Alert messages, press the **Menu** button on the base station **STATUS** display and then, on the **MAIN MENU** press the **Message Center** button.

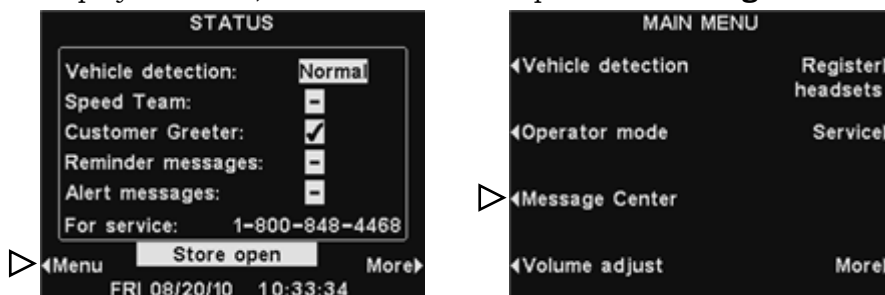

Press the **Alerts** button on the **MESSAGE CENTER MENU**.

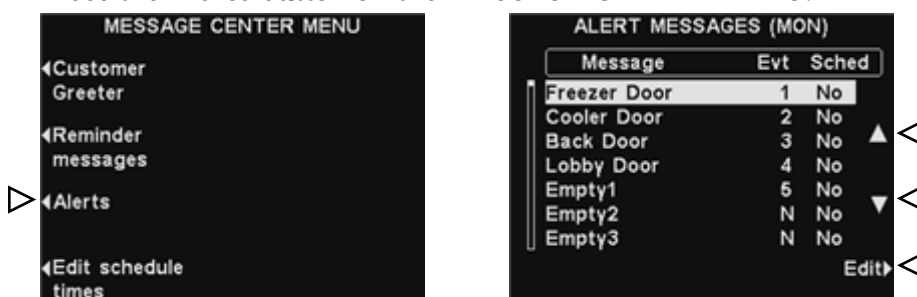

Note: Only the first 5 Empty messages are usable. Other messages only have network event triggers (N), which are not yet supported.

To select a message on the **ALERT MESSAGES** display, press the **▲**(up) or **▼**(down) button to highlight the desired message. To edit a message, select the message and press the **Edit** button.

Rename Message

To change the name of the selected message, press the **Rename** button on the **EDIT ALERT MESSAGE** display.

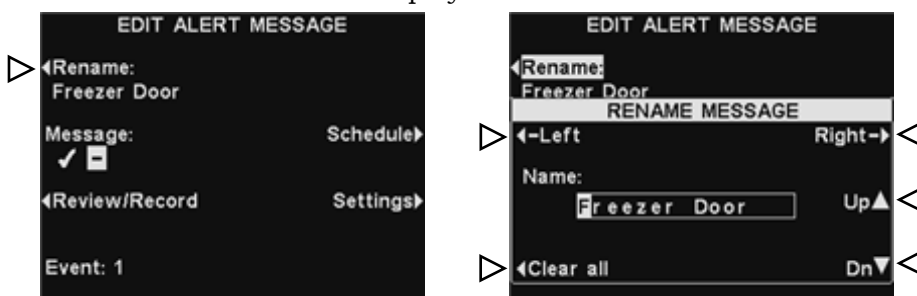

On the **RENAME MESSAGE** display, use the **Left** and **Right** buttons to move the highlight to a letter or number in the **Name** field that you would like to change, or press the **Clear All** button to delete/replace the entire name. Use the **Up** and **Dn** buttons to enter letters or numbers in the highlighted box, and use the **Right** button to move the box to the next position.

Note: If you begin editing a name using the **Up** button, you will go through all of the capitalized alphabet, followed by numbers and then lower case alphabet. Using the **Dn** button, the characters will appear in reverse order. Each time you move the highlight to another position, the **Up** or **Dn** button will take you to the next character in sequence, following the last character you entered.

When you are finished, press the **Back** button to save the new name.

Turn Message On/Off

To turn the selected message on or off, press the **Message** button on the **EDIT ALERT MESSAGE** display to highlight either ✓(on) or -(off). Press the **Back** button to save this setting.



Review or Record Message

To review the existing selected message, or to record a new message, press the **Review/Record** button on the **EDIT ALERT MESSAGE** display.



Note: Reviewed messages are played to all headsets. Messages may be reviewed only when no vehicles are present.

To listen to the existing message, press the **Review** button on the **REVIEW/RECORD MESSAGE** display. The message will be played in all headsets, and **REVIEWING MESSAGE...** will appear briefly on the display.



To record a new message, press the **Record** button on the **REVIEW/RECORD MESSAGE** display.



Follow the instructions under **READY TO RECORD** on the display. You will have up to 10 seconds to record a message while you are pressing and holding the headset **B** button. The **Progress** indicator will show you how much time you have left. When you finish recording, release the headset **B** button and press the **Review** button on the display to confirm a successful recording.

Message Schedule

To choose the schedule for the selected message, press the **Schedule** button on the **EDIT ALERT MESSAGE** display.

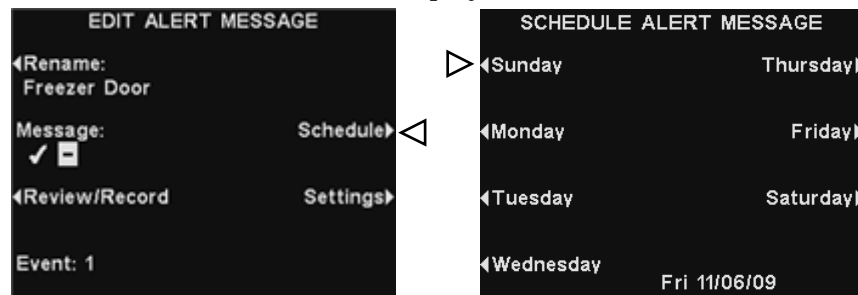

On the **SCHEDULE ALERT MESSAGE** display, press the button for the day you want the selected message to be played.

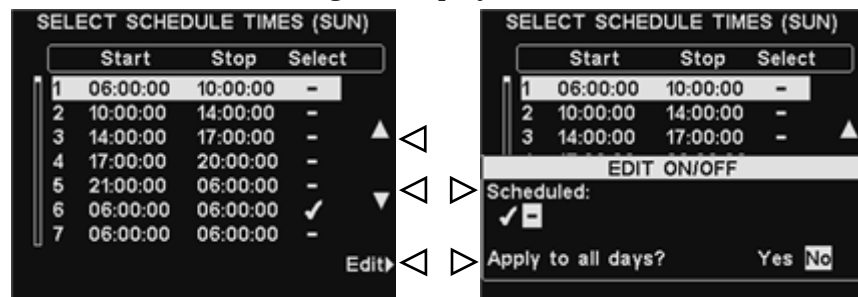

On the **SELECT SCHEDULE TIMES** display, select the time when you want the selected message to play by pressing the **▲** (up) and **▼** (down) buttons to scroll through the 12 available time periods. When the desired time period is highlighted, press the **Edit** button.

On the **EDIT ON/OFF** display, press the **Scheduled** button to turn the message **✓** (on) or **-** (off) for the selected time period. If you want the message to be on or off during this time period every day, press the **Apply to all days** button to select **Yes** or **No**. If **No** is selected, only the selected day will be affected by this change. Press the **Back** button to save this setting.

Note: To edit the **Start** and **Stop** times for the time periods listed on the **SELECT SCHEDULE TIMES** display, go to the **MESSAGE CENTER MENU** and select **Edit schedule times**.

Message Playback Settings

To choose where the selected Alert message will be heard, press the **Settings** button on the **EDIT ALERT MESSAGE** display.

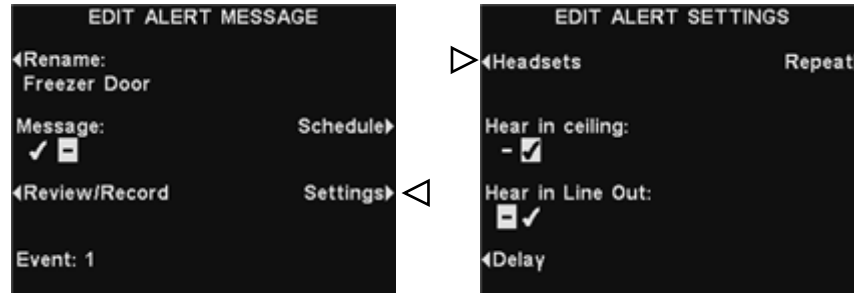

To designate specific headsets where the selected Alert message will be heard, press the **Headsets** button on the **EDIT ALERT SETTINGS** display.

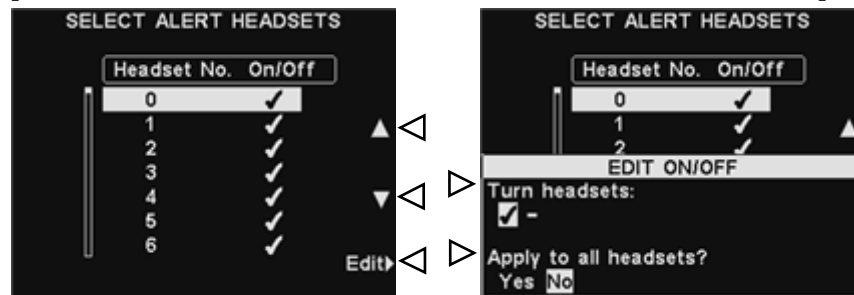

On the **SELECT ALERT HEADSETS** display, use the **▲** (up) and **▼** (down) buttons to select a headset number for which you would like to turn the selected Alert message on/off, and then press the **Edit** button. To turn the message on or off in the selected headset, press the **Turn Headsets** button on the **EDIT ON/OFF** display to highlight **✓** (on) or **-** (off). To turn the message on or off in all headsets, press the **Apply to all headsets?** button to highlight **Yes** or **No** and then press the **Back** button.

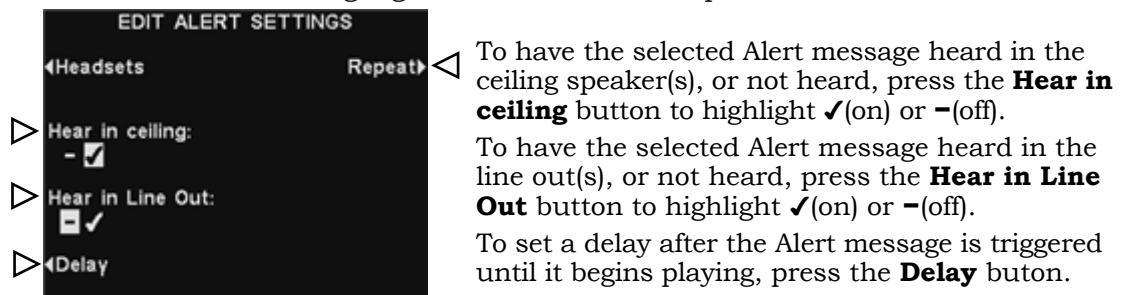

To have the selected Alert message heard in the ceiling speaker(s), or not heard, press the **Hear in ceiling** button to highlight **✓** (on) or **-** (off).
 To have the selected Alert message heard in the line out(s), or not heard, press the **Hear in Line Out** button to highlight **✓** (on) or **-** (off).
 To set a delay after the Alert message is triggered until it begins playing, press the **Delay** button.

On the **DELAY BEFORE PLAY** display, use the **Left** or **Right** button to move the highlight left or right in the **Delay** field for minutes and seconds (MM:LL), and use the **Up** and **Dn** buttons to change the number in the highlighted box.



To have the Alert message repeated at selected intervals, press the **Repeat** button on the **EDIT ALERT SETTINGS** display. On the **REPEAT INTERVAL** display, use the **Left** or **Right** button to move the highlight left or right in the **Time** field for hours, minutes or seconds (HH:MM:SS), and use the **Up** and **Dn** buttons to change the number in the highlighted box.

To save these settings, press the **Back** button.

4. Schedule Times

To set up all the time periods during each day, in which all Message Center messages can be scheduled, press the **Menu** button on the base station **STATUS** display and then, on the **MAIN MENU** press the **Message Center** button.

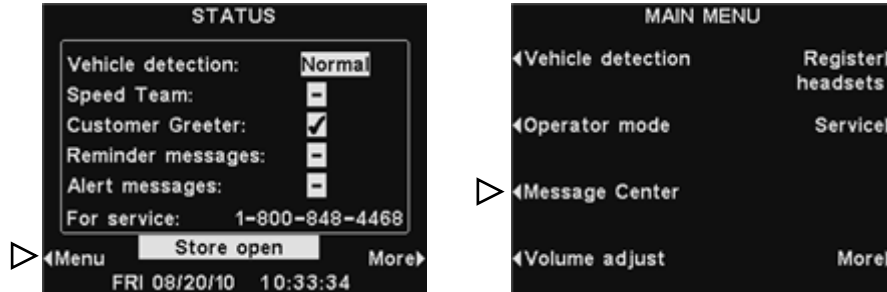

Press the **Edit schedule times** button on the **MESSAGE CENTER MENU**.



There are 12 possible time periods.

Note: Changing these time periods will affect all Message Center message schedules.

To select a time period to be edited, use the **▲**(up) and **▼**(down) buttons to scroll through the 12 available time periods. When the desired time period is highlighted, press the **Edit** button.

On the drop-down **EDIT SCHEDULE TIMES** display, to edit the Start or Stop time, use the **Left** and **Right** buttons to move the highlight in the **Start** or **Stop** field, and use the **Up** and **Dn** buttons to change the highlighted numbers.

Note: Times are in 24 hour format.

example - 0500 = 5 A.M.
1700 = 5 P.M.
0000 = Midnight

To move from one field to the other, repeat pressing the **Left** or **Right** button until the highlight moves from one field to the other.

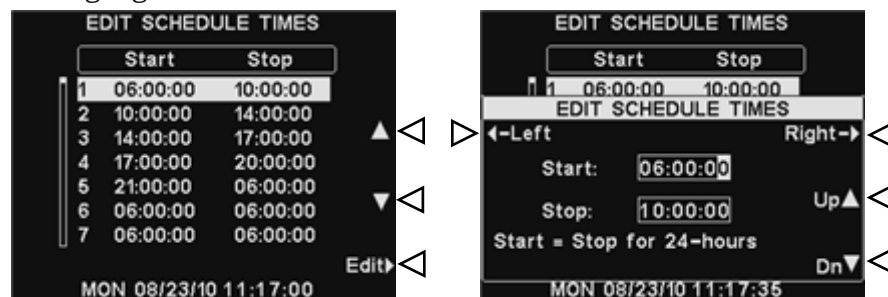

To save these settings, press the **Back** button.

4.4.4 Volume Adjustments

To adjust the volume of inbound and outbound audio, alert tones and message repeater messages, on the base station **STATUS** display, select **Menu** and then, on the **MAIN MENU** select **Volume adjust**.

Note: If you have a dual lane operation, the **VOLUME MENU** will have the same selections for **Lane 1** and **Lane 2** as shown here on the **VOLUME MENU**. Make your selections accordingly.

Press the button on the left side of the **VOLUME MENU** to select which volume you want to adjust.

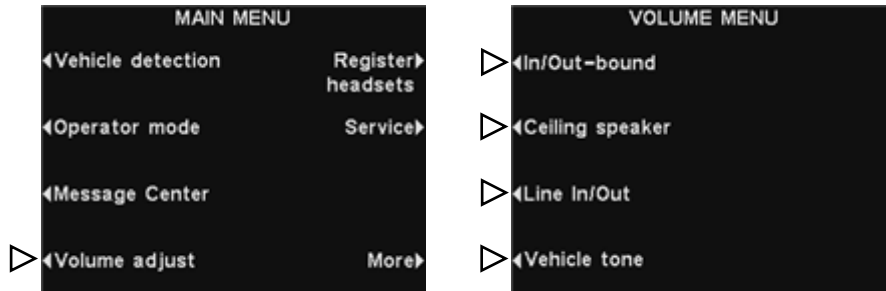

On the next display that appears, select which volume you would like to adjust, and then use the **Up** and **Dn** buttons to raise and lower the volume level.

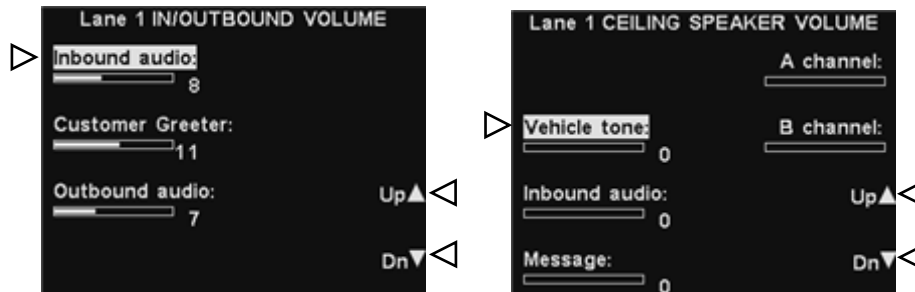

Note: **IN/OUTBOUND VOLUME** settings adjust the level to and from the outside speaker/microphone and the level of the outbound message from the Message Center. If a volume is set to **0**, that function is effectively turned off and no audio is heard at all. The **VEHICLE TONE VOLUME** setting only adjusts the level of the alert tone heard in the headsets.

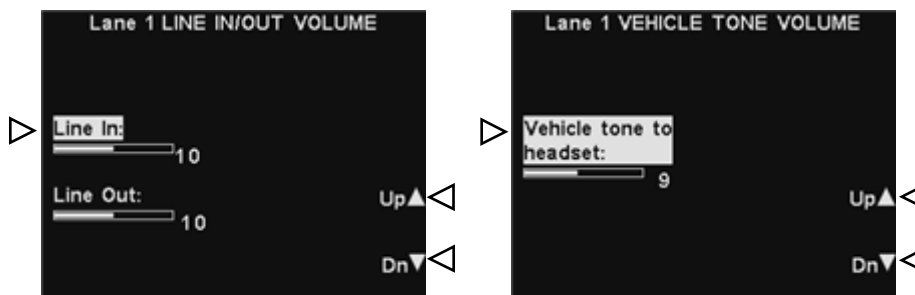

To save these settings, press the **Back** button.

4.4.5 Register COMMUNICATOR®s

Each Communicator must be “registered” to the base station, so the base station will recognize it when its power is on, and will be able to tell the difference between it and other electronic equipment operating on similar frequencies. If a Communicator is replaced, you must register the new one before you use it.

To register Communicators to the base station, see [Section 3.1.3](#).

4.4.6 Service

For HME Technical Support contact information, select **Menu** on the **STATUS** display and then select **Service** on the **MAIN MENU**.

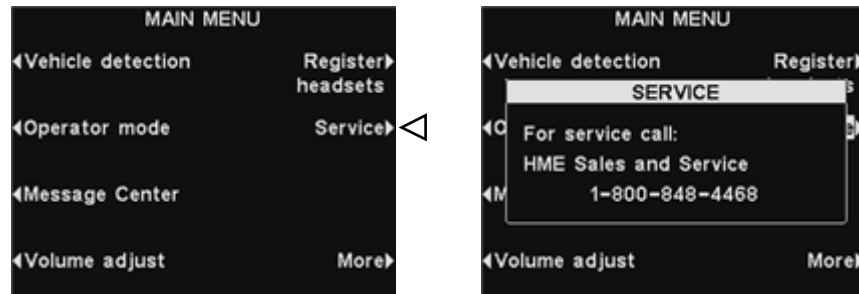

4.4.7 Installer Setup

See [Section 4.2](#) for Basic Installer Setups and [Section 4.3](#) for Advanced Installer Setups.

4.4.8 Store Settings

Store settings are crucial to drive-thru operation. After you make the initial settings, they can be changed by store managers or other authorized personnel.

After you have made all store settings, set up a password to control access to store settings, and give the password to the store manager.

To access the **STORE SETTINGS** display, press the **More** button on the **MAIN MENU** and then press the **Store settings** button on the **ADVANCED MENU**.



Set Date or Time

To set the date or time, press the **Set date** or **Set time** button on the **STORE SETTINGS** display.

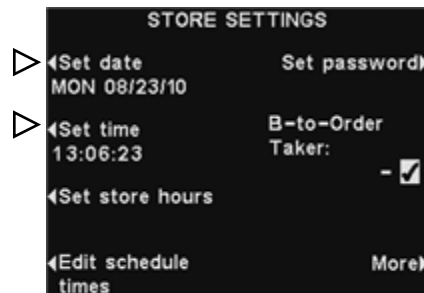

Note: All times are in 24-hour format.

On the **SET DATE** or **SET TIME** display, use the **Left** and **Right** buttons to move the highlighted box to the left and right in the **Date** or **Time** field, and use the **Up** and **Down** buttons to enter the desired number in the highlighted box.

HINT! When setting the time, set it a little in advance of the known correct time and then, when the correct time matches the setting, press the **Back** button.

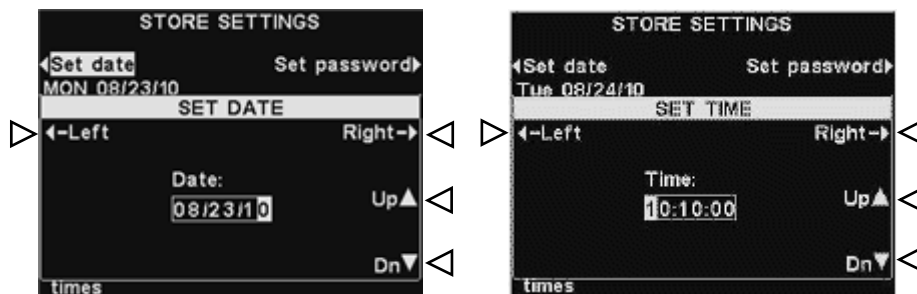

To save the setting and return to the **STORE SETTINGS** display, press the **Back** button.

Set Store Hours

To set the store hours for any or every day, press the **Set store hours** button on the **STORE SETTINGS** display.

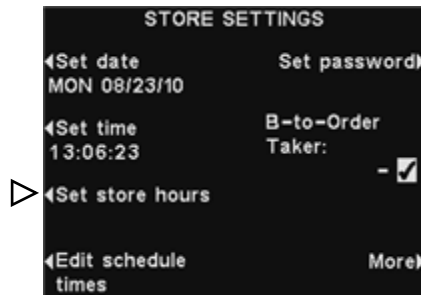

On the **STORE HOURS** display, press the button next to the day you would like to change.

On the **SET STORE HOURS** display, use the **Left** and **Right** buttons to move the highlight in the **Open** or **Close** field, and use the **Up** and **Dn** buttons to change the highlighted numbers. To move from one field to the other, repeat pressing the **Left** or **Right** button until the highlight moves to the other field.

Note: If your store is open 24 hours, set the **Open** time the same as the **Close** time.

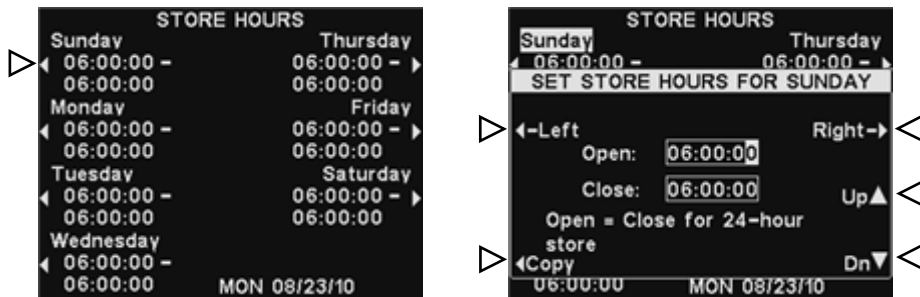

If you want these store hours to apply to every day, press the **Copy** button and then press the **Apply to all days?** button to highlight **Yes**. If **No** is highlighted, these store hours will apply only to the selected day.

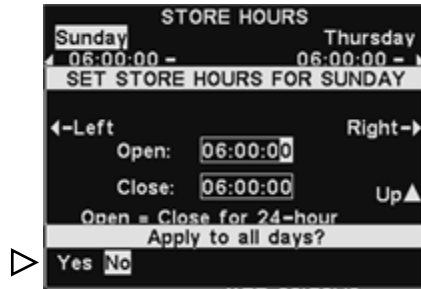

To save these settings, press the **Back** button.

Edit Schedule Times

Up to 12 Schedule Times can be set to establish periods in which messages can be played from the Message Center. Schedule Times can be edited as needed. To make changes to the Schedule Times, press the **Edit schedule times** button on the **STORE SETTINGS** display.

Note: The **EDIT SCHEDULE TIMES** display can also be accessed through the **MESSAGE CENTER**.

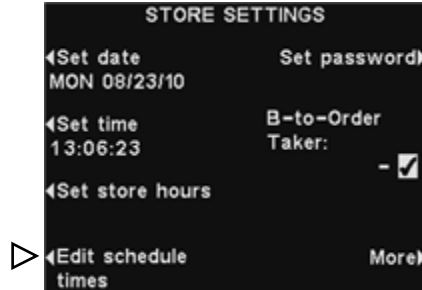

On the **EDIT SCHEDULE TIMES** display, press the **▲** (up) and **▼** (down) buttons to move up and down the list of time periods. You can continue pressing the **Dn** button past 7 until you reach 12. When the time period you would like to change is highlighted, press the **Edit** button.

Note: Changing these time periods will affect all Message Center message schedules.

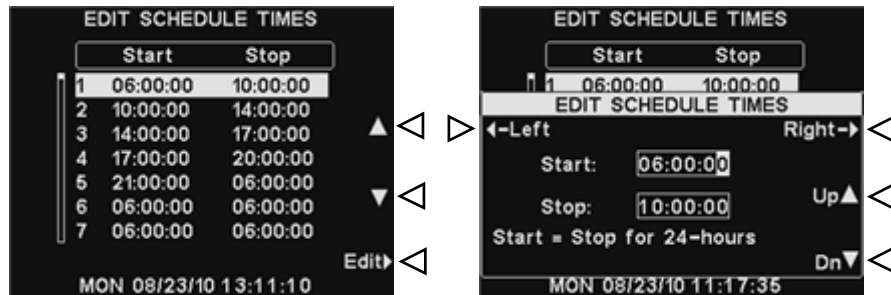

Use the **Left** and **Right** buttons to move the highlight in the **Start** or **Stop** field, and then use the **Up** and **Dn** buttons to change the highlighted numbers. To move from one field to the other, repeat pressing the **Left** or **Right** button until the highlight moves beyond the end of one field and into the other.

Note: If your store is open 24 hours, and you want a schedule to run for 24 hours, set the **Stop** time the same as the **Start** time.

To save these settings, press the **Back** button.

Set Password

When you have completed all the other Store Settings, set up a user password. When the installation is finished, be sure to give the password to the store manager. To set a password for the first time, press the **Set password** button on the **STORE SETTINGS** display.

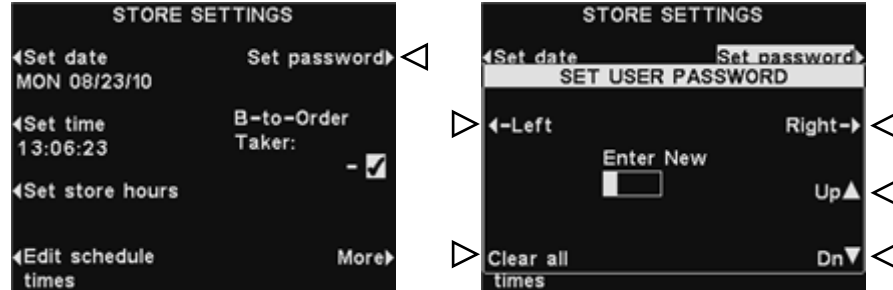

Use the **Left** and **Right** buttons to move the highlighted box in the **Enter New** field. Use the **Up** button to put alphabetic characters in the highlighted box, or the **Dn** button to put numeric characters in the highlighted box. Continuing down from A will take you to numeric characters. Continuing up from 9 will take you to alphabetic characters. Press the **Right** button to move the highlighted box to the next position and enter the next character. If you want to start over with a new password, press the **Clear All** button. After entering the entire new password, press the **Back** button twice to save the new password and return to the **ADVANCED MENU**.

B-to-Order Taker

The **B-to-Order Taker** feature allows the Order Taker to hear (or not hear) **B** button communication during **A** button communication with a customer.

Press the **B-to-Order Taker** button on the **STORE SETTINGS** display to select (on) to allow the Order Taker to hear **B** button communication while pressing an **A** button. If you select (off), the Order Taker will not hear **B** button communication while pressing an **A** button.

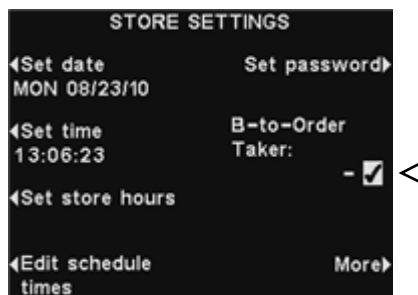

To save this setting, press the **Back** button.

VAA Settings

VAA settings can be adjusted to eliminate echo, feedback or fluctuating inbound audio levels. To turn the VAA feature on/off, or to adjust VAA levels, press the **More** button on the **STORE SETTINGS** display. On the **ADVANCED STORE SETTINGS** display, press the **VAA** button.

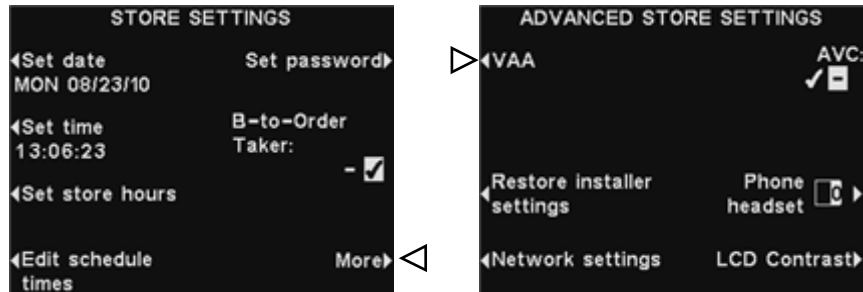

Note: If you have a dual lane drive-thru operation, you may need to make this adjustment for each lane.

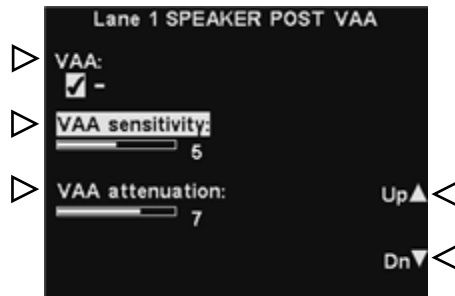

VAA ✓(on) or -(off):

To turn the VAA feature on or off, press the **VAA** button to select ✓(on) or -(off).

VAA Sensitivity Level:

This is the volume level of the order taker's voice required to activate the VAA circuit. During normal operation, the inbound audio level should be reduced when the Order Taker speaks to the customer, and should recover when the Order Taker stops speaking. If speaking to the customer does not automatically reduce the inbound level, press the **VAA sensitivity** button and then press the **Up** and **Dn** buttons to adjust sensitivity to the Order Taker's voice.

VAA Attenuation Level:

This is the amount that the inbound volume level is reduced when the Order Taker speaks to the customer. The attenuation level is factory set at 15dB, and should not require adjustment.

If the Order Taker cannot hear the inbound audio at all while speaking, the **VAA attenuation** can be adjusted to a lower level. To make this adjustment, press the **VAA attenuation** button and then press the **Up** and **Dn** buttons until the desired level is reached. If you do not want any attenuation, please just turn off VAA without adjusting this setting.

Restore Installer Settings

After the initial installer settings have been made, store personnel can make their own custom settings. After doing so, they can also return the base station to its original installer settings by pressing the **Restore installer settings** button on the **ADVANCED STORE SETTINGS** display, and then pressing the **Restore** button on the **RESTORE INSTALLER DEFAULTS** display.



Network Settings

If the base station is connected to a computer network, see [section 4.3.2](#) for Network adjustments.

AVC Setting

Press the **AVC** button to select ✓(on) or –(off) for AVC (Automatic Volume Control). When there is excessive outside noise, the level of the order taker's voice in the speaker will be adjusted up. When it is quiet in the drive-thru area, the level will be adjusted down.

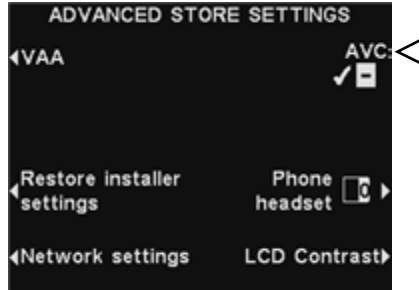

Phone Headset

If there is an HME Telephone Interface connected to your base station, you can assign one beltpac/headset to receive incoming telephone calls. To do this, press the **Phone Headset** button on the **STORE SETTINGS** display. On the SELECT PHONE HEADSET display, use the **Left** and **Right** buttons to move the highlight in the **Select phone headset** field, and then use the **Up** and **Dn** buttons to enter number of the beltpac/headset.

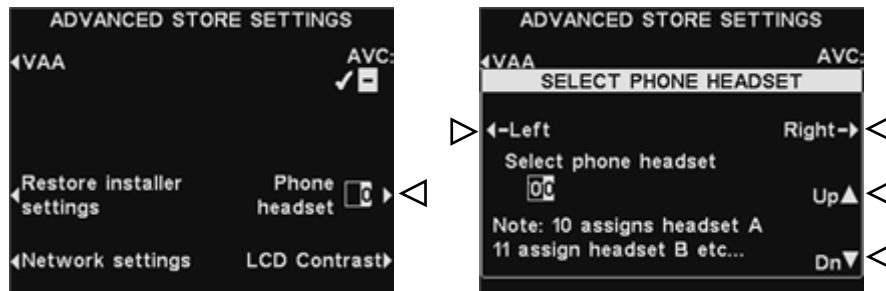

To save these settings, press the **Back** button.

LCD Contrast

To adjust the light/dark contrast of the base station display, press the **LCD Contrast** button on the **ADVANCED STORE SETTINGS** display, and then press the **Up** (lighter) and **Down** (darker) buttons to adjust the contrast. When you are finished, press the **Back** button to save the setting and return to the desired display.

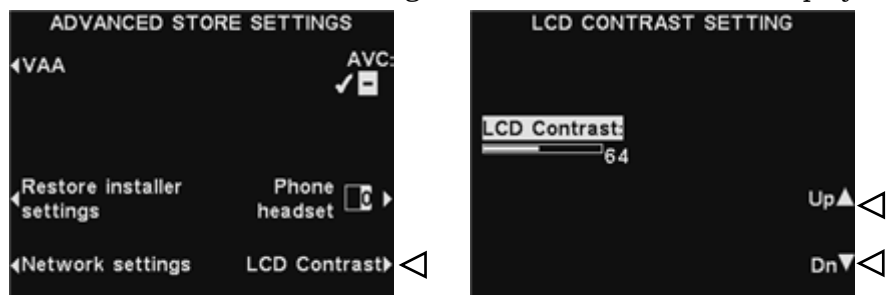

Note: This is a factory setting, and does not normally require adjustment during installation.

4.4.9 Diagnostics

Only press the **Diagnostics** button if you experience a problem with ion|IQ™ operation and have to call HME Technical Support. The Technical Support representative will guide you through the automated diagnostics. If this is necessary, select **Menu** on the base station **STATUS** display and then press the **More** button on the **MAIN MENU**. On the **ADVANCED MENU**, press the **Diagnostics** button, and then select the test requested by the Technical Support representative.



If requested, press the **More** button for additional advanced diagnostics.



4.4.10 Early Warning Setting

An external vehicle detector can be used with the ion|IQ™ to give a pre-warning signal when a vehicle enters the drive-thru area. To set up a pre-warning signal, first install the external vehicle detector at the desired detection point then connect its cable to the base station audio circuit board according to the appropriate [wiring diagram](#) in Figures 29 through 39.

4.5 PC Navigation

If your ion|IQ™ was set up to operate with a PC network, all of the same settings that can be made on the base station can also be made on your PC.

The following examples show you how to navigate through system settings as they appear on your PC screen.

The ion|IQ™ provides the ability to view and edit base station configuration settings. To open the ion|IQ™ on your PC, enter its IP Address in the address bar on your internet browser as shown below, and then press the **Enter** key on your keyboard.

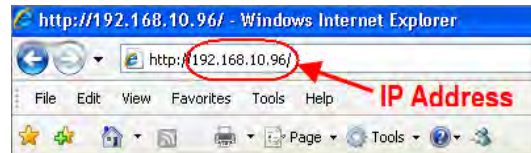

Note: To find the IP Address, go through the following display path on your base station: **STATUS > More**.

Select any category from the **Main Menu** that you would like to view or edit. Some topics will cause a **Secondary Menu** bar to appear, from which you can select a sub-topic.

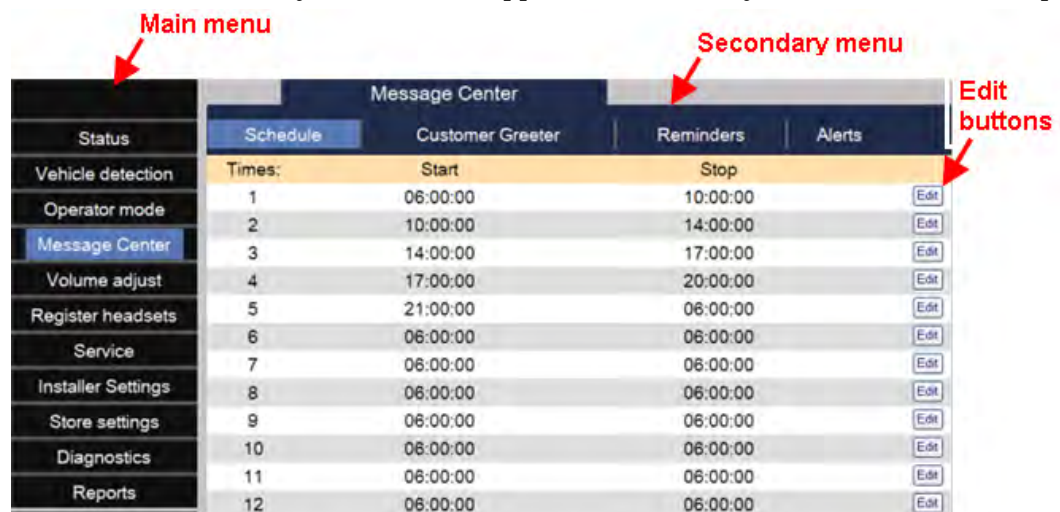

If you click your cursor on an **Edit** button, an edit bar will appear with setup choices. If you make any setup changes, you must click on the **Save** button to save your changes. If you do not want to save your changes, or do not make any changes, you can click on any other menu topic, or click on the back arrow at the top-left corner of the browser screen.



4.5.1 PC Reports

The ion|IQ™ is also able to generate the following reports to your PC.

The **Headset Statistics Report** includes a list of all headsets, with the following information:

- the last time/date each headset was used
- which messages are assigned to each headset
- which headset is assigned as the “phone” headset

The **Message Center Report** includes a list of all settings associated with each message that is ✓(on).

To view reports, select **Reports** from the Main menu.

5. *SYSTEM FUNCTIONAL CHECK*

<i>ACTION</i>	<i>RESULT</i>
Plug base station power adapter into electrical outlet.	System power is on. Base station lights are on.
Go outside (or have someone else go) to the speaker/microphone and do the following.	
Push COMMUNICATOR® button A1 or A2 and speak into headset microphone.	Audio should be heard at outside speaker.
Release button A1/A2. On the base station MAIN MENU display, press the Vehicle Detection button, and then press the Mode button to select OVERRIDE. Tap on outside microphone.	Vehicle present tone should be heard in headset earpiece, followed by inbound audio. If this does not happen, there is a wiring problem.

6. ION/IQ™ ROUTINE OPERATION

The ion|IQ™ can be operated in Hands-Free (HF), Auto-Hands-Free (AHF) or Push-To-Talk (PTT) modes.

A full-duplex system supports HF, AHF and PTT operation. In HF and AHF operation, communication can be transmitted and received at the same time, as in a normal telephone conversation. In the AHF mode, transmission and reception are activated automatically when a customer drives into the drive-thru lane. In the HF mode, transmission and reception are activated by touching and releasing the A1 or A2 button on the Communicator. In the PTT mode, the A1 or A2 button must be pressed and held while the operator is talking to the customer. A half-duplex system only supports the PTT mode, and the customer's voice will not be heard while the operator is pressing the A1 or A2 button.

In single lane operations, when a customer arrives in the drive-thru lane, you will hear a single beep in the headset.

In dual-lane operations, when a customer arrives in a drive-thru lane, you will hear one beep in the headset for Lane 1 and two beeps for Lane 2.

In dual-lane operation, if you are communicating with a customer in one lane when another customer arrives in the other lane, you will hear a beep in the headset.

When the customer leaves the speaker post in the lane you are connected to, the same beep will repeat in the headset every four seconds until you touch the A1 or A2 button to communicate with the customer in the other lane.

Note: In dual-lane operations, if you have a Mode Switch and it is set to "DEDICATED," you will only hear beeps in the headset when a customer arrives in the lane you are operating.

6.1 Changing COMMUNICATOR® Languages

To change the language of the cues heard in the Communicator, from English to Spanish/French and back to English, with the Communicator power off, press and hold the volume-down ▼ button and the A1 button while you press the power PWR button. The language of the cues heard in the headset will change when the power goes on.

6.2 Obtaining COMMUNICATOR® Status

To obtain Communicator status, with the Communicator power off, press and hold the volume-down ▼ button and the A2 button while you press the power PWR button. You will hear the status message in the headset earpiece when the power goes on.

6.3 Single-Lane Operation (one speaker post in one lane)

Hands-Free (HF) Mode:

- With the power off, press and hold the volume-up ▲ and B buttons while you press and release the PWR button to turn the COMMUNICATOR® on in the HF mode. The Communicator will remember this setting.
- As a customer enters the drive-thru lane, you will hear an alert tone (single beep) in the headset, and you will be able to hear the customer at the speaker post or menu board.
- Use the volume-up ▲ and down ▼ buttons to adjust the customer's voice level in the headset if necessary.
- Touch and release the A1 or A2 button to speak and listen to the customer.
- Touch and release the A1, A2 or B button to end communication with the customer.
- Touch and release the A1 or A2 button if you want to speak to the customer again.
- If a customer drives away from the speaker post or menu board, the Communicator will stop transmitting.

Auto Hands-Free (AHF) Mode:

Only one Communicator operator at a time can use the auto hands-free feature. If a Communicator is turned off while in the AHF mode, it will automatically be reset to its previous operating mode.

- With the power off, press and hold the volume-up ▲ and A1 buttons while you press and release the PWR button to turn the Communicator on in the AHF mode.
- As a customer enters the drive-thru lane, you will hear an alert tone (single beep) in the headset, and you will be able to hear the customer at the speaker post or menu board.
- Use the volume-up ▲ and down ▼ buttons to adjust the customer's voice level in the headset if necessary.
- Speak and listen to the customer without pressing any buttons.
- Touch and release the A1, A2 or B button to end communication with the customer.
- Touch and release the A1 or A2 button if you want to speak to the customer again.
- If a customer drives away from the speaker post or menu board, the Communicator will stop transmitting.

Push-To-Talk (PTT) Mode:

- With the power off, press and hold the volume-down ▼ and B buttons while you press and release the PWR button to turn the Communicator on in the PTT mode. The Communicator will remember this setting.
- As a customer enters the drive-thru lane, you will hear an alert tone (single beep) in the headset, and you will be able to hear the customer at the speaker post or menu board.
- Use the volume-up ▲ and down ▼ buttons to adjust the customer's voice level in the headset if necessary.
- Touch and hold the A1 or A2 button to speak to the customer. Release to stop speaking to the customer (full duplex) or to listen to the customer (half duplex).

6.4 Dual-Lane Operation (two lanes with one speaker post in each lane)

Hands-Free (HF) Mode:

- With the COMMUNICATOR® power off, press and hold the volume-up ▲ and B buttons while you press and release the PWR button to turn the Communicator on in the HF mode. The Communicator will remember this setting.
- As a customer enters a drive-thru lane, you will hear an alert tone in the headset (single beep for Lane 1, double beep for Lane 2), and you will be able to hear the customer at the speaker post or menu board if that lane is selected.
- Use the volume-up ▲ and down ▼ buttons to adjust the customer's voice level in the headset if necessary.
- Touch and release the A1 button for Lane 1 or A2 for Lane 2, to speak and listen to the customer.
- Touch and release the A1, A2 (depending on lane) or B button to end communication with the customer.
- Touch and release the A1 button for Lane 1 or A2 for Lane 2, to speak to the customer again.
- To change lanes, touch and release the opposite A button.
- If a customer drives away from the speaker post or menu board, the Communicator will stop transmitting.

Auto Hands-Free (AHF) Mode:

Only one Communicator operator at a time, in each lane, can use the AHF feature. If an operator attempts to configure another Communicator, "System busy" will be heard in his/her headset. Changing lanes is not possible in the AHF mode. If you turn a Communicator off in the AHF mode, it will reset to its previous operating mode.

- For Lane 1 operation, with the power off, press and hold the volume-up ▲ and A1 buttons while you press and release the PWR button to turn the Communicator on in the AHF mode.
- For Lane 2 operation, with the power off, press and hold the volume-up ▲ and A2 buttons while you press and release the PWR button to turn the Communicator on in the AHF mode.
- As a customer enters a drive-thru lane, you will hear an alert tone in the headset (single beep for Lane 1, double beep for Lane 2), and you will be able to hear the customer at the speaker post or menu board if that lane is selected.
- Use the volume-up ▲ and down ▼ buttons to adjust the customer's voice level in the headset if necessary.
- Speak and listen to the customer without pressing any buttons.
- Touch and release the A1, A2 (depending on lane) or B button to end communication with the customer.
- Touch and release the A1 button for Lane 1 or A2 for Lane 2, to speak to the customer again.
- If a customer drives away from the speaker post or menu board, the Communicator will stop transmitting.

Push-To-Talk (PTT) Mode:

- With the Communicator power off, press and hold the volume-down ▼ and B buttons while you press and release the PWR button to turn the Communicator on in the PTT mode. The Communicator will remember this setting.
- As a customer enters a drive-thru lane, you will hear an alert tone in the headset (single beep for Lane 1, double beep for Lane 2), and you will be able to hear the customer at the speaker post or menu board if that lane is selected.
- Use the volume-up ▲ and down ▼ buttons to adjust the customer's voice level in the headset if necessary.
- Touch and hold the A1 button to speak to a customer in Lane 1, or A2 to speak to a customer in Lane 2. Release to stop speaking to the customer (full duplex) or to listen to the customer (half duplex).

6.5 Tandem Operation (two speaker posts in one lane)

In Tandem operation, customers at Order Point #1 are served by Order Taker #1, and customers at Order Point #2 are served by Order Taker #2. If a customer arrives at Order Point #2 when there is no customer at Order Point #1, a message will be played automatically from Speaker Post or Menu Board #2 saying “Please pull forward.” When a customer arrives at Order Point #1, Order Taker #1 will be alerted. If a customer arrives at Order Point #2 when there is already a customer at Order Point #1, Order Taker #2 will be alerted.

Note: If you want to change the pre-recorded “Please pull forward” message, see [Message Center](#) settings.

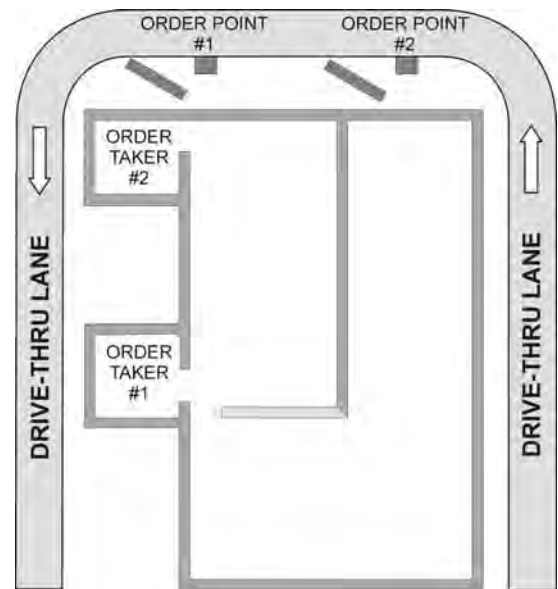

Figure 25. Typical tandem drive-thru layout

CAUTION: *In tandem operation, if Order Taker #2’s Communicator is set in the Auto Hands-Free mode, the “Please pull forward” message will not be played at Order Point #2. If necessary, Order Taker #2 will have to ask the customer at Order Point #2 to pull forward.*

Hands-Free (HF) Mode (Either Order Taker):

- With the COMMUNICATOR® power off, press and hold the volume-up ▲ and B buttons while you press and release the PWR button to turn the Communicator on in the HF mode. The Communicator will remember this setting.
- As a customer approaches Order Point #1, Order Taker #1 will hear an alert tone in the headset, and will be able to hear the customer at speaker post or menu board #1.
- If a customer approaches Order Point #2 when there is already another customer at Order Point #1, Order Taker #2 will hear an alert tone in the headset, and will be able to hear the customer at speaker post or menu board #2.
- Use the volume-up ▲ and down ▼ buttons to adjust the customer’s voice level in the headset if necessary.
- Order Taker #1, touch and release the A1 button to speak and listen to the customer at Order Point #1.
- Order Taker #2, touch and release the A2 button to speak and listen to the customer at Order Point #2.
- Touch and release the A1/A2 (depending on which Order Taker) or B button to end communication with the customer.
- Touch and release the A1/A2 (depending on which Order Taker) to speak to the customer again.
- If a customer drives away from the speaker post or menu board, the Communicator will stop transmitting.

Auto Hands-Free (AHF) Mode (Only Order Taker #1):

- Order Taker #1 only, with the power off, press and hold the volume-up ▲ and A1 button while you press and release the PWR button to turn the Communicator on in the AHF mode.
- As a customer approaches Order Point #1, you will hear an alert tone in the headset, and you will be able to hear the customer at speaker post or menu board #1.
- Use the volume-up ▲ and down ▼ buttons to adjust the customer's voice level in the headset if necessary.
- Speak and listen to the customer without pressing any buttons.
- Touch and release the A1 or B button to end communication with the customer.
- Touch and release the A1 button to speak to the customer again.
- If a customer drives away from the speaker post or menu board, the Communicator will stop transmitting.

Push-To-Talk (PTT) Mode (Either Order Taker):

- With the Communicator power off, press and hold the volume-down ▼ and B buttons while you press and release the PWR button to turn the Communicator on in the PTT mode. The Communicator will remember this setting.
- As a customer approaches Order Point #1, Order Taker #1 will hear an alert tone in the headset, and will be able to hear the customer at speaker post or menu board #1.
- If a customer approaches Order Point #2 when there is already another customer at Order Point #1, Order Taker #2 will hear an alert tone in his/her headset, and will be able to hear the customer at speaker post or menu board #2.
- Use the volume-up ▲ and down ▼ buttons to adjust the customer's voice level in the headset if necessary.
- Touch and hold the A1 button to speak to a customer at Order Point #1, or A2 to speak to a customer at Order Point #2. Release to stop speaking to the customer (full duplex) or to listen to the customer (half duplex).

6.6 Internal Communication

To communicate internally with other COMMUNICATOR® operators, press and hold the B button while talking. Release when finished. In single-lane operations, up to four Communicator operators can have conference-call type communication by all pressing and holding their B button. They will hear each other without interference. In dual-lane operation, if the system was set up for "Split-B," internal communication will be heard only by Communicator operators in their lane. If the system was not set up for Split-B operation, all internal communication will be heard by Communicator operators in both lanes. In dual-lane operation, up to three Communicator operators can have conference-call type communication by all pressing and holding their B buttons. They will hear each other without interference. If a car arrives in a lane while internal communication is taking place, priority will be given to the respective A channel for customer communication, which will reduce the number of internal communication channels available.

6.7 Speed-Team Operation

Speed team operation is used during high-volume times. An order taker wearing a Communicator relays orders from outside into the store, using button A1, A2 or B.

Note: Speed teams are only used in single or dual-lane drive-thrus, not in tandem drive-thrus.

CAUTION: *With Speed Team ✓(on), many base station functions will be disabled. Vehicle arrival tones and the customer's voice will not be heard during Speed Team operation. For normal order taking, the Speed Team setting should be -(off).*

To start speed-team operation, you must press the **Menu** button on the base station **STATUS** display, and then press the **Operator mode** button on the **MAIN MENU** display. On the **OPERATOR MODE** display, press the **Turn Speed Team** button to select ✓(on). To change back to normal operation, return to the **OPERATOR MODE** display and press the **Turn Speed Team** button to select -(off).

Select **Ext** only if speed team will be activated from a remote switch.

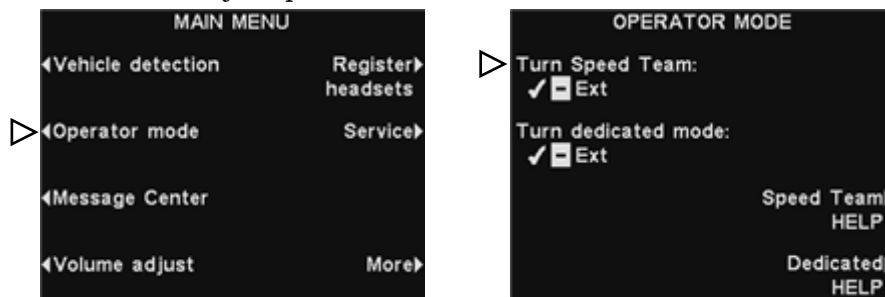

6.8 Wired Backup System

In order to use a wired backup system, there must be a Switcher Board (optional) in the base station. Open the base station, and look for the board shown in Figure 26. If there is no Switcher Board, a wired backup system cannot be used. If there is a Switcher Board, place the S2 switch in the IN position to use the wired backup system. When using the ion|IQ™, leave the S2 switch in the OUT position.

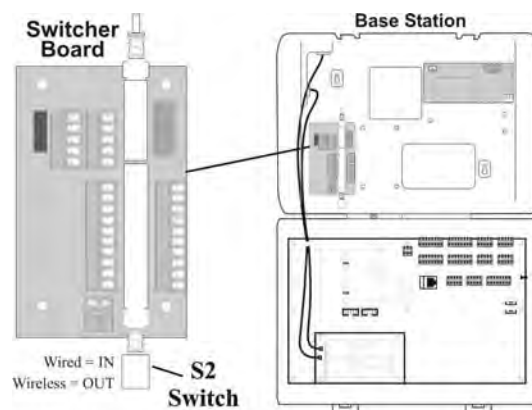

Figure 26. S2 switch on Switcher Board

6.9 Message Center Operation

To record messages and set up times and locations for them to be played, refer to [section 4.4.3](#), under Operator Settings.

7. IN CASE OF PROBLEMS

PROBLEM	PROBABLE CAUSE	SOLUTION
“Battery failed” is heard in headset when COMMUNICATOR® PWR button is pressed.	Battery may be defective.	Replace battery. Call HME.*
	Headset battery contacts may be dirty.	Clean headset battery contacts with alcohol.
“Headset failed” is heard in headset when Communicator PWR button is pressed.	Headset may be defective.	Use another headset. Call HME.*
	Headset battery contacts may be dirty.	Clean headset battery contacts with alcohol.
You hear your echo in headset earpiece when you speak into Communicator microphone.	Outside speaker and microphone may not be properly installed.	Be sure speaker and microphone are isolated from each other, and are tightly mounted with enough foam packed around each of them to absorb vibrations.
	Outbound and/or inbound audio level may be set too high.	Set outbound audio level just high enough to be heard by customers. Lower inbound audio to comfortable level.
	VAA controls may need to be adjusted.	Adjust VAA Level control to reduce inbound audio level when you are speaking into the headset microphone.
		Adjust VAA attenuation level to reduce inbound audio level when you are speaking into the headset microphone. NOTE: If the inbound level is too low, you will not hear the customer.
No sound is heard in Communicator headset when you press button A and speak into microphone.	Power may be off at base station.	Be sure HME logo and other lights on base station are lit. Check circuit breaker for building.
	Power supply in base station may not be working.	Be certain power adapter is plugged into AC electrical outlet, and is connected to J3 on base station audio circuit board.
	Communicator power may not be on.	Press PWR button on Communicator. Be certain power light goes on and switches from red to green.
	Volume may not be set correctly.	Adjust volume with Volume-up and down buttons.
	Battery may be low or defective.	Check Communicator Power light. If not lit, replace battery.
	Headset may be defective.	Use another headset. Call HME.*
	Communicator may not be registered.	Register Communicator.
Channel A or B is not working.	Communicator power may not be on.	Press PWR button on Communicator. Be certain power light goes on and switches from red to green.
	Battery may be low or defective.	Check Power light. If not lit, replace battery.
	A1/A2 or B1/B2 light on base station does not light when button A or B on Communicator is pressed.	Use another Communicator. Call HME.*
	Communicator may not be registered.	Register Communicator.
Outbound sound is too low.	Outbound volume may be set too low for environment.	Adjust outside speaker volume level.
No outbound sound; Customer cannot hear anything.	System may be set for speed team.	Check speed-team setting.
	There may be loose wires on outside speaker or base station circuit board.	Check vehicle present light (car) on base station. Check outside speaker wire connections on J6 or J14 in base station and at outside speaker.
	Defective speaker or base station.	Call HME.*
Customer cannot be heard in push-to-talk (PTT) operation.	System may be set for speed team.	Check speed-team setting.
	Base station may be set for wrong drive-thru mode (full or half-duplex).	Check drive-thru mode setting.

PROBLEM	PROBABLE CAUSE	SOLUTION
Only intermittent voice can be heard in headsets.	Transmitter antenna connectors on base station transceiver circuit board may be loose or damaged.	Be certain antennas are screwed securely onto base station. Check transmitter antenna cable connections at ANT1 and ANT2 on left side of transceiver circuit board. Call HME.*
	Circuit board may be defective.	Call HME.*
	VAA level is too sensitive.	Reduce VAA level.
Personnel hear customers in ceiling speaker or headsets, but cannot hear each other.	Circuit board may be defective.	Check to see if A1/A2 and B1/B2 lights on base station are lit when buttons are pressed. Call HME.*
	Defective COMMUNICATOR®.	Use another Communicator. Call HME.*
No tone or sound is heard in ceiling speaker or headsets when vehicle enters drive-thru lane.	Power interruption may have caused vehicle detection circuit to be out of balance.	When no vehicle is in the drive-thru lane, reset vehicle detector.
	System may be set for speed team.	Be certain speed-team setting is not set to ON.
	Connector may be loose.	Check all connectors in base station. Call HME.*
Personnel cannot hear customers in ceiling speaker or headsets.	There may be loose wires on base station circuit board.	Check all connections on base station circuit boards.
	System may be set for speed team.	Be certain speed-team setting is not set to ON.
	Outside speaker, audio circuit board or vehicle detector board failed.	Call HME.*
	VAA attenuation set too high	Reduce attenuation.
Headset has intermittent sound.	Battery may be low.	Replace battery.
	Headset may be defective.	Use another headset. Call HME.*
There is still sound in headset after all customers have been served.	Base station may be set to override position.	On the VEHICLE DETECTION menu, be certain the Mode setting is in the Normal position.
	Vehicle detector may be locked up.	On the VEHICLE DETECTION menu, select Reset Veh Detect.
Battery charger is not working.	Charger may not be plugged in.	Be certain charger is plugged in. If it still is not working, call HME.*
Communicator “Registration failed” message heard in headset. Lights stay red.	Base station power not on.	Be sure HME logo and other lights on base station are lit. If no light is lit, be certain power adapter is plugged into electrical outlet, and is connected to J3 on base station audio circuit board.
	Registration button not pushed.	Repeat registration procedure. Call HME.*

* For assistance, call HME at 1-800-848-4468, or Fax 858-552-0172.

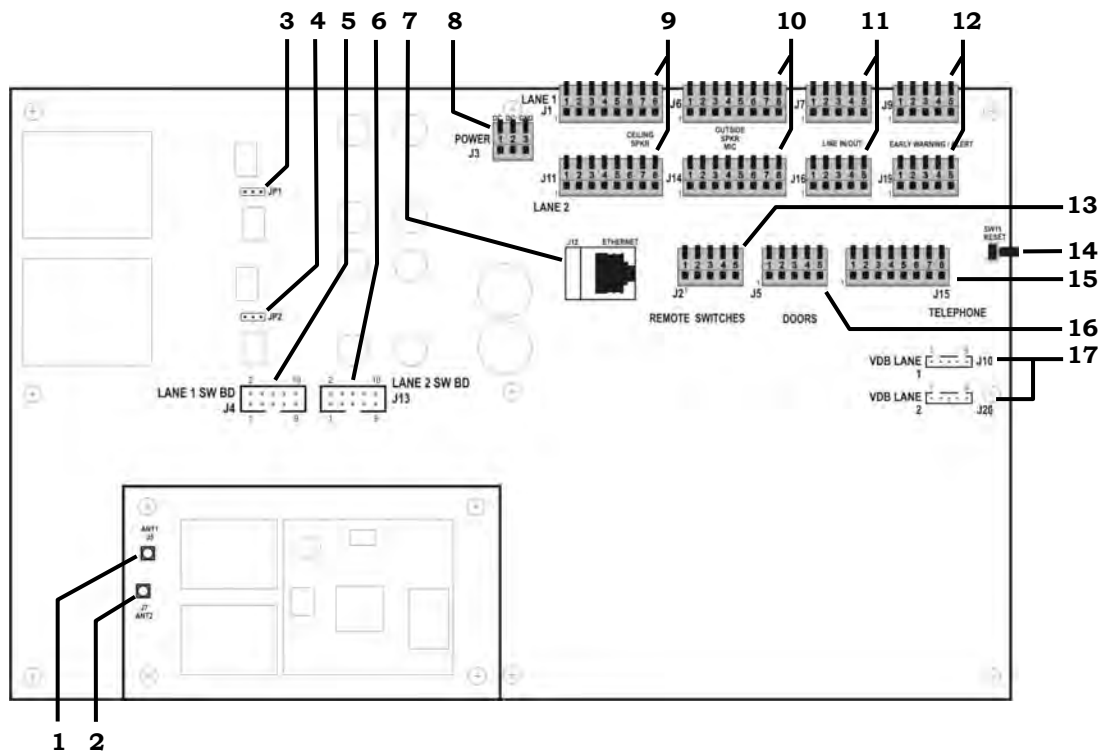

Figure 27. Base station internal connectors and controls

1. ANT1 antenna connector
2. ANT2 antenna connector
3. Jumper, microphone load, JP1-Lane 1
4. Jumper, microphone load, JP2-Lane 2
5. Switcher board connectors, J4-Lane 1
6. Switcher board connectors, J13-Lane 2
7. Ethernet connector, J12
8. Power connector, J3
9. Ceiling speaker connector, J1-Lane 1, J11-Lane 2
10. Outside speaker/microphone connector, J6-Lane 1, J14-Lane 2
11. Line in/out connector, J7-Lane 1, J16-Lane 2
12. Early warning/alert connector, J9-Lane 1, J19-Lane 2
13. Remote switch connector, J2
14. Reset switch
15. Telephone connector, J15
16. Doors connector for Alert message activation, J5
17. Vehicle detector board (VDB) connector, J10-Lane 1, J20-Lane 2

8. TO SET BASE STATION FOR SPANISH OR FRENCH LANGUAGE OPERATION

If the base station is returned to its factory default settings, it will be set for English language operation. To change the language to Spanish or French, make the following selections on the base station display.

Press the buttons indicated by arrows in the order of the numbered displays.

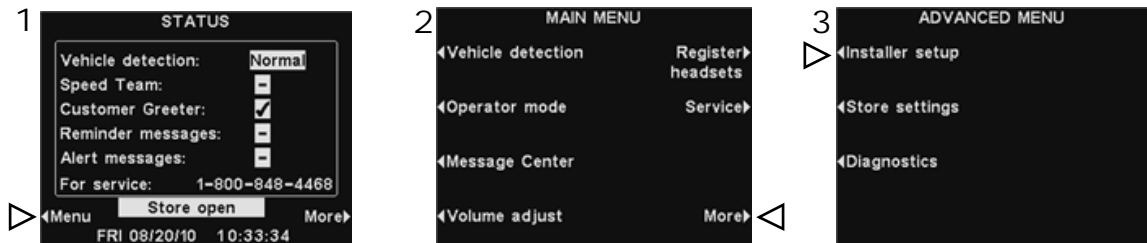

On the **ENTER INSTALLER PASSWORD** display – enter the first character of the 4-digit password in the highlighted box in the **Enter Password** field by pressing the **Up** button to enter alphabetic characters, or the **Dn** (down) button to enter numbers. Press the **Right** button to move the highlighted box to the next position to the right. Repeat this procedure until all 4 digits of the password are entered, and then press the **Continue** button to access the **INSTALLER SETUP** display.

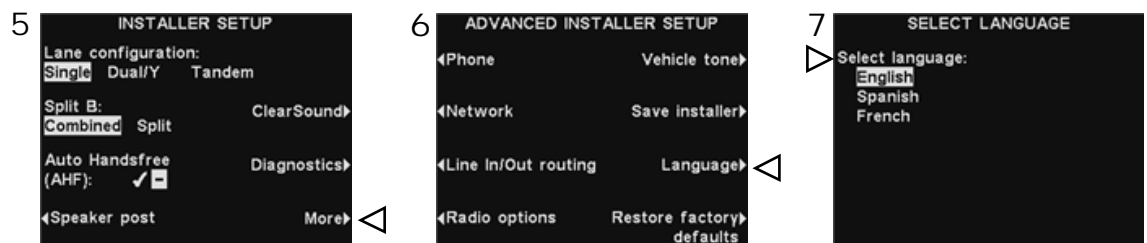

After selecting the language, press the **Back** button to save the setting. The base station will automatically be reset to its previous operating mode.

9. EQUIPMENT SPECIFICATIONS

Base Station

Voltage input	24VDC ±2.5V
AC current input	2.5A maximum
Audio distortion	5% maximum level
Outside speaker output	3 watts RMS into 8 ohms
Ceiling speaker power	3 watts RMS into 8 ohms
TX/RX frequency	2400MHz – 2483.5MHz
Dimensions	9.75”H x 13”W x 3.5”D (248 mm x 330 mm x 89 mm)
Weight	3.25 lbs (1.47 kg) maximum

COM6000BP Belt-Pac COMMUNICATOR®

Battery type	3.6V Lithium ion
Battery life	18 - 20 hours (typical)
RF frequency	2400MHz – 2483.5MHz
Weight	5.1 oz (.133 kg) with battery

Odyssey IQ Headset COMMUNICATOR®

Battery type	3.6V Lithium ion
Battery life	18 - 20 hours (typical)
RF frequency	2400MHz – 2483.5MHz
Weight	5.7 oz (.16 kg) with battery

AC40 Battery Charger

Voltage input	16.5VAC
Charging time	2 hrs maximum
Dimensions	7.6” x 4.6” x 2.6” (193mm x 117mm x 66mm)
Weight	1.5 lb (.68 kg)

10. BLOCK DIAGRAM

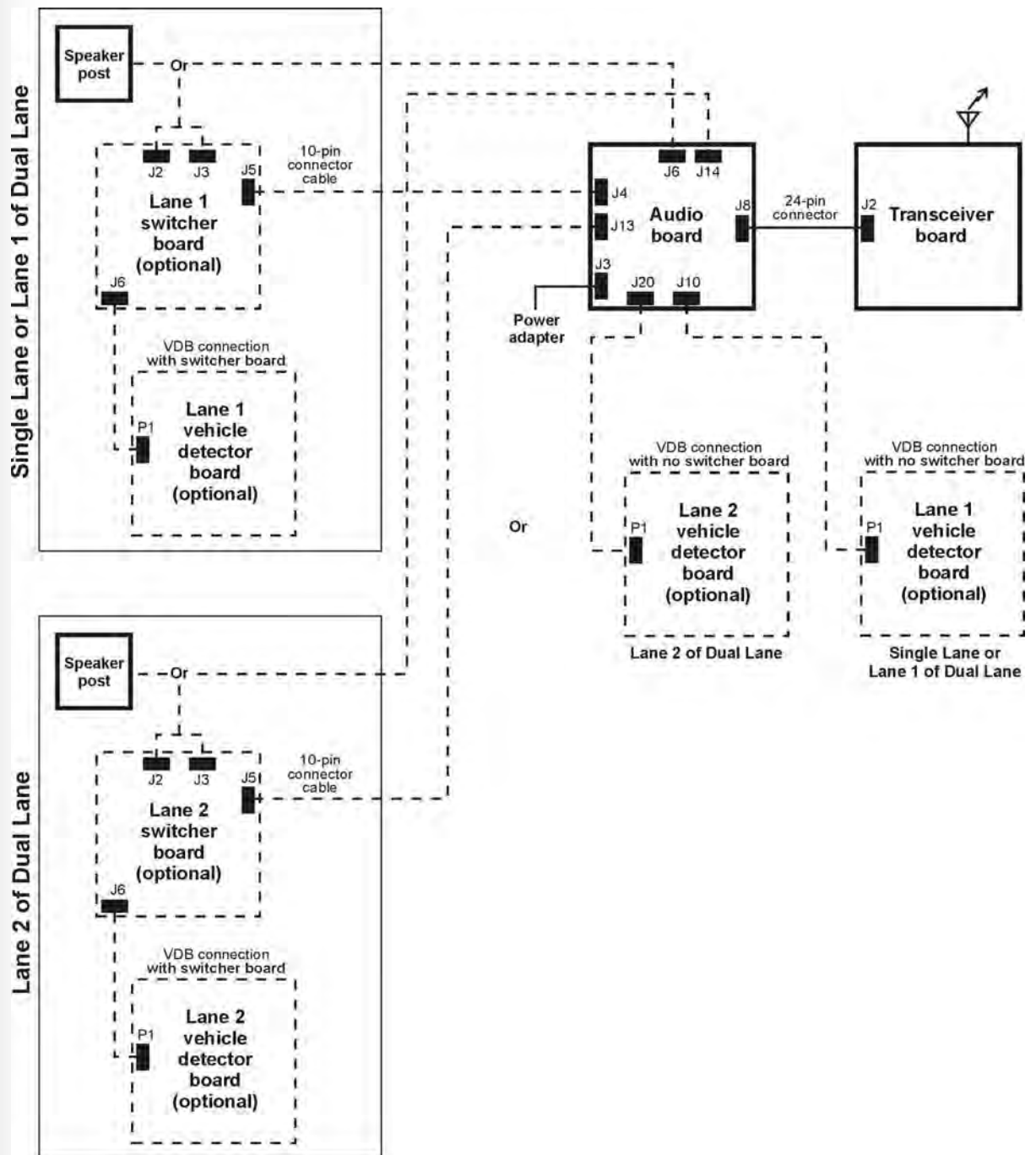

Figure 28. Typical ion|IQ™ Base Station block diagram

11. BASE INTERFACE DESCRIPTION

11.1 Audio Circuit Board

J1 – Ceiling Speaker In/Out, Lane 1

J1,1	Ground
J1,2	/A1 Talk
J1,3	Relay 1 Common
J1,4	Relay 1 Normally Open
J1,5	Relay 1 Normally Closed
J1,6	Ceiling speaker +
J1,7	Ceiling speaker –
J1,8	Ground

J2 – Remote

J2,1	Ground
J2,2	/Remote speed team
J2,3	Ground
J2,4	/Operator
J2,5	Not used

J3 – Power

J3,1	+24VDC / 16VAC power input
J3,2	–24VDC / 16VAC power input
J3,3	Ground (For DC only)

J4 – Interface w/ Switcher Board, Lane 1

J4,1	Microphone 1
J4,2	Microphone 2
J4,3	Ground
J4,4	+12VDC
J4,5	Not used
J4,6	Negative vehicle detect input
J4,7	Vehicle detector power (12V)
J4,8	Not used
J4,9	Outside speaker –
J4,10	Outside speaker +

J5 – Door Inputs

J5,1	Door 1
J5,2	Door 2
J5,3	Door 3
J5,4	Door 4
J5,5	Ground

J6 – Interface w/o Switcher Board, Lane 1

J6,1	Microphone 1
J6,2	Microphone 2
J6,3	Ground
J6,4	+12VDC
J6,5	Negative vehicle detect input
J6,6	Not used
J6,7	Outside speaker –
J6,8	Outside speaker +

J7 – Line In/Out, Lane 1

J7,1	Line out
J7,2	Ground
J7,3	Line in
J7,4	Ground
J7,5	Not used

J9 – Early Warning / Alert, Lane 1

J9,1	Early warning
J9,2	Ground
J9,3	Not used
J9,4	Ground
J9,5	Alert in

J10 – Vehicle Detector Board Interface, Lane 1 (Primary)

J10,1	Negative vehicle detect signal
J10,2	+12V Vehicle detector power
J10,3	Ground
J10,4	Not used
J10,5	Not used

J11 – Ceiling Speaker In/Out, Lane 2

J11,1	Ground
J11,2	/A1 Talk
J11,3	Relay 2 Common
J11,4	Relay 2 Normally Open
J11,5	Relay 2 Normally Closed
J11,6	Ceiling speaker +
J11,7	Ceiling speaker –
J11,8	Ground

J13 – Interface w/ Switcher Board, Lane 2

J13,1	Microphone 1
J13,2	Microphone 2
J13,3	Ground
J13,4	+12VDC
J13,5	Not used
J13,6	Negative vehicle detect input
J13,7	Vehicle detector power (12V)
J13,8	Not used
J13,9	Outside speaker –
J13,10	Outside speaker +

J14 – Interface w/o Switcher Board, Lane 2

J14,1	Microphone 1
J14,2	Microphone 2
J14,3	Ground
J14,4	+12VDC
J14,5	Negative vehicle detect input
J14,6	Not used
J14,7	Outside speaker –
J14,8	Outside speaker +

J15 – Telephone Interface

J15,1 Telephone audio into base
 J15,2 12V
 J15,3 /A2 talk
 J15,4 /B2 talk
 J15,5 Car 2
 J15,6 Vehicle detect in
 J15,7 Ground
 J15,8 Telephone audio out to phone line

J16 – Line In/Out, Lane 2

J16,1 Line out
 J16,2 Ground
 J16,3 Line in
 J16,4 Ground
 J16,5 Not used

J19 – Early Warning / Alert, Lane 2

J19,1 Early warning
 J19,2 Ground
 J19,3 Not used
 J19,4 Ground
 J19,5 Alert in

J20 – Vehicle Detector Board Interface, Lane 2 (Secondary)

J20,1 Negative vehicle detect signal
 J20,2 +12V Vehicle detector power
 J20,3 Ground
 J20,4 Not used
 J20,5 Not used

11.2 Switcher Circuit Board

J1 – DM1 Interconnect

J1,1 Microphone in
 J1,2 Microphone in
 J1,3 Ground
 J1,4 +12VDC
 J1,5 Not used

J2 – Menu Board Interconnect

J2,1 Speaker/microphone in/out
 J2,2 Speaker/microphone in/out
 J2,3 Shield
 J2,4 Speaker out
 J2,5 Speaker out

J3 – Detector/Timer Interconnect

J3,1 Loop
 J3,2 Loop
 J3,3 Positive vehicle detection signal (in)
 J3,4 Ground
 J3,5 Negative vehicle detection signal (in)
 J3,6 Greet
 J3,7 Greet
 J3,8 Negative vehicle detection signal (out)
 J3,9 Ground
 J3,10 Positive vehicle detection signal (out)

J4 – Backup System Interconnect

J4,1 Loop
 J4,2 Loop
 J4,3 Negative vehicle detection signal (out)
 J4,4 Ground

J4,5 Positive vehicle detection signal (out)

J4,6 Not used
 J4,7 Speaker/microphone in/out
 J4,8 Speaker/microphone in/out
 J4,9 +12V to +48V in
 J4,10 +12V to +48V in

J5 – Audio Board Interconnect

J5,1 Microphone 1
 J5,2 Microphone 2
 J5,3 Ground
 J5,4 +12VDC
 J5,5 Positive vehicle detector input (not used)
 J5,6 Negative vehicle detector input
 J5,7 Vehicle detector power
 J5,8 Not used
 J5,9 Outside speaker –
 J5,10 Outside speaker +

J6 – Vehicle Detector Board Interconnect

J6,1 Vehicle detector signal
 J6,2 Vehicle detector power (12V)
 J6,3 Ground
 J6,4 Not used
 J6,5 Not used

TB1 – Connector for Internal Detector

1 Loop in
 2 Loop in

11.3 Vehicle Detector Circuit Board (Optional)

P1 – Audio Board Interface Cable Connector

P1,1 Signal
 P1,2 Power
 P1,3 Ground

TB1 – Vehicle Detector Loop Connector

12. WIRING DIAGRAMS

Full-Duplex Drive-Thru System with VDB but no Switcher Board

Page 79, [Figure 29](#) — (Connections for Lane 1 or Single Lane)

Page 80, [Figure 30](#) — (Connections for Lane 2 of Dual/Y-Lane or Tandem)

Full-Duplex Drive-Thru System with VDB, Switcher Board and IC300 Intercom

Page 81, [Figure 31](#) — (Connections for Lane 1 or Single Lane)

Page 82, [Figure 32](#) — (Connections for Lane 2 of Dual/Y-Lane or Tandem)

Full-Duplex Drive-Thru System with VDB, Switcher Board and Microphone

Page 83, [Figure 33](#) — (Connections for Lane 1 or Single Lane)

Page 84, [Figure 34](#) — (Connections for Lane 2 of Dual/Y-Lane or Tandem)

Half-Duplex Drive-Thru System with VDB but no Switcher Board

Page 85, [Figure 35](#) — (Connections for Lane 1 or Single Lane)

Page 86, [Figure 36](#) — (Connections for Lane 2 of Dual/Y-Lane or Tandem)

Half-Duplex Drive-Thru System with VDB and Switcher Board

Page 87, [Figure 37](#) — (Connections for Lane 1 or Single Lane)

Page 88, [Figure 38](#) — (Connections for Lane 2 of Dual/Y-Lane or Tandem)

Page 89, [Figure 39](#) — **Optional Equipment Connections**

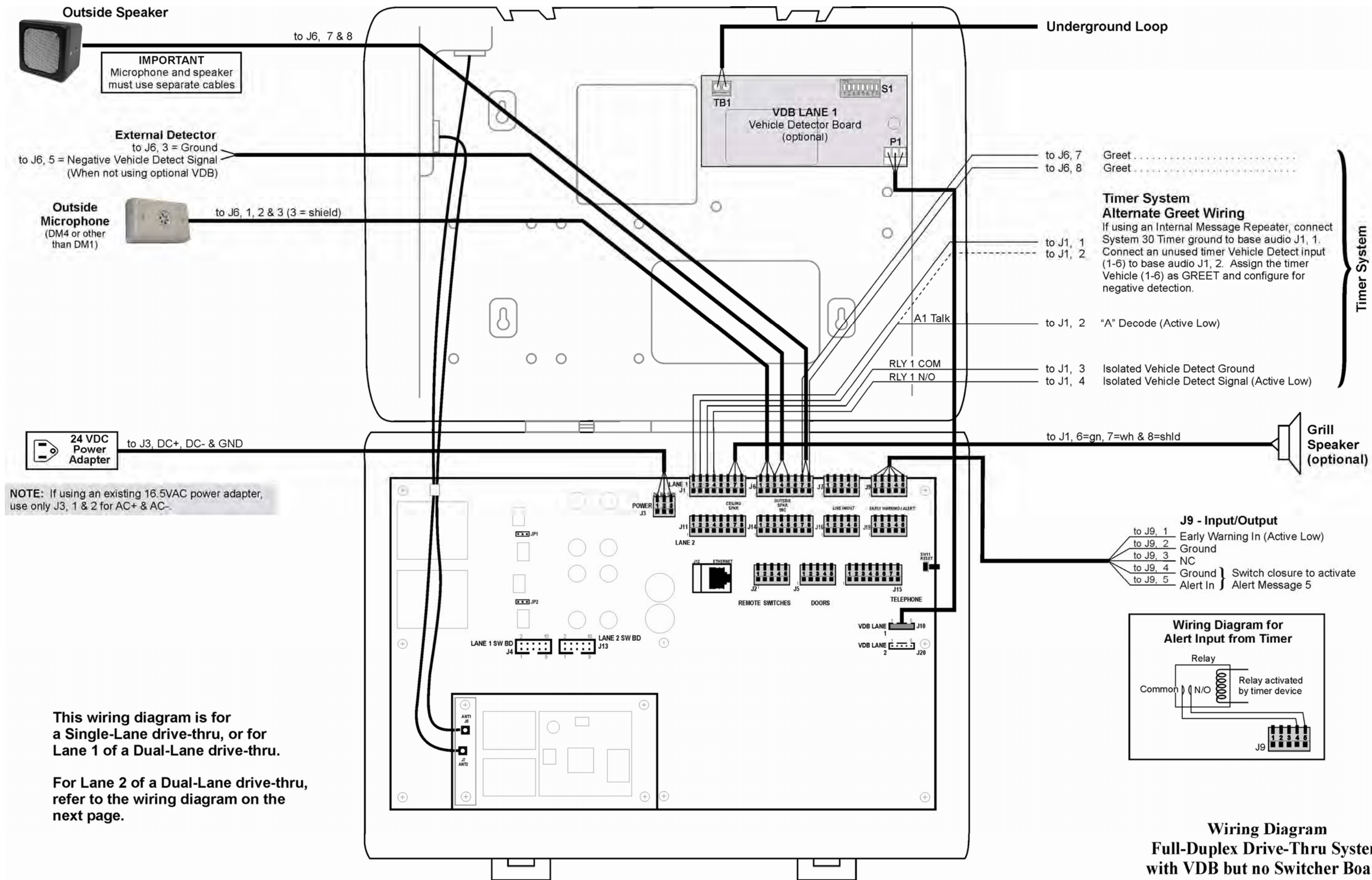

This wiring diagram is for a Single-Lane drive-thru, or for Lane 1 of a Dual-Lane drive-thru.

For Lane 2 of a Dual-Lane drive-thru, refer to the wiring diagram on the next page.

Figure 29.

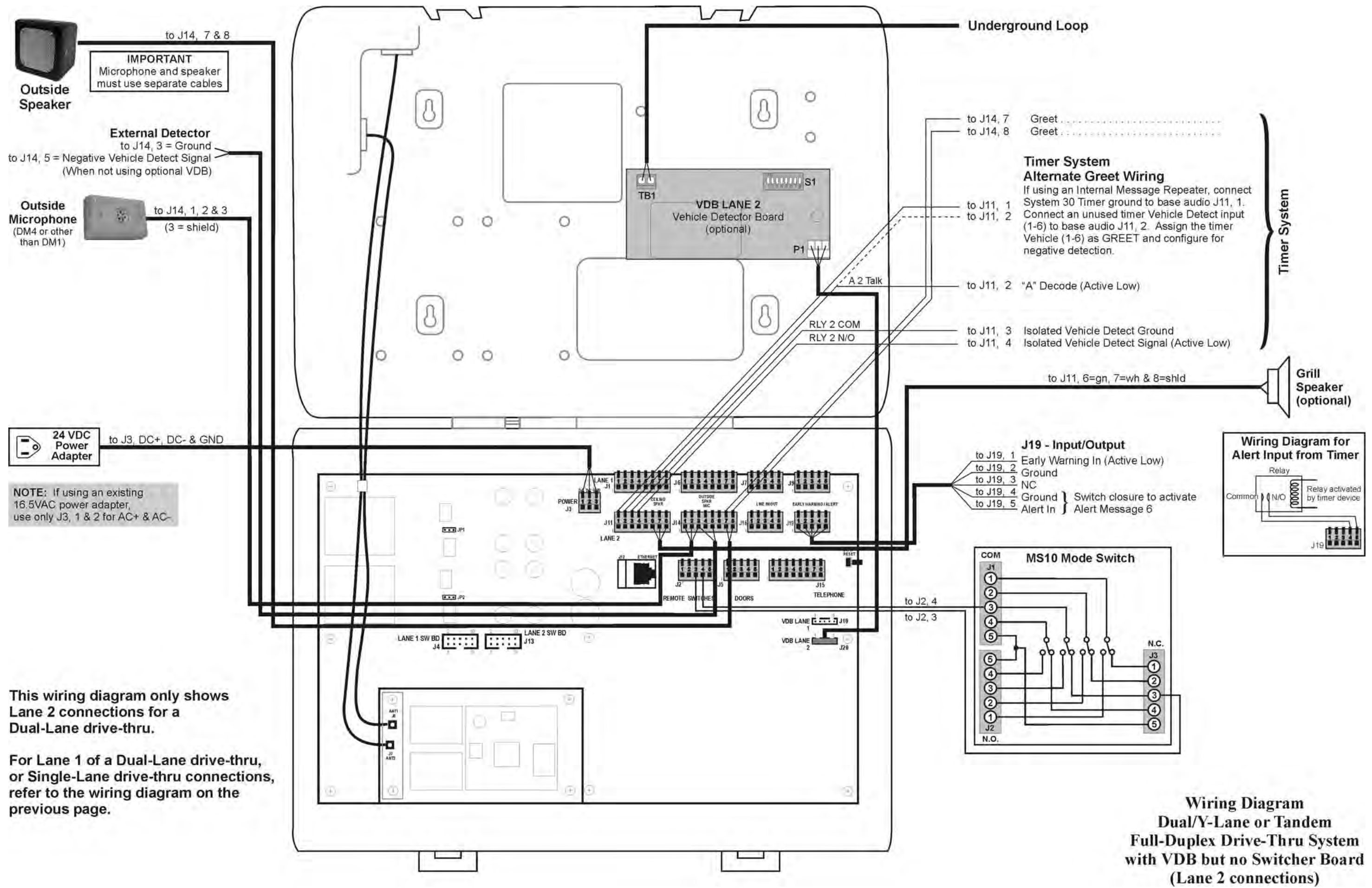

Figure 30.

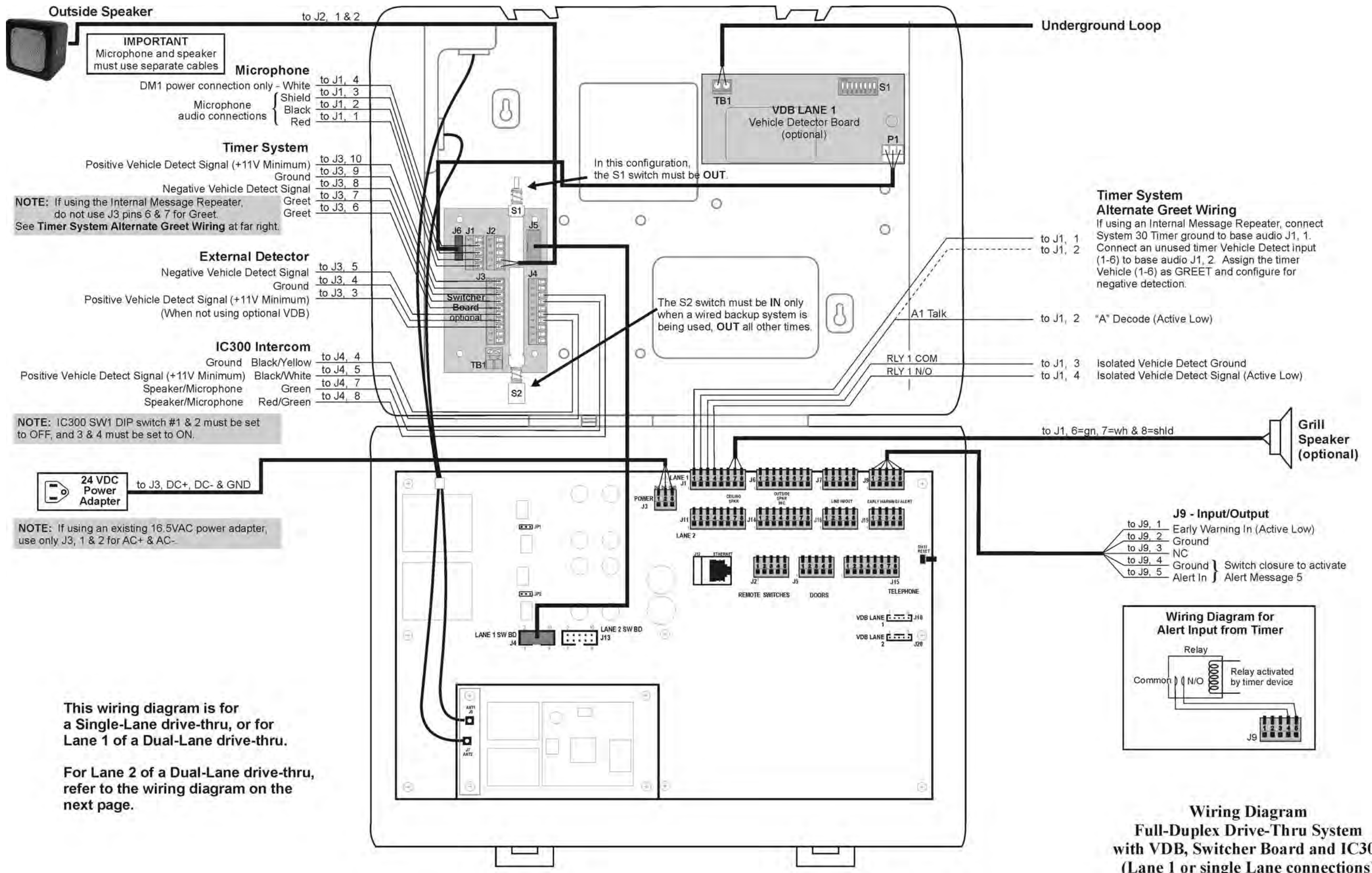

Figure 31.

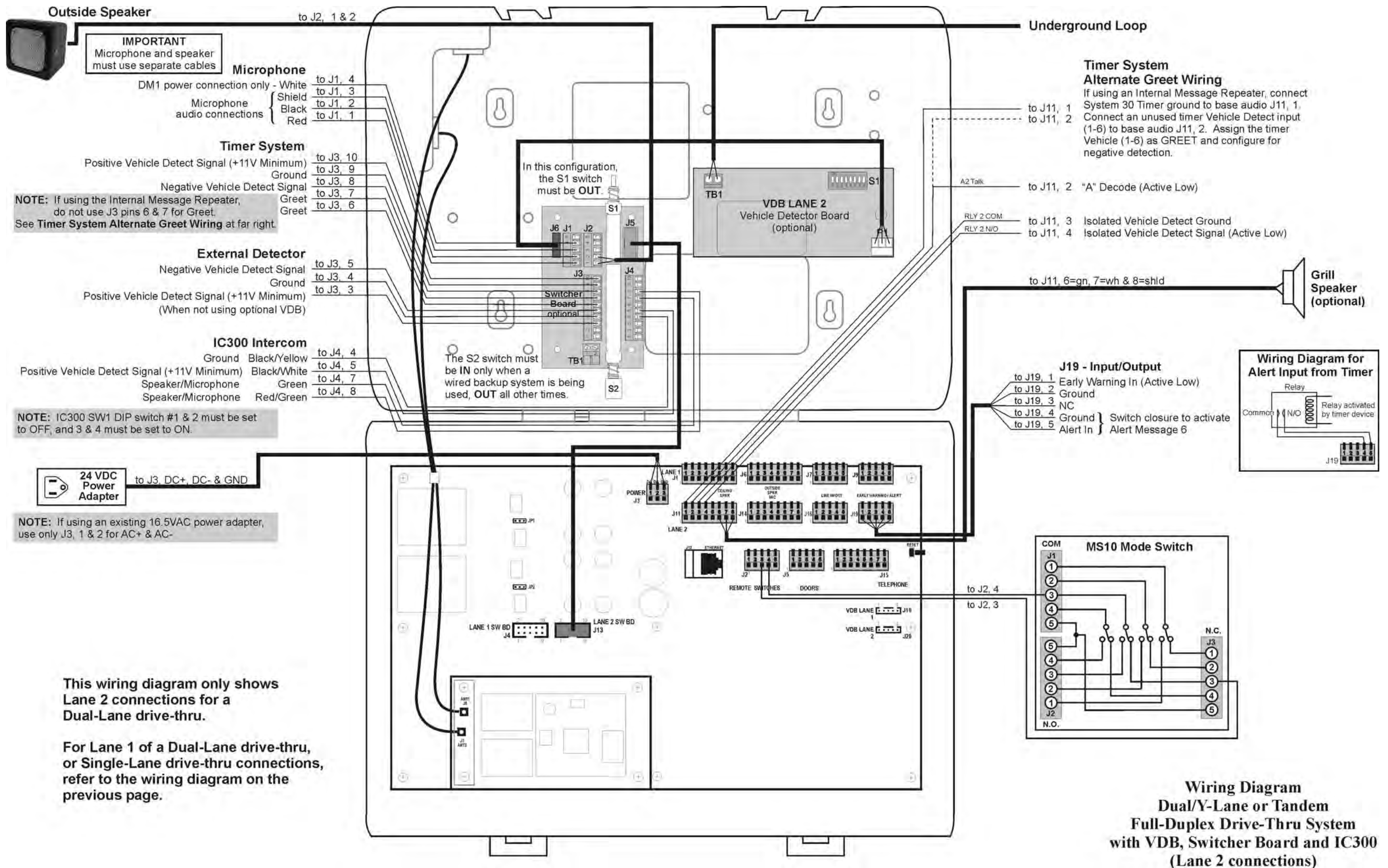

Figure 32.

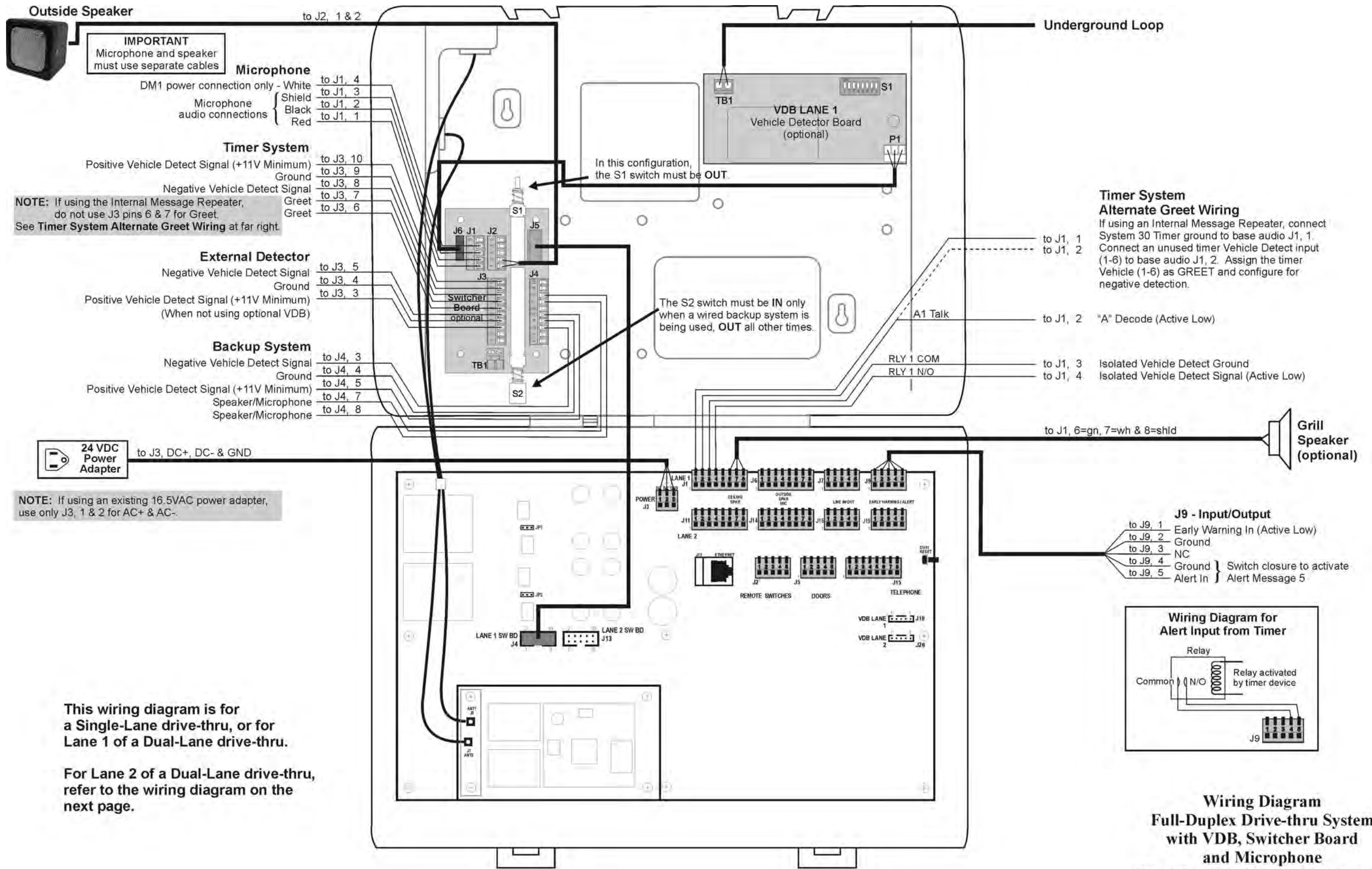

Figure 33.

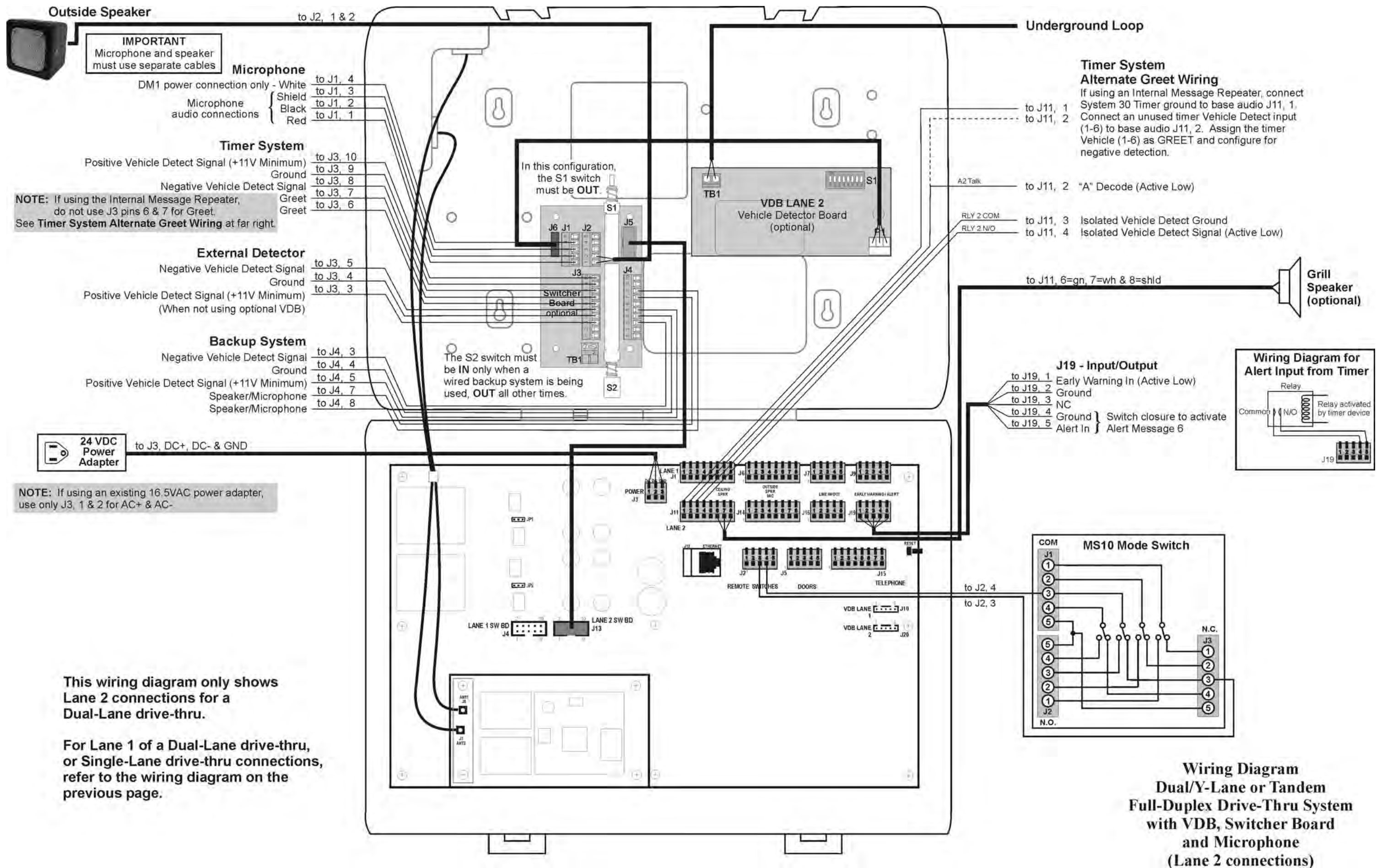

Figure 34.

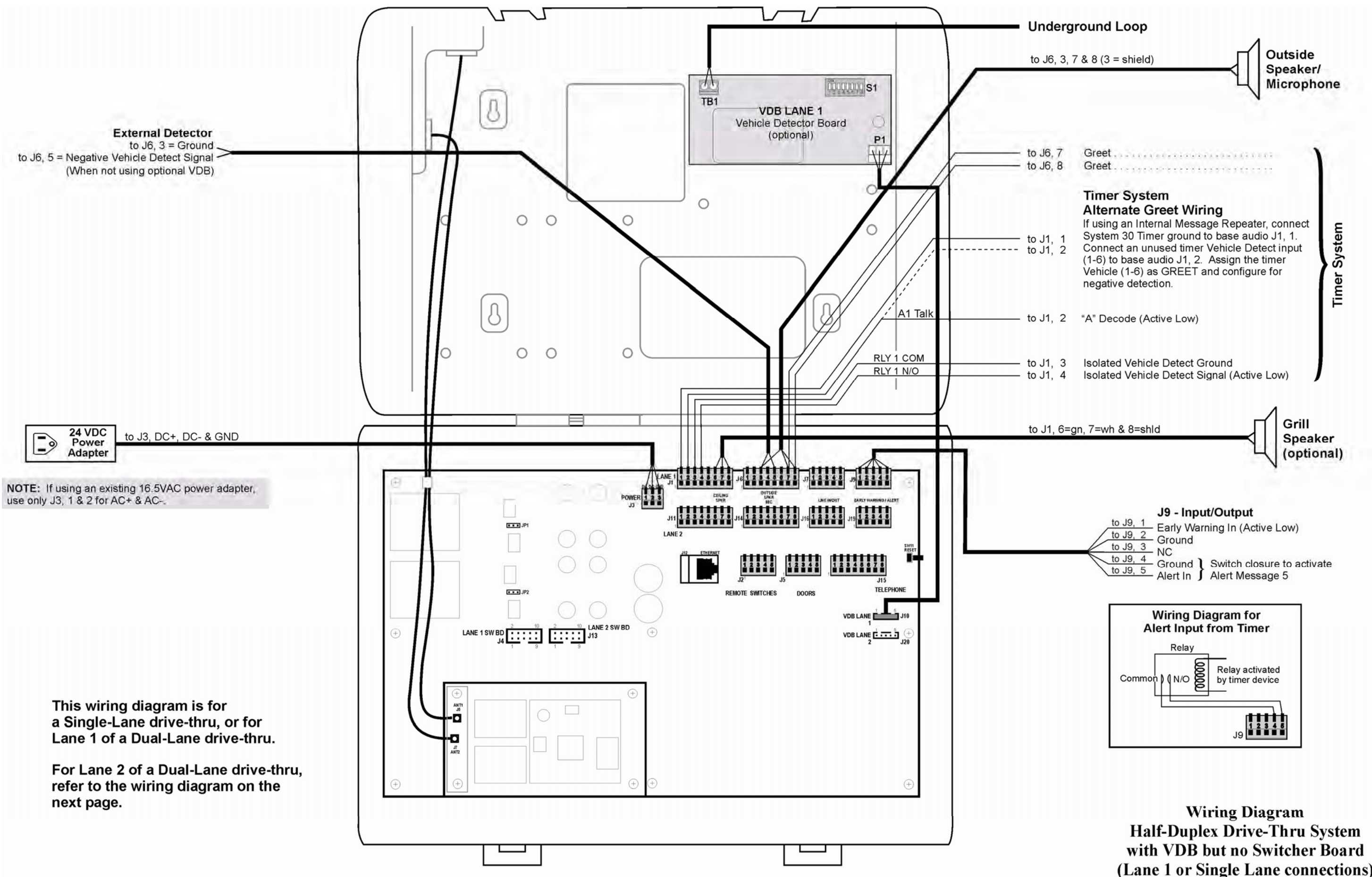

Figure 35.

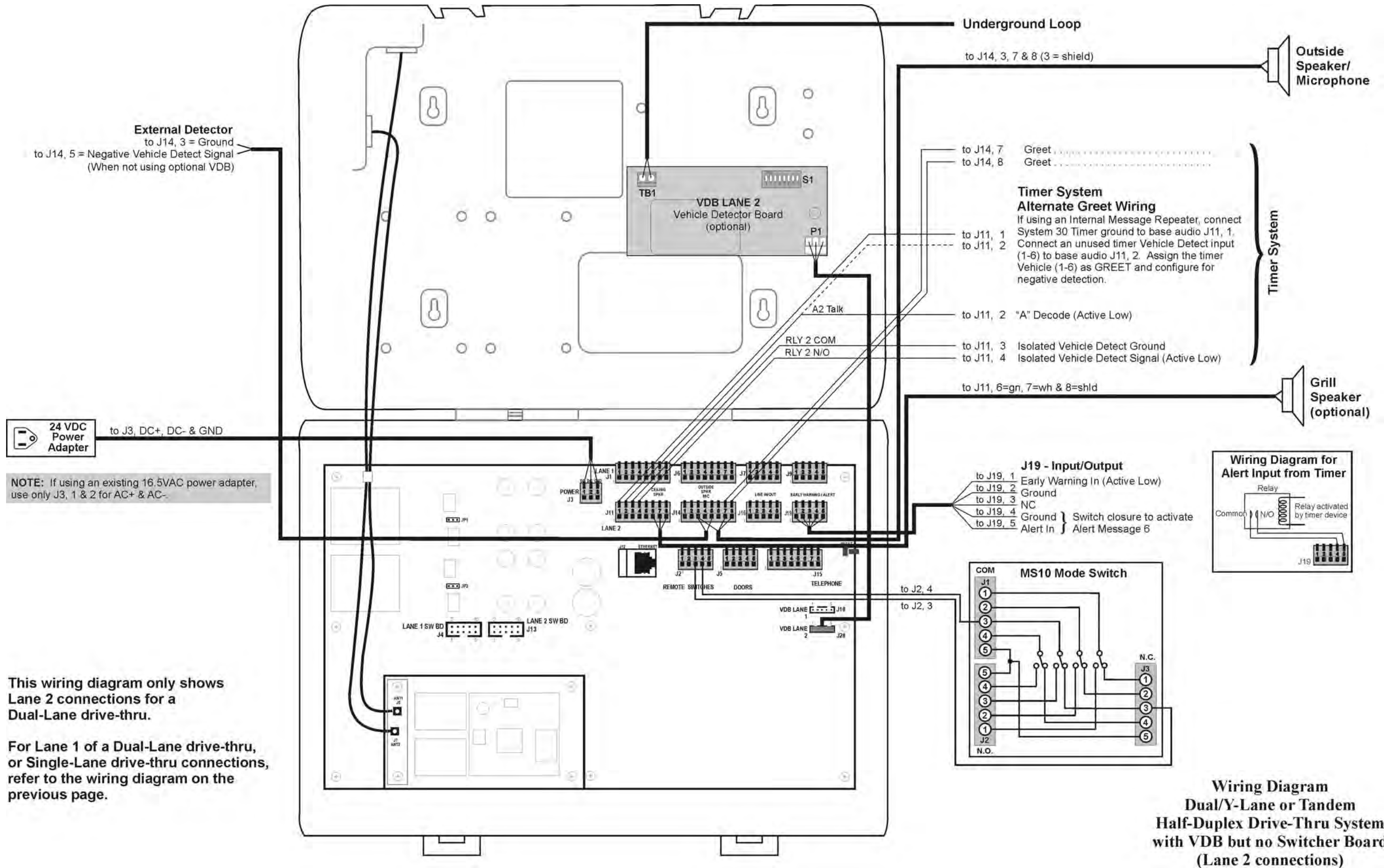

Figure 36.

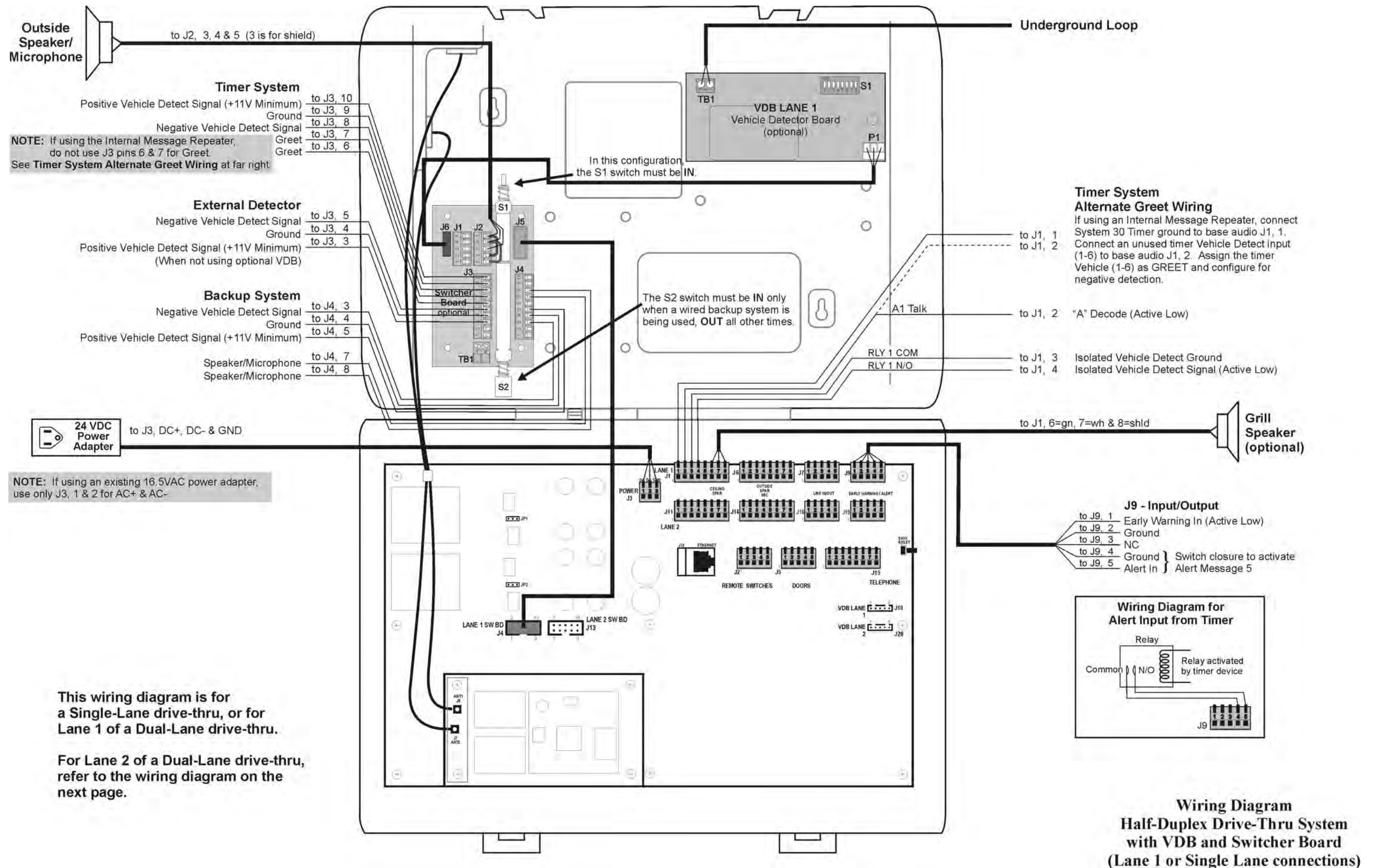

Figure 37.

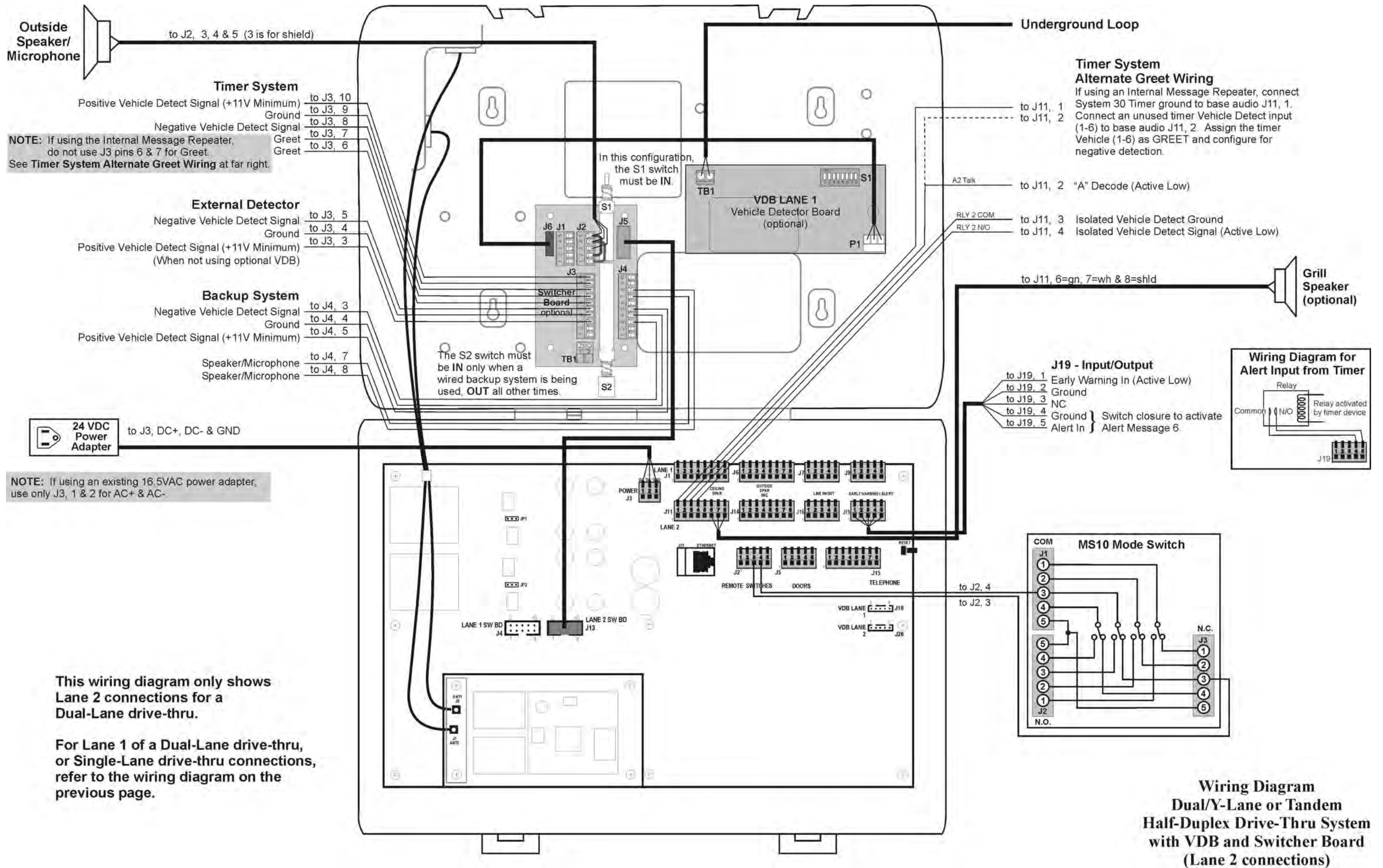

Figure 38.

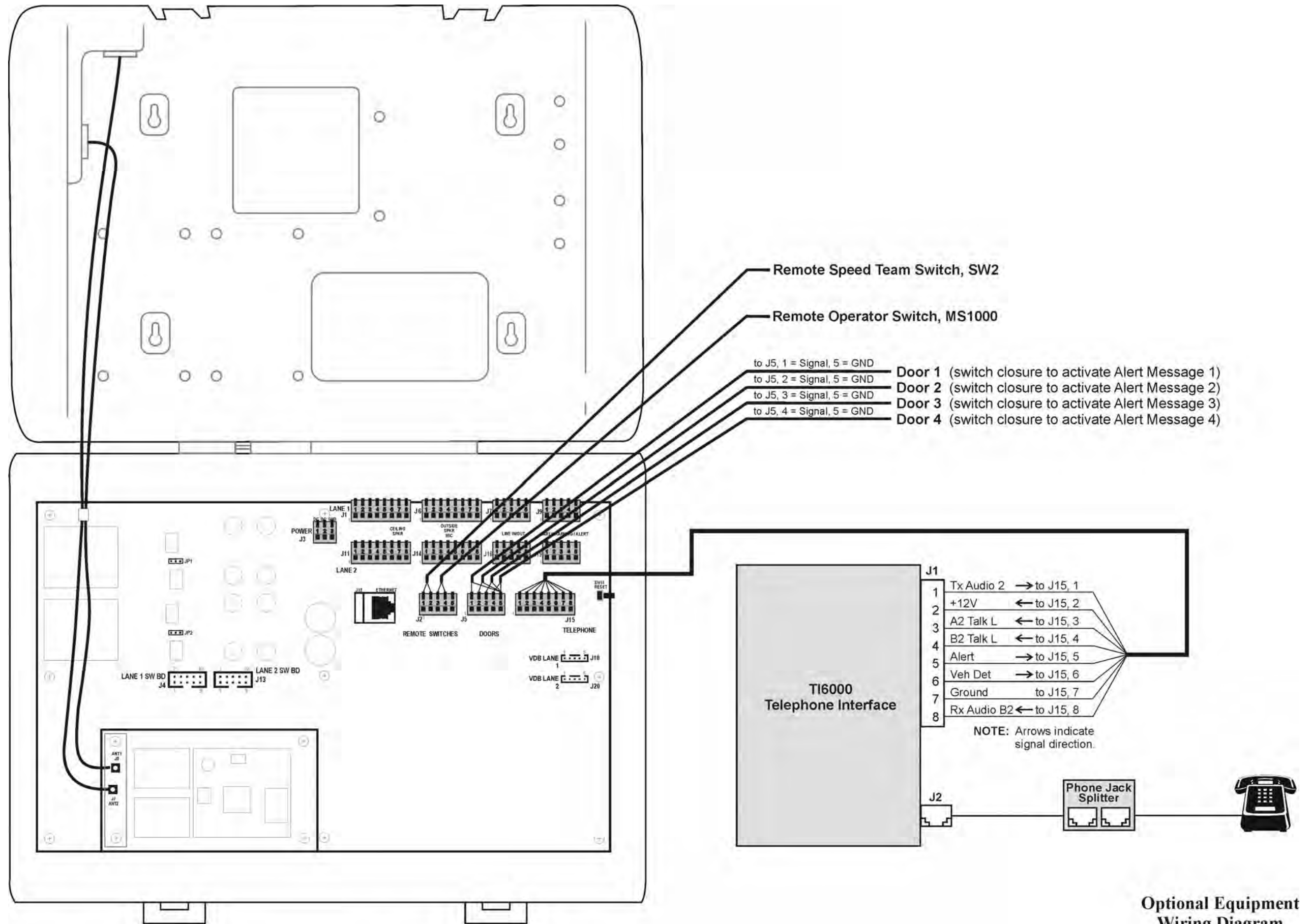

Figure 39.

Optional Equipment Wiring Diagram



WELCOME
TO THE
BAKERY!

pick up here











Memo

Re: Drive-Thru Sound Pressure Levels From the Menu Board or Speaker Post

The sound pressure levels from the menu board or speaker post are as follows:

1. Sound pressure level (SPL) contours (A weighted) were measured on a typical HME SPP2 speaker post. The test condition was for pink noise set to 84 dBA at 1 foot in front of the speaker. All measurements were conducted outside with the speaker post placed 8 feet from a non-absorbing building wall and at an oblique angle to the wall. These measurements should not be construed to guarantee performance with any particular speaker post in any particular environment. They are typical results obtained under the conditions described above.
2. The SPL levels are presented for different distances from the speaker post:

Distance from the Speaker (Feet)	SPL (dBA)
1 foot	84 dBA
2 feet	78 dBA
4 feet	72 dBA
8 feet	66 dBA
16 feet	60 dBA
32 feet	54 dBA

3. The above levels are based on factory recommended operating levels, which are preset for HME components and represent the optimum level for drive-thru operations in the majority of the installations.

Also, HME incorporates automatic volume control (AVC) into many of our Systems. AVC will adjust the outbound volume based on the outdoor, ambient noise level. When ambient noise levels naturally decrease at night, AVC will reduce the outbound volume on the system. See below for example:

Distance from Outside Speaker	Decibel Level of standard system with 45 dB of outside noise <u>without</u> AVC	Decibel level of standard system with 45 dB of outside noise <u>with</u> AVC active
1 foot	84 dBA	60 dBA
2 feet	78 dBA	54 dBA
4 feet	72 dBA	48 dBA
8 feet	66 dBA	42 dBA
16 feet	60 dBA	36 dBA

If there are any further questions regarding this issue please contact HME customer service at 1-800-848-4468.

Thank you for your interest in HME's products.