



Department of Public Works

Engineering Division

Robert F. Phillips, P.E., City Engineer

City-County Building, Room 115
210 Martin Luther King, Jr. Boulevard
Madison, Wisconsin 53703
Phone: (608) 266-4751
Fax: (608) 264-9275
engineering@cityofmadison.com
www.cityofmadison.com/engineering

Deputy City Engineer
Gregory T. Fries, P.E.
Deputy Division Manager
Kathleen M. Cryan
Principal Engineer 2
Christopher J. Petykowski, P.E.
John S. Fahrney, P.E.
Principal Engineer 1
Christina M. Bachmann, P.E.
Mark D. Moder, P.E.
Janet Schmidt, P.E.
Facilities & Sustainability
Jeanne E. Hoffman, Manager
Bryan Cooper, Principal Architect
Mapping Section Manager
Eric T. Pederson, P.S.
Financial Manager
Steven B. Danner-Rivers

RESIDENTIAL DRIVEWAY OPENING REQUEST

The street which abuts your property is scheduled for reconstruction. Drive aprons will be removed and replaced. Abutting the sidewalk, the new drive apron will be constructed to the width of the driveway behind the property line. All new drive aprons will usually be flared 2 feet on each side of the curb opening. If you desire a change in the driveway location or dimensions, it is necessary that you complete the diagram below, sign, and return this form within two (2) weeks to the City Engineering Division, Room 115, City-County Building, Madison, Wisconsin, 53703.

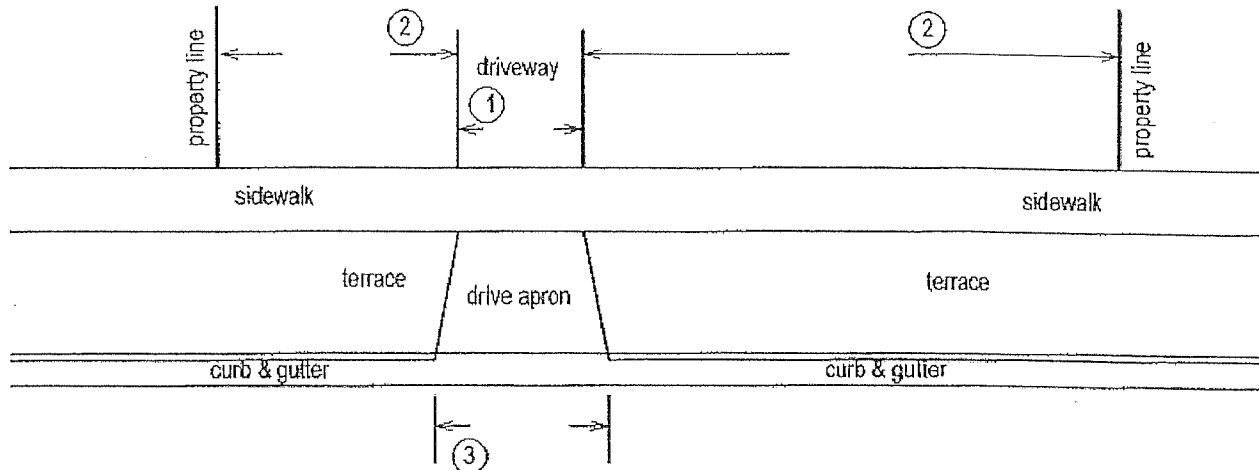

This diagram is not to any scale. Please provide:

1. The width of the driveway;
2. The distances from the edge of the driveway to the property lines;
3. The width of the desired curb opening

Residential curb openings are usually equal to the width of the driveway behind the property line at the sidewalk and an additional four (4) feet at the curb. The additional width at the curb opening is provided to facilitate turns into the driveway from the street and to taper the curb to full height. Depending on the width of the existing driveway, the City Ordinances allow up to a 20-foot wide apron at the sidewalk if necessary and requested by the property owner. In the case of vacant lots, no driveway opening will be made unless this form is returned to the City Engineering Division with the necessary information.

If the requested drive apron is larger than what has been estimated on the attached schedule of assessments, I hereby request that the City of Madison include this additional cost in my assessment for the Street Improvement.

Street Address _____

Phone No. _____

Signed _____

Date _____

Property Owner

This form is for a residential site only (a residential structure with 4 or less parking stalls). For additional information or questions, please contact the Project Engineer of the City Engineering Division at 266-4751.

C.D.



City of Madison

City of Madison
Madison, WI 53703
www.cityofmadison.com

Master

File Number: 54325

File ID: 54325	File Type: Resolution	Status: Passed
Version: 1	Reference:	Controlling Body: BOARD OF PUBLIC WORKS
Lead Referral: BOARD OF PUBLIC WORKS	Cost:	File Created Date : 01/07/2019
File Name: Approving Plans, Specifications, And Schedule Of Assessments For Groveland Terrace Assessment District - 2019.		Final Action: 02/05/2019
Title: Approving Plans, Specifications, And Schedule Of Assessments For Groveland Terrace Assessment District - 2019. (16th AD)		

Notes: Chris D.

Code Sections: CC Agenda Date: 02/05/2019

Indexes: Agenda Number: 12.

Sponsors: BOARD OF PUBLIC WORKS Effective Date: 02/08/2019

Attachments: BPW Hearing Notice Groveland Terrace Assessment District 2019.pdf, Groveland Terrace BPW Exhibit.pdf, Groveland Terrace Schedule of Assessments.pdf Enactment Number: RES-19-00117

Author: Rob Phillips Hearing Date:

Entered by: mhacker@cityofmadison.com Published Date:

Approval History

Version	Date	Approver	Action
1		Travis J. Martin	Approve

History of Legislative File

Version:	Acting Body:	Date:	Action:	Sent To:	Due Date:	Return Date:	Result:
1	Engineering Division	01/09/2019	Refer	BOARD OF PUBLIC WORKS	01/23/2019	01/23/2019	
Action Text: This Resolution was Refer to the BOARD OF PUBLIC WORKS due back on 1/23/2019							
Notes:							

1	BOARD OF PUBLIC WORKS	01/23/2019	RECOMMEND TO COUNCIL TO ADOPT UNDER SUSPENSION OF RULES 2.04, 2.05, 2.24, & 2.25 - REPORT OF OFFICER	Pass
---	-----------------------	------------	--	------

Action Text: Chris Dawson Engineering Division, presented details. Chair Lawton opened the public hearing. T. Lasure registered as neither for nor against, and asked questions about the when the payment would be due. P. Grubb registered to speak and voiced concern over the billing of the the assessment and how the costs were more for him and he did not think this was fair. The Board discussed this with a 15 year payback. A motion was made by Clausius, seconded by Ald. Tierney, to RECOMMEND TO COUNCIL TO ADOPT UNDER SUSPENSION OF RULES 2.04, 2.05, 2.24 & 2.25 - PUBLIC HEARING. The motion passed by voice vote/other. This was passed with a 15 year payback.

1	COMMON COUNCIL	02/05/2019	Adopt Under Suspension of Rules 2.04, 2.05, 2.24, and 2.25, and Close the Public Hearing	Pass
---	----------------	------------	--	------

Action Text: A motion was made by Baldeh, seconded by Carter, to Adopt Under Suspension of Rules 2.04, 2.05, 2.24, and 2.25, and Close the Public Hearing. The motion passed by voice vote/other.

Notes:

Text of Legislative File 54325

Fiscal Note

The proposed resolution approves plan documents for the reconstruction of Groveland Terrace at an estimated cost of \$1,330,000. The project is funded within the adopted 2019 capital budget for Engineering Major Streets via the Reconstruction Streets program. Funding is provided by GO Borrowing, special assessments, and associated utility components as follows:

Major Streets - \$831,000
Stormwater Utility - \$24,000
Sewer Utility - \$375,000

MUNIS:

11872

Title

Approving Plans, Specifications, And Schedule Of Assessments For Groveland Terrace Assessment District - 2019. (16th AD)

Body

The Board of Public Works and the City Engineer having made reports of all proceedings in relation to the improvement of Groveland Terrace Assessment District - 2019 pursuant to a resolution of the Common Council, RES-19-00019, ID No. 53962, adopted 01/08/19, which resolution was adopted thereto, and the provisions of the Madison General Ordinances and the Wisconsin Statutes in such case made and provided, and the Common Council being fully advised.

BE IT RESOLVED:

1. That the City at large is justly chargeable with and shall pay the sum of \$ 1,076,255.37 of the entire cost of said improvement.

2. That for those eligible property owners requesting construction of a rain garden in the public right-of-way adjacent to their property shall execute the necessary waiver of special assessments on forms provided by the City Engineer;
3. That the sum assigned to each separate parcel, as indicated on the attached schedule of assessment, is hereby specially assessed upon each such parcel.
4. That the Common Council determines such special assessments to be reasonable.
5. That the work or improvement be carried out in accordance with the reports as finally approved.
6. That such work or improvement represents an exercise of the police power of the City of Madison.
7. That the plans & specifications and schedule of assessments in the Report of the Board of Public Works and the Report of the City Engineer for the above named improvement be and are hereby approved.
8. That the Board of Public Works be and is hereby authorized to advertise for and receive bids for the said improvements.
9. That the due date by which all such special assessments shall be paid in full is October 31st of the year in which it is billed, or,
10. That such special assessments shall be collected in Fifteen (15) equal installments, with interest thereon at 4.0 percent per annum, except those special assessments paid in full on or before October 31st of that year.
11. That the Mayor and City Clerk are hereby authorized to accept dedication of lands and/or easements from the Developer/Owner for public improvements located outside of existing public fee title or easement right-of-ways.

INSTALLMENT ASSESSMENT NOTICE

Notice is hereby given that a contract has been (or is about to be) let for Groveland Terrace Assessment District - 2019 and that the amount of the special assessment therefore has been determined as to each parcel of real estate affected thereby and a statement of the same is on file with the City Clerk; it is proposed to collect the same in fifteen (15) installments, as provided for by Section 66.0715 of the Wisconsin Statutes, with interest thereon at 4.0 percent per annum; that all assessments will be collected in installments as above provided except such assessments on property where the owner of the same has paid the assessment to the City Treasurer on or before the next succeeding November 1st.

NOTICE OF APPEAL RIGHTS

"Pursuant to Sec.4.09(14), Madison General Ordinances, as authorized by Sec. 66.0701(2), Wisconsin Statutes, any person against whose land a special assessment has been levied by this resolution has the right to appeal therefrom in the manner prescribed in Sec. 66.0703(12), Wisconsin Statutes, within forty (40) days of the day of the final determination of the Common Council, said date being the date of adoption of this resolution."

City of Madison Engineering Division - Schedule of Assessments

01/11/2019

Project Name: Groveland Terrace Assessment District - 2019

Project Limits: Pflaum Road to Tompkins Drive

Frontages listed are for Groveland Ter

*A factor has been applied for sidewalk and curb and gutter work adjacent to lots that about more than one street and are single-family or two-family residential dwellings.

Parcel No/ Zoning	Owner's Name/ Mailing Address	Parcel Location	Frontage LF	Street Reconstruction Items				Assessable Sidewalk				Curb & Gutter & Street				Sanitary Sewer Items				Total Assessment
				Remove Existing Drive Apron/Walk @		Replace Drive Apron @		Replace Terrace Walk @		Construct New Sidewalk @		(100% Assessable) New Curb, Gutter & Street @		Sanitary Sewer Reconnect @		Remove & Replace Sanitary Sewer Lateral @				
				SF	Cost	SF	Cost	SF	Cost	Factor	per LF	Factor	per LF	per Each	Cost	LF	Cost			
0710-212-0313-9 SR-C1	MURRAY, VICTORIA L 508 DOUGLAS TRL MADISON WI	508 Douglas Trl	91.95 L.F.	0	\$0.00	0	\$0.00	0	\$0.00	0.5	\$1,839.00	0.5	\$1,839.00	1	\$1,250.00	35	\$735.00	\$6,326.63		
0710-212-0202-4 SR-C1	LOY, JOAN L 5304 GROVELAND TER MADISON WI	5304 Groveland Ter	70.00 L.F.	0	\$0.00	142.5	\$865.00	0	\$0.00	1	\$2,800.00	1	\$2,800.00	1	\$1,250.00	35	\$735.00	\$9,490.00		
0710-212-0316-3 SR-C1	FOELKER, MEGHAN M MARILYN K FOELKER 5305 GROVELAND TER MADISON WI	5305 Groveland Ter	85.00 L.F.	220	\$440.00	170	\$1,020.00	0	\$0.00	1	\$3,400.00	1	\$3,400.00	1	\$1,250.00	35	\$735.00	\$11,520.00		
0710-212-0203-2 SR-C1	KOHOUT, ANTHONY J 5308 GROVELAND TER MADISON WI	5308 Groveland Ter	70.00 L.F.	0	\$0.00	142.5	\$865.00	0	\$0.00	1	\$2,800.00	1	\$2,800.00	1	\$1,250.00	35	\$735.00	\$9,490.00		
0710-212-0315-5 SR-C1	CHRISTOFFERSON, BRUCE W 5309 GROVELAND TER MADISON WI	5309 Groveland Ter	85.00 L.F.	0	\$0.00	210	\$1,260.00	0	\$0.00	1	\$3,400.00	1	\$3,400.00	1	\$1,250.00	35	\$735.00	\$11,320.00		
0710-212-0204-0 SR-C1	JADRO, TROY J 5312 GROVELAND TER MADISON WI	5312 Groveland Ter	70.00 L.F.	175	\$350.00	145	\$870.00	0	\$0.00	1	\$2,800.00	1	\$2,800.00	1	\$1,250.00	35	\$735.00	\$9,655.00		
0710-212-0205-8 SR-C1	KNIER, RYAN 4768 EAGLE CREST DR MADISON WI	5316 Groveland Ter	73.00 L.F.	215	\$430.00	205	\$1,230.00	0	\$0.00	1	\$2,920.00	1	\$2,920.00	1	\$1,250.00	35	\$735.00	\$10,560.00		
0710-212-0206-6 SR-C1	MORGAN, LONNIE 5320 GROVELAND TER MADISON WI	5320 Groveland Ter	67.00 L.F.	50	\$100.00	0	\$0.00	36	\$144.00	0.5	\$1,340.00	0.5	\$1,340.00	1	\$1,250.00	35	\$735.00	\$5,411.50		
0710-212-0901-2 SR-C1	HARTWIG, BRADLEY A JODY K HARTWIG 5400 GROVELAND TER MADISON WI	5400 Groveland Ter	76.50 L.F.	0	\$0.00	0	\$0.00	0	\$0.00	0.5	\$1,530.00	0.5	\$1,530.00	1	\$1,250.00	35	\$735.00	\$5,618.75		
0710-212-0812-1 SR-C1	LAJOCK, ROBERT H 5401 GROVELAND TER MADISON WI	5401 Groveland Ter	76.50 L.F.	35	\$70.00	0	\$0.00	36	\$144.00	0.5	\$1,530.00	0.5	\$1,530.00	1	\$1,250.00	35	\$735.00	\$5,832.75		
0710-212-0902-0 SR-C1	FLEMING, MARY ELLEN 5404 GROVELAND TER MADISON WI	5404 Groveland Ter	76.50 L.F.	165	\$310.00	135	\$810.00	0	\$0.00	1	\$3,060.00	1	\$3,060.00	1	\$1,250.00	35	\$735.00	\$10,372.50		
0710-212-0811-3 SR-C1	ALLING, VICKI L 5405 GROVELAND TER MADISON WI	5405 Groveland Ter	76.50 L.F.	0	\$0.00	150	\$900.00	0	\$0.00	1	\$3,060.00	1	\$3,060.00	1	\$1,250.00	35	\$735.00	\$10,152.50		
0710-212-0903-8 SR-C1	KRETSCHAM, DANIEL JAMES 5408 GROVELAND TER MADISON WI	5408 Groveland Ter	76.50 L.F.	0	\$0.00	165	\$990.00	0	\$0.00	1	\$3,060.00	1	\$3,060.00	1	\$1,250.00	35	\$735.00	\$10,242.50		
0710-212-0810-5 SR-C1	COPEL, RENEE 5409 GROVELAND TER MADISON WI	5409 Groveland Ter	76.50 L.F.	0	\$0.00	225	\$1,350.00	0	\$0.00	1	\$3,060.00	1	\$3,060.00	1	\$1,250.00	35	\$735.00	\$10,602.50		
0710-212-0904-6 SR-C1	OLUND, STEVE J 5412 GROVELAND TER MADISON WI	5412 Groveland Ter	76.50 L.F.	0	\$0.00	230	\$1,380.00	0	\$0.00	1	\$3,060.00	1	\$3,060.00	1	\$1,250.00	35	\$735.00	\$10,632.50		

City of Madison Engineering Division - Schedule of Assessments

Project Name: Groveland Terrace Assessment District - 2019
 Project Limits: Pflaum Road to Tompkins Drive
 Frontages listed are for Groveland Ter
 *A factor has been applied for sidewalk and curb and gutter work adjacent to lots that abut more than one street and are single-family or two-family residential dwellings.

Parcel No./ Zoning	Owner's Name / Mailing Address	Parcel Location	Frontage L.F.	Street Reconstruction Items				Assessable Sidewalk (100% Assessable)				Curb & Gutter & Street (100% Assessable)				Sanitary Sewer Items				Total Assessment		
				Remove Existing Drive Apron/Walk @ SF	Replace Drive Apron @ SF	Replace Terrace Walk @ SF	Factor	Construct New Sidewalk @ LF	Factor	New Curb, Gutter & Street @ LF	Factor	Sanitary Sewer Reconnect @ per LF	Sanitary Sewer Reconnect @ per LF	Remove & Replace Sanitary Sewer Lateral @ per LF	Cost							
0710-212-0809-8 SR-C1	OREN, PETER & THERESA 5413 GROVELAND TER MADISON WI	5413 Groveland Ter	76.50 L.F.	0	\$0.00	180	\$1,080.00	0	\$0.00	0	\$0.00	1	76.5	\$3,060.00	1	76.5	\$4,207.50	1	\$1,250.00	35	\$735.00	\$10,382.50
0710-212-0905-4 SR-C1	YEMBU, ANNA 5416 GROVELAND TER MADISON WI	5416 Groveland Ter	76.50 L.F.	200	\$400.00	170	\$1,020.00	0	\$0.00	0	\$0.00	1	76.5	\$3,060.00	1	76.5	\$4,207.50	1	\$1,250.00	35	\$735.00	\$10,672.50
0710-212-0808-0 SR-C1	LASURE, MEGAN R TYLER R LASURE 5417 GROVELAND TER MADISON WI	5417 Groveland Ter	76.50 L.F.	155	\$310.00	140	\$840.00	0	\$0.00	0	\$0.00	1	76.5	\$3,060.00	1	76.5	\$4,207.50	1	\$1,250.00	35	\$735.00	\$10,402.50
0710-212-0906-2 SR-C1	ZIEGLER, TYLER COURTNEY ZIEGLER 5420 GROVELAND TER MADISON WI	5420 Groveland Ter	76.50 L.F.	0	\$0.00	0	\$0.00	0	\$0.00	0	\$0.00	0.5	76.5	\$1,530.00	0.5	76.5	\$2,103.75	1	\$1,250.00	35	\$735.00	\$5,618.75
0710-212-0807-2 SR-C1	DUNSE, DAVID E & KELLY J 5421 GROVELAND TER MADISON WI	5421 Groveland Ter	76.50 L.F.	155	\$310.00	120	\$720.00	0	\$0.00	0	\$0.00	0.5	76.5	\$1,530.00	0.5	76.5	\$2,103.75	1	\$1,250.00	42	\$882.00	\$6,765.75
0710-212-1301-3 SR-C1	MARKGRAFF, JASON D JESSICA A DUNCAN 5500 GROVELAND TER MADISON WI	5500 Groveland Ter	85.00 L.F.	60	\$120.00	0	\$0.00	40	\$160.00	0	\$0.00	0.5	85	\$1,700.00	0.5	85	\$2,337.50	1	\$1,250.00	35	\$735.00	\$6,302.50
0710-212-1412-8 SR-C1	LINDSAY, LEONARD & MARIA 5501 GROVELAND TER MADISON WI	5501 Groveland Ter	90.00 L.F.	205	\$410.00	185	\$810.00	36	\$144.00	0	\$0.00	0.5	90	\$1,800.00	0.5	90	\$2,475.00	1	\$1,250.00	35	\$735.00	\$7,624.00
0710-212-1302-1 SR-C1	GRUBB, PATRICK J MADELINE TAYLOR 5504 GROVELAND TER MADISON WI	5504 Groveland Ter	85.00 L.F.	270	\$540.00	215	\$1,290.00	0	\$0.00	0	\$0.00	1	85	\$3,400.00	1	85	\$4,675.00	1	\$1,250.00	35	\$735.00	\$11,690.00
0710-212-1413-6 SR-C1	FITZGERALD, SUSAN A 5505 GROVELAND TER MADISON WI	5505 Groveland Ter	80.00 L.F.	205	\$410.00	165	\$990.00	0	\$0.00	0	\$0.00	1	80	\$3,200.00	1	80	\$4,400.00	1	\$1,250.00	35	\$735.00	\$10,965.00
0710-212-0317-1 SR-C1	SORENSON, ROGER & DONNA 509 PFLAUM RD MADISON WI	509 Pflaum Rd	85.00 L.F.	0	\$0.00	0	\$0.00	0	\$0.00	0	\$0.00	0.5	85	\$1,700.00	0.5	85	\$2,337.50	1	\$1,250.00	35	\$735.00	\$6,022.50
0710-212-0201-6 SR-C1	SHULTS, JEANNE M 601 PFLAUM RD MADISON WI	601 Pflaum Rd	79.90 L.F.	0	\$0.00	0	\$0.00	0	\$0.00	0	\$0.00	0.5	79.9	\$1,598.00	0.5	79.9	\$2,197.25	1	\$1,250.00	36	\$755.00	\$5,801.25
0710-212-4144 SR-C1	COOPER, SHAWN D 508 TOMPKINS DR MADISON WI	508 Tompkins Dr	90.10 L.F.	0	\$0.00	0	\$0.00	0	\$0.00	0	\$0.00	0.5	90.1	\$1,802.00	0.5	90.1	\$2,477.75	1	\$1,250.00	35	\$735.00	\$6,254.75
0710-212-1303-5 SR-C1	RICHARD, JOHN W 600 TOMPKINS DR MADISON WI	600 Tompkins Dr	90.20 L.F.	0	\$0.00	0	\$0.00	0	\$0.00	0	\$0.00	0.5	90.2	\$1,804.00	0.5	90.2	\$2,480.50	1	\$1,250.00	35	\$735.00	\$6,269.50
TOTALS				2100	\$4,200.00	3250	\$19,500.00	148	\$592.00	2300.2	\$72,303.00	2300.2	\$89,416.63	29	\$36,250.00	1023	\$21,463.00					\$253,744.63