

AFFIDAVIT OF MAILING

STATE OF WISCONSIN)
) ss.
COUNTY OF DANE)

Marsha A. Hacker, being first duly sworn on oath, deposes and says that:

Legistar No. 45969

1. She is an Program Assistant I with the Office of the City Engineer, City of Madison, Dane County, Wisconsin, and did on the 27th day of March, at approximately 12:15 pm placed in envelopes addressed to each interested owner of respective addresses as indicated by attached assessment list, a true and correct copy of the notice of assessments for the project titled Approving Plans, Specifications, and Schedule of Assessments for Yuma Drive Resurfacing Assessment District - 2017.

2. She did and delivered the envelopes to the Mail Room of the Dane County Printing and Services Division, 210 Martin Luther King, Jr. Blvd., in the City of Madison, Dane County Wisconsin, for postage and depositing in the United States Mail.

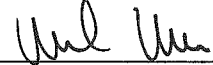

Marsha A. Hacker

Subscribed and sworn to before me
this 28th day of March, 2017

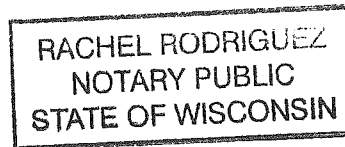

Rachel Rodriguez
Notary Public, State of Wisconsin

My Commission expires: 6/26/20





Finance Department

Room 406
210 Martin Luther King, Jr. Boulevard
Madison, Wisconsin 53703-3345
PH 608 266 4671
FAX 608 267 8705
finance@cityofmadison.com

Dear Property Owner:

The City of Madison has levied a special assessment on your property as shown on the enclosed Common Council resolution. This is an estimated assessment. When construction has been completed, the actual cost of the improvement will be determined. The amount of the assessment will then be adjusted accordingly, and a formal bill sent to you. The final bill will be equal to or less than the estimate unless you authorize additional work.

When you receive the bill, there are two options for payment: (1) the entire amount may be paid without interest by October 31 of the year you receive the bill (usually the next calendar year after the actual construction); or (2) if not paid in full by October 31, the assessment may be paid in installments with one equal part of the assessment plus interest included on your tax bill at the end of each year. Interest on each installment is calculated at three percent (3.0%) per year. In the first year of the assessment, interest is calculated only from the date of bill.

There may be situations, such as selling or refinancing your property, where you will be required at the closing to pay the estimated assessment before the work is completed. If the final amount is more than the estimate, any payments you have made will be credited and a bill sent out for the difference. If the final bill is less, any overpayment of principal and interest will be refunded. Refunds will be issued to the owner of record at the time of refund unless you provide the Finance Department with other refund instructions separate from the payment itself.

If your gross annual income is less than \$46,100 (for a single person, more for a family) and you live on the property where the work is done, you may qualify for a loan to pay the assessment. For information on the loan criteria, call (608) 266-4008.

We hope this letter will assist you in understanding the special assessment payment procedure. If you have any questions, please contact the City Finance Department, Room 406, 210 Martin Luther King, Jr. Blvd. or call (608) 266-4008.

Sincerely,

David Schmiedicke
Finance Director

Enclosure

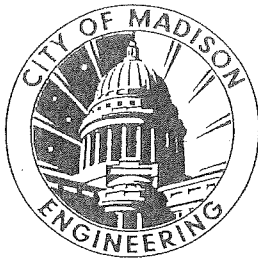

Department of Public Works
Engineering Division
 Robert F. Phillips, P.E., City Engineer
 City-County Building, Room 115
 210 Martin Luther King, Jr. Boulevard
 Madison, Wisconsin 53703
 Phone: (608) 266-4751
 Fax: (608) 264-9275
engineering@cityofmadison.com
www.cityofmadison.com/engineering

Assistant City Engineer
 Michael R. Dailey, P.E.
Principal Engineer 2
 Gregory T. Fries, P.E.
 Christopher J. Petykowski, P.E.
Principal Engineer 1
 Christina M. Bachmann, P.E.
 Eric L. Dundee, P.E.
 John S. Fahrney, P.E.
Facilities & Sustainability
 Jeanne E. Hoffman, Manager
Operations Manager
 Kathleen M. Cryan
Mapping Section Manager
 Eric T. Pederson, P.S.
Financial Manager
 Steven B. Danner-Rivers

RESIDENTIAL DRIVEWAY OPENING REQUEST

The street which abuts your property is scheduled for reconstruction. Drive aprons will be removed and replaced. Abutting the sidewalk, the new drive apron will be constructed to the width of the driveway behind the property line. All new drive aprons will usually be flared 2 feet on each side of the curb opening. If you desire a change in the driveway location or dimensions, it is necessary that you complete the diagram below, sign, and return this form within two (2) weeks to the City Engineering Division, Room 115, City-County Building, Madison, Wisconsin, 53703.

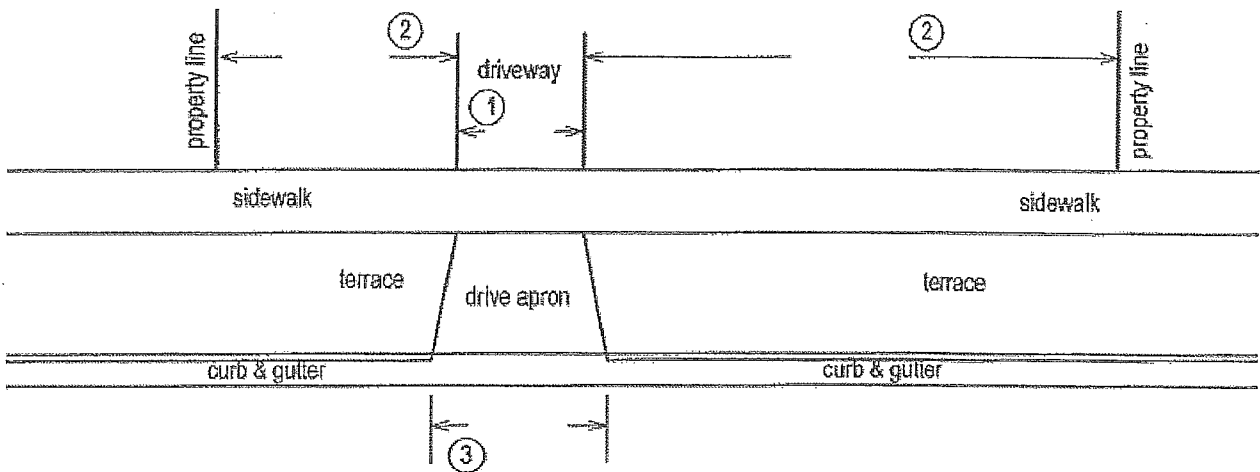

This diagram is not to any scale. Please provide:

1. The width of the driveway;
2. The distances from the edge of the driveway to the property lines;
3. The width of the desired curb opening

Residential curb openings are usually equal to the width of the driveway behind the property line at the sidewalk and an additional four (4) feet at the curb. The additional width at the curb opening is provided to facilitate turns into the driveway from the street and taper the curb to full height. The City Ordinances allow up to a 20-foot wide apron at the sidewalk if necessary and requested by the property owner. In the case of vacant lots, no driveway opening will be made unless this form is returned to the City Engineering Division with the necessary information.

If the requested drive apron is larger than what has been estimated on the attached schedule of assessments, I hereby request that the City of Madison include this additional cost in my assessment for the Street Improvement.

Street Address _____

Phone No. _____

Signed _____

Date _____

Property Owner

This form is for a residential site only (a residential structure with 4 or less parking stalls). For additional information or questions, please contact the Project Engineer of the City Engineering Division at 266-4751.

S.S.



City of Madison

City of Madison
Madison, WI 53703
www.cityofmadison.com

Master

File Number: 45969

File ID: 45969	File Type: Resolution	Status: Passed
Version: 1	Reference:	Controlling Body: BOARD OF PUBLIC WORKS
Lead Referral: BOARD OF PUBLIC WORKS	Cost:	File Created Date : 01/31/2017
File Name: Approving Plans, Specifications, And Schedule Of Assessments For Yuma Drive Resurfacing Assessment District - 2017.		Final Action: 03/21/2017

Title: Approving Plans, Specifications, And Schedule Of Assessments For Yuma Drive Resurfacing Assessment District - 2017.

Notes: Steve Sonntag

Code Sections:	CC Agenda Date: 03/21/2017
Indexes:	Agenda Number: 5.
Sponsors: BOARD OF PUBLIC WORKS	Effective Date: 03/23/2017
Attachments: BPW Hearing Notice Yuma.pdf, BPW Hearing YUMA NOTES BPW.pdf, Yuma Display.pdf, 11435 YumaAssessment.pdf, CC Hearing Notice Yuma Dr 45969.pdf	Enactment Number: RES-17-00209
Author: Rob Phillips, City Engineer	Hearing Date: 03/21/2017
Entered by: mhacker@cityofmadison.com	Published Date:

Approval History

Version	Date	Approver	Action
1	03/13/2017	Travis J. Martin	Approve

History of Legislative File

Ver- sion:	Acting Body:	Date:	Action:	Sent To:	Due Date:	Return Date:	Result:
1	Engineering Division	01/31/2017	Refer	BOARD OF PUBLIC WORKS	03/08/2017		
Action Text: This Resolution was Refer to the BOARD OF PUBLIC WORKS							
Notes:							

1	BOARD OF PUBLIC WORKS	03/08/2017	RECOMMEND TO COUNCIL TO ADOPT UNDER SUSPENSION OF RULES 2.04, 2.05, 2.24 & 2.25 - PUBLIC HEARING	Pass
---	-----------------------	------------	--	------

Action Text: Steve Sonntag, City Engineering Division, presented project details. There were no members of the public present for the public hearing. Motion made by Ald. Palm, second by Dahl to RECOMMEND TO COUNCIL TO ADOPT UNDER SUSPENSION OF RULES 2.04, 2.05, 2.24 & 2.25 - PUBLIC HEARING. Motion passed on following vote:

Notes:

Ayes: 5 Harold P. Dahl; David J. Branson; Jaclyn D. Lawton; Kenneth G. Johnson and Larry Palm
 Excused: 3 Claudia Haack ; Sara Z. Walling and Paul E. Skidmore

1	COMMON COUNCIL	03/21/2017	Adopt Under Suspension of Rules 2.04, 2.05, 2.24, and 2.25, and Close the Public Hearing	Pass
---	----------------	------------	--	------

Action Text: A motion was made by Vermeer, seconded by Rummel, to Adopt Under Suspension of Rules 2.04, 2.05, 2.24, and 2.25, and Close the Public Hearing. The motion passed by voice vote/other.

Notes:

Text of Legislative File 45969

Fiscal Note

In the adopted 2017 capital budget Engineering Major Streets has budgeted \$10.29 million for the resurfacing of existing streets via the Pavement Management capital program (MUNIS 10540). The proposed resolution approves plans for the Yuma Drive resurfacing minor project at a total estimated cost of \$1,815,000 (MUNIS11435). Funding is provided by GO Borrowing, special assessments, and associated utility funding. The project cost to the associated City agencies is split as follows:

Major Streets - \$605,000
 Stormwater Utility - \$275,000
 Sewer Utility - \$440,000
 Water Utility - \$495,000
 Assessable Costs - \$180,000

MUNIS:

11435-402-170	\$525,000
11435-402-174	\$ 80,000
11435-84-174	\$275,000
11435-83-173	\$440,000
11435-86-130	\$495,000

Title

Approving Plans, Specifications, And Schedule Of Assessments For Yuma Drive Resurfacing Assessment District - 2017.

Body

The Board of Public Works and the City Engineer having made reports of all proceedings in relation to the improvement of Yuma Drive Resurfacing Assessment District - 2017 pursuant to

a resolution of the Common Council, RES-17-00032, ID No. 45374, adopted 1/3/2017, which resolution was adopted thereto, and the provisions of the Madison General Ordinances and the Wisconsin Statutes in such case made and provided, and the Common Council being fully advised.

BE IT RESOLVED:

1. That the City at large is justly chargeable with and shall pay the sum of \$1,635,000.00 of the entire cost of said improvement.
2. That for those eligible property owners requesting construction of a rain garden in the public right-of-way adjacent to their property shall execute the necessary waiver of special assessments on forms provided by the City Engineer;
3. That the sum assigned to each separate parcel, as indicated on the attached schedule of assessment, is hereby specially assessed upon each such parcel.
4. That the Common Council determines such special assessments to be reasonable.
5. That the work or improvement be carried out in accordance with the reports as finally approved.
6. That such work or improvement represents an exercise of the police power of the City of Madison.
7. That the plans & specifications and schedule of assessments in the Report of the Board of Public Works and the Report of the City Engineer for the above named improvement be and are hereby approved.
8. That the Board of Public Works be and is hereby authorized to advertise for and receive bids for the said improvements.
9. That the due date by which all such special assessments shall be paid in full is October 31st of the year in which it is billed, or,
10. That such special assessments shall be collected in eight (8) equal installments, with interest thereon at 3.0 percent per annum, except those special assessments paid in full on or before October 31st of that year.
11. That the Mayor and City Clerk are hereby authorized to accept dedication of lands and/or easements from the Developer/Owner for public improvements located outside of existing public fee title or easement right-of-ways.

INSTALLMENT ASSESSMENT NOTICE

Notice is hereby given that a contract has been (or is about to be) let for Yuma Drive Resurfacing Assessment District - 2017 and that the amount of the special assessment therefore has been determined as to each parcel of real estate affected thereby and a statement of the same is on file with the City Clerk; it is proposed to collect the same in eight (8) installments, as provided for by Section 66.0715 of the Wisconsin Statutes, with interest thereon at 3.0 percent per annum; that all assessments will be collected in installments as above provided except such assessments on property where the owner of the same has paid the assessment to the City Treasurer on or before the next succeeding November 1st.

NOTICE OF APPEAL RIGHTS

"Pursuant to Sec.4.09(14), Madison General Ordinances, as authorized by Sec. 66.0701(2), Wisconsin Statutes, any person against whose land a special assessment has been levied by this resolution has the right to appeal therefrom in the manner prescribed in Sec. 66.0703(12), Wisconsin Statutes, within forty (40) days of the day of the final determination of the Common Council, said date being the date of adoption of this resolution."

City of Madison Engineering Division - Schedule of Assessments

Project Name: Yuma Drive Resurfacing Assessment District - 2017

Project Limits: Yuma Dr: South Midvale Blvd to Nakoma Rd

Frontages listed are for: Yuma Dr

Project ID: 11435

Parcel No./ Zoning	Owner's Name / Mailing Address	Situation Address	Frontage (LF)	Street Reconstruction Items			Sanitary Sewer Items			TOTAL ASSMNT						
				Remove and Replace Sidewalk \$6.00 per SF		Remove and Replace Drive Apron @ \$7.00 per SF	Remove and Replace Curb and Gutter @ \$30.00 per LF		Sanitary Sewer Reconnection		Remove and Replace Sanitary Lateral @ \$21.11 per LF					
				Factor	SF	Cost	Factor	LF	Cost		Each	LF	Cost			
0709-321-0308-2 TR-C1	YOUNG, ROBERT & DEBORAH 901 S MIDVALE BLVD YUMA DR MADISON WI	901 S Midvale Blvd Yuma Dr	140.00 L.F. 75.00 L.F.	0.5	106.00	\$318.00	60.00	\$420.00	0.5	95.00	\$1,425.00	1.00	\$450.00	30.00	\$633.30	\$3,246.30
0709-321-0712-5 TR-C1	HAMMER, ROSS EDWARD 3930 NAKOMA RD YUMA DR MADISON WI	3930 Nakoma Rd Yuma Dr	61.70 L.F. 116.2 L.F.	0.5	0.00	\$0.00	0.00	\$0.00	0.5	0.00	\$0.00	0.00	\$0.00	0.00	\$0.00	\$0.00
0709-321-0817-3 TR-C1	WESTMINSTER PRESBYTERIAN CHURCH 4100 NAKOMA RD. MADISON WI	4100 Nakoma Rd Yuma Dr	304.00 L.F. 143.5 L.F.	1.0	106.00	\$636.00	100.00	\$700.00	1.0	20.00	\$600.00	1.00	\$450.00	35.00	\$738.85	\$3,124.85
0709-294-2710-6 TR-C1	MAGNUSON, JOHN J. 870 WABAN HILL MADISON WI	870 Waban Hill	140.60 L.F.	0.5	106.00	\$318.00	0.00	\$0.00	0.5	95.00	\$1,425.00	1.00	\$450.00	35.00	\$738.85	\$2,931.85
0709-294-2807-1 TR-C1	HITCHCOCK, JOHN W EMILY WORSHAM ARTHUR 871 WABAN HILL MADISON WI	871 Waban Hill Yuma Dr	138.00 L.F. 60.0 L.F.	0.5	106.00	\$318.00	0.00	\$0.00	0.5	106.00	\$1,580.00	1.00	\$450.00	35.00	\$738.85	\$3,096.85
0709-321-0208-4 TR-C1	LEISMAN, GARY & WENDY L ADAMS 901 WABAN HILL MADISON WI	901 Waban Hill Yuma Dr	150.00 L.F. 65.0 L.F.	0.5	184.00	\$552.00	0.00	\$0.00	0.5	100.00	\$1,500.00	1.00	\$450.00	38.00	\$802.18	\$3,304.18
0709-321-0363-6 TR-C1	GIRARD, ERIC D & GRETCHEN T GIRARD 902 WABAN HILL MADISON WI	902 Waban Hill Yuma Dr	60.00 L.F. 155.0 L.F.	0.5	0.00	\$0.00	55.00	\$385.00	0.5	190.00	\$2,850.00	0.00	\$0.00	0.00	\$0.00	\$3,235.00
0709-321-0711-7 TR-C1	CASEY, DAVID M J M CASEY & C L CASEY 3910 YUMA DR MADISON WI	3910 Yuma Dr	63.80 L.F.	1.0	106.00	\$636.00	140.00	\$980.00	1.0	20.00	\$600.00	1.00	\$450.00	35.00	\$738.85	\$3,404.85
0709-321-0801-6 TR-C1	SWANSON, CATHERINE L 3915 YUMA DR MADISON WI	3915 Yuma Dr	146.00 L.F.	0.5	0.00	\$0.00	0.00	\$0.00	0.5	0.00	\$0.00	0.00	\$0.00	0.00	\$0.00	\$0.00
0709-321-0710-9 TR-C1	LEUTHNER LIV TR, B L 3918 YUMA DR MADISON WI	3918 Yuma Dr	150.50 L.F.	0.5	106.00	\$318.00	280.00	\$1,980.00	0.5	20.00	\$300.00	1.00	\$450.00	35.00	\$738.85	\$3,766.85
0709-321-0102-8 TR-C1	BISHOP, PAUL M & LINDA M 4002 YUMA DR MADISON WI	4002 Yuma Dr	148.70 L.F.	0.5	0.00	\$0.00	55.00	\$385.00	0.5	150.00	\$2,250.00	0.00	\$0.00	0.00	\$0.00	\$2,635.00
0709-321-0632-5 TR-C1	CHOLLES, DEONESA C 4005 YUMA DR MADISON WI	4005 Yuma Dr	141.20 L.F.	0.5	0.00	\$0.00	45.00	\$315.00	0.5	155.00	\$2,325.00	0.00	\$0.00	0.00	\$0.00	\$2,640.00

City of Madison Engineering Division - Schedule of Assessments

Project Name: Yuma Drive Resurfacing Assessment District - 2017

Project Limits: Yuma Dr: South Midvale Blvd to Nakoma Rd

Frontages listed are for: Yuma Dr

Project ID: 11435

Parcel No./ Zoning	Owner's Name / Mailing Address	Frontage (LF)	Street Reconstruction Items				Sanitary Sewer Items				TOTAL ASSMNT				
			Remove and Replace Sidewalk \$6.00 per SF		Remove and Replace Drive Apron @ \$7.00 per SF		Remove and Replace Curb and Gutter @ \$30.00 per LF		Sanitary Sewer Reconnection			Remove and Replace Sanitary Lateral @ \$21.11 per LF			
			Factor	SF	Cost	SF	Cost	Factor	LF	Cost		Each	Cost	LF	Cost
0709-321-0801-0 TR-C1	SALTER, RICHARD C 4013 YUMA DR MADISON, WI	142.00 L.F.	0.5	106.00	\$318.00	166.00	\$1,155.00	0.5	130.00	\$1,950.00	1.00	\$450.00	35.00	\$738.85	\$4,611.85
0709-321-0101-0 TR-C1	ADNEY, JAMES R AND MELISSA G KEPNER 4018 YUMA DR MADISON, WI	151.70 L.F.	0.5	212.00	\$636.00	250.00	\$1,750.00	0.5	170.00	\$2,550.00	1.00	\$450.00	37.00	\$781.07	\$6,167.07
0709-321-0201-9 TR-C1	MURPHY, COLLEEN A 4101 YUMA DR MADISON, WI	134.30 L.F.	0.5	0.00	\$0.00	65.00	\$455.00	0.5	170.00	\$2,550.00	0.00	\$0.00	0.00	\$0.00	\$3,065.00
0709-294-2814-6 TR-C1	CRASS, KRISTIN M 4102 YUMA DR MADISON, WI	104.80 L.F.	0.5	106.00	\$318.00	0.00	\$0.00	0.5	115.00	\$1,725.00	1.00	\$450.00	35.00	\$738.85	\$3,231.85
0709-321-0202-6 TR-C1	HENSLE, KELLY TIMOTHY HENSLE 4105 YUMA DR MADISON, WI	55.00 L.F.	1.0	106.00	\$636.00	210.00	\$1,470.00	1.0	55.00	\$1,650.00	1.00	\$450.00	35.00	\$738.85	\$4,944.85
0709-294-2813-8 TR-C1	GOLDSCHMIDT, DAVID W SARAH EDGERTON 4108 YUMA DR MADISON, WI	80.00 L.F.	1.0	186.00	\$1,116.00	45.00	\$315.00	1.0	80.00	\$2,400.00	1.00	\$450.00	35.00	\$738.85	\$5,019.85
0709-321-0203-4 TR-C1	AGUILAR, DAVID M CLAIRE E AGUILAR 4109 YUMA DR MADISON, WI	55.00 L.F.	1.0	106.00	\$636.00	45.00	\$315.00	1.0	55.00	\$1,650.00	1.00	\$450.00	33.00	\$596.63	\$3,747.63
0709-294-2812-0 TR-C1	MOORE, ADRIANNA L KASEY P KILLOREN 4112 YUMA DR MADISON, WI	80.00 L.F.	1.0	236.00	\$1,416.00	190.00	\$1,350.00	1.0	80.00	\$2,400.00	1.00	\$450.00	40.00	\$844.40	\$6,440.40
0709-321-0204-2 TR-C1	SARBACKER, DANIEL J LINDSAY E KRUGER 4117 YUMA DR MADISON, WI	50.80 L.F.	1.0	132.00	\$792.00	40.00	\$280.00	1.0	50.80	\$1,524.00	1.00	\$450.00	35.00	\$738.85	\$3,784.85
0709-294-2811-2 TR-C1	MORGENTHALER, DIANE 4118 YUMA DR MADISON, WI	50.00 L.F.	1.0	106.00	\$636.00	180.00	\$1,260.00	1.0	50.00	\$1,500.00	1.00	\$450.00	38.00	\$802.18	\$4,648.18
0709-321-0205-0 TR-C1	MCGINN, E JANE 4121 YUMA DRIVE MADISON, WI	50.00 L.F.	1.0	285.00	\$1,590.00	180.00	\$1,260.00	1.0	50.00	\$1,500.00	1.00	\$450.00	35.00	\$738.85	\$5,538.85
0709-294-2810-4 TR-C1	WEISER, MICHAEL EMILY WEISER 4122 YUMA DR MADISON, WI	50.00 L.F.	1.0	106.00	\$636.00	175.00	\$1,225.00	1.0	50.00	\$1,500.00	1.00	\$450.00	35.00	\$738.85	\$4,549.85

City of Madison Engineering Division - Screenshot of Assessments

Project Name: Yuma Drive Resurfacing Assessment District - 2017

Yuma Dr: South Midvale Blvd to Nakoma Rd

Project Limits:
Frontages listed are for: Yuma Dr
Project ID: 11435

Parcel No./ Zoning	Owner's Name / Mailing Address	Situs Address	Frontage (LF)	Street Reconstruction Items			Sanitary Sewer Items			TOTAL ASSMNT		
				Remove and Replace Sidewalk \$5.00 per SF	Remove and Replace Drive Apron @ \$7.00 per SF	Remove and Replace Curb and Gutter @ \$30.00 per LF	Sanitary Sewer Reconnection \$450.00 each	Remove and Replace Sanitary Lateral @ \$21.11 per LF	Remove and Replace Sanitary Lateral @ \$21.11 per LF			
			Factor	SF	Cost	Factor	LF	Cost	Each	LF	Cost	
0709-321-0206-8 TR-C1	COCCARO, JENNIFER A CARLG COCCARO 4125 YUMA DR MADISON WI	4125 Yuma Dr	50.00 L.F.	1.0	106.00	\$636.00	1.0	50.00	1.00	35.00	\$738.65	\$4,374.85
0709-294-2809-7 TR-C1	VAUDREUIL, JOHN W & STEPHANIE R VAUDREUIL 4126 YUMA DR MADISON WI	4126 Yuma Dr	50.00 L.F.	1.0	106.00	\$636.00	1.0	50.00	1.00	35.00	\$738.65	\$4,549.85
0709-321-0207-6 TR-C1	MILLIN, KRISTIN M & EDWARD J RATAJ 4129 YUMA DR MADISON WI	4129 Yuma Dr	50.00 L.F.	1.0	265.00	\$1,590.00	1.0	50.00	1.00	35.00	\$738.65	\$4,593.85
0709-294-2808-9 TR-C1	WESTERGAARD, RYAN P MARY C WESTERGAARD 4130 YUMA DR MADISON WI	4130 Yuma Dr	50.00 L.F.	1.0	106.00	\$636.00	1.0	50.00	1.00	35.00	\$738.65	\$4,584.85
0709-294-2709-9 TR-C1	NORDEEN, DALE A 4206 YUMA DR MADISON WI	4206 Yuma Dr	50.00 L.F.	1.0	106.00	\$636.00	1.0	50.00	1.00	38.00	\$802.18	\$3,633.18
0709-294-2708-1 TR-C1	PASIC, THOMAS & SHARON 4210 YUMA DR MADISON WI	4210 Yuma Dr	50.00 L.F.	1.0	106.00	\$636.00	1.0	50.00	1.00	35.00	\$738.65	\$5,109.85
0709-321-0301-6 TR-C1	DIETER, DANIEL C & SUSAN E CONNER-DIETER 4213 YUMA DRIVE MADISON WI	4213 Yuma Dr	100.00 L.F.	1.0	106.00	\$636.00	1.0	106.00	1.00	30.00	\$633.30	\$5,844.30
0709-294-2707-3 TR-C1	MACK REV TRUST, J & T 4214 YUMA DR MADISON WI	4214 Yuma Dr	70.00 L.F.	1.0	106.00	\$636.00	1.0	70.00	1.00	32.00	\$675.52	\$5,261.52
0709-321-0302-4 TR-C1	CLIFTON, PETER SARAH CLIFTON 4217 YUMA DR MADISON WI	4217 Yuma Dr	70.00 L.F.	1.0	106.00	\$636.00	1.0	70.00	1.00	30.00	\$633.30	\$4,939.30
0709-294-2706-5 TR-C1	GILL, CAROLYN & DONALD E GILL 4218 YUMA DR MADISON WI	4218 Yuma Dr	70.00 L.F.	1.0	106.00	\$636.00	1.0	70.00	1.00	30.00	\$633.30	\$4,274.30
0709-321-0303-2 TR-C1	RASCHE, PRISCILLA H 284 STANYON CT BLOOMINGDALE IL	4221 Yuma Dr	70.00 L.F.	1.0	106.00	\$636.00	1.0	70.00	1.00	30.00	\$633.30	\$4,274.30
0709-294-2705-7 TR-C1	HOFFNER, JONATHAN ALAN MICHELLE OXLEY HOFFNER 4222 YUMA DR MADISON WI	4222 Yuma Dr	140.00 L.F.	1.0	106.00	\$636.00	1.0	140.00	1.00	35.00	\$738.65	\$7,284.85

City of Madison Engineering Division - Schedule of Assessments

Project Name: Yuma Drive Resurfacing Assessment District - 2017

Project Limits: Yuma Dr: South Midvale Blvd to Nakoma Rd

Frontages listed are for: Yuma Dr
Project ID: 11435

Parcel No./ Zoning	Owner's Name / Mailing Address	Site Address	Frontage (LF)	Street Reconstruction Items			Sanitary Sewer Items			TOTAL ASSMNT						
				Remove and Replace Sidewalk \$6.00 per SF	Remove and Replace Drive Apron @ \$7.00 per SF	Remove and Replace Curb and Gutter @ \$30.00 per LF	Sanitary Sewer Reconnection \$450.00 each	Remove and Replace Sanitary Lateral @ \$21.11 per LF								
				Factor	SF	Cost	Factor	LF	Cost		Each	LF	Cost			
0709-321-0304-0 TR-C1	JONES REV LIV TR, TB & JL 4301 YUMA DR MADISON WI	4301 Yuma Dr	70.00 L.F.	1.0	106.00	\$636.00	30.00	\$210.00	1.0	70.00	\$2,100.00	1.0	\$450.00	30.00	\$633.30	\$4,029.30
0709-321-0305-8 TR-C1	WEISS, BRUCE & CATHY OHARA WEISS 4305 YUMA DR MADISON WI	4305 Yuma Dr	75.00 L.F.	1.0	106.00	\$636.00	30.00	\$210.00	1.0	75.00	\$2,250.00		\$450.00	30.00	\$633.30	\$4,179.30
0709-294-2704-9 TR-C1	ROBERTS, RAYMOND & KATHRYN PADORR 4306 YUMA DR MADISON WI	4306 Yuma Dr	70.00 L.F.	1.0	106.00	\$636.00	40.00	\$280.00	1.0	70.00	\$2,100.00		\$450.00	30.00	\$633.30	\$4,099.30
0709-321-0306-6 TR-C1	COTA, STEPHANIE L 4309 YUMA DR MADISON WI	4309 Yuma Dr	70.00 L.F.	1.0	106.00	\$636.00	110.00	\$770.00	1.0	70.00	\$2,100.00		\$450.00	30.00	\$633.30	\$4,589.30
0709-294-2703-1 TR-C1	BRADLEY, JACQUELIN 4310 YUMA DR MADISON WI	4310 Yuma Dr	70.00 L.F.	1.0	212.00	\$1,272.00	125.00	\$875.00	1.0	70.00	\$2,100.00		\$450.00	30.00	\$633.30	\$5,330.30
0709-321-0307-4 TR-C1	FORTNEY, MATTHEW DANIAL CECELY ANNE CASTILLO 4313 YUMA DR MADISON WI	4313 Yuma Dr	75.00 L.F.	1.0	106.00	\$636.00	120.00	\$840.00	1.0	75.00	\$2,250.00		\$450.00	30.00	\$633.30	\$4,809.30
0709-294-2702-3 TR-C1	BUSH, DARREN & STEPHANIE 4314 YUMA DR MADISON WI	4314 Yuma Dr	95.00 L.F.	1.0	106.00	\$636.00	40.00	\$280.00	1.0	95.00	\$2,850.00		\$450.00	30.00	\$633.30	\$4,849.30
0709-294-2701-5 TR-C1	MATTHEWS, DAVID R B & CAMILLA K B MATTHEWS 4318 YUMA DR MADISON WI	4318 Yuma Dr	100.00 L.F.	0.5	106.00	\$318.00	40.00	\$280.00	0.5	120.00	\$1,800.00		\$450.00	30.00	\$633.30	\$3,481.30
TOTALS:					4872.00	\$25,818.00	4460.00	\$31,220.00		3477.80	\$80,094.00		\$17,100.00	1276.00	\$26,936.38	\$181,188.36

NOTE: A factor has been applied for sidewalk and curb and gutter work adjacent to lots that are more than one street and are single-family or two-family residential dwellings.