



# VANDEWALLE & ASSOCIATES INC.

May 29, 2019

Heather Stouder  
Department of Planning & Development  
City of Madison  
215 Martin Luther King, Jr. Blvd.  
Madison, WI 53710-2985

RE: 6810 Milwaukee Street (see attached addresses)  
KCG Development: Meadowlands Multi-Family

Dear Heather,

The following document and plans detail the Planned Unit Development: General Development Plan/Specific Implementation plan submittal for the Meadowlands Multi-Family Project, on behalf of KCG Development. This submittal reflects the Comprehensive Plan, Sprecher Neighborhood Plan, and previously approved (expired) PUD: GDP plans for this property.

We look forward to working with the City on the review and implementation of this neighborhood.

Sincerely,

Brian Munson  
Principal

APPLICANT:

KCG Development, LLC  
9333 North Meridian Street  
Suite 230  
Indianapolis, Indiana 46260  
Phone: (317) 409-7776  
Matt Gilhooly  
[Matt.Gilhooly@kcgcompanies.com](mailto:Matt.Gilhooly@kcgcompanies.com)

DESIGN TEAM:

*Architecture:*

Hooker DeJong Architects & Engineers  
549 Ottawa Avenue NW Ste 102  
Grand Rapids, Michigan 49503  
Eric Maring [ericm@hdjinc.com](mailto:ericm@hdjinc.com)

*Engineering/Landscape Architecture:*

Snyder & Associates  
5010 Voges Road  
Madison, Wisconsin 53718  
Phone: (608)838-0444  
Mike Calkins [mcalkins@snyder-associates.com](mailto:mcalkins@snyder-associates.com)  
Andy Meessman [ameessmann@snyder-associates.com](mailto:ameessmann@snyder-associates.com)

*Planning:*

Vandewalle & Associates  
120 East Lakeside Street  
Madison, Wisconsin 53715  
Phone: 608.255.3988  
Brian Munson [bmunson@vandewalle.com](mailto:bmunson@vandewalle.com)

**Existing Conditions:**

Existing Zoning: PUD: GDP (expired)

Proposed Zoning: PUD: GDP/SIP

Addresses:

6810 Milwaukee Street 0710-012-0401-6  
6834 Milwaukee Street 0710-012-0403-2  
1 Windstone Drive 0710-012-0601-2  
45 Windstone Drive 0710-012-0501-4  
6815 Advantage Drive 0710-012-0402-4

Aldermanic District: District 3:Alder Lemmer

Neighborhood Association: Sprecher Neighborhood Association

Neighborhood Plan: Sprecher Neighborhood Plan

Plan Designations: Medium Density Residential



Notifications/Meetings:	Alder Hall	December 20, 2018
	Alder Lemmer	May 15, 2019
	Sprecher Neighborhood	December 20, 2018
	City Staff Meetings	January 7, 2019
		March 26, 2019
	DAT Presentations	August 9, 2018
	UDC Informational Meeting: Neighborhood Meeting	February 24, 2019 January 7, 2019

**Legal Description:** Lots Two Hundred Thirty-Eight (238), Two Hundred Thirty-Nine (239), Two Hundred Forty (240), Two Hundred Forty-One (241) and Two Hundred Forty-Three (243), Second Addition to The Meadowlands in the City of Madison, Dane County, Wisconsin.

## **Proposed Zoning:**

**Proposed Uses:** 7 Townhomes  
216 Multi-Family Housing

**Permitted Uses:**

- 1.) Those that are stated as permitted uses in the TR-U1 zoning District.
- 2.) Uses accessory to permitted uses as listed above.

**Lot Area:** 7.0 acres

**Floor Area Ratio:**

- 1.) Maximum floor area ratio permitted as shown on approved plans
- 2.) Maximum building height shall be up to 4 stories or as shown on approved plans.

**Yard Requirements:** Yard areas will be provided as shown on approved plans

**Landscaping:** Site landscaping will be provided as shown on approved plans.

**Lighting:** Site lighting will be provided as shown on approved plans.

**Signage:** Signage will be allowed as per Chapter 31 of the Madison General Ordinances, as compared to the TR-U1 district, or signage will be provided as approved on the recorded plans.

**Family Definition:** The family definition of this PUD-SIP shall coincide with the definition given in Chapter 28.03(2) of the Madison General Ordinances for the TR-U1 District.



**Alterations and Revisions:** No alteration or revision of this planned unit development shall be permitted unless approved by the City Plan Commission; however, the Zoning Administrator may issue permits for minor alterations or additions which are approved by the Director of Planning and Development and the alderperson of the district and are compatible with the concept approved by the City Plan Commission.



**i i s:**

- Exhibit A: Alder & Neighborhood Notification
- Exhibit B: Location Map/Existing Conditions
- Exhibit C: Sprecher Neighborhood Plan
- Exhibit D: Meadowlands Neighborhood Master Plan
- Exhibit E: PUD:SIP Plans



## Brian Munson

---

From: Brian Munson  
Sent: Thursday, December 20, 2018 12:07 PM  
To: Alder Hall (district3@cityofmadison.com); dl\_mad@yahoo.com; 'rikberghammer@charter.net'  
Cc: 'Tim Parks'; Matt Gilhooly; Brian Munson  
Subject: Meadowlands Multifamily Proposal: Pending Notification

KCG Development is working towards a submittal for a new multi-family project north of Milwaukee Street & Wind Stone Drive. This area was previously approved for multi-family uses. We are working with Alder Hall to schedule a neighborhood meeting prior to submittal and are anticipating a submittal in February of next year.

We will share additional information on the exact timeline and Concept Plans with you as soon as possible.

Please feel free to contact me with any questions.

Thank you,

Brian Munson

VANDEWALLE & ASSOCIATES  
120 East Lakeside Street  
Madison, WI 53715  
608.255.3988

## Locator Maps

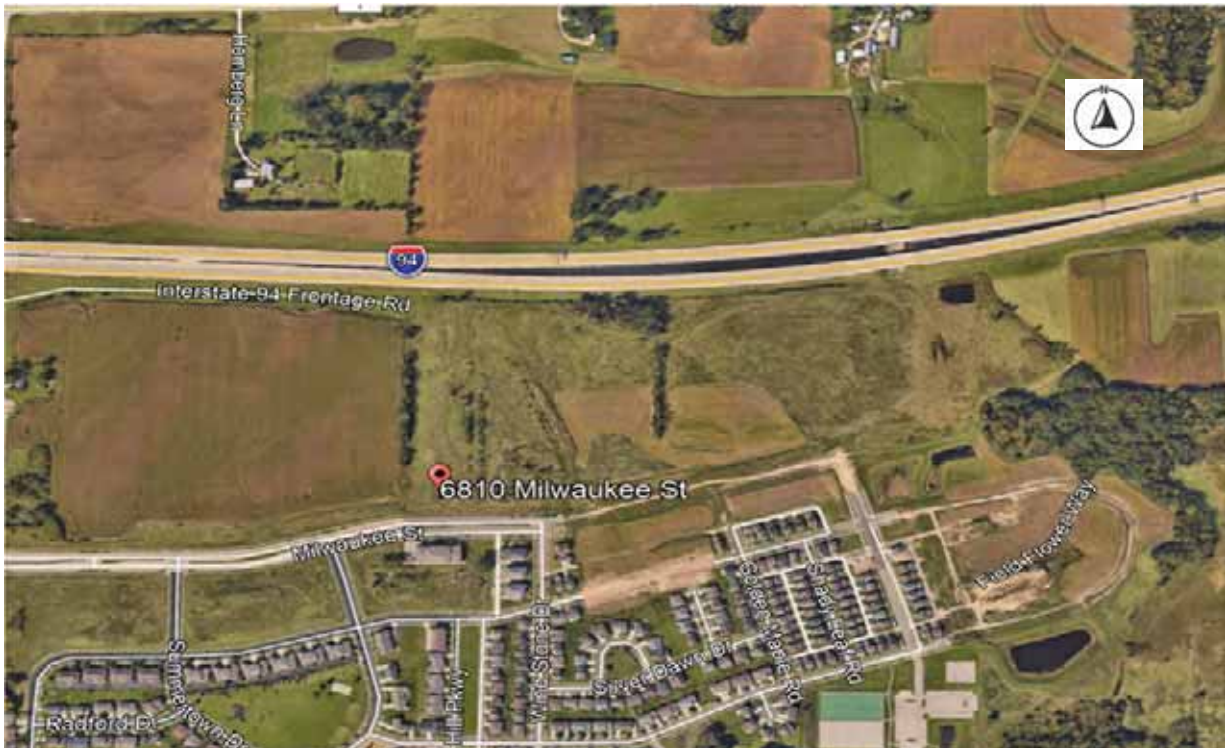
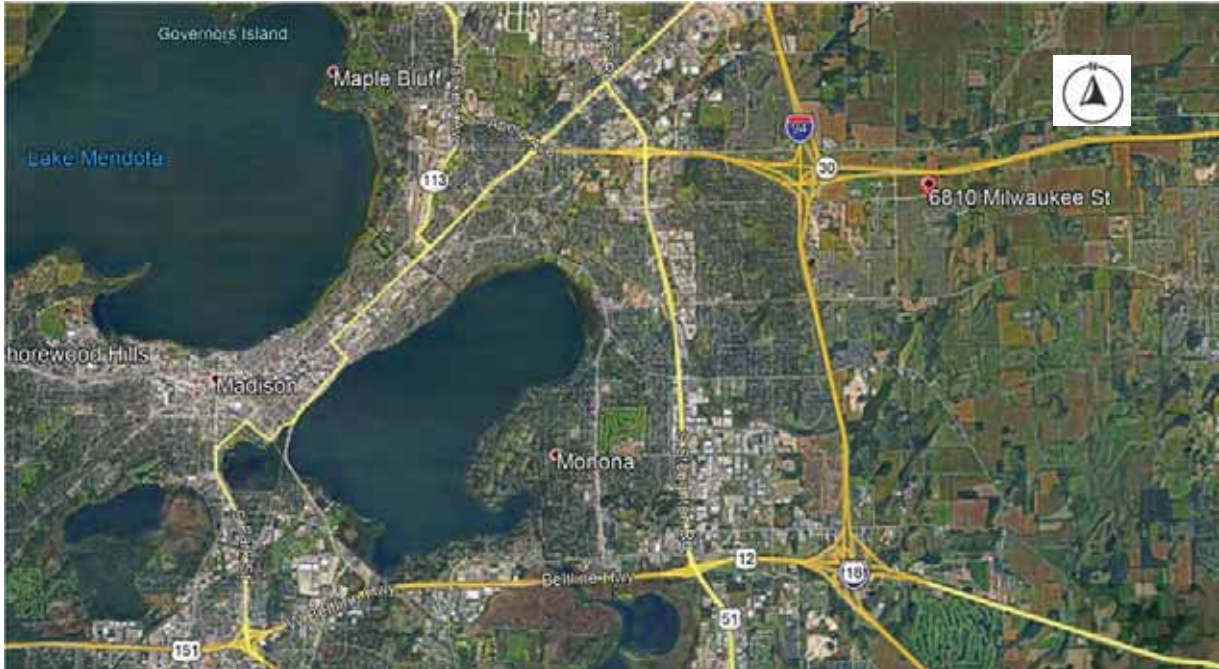

# Sprecher Neighborhood Development Plan

As Adopted January 1998, Amended May 1999, May 2001, November 2001, March 2005 & March 2012  
and implemented through subdivision and zoning approvals

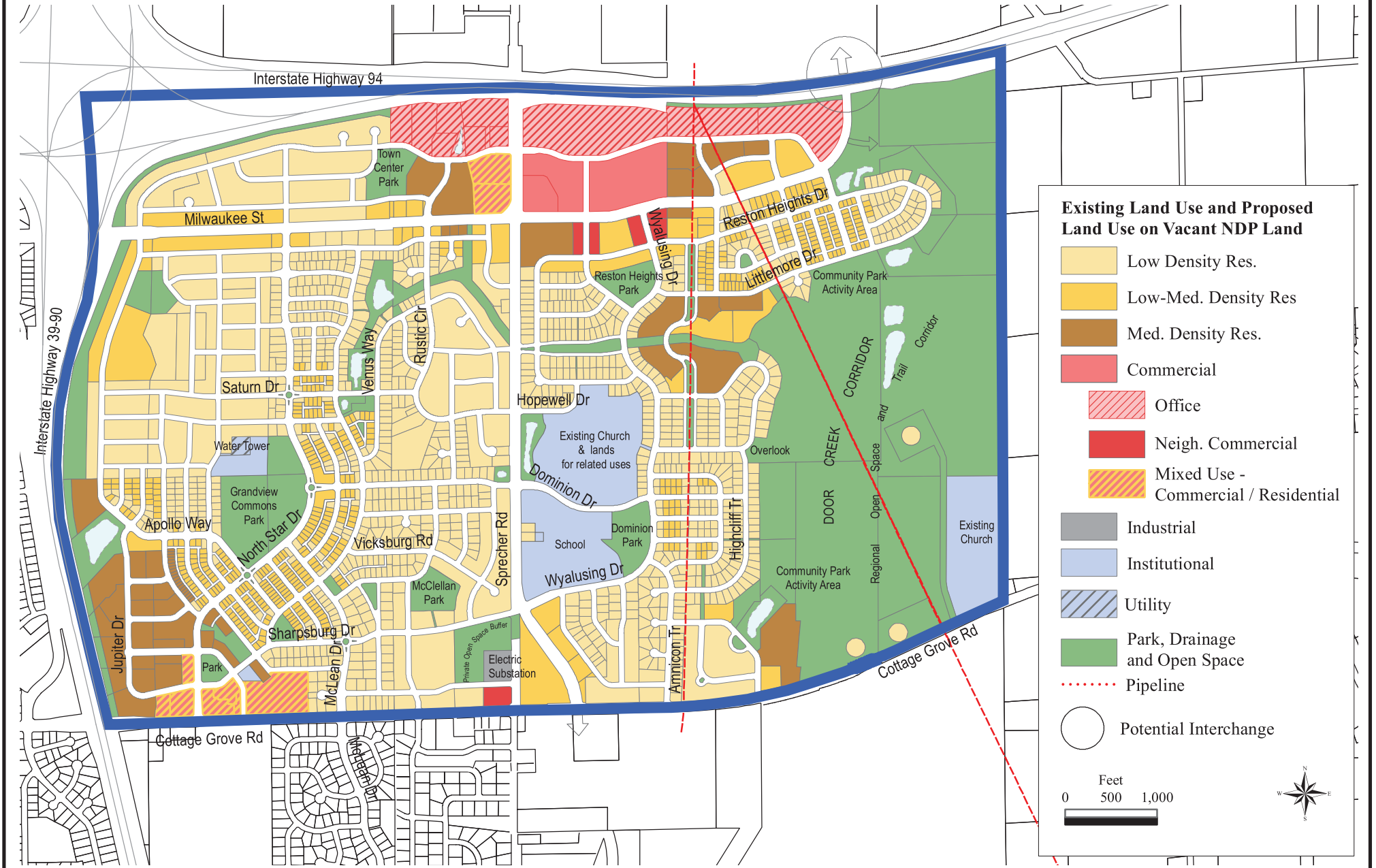



# THE MEADOWLANDS

Madison, Wisconsin

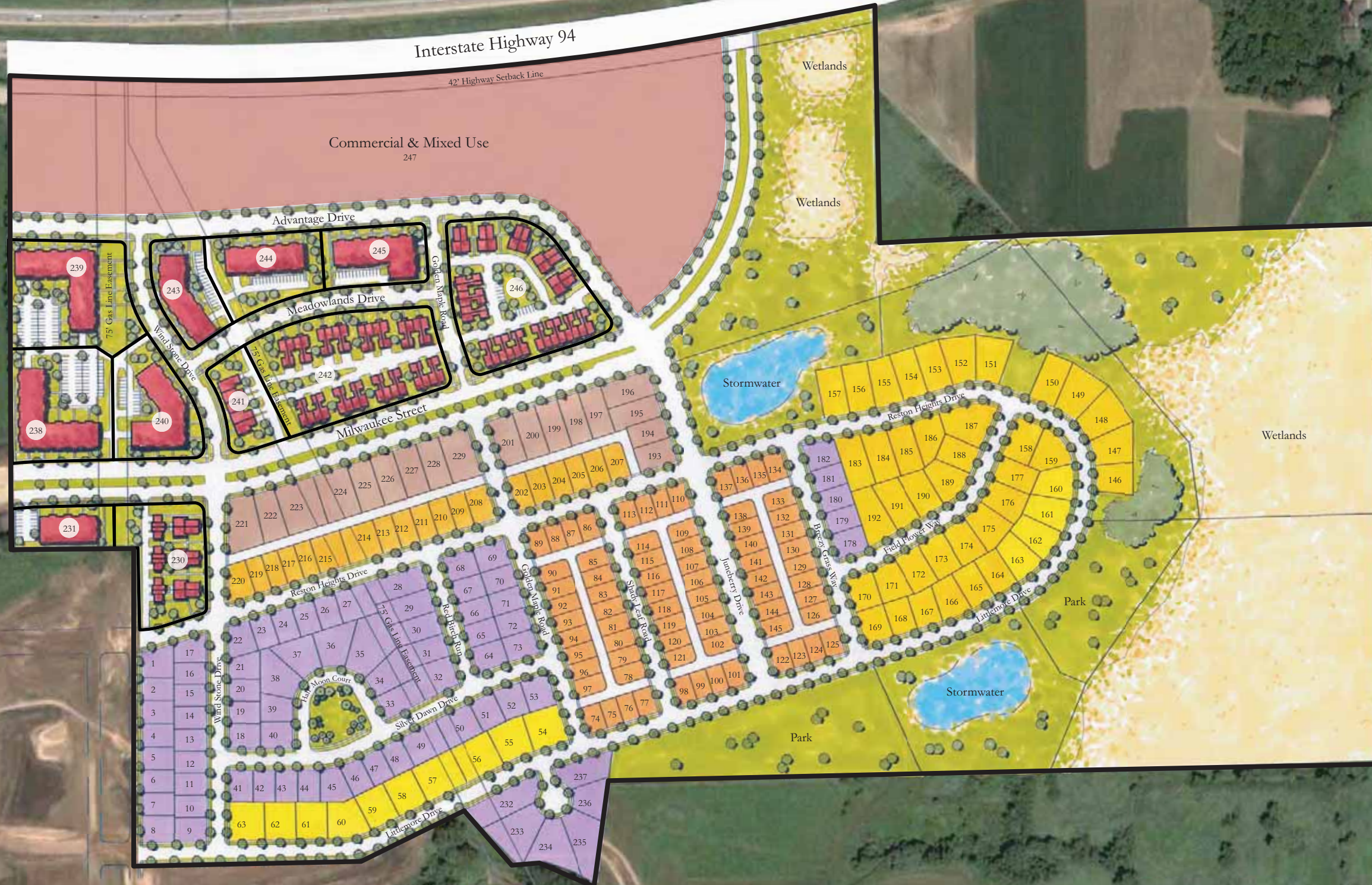

<b>Single Family (Alley Loaded)</b>	<b>91 Units</b>
45' x 80'	72 Units
45' x 95'	19 Units
<b>Single Family (Street Accessed)</b>	<b>126 Units</b>
59' x 85'	74 Units
69' x 100'	38 Units
80' x 100'	14 Units
<b>Multi-Family</b>	<b>341 Units</b>
Twin Homes	36 Units
Multi-Family Units	305 Units
<b>Total Units</b>	<b>558 Units</b>
<b>Parks/Open Space/Storm Water</b>	<b>~ 46 Acres</b>

## Multi-Family Lot Breakdowns

LOT #	Type of Units	#of Units	Lot Area
230	4-Unit Homes	12	62,563 sq. ft.
231	Condos	22	30,369 sq. ft.
238	Apartment	42	79,884 sq. ft.
239	Apartment	52	92,543 sq. ft.
240	Apartment	26	59,853 sq. ft.
241	Townhomes	5	33,550 sq. ft.
242	Townhomes	32	124,863 sq. ft.
243	Apartment	24	40,614 sq. ft.
244	Condo	24	55,830 sq. ft.
245	Apartment	26	42,576 sq. ft.
246	Townhomes	20	121,798 sq. ft.
	4-Unit Homes	20	
<b>Totals:</b>		<b>305</b>	<b>17.1 acres</b>

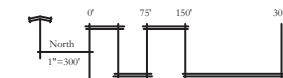

Revised: December 20, 2006  
 Vandewalle & Associates  
 © 2006

V:\Projects\2018118\_11293\MEADOWLANDS\118129\_2\AN.dwg, 5/22/2019 1:51:18 PM, barbara\_audcaud.plt (General Documentation) pcs, ANS (Titleblock D (4.00 x 22.00 inches)), 11

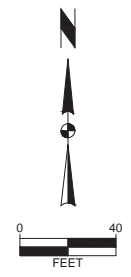
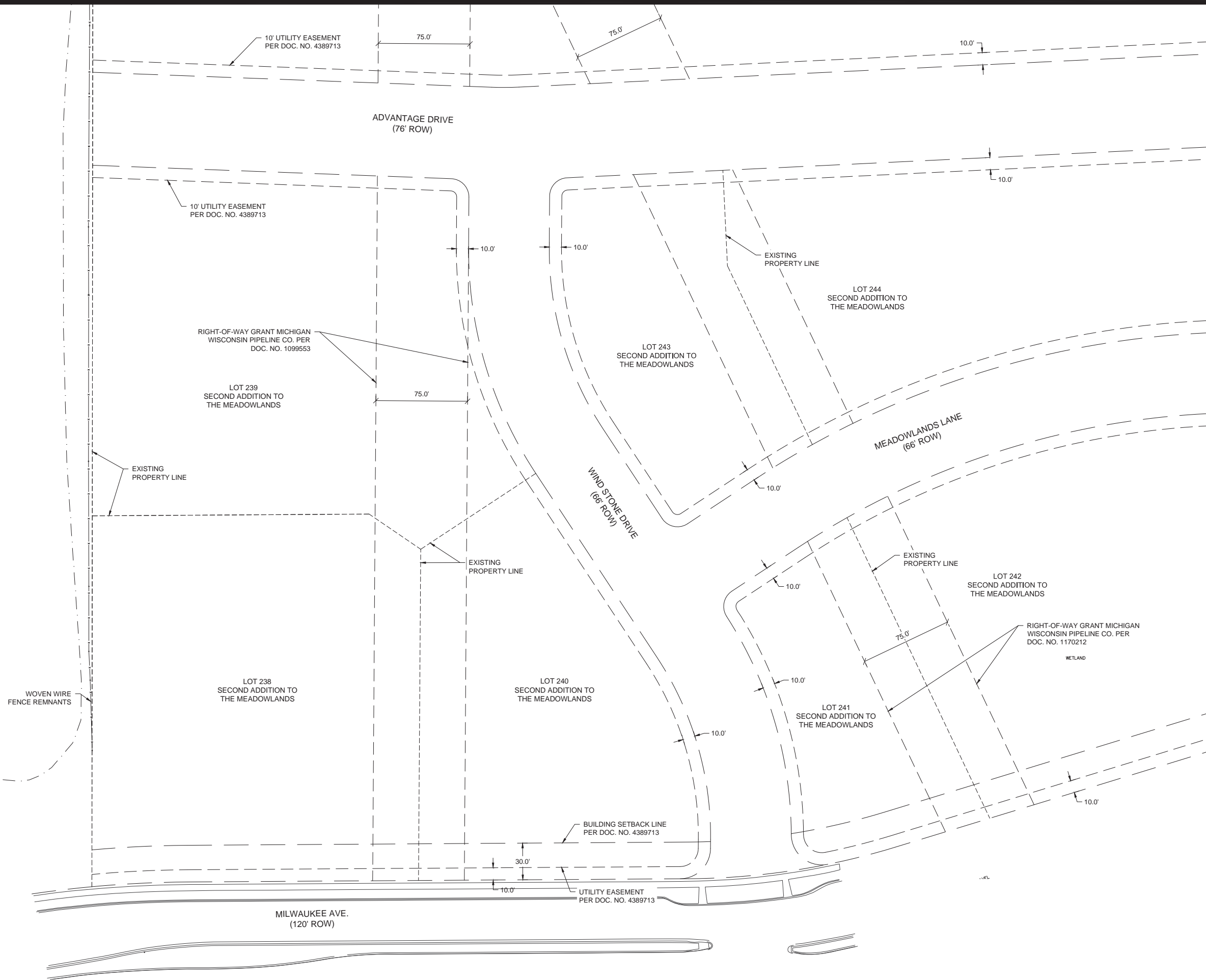

MARK	REVISION	BY	DATE
	Checked By: MLC		NOTED
	Engineer: BCA		Scale: 1" =
	Technician: BCA		Date: 01-07-2019
			Field Bk: Pg:

**THE MEADOWLANDS - PHASE 11**  
**EXISTING SITE PLAN**  
**MADISON, WI**  
**SNYDER & ASSOCIATES, INC.**  
 5010 VOGES ROAD  
 MADISON, WISCONSIN 53718  
 608-838-0444 | www.snyder-associates.com



W:\Projects\2018118\_11230\MEADOWLANDS\1181230\_SitePlan.dwg, 5/22/2019 1:35:59 PM, AutoCAD Plot (General Documentation) pcs, ANS (I) based D (4.00 x 22.00 inches), 1:1

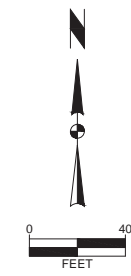
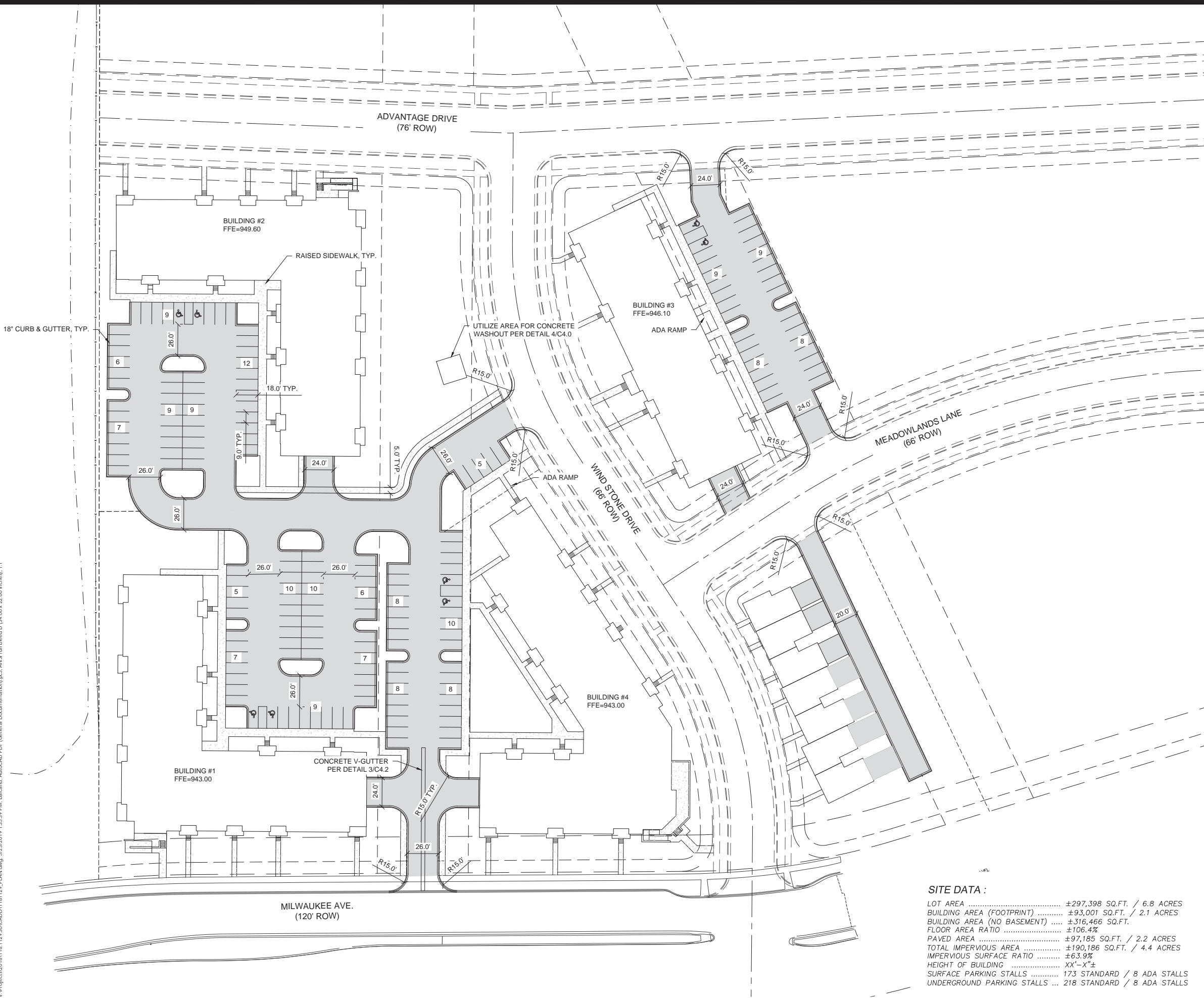

**LEGEND**

- ASPHALT
- CONCRETE

**NOTES**

1. STORMWATER MANAGEMENT REQUIREMENTS WILL BE MET UNDERGROUND.
2. CONTRACTOR SHALL REPLACE ALL SIDEWALK AND CURB AND GUTTER WHICH ABUTS THE PROPERTY WHICH IS DAMAGED BY THE CONSTRUCTION OF ANY SIDEWALK AND CURB AND GUTTER WHICH THE CITY ENGINEER DETERMINES NEEDS TO BE REPLACED BECAUSE IT IS NOT AT A DESIRABLE GRADE REGARDLESS OF WHETHER THE CONDITION EXISTED PRIOR TO BEGINNING CONSTRUCTION.
3. ALL WORK IN THE PUBLIC RIGHT-OF-WAY SHALL BE PERFORMED BY A CITY LICENSED CONTRACTOR.
4. ALL DAMAGE TO THE PAVEMENT ON UNIVERSITY AVENUE AND CAPITOL DRIVE, ADJACENT TO THIS DEVELOPMENT SHALL BE RESTORED IN ACCORDANCE WITH THE CITY OF MADISON'S PAVEMENT PATCHING CRITERIA.
5. THE CONTRACTOR SHALL CLOSE ALL ABANDONED DRIVEWAYS BY REPLACING THE CURB IN FRONT OF THE DRIVEWAYS AND RESTORING THE TERRACE WITH GRASS.

**GENERAL CONDITIONS**

1. THE CONTRACTOR SHALL NOTIFY THE OWNER TWO WORKING DAYS (48 HOURS) PRIOR TO THE START OF CONSTRUCTION.
2. THE CONTRACTOR SHALL INDEMNIFY THE OWNER, THE ENGINEER, AND THE MUNICIPALITY, THEIR AGENTS, ETC. FROM ALL LIABILITY INVOLVED WITH THE CONSTRUCTION, INSTALLATION, AND TESTING OF THE WORK ON THIS PROJECT.
3. SITE SAFETY SHALL BE THE SOLE RESPONSIBILITY OF THE CONTRACTOR.
4. THE CONTRACTOR IS RESPONSIBLE FOR VERIFYING SOIL CONDITIONS PRIOR TO COMMENCEMENT OF CONSTRUCTION.
5. THE CONTRACTOR IS RESPONSIBLE FOR EXAMINING ALL SITE CONDITIONS PRIOR TO COMMENCEMENT OF CONSTRUCTION AND SHALL COMPARE FIELD CONDITIONS WITH DRAWINGS.
6. THE CONTRACTOR SHALL OBTAIN AND PAY FOR ALL PERMITS REQUIRED FOR EXECUTION OF THE WORK. THE CONTRACTOR SHALL CONDUCT HIS WORK ACCORDING TO THE REQUIREMENTS OF THE PERMITS.
7. THE CONTRACTOR IS RESPONSIBLE FOR FIELD VERIFYING ALL UTILITY INFORMATION SHOWN ON THE PLANS PRIOR TO THE START OF CONSTRUCTION. THE CONTRACTOR SHALL CALL DIGGER'S HOTLINE AT 1-800-242-8511 TO NOTIFY THE UTILITIES OF HIS INTENTIONS, AND TO REQUEST FIELD LOCATING OF EXISTING UTILITIES.
8. CONTRACTOR IS ADVISED THAT ALL MUD AND DEBRIS MUST NOT BE DEPOSITED ONTO THE ADJACENT ROADWAYS PER THE REQUIREMENT OF THE MUNICIPALITY OR OTHER APPROPRIATE GOVERNMENT AGENCIES.
9. ANY ADJACENT PROPERTIES OR ROAD RIGHT-OF-WAYS WHICH ARE DAMAGED DURING CONSTRUCTION MUST BE RESTORED BY THE CONTRACTOR. THE COST OF THE RESTORATION IS CONSIDERED INCIDENTAL, AND SHOULD BE INCLUDED IN THE BID PRICES.
10. REMOVE SIDEWALKS TO THE NEAREST JOINT.
11. SAW CUTS SHALL BE FULL DEPTH PRIOR TO REMOVAL.
12. CITY FORESTRY WILL ISSUE A REMOVAL PERMIT FOR A 2" DIAMETER HORSECHESTNUT TREE DUE TO CONFLICT WITH PROPOSED DRIVEWAY LOCATED AT 3RD TREE ON UNIVERSITY AVE. FROM CAPITAL AVE. PLEASE CONTACT BRAD HOFMANN - BHOFMANN@CITYOFMADISON.COM OR 266-4816 TO OBTAIN STREET TREE REMOVAL PERMIT.

**SITE DATA :**

LOT AREA .....	±297,398 SQ.FT. / 6.8 ACRES
BUILDING AREA (FOOTPRINT) .....	±93,001 SQ.FT. / 2.1 ACRES
BUILDING AREA (NO BASEMENT) .....	±316,466 SQ.FT.
FLOOR AREA RATIO .....	±106.4%
PAVED AREA .....	±97,185 SQ.FT. / 2.2 ACRES
TOTAL IMPERVIOUS AREA .....	±190,186 SQ.FT. / 4.4 ACRES
IMPERVIOUS SURFACE RATIO .....	±63.9%
HEIGHT OF BUILDING .....	XX'-X"±
SURFACE PARKING STALLS .....	173 STANDARD / 8 ADA STALLS
UNDERGROUND PARKING STALLS ...	218 STANDARD / 8 ADA STALLS

MARK	REVISION	DATE	BY	NOTED

Checked By: MLC  
 Engineer: BCA  
 Technician: BCA  
 Date: 01-07-2019  
 Field Bk:  
 Pg:

118.1129.30

**MADISON, WI**

**THE MEADOWLANDS - PHASE 11**

**SITE PLAN**

**SNYDER & ASSOCIATES, INC.**

5010 VOGES ROAD  
 MADISON, WISCONSIN 53718  
 608-638-0444 | www.snyder-associates.com



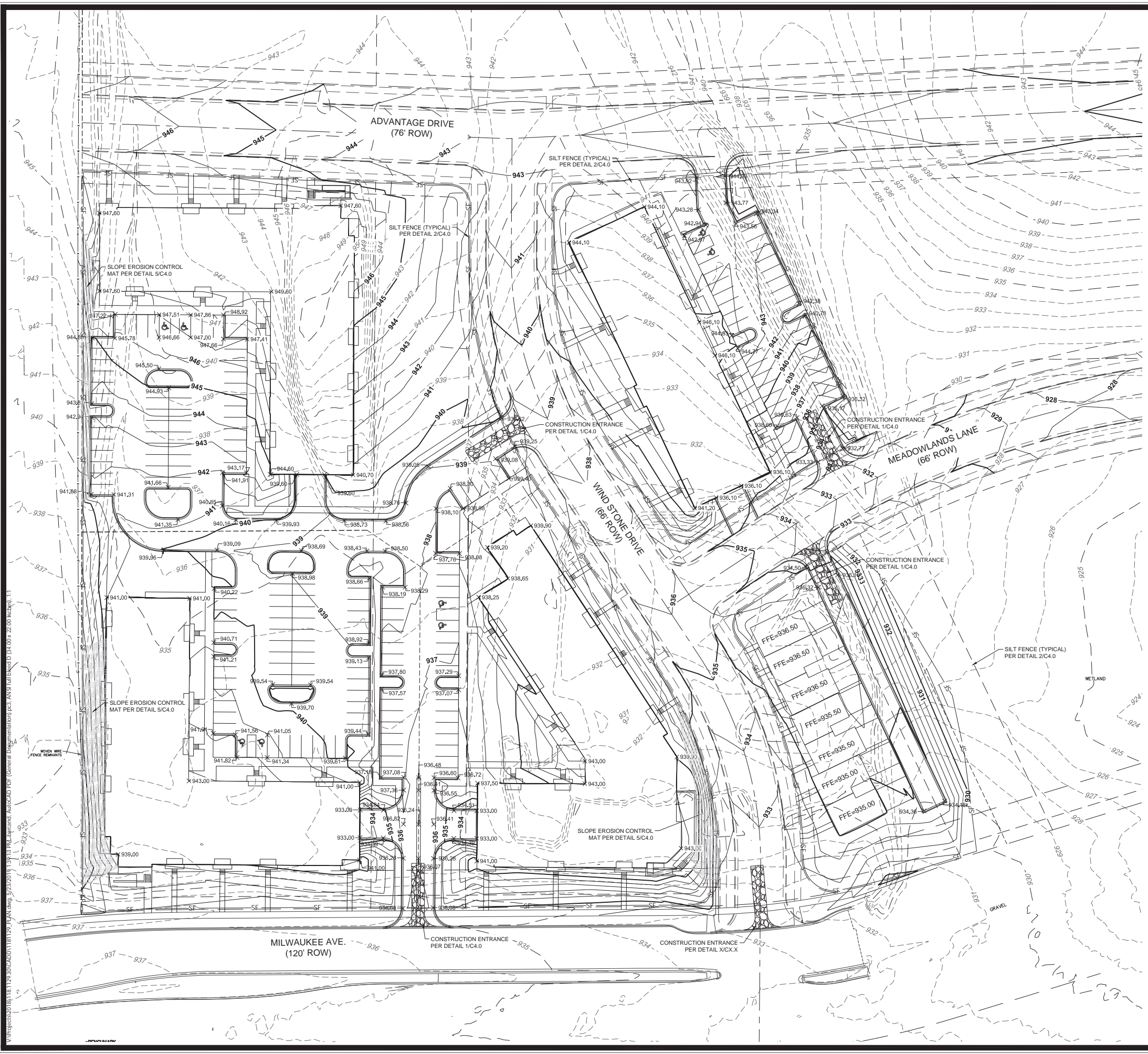

**EROSION CONTROL**

1. THE CONTRACTOR IS RESPONSIBLE FOR OBTAINING COPIES OF ALL PERMITS, INCLUDING WPDES DISCHARGE PERMITS (IF APPLICABLE). CONTRACTOR IS RESPONSIBLE FOR ABIDING BY ALL PERMIT REQUIREMENTS AND RESTRICTIONS.
2. ALL INSTALLATION AND MAINTENANCE OF EROSION CONTROL PRACTICES SHALL BE IN ACCORDANCE WITH THE APPLICABLE WISCONSIN DEPARTMENT OF NATURAL RESOURCES (WDNR) TECHNICAL STANDARD.
3. ALL EROSION CONTROL FACILITIES SHALL BE MAINTAINED THROUGHOUT THE DURATION OF THE PROJECT AND WARRANTY PERIOD.
4. ALL EROSION AND SEDIMENTATION CONTROL PRACTICES SHALL BE INSPECTED WEEKLY AND WITHIN 24 HOURS AFTER EVERY PRECIPITATION EVENT THAT PRODUCES 0.5 INCHES OF RAIN OR MORE DURING A 24 HOUR PERIOD. NEEDED REPAIRS WILL BE MADE IMMEDIATELY.
5. ALL DISTURBED GROUND LEFT INACTIVE FOR THIRTY DAYS OR MORE SHALL BE STABILIZED WITH TOPSOIL, SEED, AND MULCH IN ACCORDANCE WITH THE WDNR TECHNICAL STANDARDS 1059 AND 1058.
6. DISTURBED AREAS THAT CANNOT BE STABILIZED WITH A DENSE GROWTH OF VEGETATION BY SEEDING AND MULCHING DUE TO TEMPERATURE OR TIMING OF CONSTRUCTION, SHALL BE STABILIZED BY APPLYING EROSION MAT IN ACCORDANCE WITH WDNR TECHNICAL STANDARD 1050.
7. SEDIMENT WILL BE REMOVED FROM BEHIND THE SILT FENCE AND DITCH CHECKS WHEN IT REACHES HALF THE HEIGHT OF THE FENCE/BALE THE SILT FENCE AND DITCH CHECKS SHALL BE REPAIRED AS NECESSARY TO MAINTAIN A BARRIER.
8. THE CONTRACTOR IS RESPONSIBLE FOR INSTALLATION OF ANY ADDITIONAL EROSION CONTROL MEASURES NECESSARY TO PREVENT EROSION AND SEDIMENTATION. ALL DISTURBED AREAS ARE TO DRAIN TO APPROVED SEDIMENT CONTROL MEASURES AT ALL TIMES DURING SITE DEVELOPMENT UNTIL FINAL STABILIZATION IS ACHIEVED. DEPENDING ON HOW THE CONTRACTOR GRADES THE SITE, IT MAY BE NECESSARY TO INSTALL TEMPORARY SEDIMENT TRAPS IN VARIOUS LOCATIONS THROUGHOUT THE PROJECT. TEMPORARY SEDIMENT TRAPS SHALL BE DESIGNED, INSTALLED, AND MAINTAINED IN ACCORDANCE WITH WDNR TECHNICAL STANDARD 1063.
9. ANY SEDIMENT TRACKED ONTO A PUBLIC OR PRIVATE ROAD SHOULD BE REMOVED BY STREET CLEANING, NOT FLUSHING, BEFORE THE END OF EACH WORKING DAY.
10. DUST CONTROL SHALL BE PROVIDED AS NECESSARY IN ACCORDANCE WITH WDNR TECHNICAL STANDARD 1068.
11. ALL EROSION CONTROL MEASURES SHALL BE INSTALLED PRIOR TO THE START OF LAND DISTURBING ACTIVITIES.
12. REFER TO SPECIFICATION SECTIONS 31 20 00, 31 25 00, 32 91 19, AND 32 92 00.

**GRADING**

1. THE CONTRACTOR SHALL MAINTAIN SITE DRAINAGE THROUGHOUT CONSTRUCTION. THIS MAY INCLUDE THE EXCAVATION OF TEMPORARY DITCHES OR PUMPING TO ALLEVIATE WATER PONDING.
2. SILT FENCE AND OTHER EROSION CONTROL FACILITIES MUST BE INSTALLED PRIOR TO CONSTRUCTION OR ANY OTHER LAND DISTURBING ACTIVITY. THE CONTRACTOR SHALL BE RESPONSIBLE FOR REMOVING ALL EROSION CONTROL FACILITIES ONCE THE SITE HAS BEEN STABILIZED WITH VEGETATION AND THE APPROVAL OF THE GOVERNING AGENCY.
3. THE CONTRACTOR SHALL ASSUME SOLE RESPONSIBILITY FOR ALL GRADING, CUT AND FILL CALCULATIONS AND FOR ACTUAL LAND BALANCE, INCLUDING UTILITY TRENCH SPOIL. THE CONTRACTOR SHALL IMPORT OR EXPORT MATERIAL AS NECESSARY TO COMPLETE THE PROJECT.
4. GRADING SHALL CONSIST OF CLEARING AND GRUBBING EXISTING VEGETATION, STRIPPING TOPSOIL, REMOVAL OF EXISTING PAVEMENT OR FOUNDATIONS, IMPORTING OR EXPORTING MATERIAL TO ACHIEVE AND ON-SITE EARTHWORK BALANCE, GRADING THE BUILDING PADS AND PAVEMENT AREAS, SCARIFYING AND FINAL COMPACTION OF THE PAVEMENT SUBGRADE, AND PLACEMENT OF TOPSOIL.
5. NO FILL SHALL BE PLACED ON A WET OR SOFT SUBGRADE THE SUBGRADE SHALL BE PROOF-ROLLED AND INSPECTED BY THE ENGINEER BEFORE ANY MATERIAL IS PLACED.
6. REFER TO SPECIFICATION SECTIONS 31 20 00, 31 25 00, 32 91 19, AND 32 92 00.

THE MEADOWLANDS - PHASE 11  
GRADING PLAN



118.1129.30  
C 2.0

MADISON, WI

5010 VOGES ROAD  
MADISON, WISCONSIN 53718  
608-838-0444 | www.snyder-associates.com

**SNYDER & ASSOCIATES, INC.**

MARK	REVISION	DATE	BY
Engineer: BCA	Checked By: MLC	Scale: 1" =	NOTED
Technician: BCA	Date: 01-07-2019	Field Bk:	Pg:
			C 2.0

W:\Projects\2018118\_112303\MEADOWLANDS\11812303\_01.dwg, 5/14/2019 11:23:24 AM, bscgarcia, AUCG:AD, JPB (General Documentation) p33, ANS: Full Disc D (8400 x 22.00 inches), 1:1

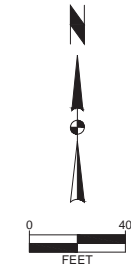
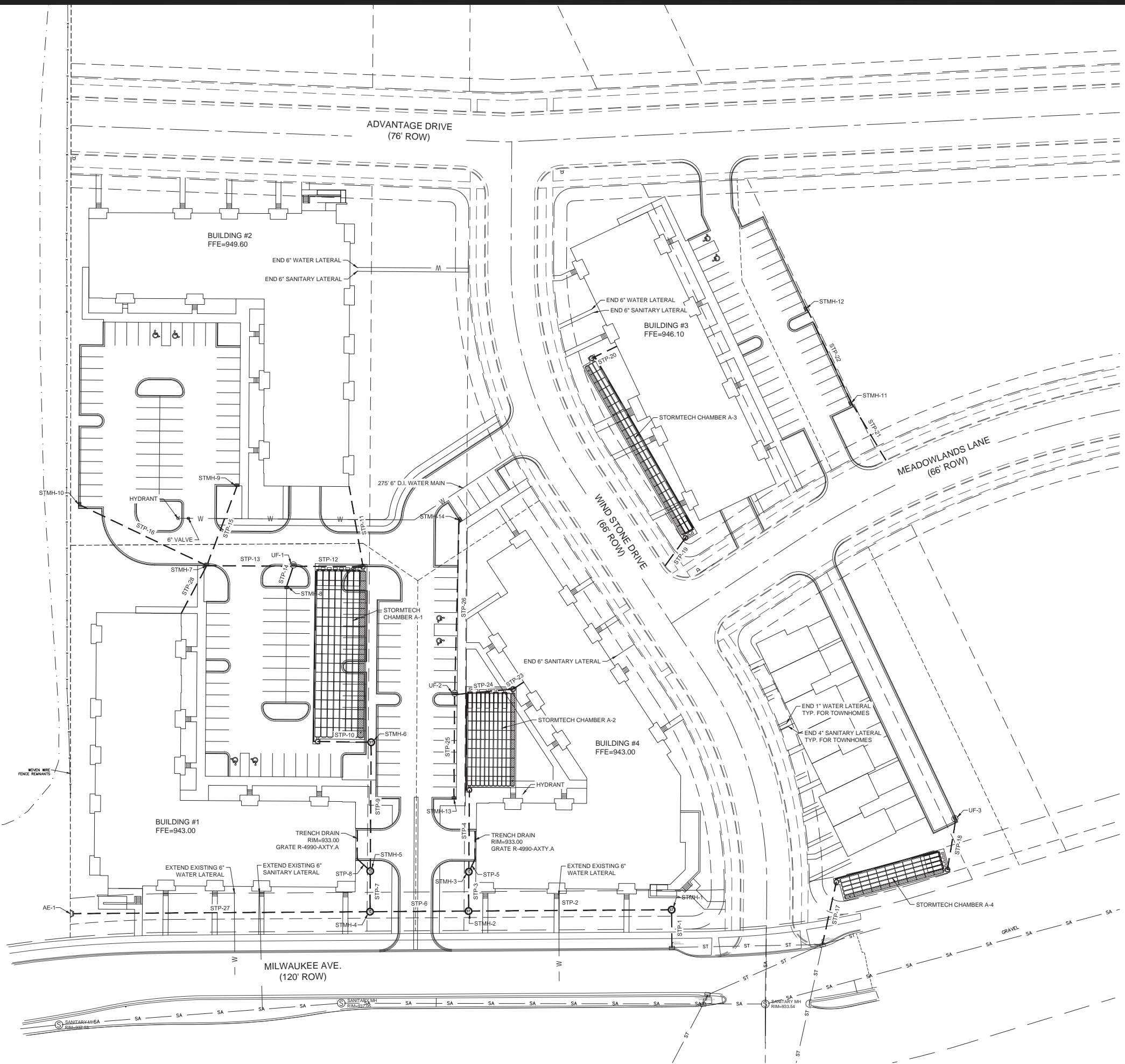

STRUCTURE TABLE					
STRUCT #	RIM EL	STRUCT TYPE	FRAME/GRATE	INVERTS IN	INVERTS OUT
AE-1	934.47	APRON ENDWALL	APRON ENDWALL	INV E = 932.39	
STMH-1	937.86	48" CONC STMH	R-1550	INV W = 929.56	INV S = 929.56
STMH-2	937.75	48" CONC STMH	R-1550	INV W = 930.35 INV N = 930.35	INV E = 930.35
STMH-3	937.55	48" CONC STMH	R-1550	INV N = 930.50 INV NE = 930.50	INV S = 930.50
STMH-4	938.23	48" CONC STMH	R-1550	INV N = 931.23	INV E = 930.73 INV W = 931.23
STMH-5	937.62	48" CONC STMH	R-1550	INV N = 931.39 INV NW = 931.39	INV S = 931.39
STMH-6	938.89	48" CONC STMH	R-1550	INV W = 932.48	INV S = 932.48
STMH-7	939.57	2' X 3' CI	R-3067	INV NW = 935.61 INV SW = 935.61 INV N = 935.61	INV E = 935.36
STMH-8	939.42	2' X 3' CI	R-3067		INV N = 936.16
STMH-9	943.03	2' X 3' CI	R-3067		INV S = 939.11
STMH-10	942.19	2' X 3' CI	R-3067		INV SE = 938.12
STMH-11	936.97	2' X 3' CI	R-1550	INV NW = 931.00	INV SE = 931.00
STMH-12	942.86	2' X 3' CI	R-1550		INV SE = 935.28
STMH-13	936.70	2' X 3' CI	R-3067		INV N = 932.66
STMH-14	938.90	2' X 3' CI	R-3067		INV S = 934.92
UF-1	939.14	UPFLOW FILTER	R-3067	INV W = 933.88 INV S = 935.64	INV E = 933.63
UF-2	937.22	UPFLOW FILTER	R-3067	INV N = 931.60 INV S = 931.60	INV E = 931.60
UF-3	934.65	UPFLOW FILTER	R-3067		INV S = 930.44

STORM PIPE TABLE									
PIPE NAME	PIPE TYPE	SIZE (IN.)	FROM	TO	LENGTH (FT)	START INV	END INV	SLOPE	
STP-1	CORRUGATED HDPE	30	EX INLET		29	929.56	929.41	0.50%	
STP-2	CORRUGATED HDPE	30	STMH-2	STMH-1	157	930.35	929.56	0.50%	
STP-3	CORRUGATED HDPE	15	STMH-3	STMH-2	30	930.50	930.35	0.50%	
STP-4	CORRUGATED HDPE	A-2		STMH-3	63	931.00	930.50	0.79%	
STP-5	CORRUGATED HDPE	TRENCH DRAIN		STMH-3	11	931.00	930.50	4.72%	
STP-6	CORRUGATED HDPE	30	STMH-4	STMH-2	76	930.73	930.35	0.50%	
STP-7	CORRUGATED HDPE	15	STMH-5	STMH-4	31	931.39	931.23	0.50%	
STP-8	CORRUGATED HDPE	TRENCH DRAIN		STMH-5	14	931.46	931.39	0.50%	
STP-9	CORRUGATED HDPE	15	STMH-6	STMH-5	100	932.48	931.39	1.09%	
STP-10	CORRUGATED HDPE	A-1		STMH-6	41	933.13	932.48	1.57%	
STP-11	CORRUGATED HDPE	BUILDING #2	A-1		63	933.76	933.13	1.00%	
STP-12	CORRUGATED HDPE	18	A-1		54	933.63	933.13	0.93%	
STP-13	CORRUGATED HDPE	15	STMH-7	UF-1	67	935.36	933.88	2.21%	
STP-14	CORRUGATED HDPE	12	STMH-8	UF-1	16	936.16	935.64	3.19%	
STP-15	CORRUGATED HDPE	12	STMH-9	STMH-7	66	939.11	935.61	5.34%	
STP-16	CORRUGATED HDPE	12	STMH-10	STMH-7	110	938.12	935.61	2.28%	
STP-17	CORRUGATED HDPE	A-4	EX INLET		50	928.25	927.75	1.01%	
STP-18	CORRUGATED HDPE	12	A-4		40	930.44	928.25	5.41%	
STP-19	CORRUGATED HDPE	A-3	EX INLET		27	933.00	932.79	0.79%	
STP-20	CORRUGATED HDPE	BUILDING #3	A-3		22	933.22	933.00	1.00%	
STP-21	CORRUGATED HDPE	12	EX INLET		52	931.00	927.82	6.16%	
STP-22	CORRUGATED HDPE	12	STMH-12	STMH-11	81	935.28	931.00	5.28%	
STP-23	CORRUGATED HDPE	BUILDING #4	A-2		10	931.10	931.00	1.00%	
STP-24	CORRUGATED HDPE	12	A-2		46	931.60	931.00	1.32%	
STP-25	CORRUGATED HDPE	12	STMH-13	UF-2	81	932.66	931.60	1.31%	
STP-26	CORRUGATED HDPE	12	STMH-14	UF-2	135	934.92	931.60	2.46%	
STP-27	CORRUGATED HDPE	24	STMH-4	AE-1	232	931.23	932.39	0.50%	
STP-28	CORRUGATED HDPE	BUILDING #1		STMH-7	42	935.95	935.61	0.81%	
TRENCH DRAIN 1	CORRUGATED HDPE	6			22	931.11	931.00	0.50%	
TRENCH DRAIN 2	CORRUGATED HDPE	6			22	931.57	931.46	0.50%	

THE MEADOWLANDS - PHASE 11  
UTILITY PLAN



MADISON, WI

5010 VOGES ROAD  
MADISON, WISCONSIN 53718  
608-638-0444 | www.snyder-associates.com

**SNYDER & ASSOCIATES, INC.**

MARK	REVISION	DATE	BY
Engineer: BCA	Checked By: MLC	Scale: 1" =	NOTED
Technician: BCA	Date: 01-07-2019	Field Bk:	Pg:

118.1129.30

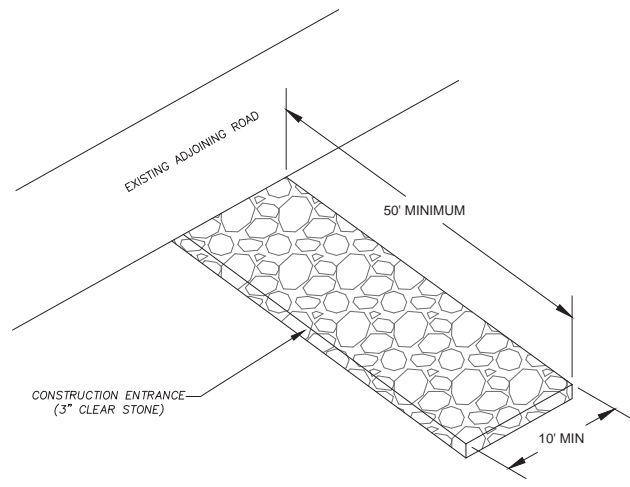

- GENERAL NOTES:**
- CONSTRUCTION ENTRANCE TO BE INSTALLED PRIOR TO ANY TRAFFIC LEAVING THE SITE.
  - THE AGGREGATE FOR THE CONSTRUCTION ENTRANCE SHALL BE 3 INCH CLEAR OR WASHED STONE.
  - AGGREGATE SHALL BE PLACED IN A LAYER AT LEAST 12 INCHES THICK.
  - THE CONSTRUCTION ENTRANCE SHALL BE UNDERLAIN WITH A WDOT TYPE HR OR FF GEOTEXTILE FABRIC TO PREVENT MIGRATION OF UNDERLYING SOIL INTO THE STONE.
  - SURFACE WATERS MUST BE PREVENTED FROM PASSING THROUGH THE CONSTRUCTION ENTRANCE. FLOWS SHALL BE DIVERTED AWAY FROM THE CONSTRUCTION ENTRANCE OR CONVEYED UNDER AND AROUND THEM BY USE OF A CULVERT, DIVERSION BERM OR OTHER PRACTICES AS APPROVED BY THE CONSTRUCTION ENGINEER.
  - CLEANING BY SCRAPING OR ADDING NEW STONE SHALL BE REQUIRED IF ENTRANCE BECOMES MORE THAN 50% COVERED BY TRACKED MUD.

**1 CONSTRUCTION ENTRANCE**  
SCALE: NTS

**GENERAL NOTES**  
MANUFACTURED ALTERNATIVES APPROVED AND LISTED ON THE WISDOT'S EROSION CONTROL PRODUCT ACCEPTABILITY LIST MAY BE SUBSTITUTED.

CLEANING SHALL BE REQUIRED WHEN SEDIMENT OR STANDING WATER IS WITHIN 6" OF OVERFLOW HOLES OR AS DIRECTED BY THE CONSTRUCTION ENGINEER.

WHEN REMOVING OR MAINTAINING INLET PROTECTION, CARE SHALL BE TAKEN SO THAT THE SEDIMENT TRAPPED ON THE GEOTEXTILE FABRIC DOES NOT FALL INTO THE INLET. ANY MATERIAL FALLING INTO THE INLET SHALL BE REMOVED IMMEDIATELY.

THE INSTALLED BAG SHALL HAVE A MINIMUM SIDE CLEARING BETWEEN THE INLET WALLS AND THE BAG, MEASURED AT THE BOTTOM OF THE OVERFLOW HOLES, OF 3". WHERE NECESSARY THE CONTRACTOR SHALL CINCH THE BAG USING PLASTIC ZIP TIES TO ACHIEVE THE 3" CLEARANCE. THE TIES SHALL BE PLACED AT A MAXIMUM OF 4" FROM THE BOTTOM OF THE BAG.

- TRIM EXCESS FABRIC IN THE FLOW LINE TO WITHIN 3" OF THE GRATE.
- FOR INLET PROTECTION WITH CURB BOX AN ADDITIONAL 18" OF FABRIC IS WRAPPED AROUND THE WOOD AND SECURED WITH STAPLES. THE WOOD SHALL NOT BLOCK THE ENTIRE HEIGHT OF THE CURB BOX OPENING.
- FLAP POCKETS SHALL BE LARGE ENOUGH TO ACCEPT WOOD 2X4.

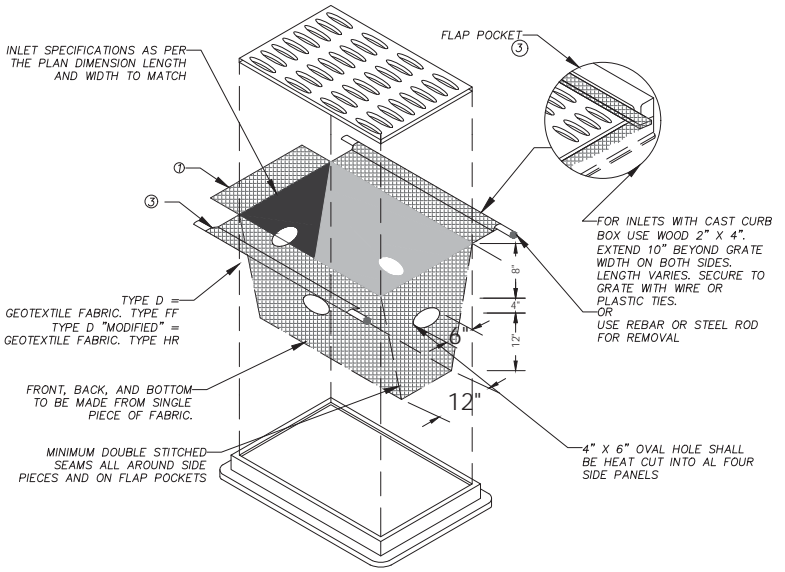

**3 INLET PROTECTION TYPE "D" DETAIL**  
SCALE: NTS

**EROSION CONTROL NOTES**

- THE CONTRACTOR IS RESPONSIBLE FOR OBTAINING COPIES OF ALL PERMITS, INCLUDING WISDNR WPDES DISCHARGE PERMIT (IF APPLICABLE), COUNTY AND LOCAL EROSION CONTROL PERMIT. CONTRACTOR IS RESPONSIBLE FOR ABIDING BY ALL PERMIT REQUIREMENTS AND RESTRICTIONS.
- ALL EROSION CONTROL MEASURES SHALL BE INSTALLED PRIOR TO LAND DISTURBING ACTIVITIES.
- ALL INSTALLATION AND MAINTENANCE OF EROSION CONTROL PRACTICES SHALL BE IN ACCORDANCE WITH THE APPLICABLE WISCONSIN DEPARTMENT OF NATURAL RESOURCES (WDNR) TECHNICAL STANDARD, FOUND AT: [http://dnr.wi.gov/topic/stormwater/standards/const\\_standards.html](http://dnr.wi.gov/topic/stormwater/standards/const_standards.html) OR THE WISCONSIN CONSTRUCTION SITE BEST MANAGEMENT PRACTICE HANDBOOK IF A TECHNICAL STANDARD IS NOT AVAILABLE.
- ALL EROSION CONTROL FACILITIES SHALL BE MAINTAINED THROUGHOUT THE DURATION OF THE PROJECT AND WARRANTY PERIOD IN CONFORMANCE WITH ALL APPLICABLE PERMITS ISSUED FOR THE PROJECT.
- ALL EROSION AND SEDIMENTATION CONTROL PRACTICES SHALL BE INSPECTED WEEKLY AND WITHIN 24 HOURS AFTER EVERY PRECIPITATION EVENT THAT PRODUCES 0.5 INCHES OF RAIN OR MORE DURING A 24 HOUR PERIOD. REPAIRS SHALL BE MADE IMMEDIATELY TO EROSION CONTROL PRACTICES AS NECESSARY.
- TEMPORARY STOCKPILES SHALL BE STABILIZED IF NOT REMOVED IN 10 DAYS. PERIMETER CONTROL ON THE DOWNHILL SIDE SHALL BE IN PLACE AT ALL TIMES (SILT FENCE OR APPROVED EQUAL).
- TEMPORARY SEED MIXTURE SHALL CONFORM TO 630.2.1.5.1.4 OF THE WISDOT STANDARD. SPECIFICATIONS USE WINTER WHEAT OR RYE FOR FALL PLANTINGS STARTED AFTER SEPTEMBER 1.
- DISTURBED AREAS THAT CANNOT BE STABILIZED WITH A DENSE GROWTH OF VEGETATION BY SEEDING AND MULCHING DUE TO TEMPERATURE OR TIMING OF CONSTRUCTION, SHALL BE STABILIZED BY APPLYING ANIONIC POLYACRYLAMIDE (PAM) IN ACCORDANCE WITH WDNR TECHNICAL STANDARD 1050.
- SEDIMENT SHALL BE REMOVED FROM THE SEDIMENT BASINS TO MAINTAIN A THREE FOOT DEPTH OF TREATMENT, MEASURED BELOW THE NORMAL WATER ELEVATION. SEDIMENT WILL BE REMOVED FROM THE DIVERSION DITCHES WHEN IT REACHES HALF THE HEIGHT OF THE DITCH. SEDIMENT WILL BE REMOVED FROM BEHIND THE SILT FENCE AND DITCH CHECKS WHEN IT REACHES HALF THE HEIGHT OF THE FENCE/BALE. THE SILT FENCE AND DITCH CHECKS SHALL BE REPAIRED AS NECESSARY TO MAINTAIN A BARRIER.
- ALL WATER FROM CONSTRUCTION DEWATERING SHALL BE TREATED IN ACCORDANCE WITH WDNR TECHNICAL STANDARD 1061 PRIOR TO DISCHARGE TO WATERS OF THE STATE, WETLANDS, OR OFFSITE.
- THE CONTRACTOR IS RESPONSIBLE FOR INSTALLATION OF ANY ADDITIONAL EROSION CONTROL MEASURES NECESSARY TO PREVENT EROSION AND SEDIMENTATION. ALL DISTURBED AREAS ARE TO DRAIN TO APPROVED SEDIMENT CONTROL MEASURES AT ALL TIMES DURING SITE DEVELOPMENT UNTIL FINAL STABILIZATION IS ACHIEVED. DEPENDING ON HOW THE CONTRACTOR GRADES THE SITE, IT MAY BE NECESSARY TO INSTALL TEMPORARY EROSION CONTROL AND/OR SEDIMENT TRAPS IN VARIOUS LOCATIONS THROUGHOUT THE PROJECT. TEMPORARY SEDIMENT TRAPS SHALL BE DESIGNED, INSTALLED, AND MAINTAINED IN ACCORDANCE WITH WDNR TECHNICAL STANDARD 1063.
- TRACKED MATERIAL TO ADJACENT STREETS SHALL BE COLLECTED AT THE END OF EACH WORKING DAY OR AS REQUIRED BY THE LOCAL MUNICIPALITY.
- DUST CONTROL SHALL BE PROVIDED AS NECESSARY IN ACCORDANCE WITH WDNR TECHNICAL STANDARD 106B.
- FINAL STABILIZATION OF LANDSCAPED AREAS SHALL BE IN ACCORDANCE WITH THE APPROVED LANDSCAPE PLAN.
- ALL SEEDED AREAS WILL BE FERTILIZED, RESEED AS NECESSARY, AND MULCHED ACCORDING TO SPECIFICATIONS IN THE APPROVED LANDSCAPE PLAN TO MAINTAIN A VIGOROUS DENSE VEGETATIVE COVER.
- THE CONTRACTOR IS RESPONSIBLE FOR PROVIDING ALL EROSION CONTROL FACILITIES AND MEASURES NECESSARY TO CONTROL EROSION AND SEDIMENTATION AT THE PROJECT SITE. THESE FACILITIES AND MEASURES MAY OR MAY NOT BE SHOWN ON THE DRAWINGS AND THEIR ABSENCE ON THE DRAWINGS DOES NOT ALLEVIATE THE CONTRACTOR FROM PROVIDING THEM. ANY MEASURES AND FACILITIES SHOWN ON THE DRAWINGS ARE THE MINIMUM ACTIONS REQUIRED.
- ERODED MATERIAL THAT HAS LEFT THE CONSTRUCTION SITE SHALL BE COLLECTED AND RETURNED TO THE SITE BY THE CONTRACTOR.
- AFTER FINAL VEGETATION IS ESTABLISHED, REMOVE ALL EROSION CONTROL FACILITIES. RESTORE AREAS DISTURBED BY THE REMOVALS.
- KEEP A COPY OF THE CURRENT EROSION CONTROL PLAN ON SITE THROUGHOUT THE DURATION OF THE PROJECT.
- COMPLETE AND STABILIZE SEDIMENT BASINS/TRAPS PRIOR TO MASS LAND DISTURBANCE TO CONTROL RUNOFF DURING CONSTRUCTION. REMOVE SEDIMENT AS NEEDED TO MAINTAIN 3 FEET OF DEPTH TO THE OUTLET, AND PROPERLY DISPOSE OF SEDIMENT REMOVED DURING MAINTENANCE. CONSTRUCT AND MAINTAIN THE SEDIMENT BASIN PER WDNR TECHNICAL STANDARDS.
- PROPERLY DISPOSE OF ALL WASTE AND UNUSED BUILDING MATERIALS (INCLUDING GARBAGE, DEBRIS, CLEANING WASTES, OR OTHER CONSTRUCTION MATERIALS) AND DO NOT ALLOW THESE MATERIALS TO BE CARRIED BY RUNOFF INTO THE RECEIVING CHANNEL.
- MAKE PROVISIONS FOR WATERING DURING THE FIRST 8 WEEKS FOLLOWING SEEDING OR PLANTING OF DISTURBED AREAS WHENEVER MORE THAN 7 CONSECUTIVE DAYS OF DRY WEATHER OCCUR.

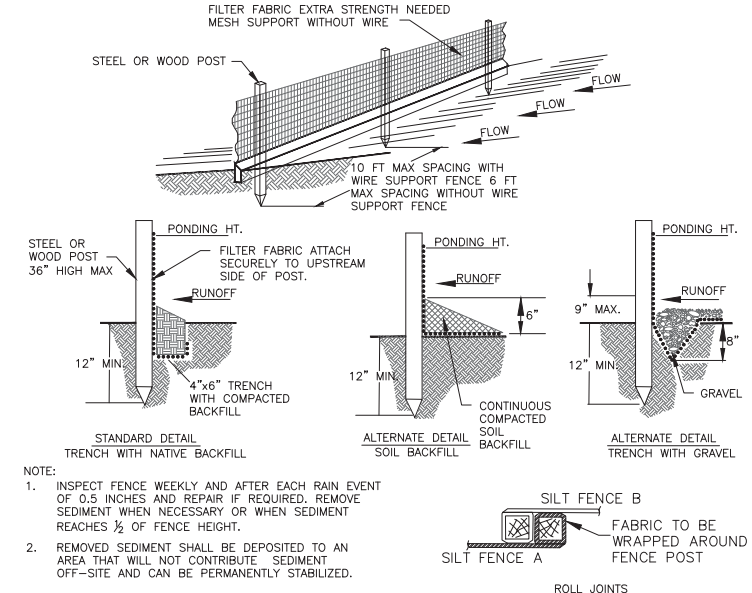

- NOTE:**
- INSPECT FENCE WEEKLY AND AFTER EACH RAIN EVENT OF 0.5 INCHES AND REPAIR IF REQUIRED. REMOVE SEDIMENT WHEN NECESSARY OR WHEN SEDIMENT REACHES 1/2 OF FENCE HEIGHT.
  - REMOVED SEDIMENT SHALL BE DEPOSITED TO AN AREA THAT WILL NOT CONTRIBUTE SEDIMENT OFF-SITE AND CAN BE PERMANENTLY STABILIZED.
  - SILT FENCE SHALL BE PLACED ON SLOPE CONTOURS TO MAXIMIZE PONDING EFFICIENCY.
  - SILT FENCE SHALL BE INSTALLED AND MAINTAINED IN ACCORDANCE WITH WDNR TECHNICAL STANDARD 1056.

**2 SILT FENCE DETAIL**  
SCALE: NTS

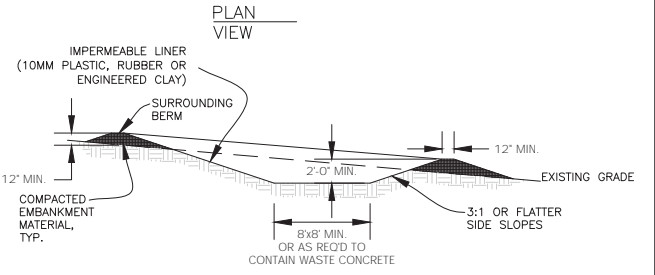
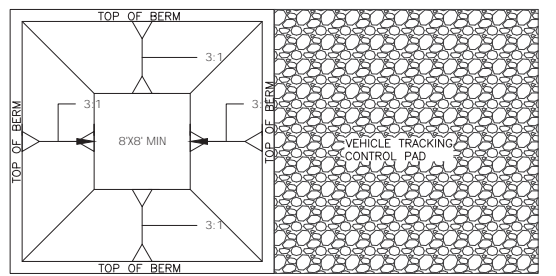

- CONCRETE WASHOUT AREA INSTALLATION NOTES**
- SEE EROSION CONTROL PLAN FOR LOCATIONS OF CONCRETE WASHOUT AREA(S). TO BE PLACED A MIN. OF 50' FROM DRAINAGEWAYS, BODIES OF WATER, AND INLETS.)
  - THE CONCRETE WASHOUT AREA(S) SHALL BE INSTALLED PRIOR TO ANY CONCRETE PLACEMENT ON SITE.
  - VEHICLE TRACKING CONTROL PAD IS REQ'D AT THE ACCESS POINT(S).
  - SIGNS SHALL BE PLACED AT THE CONSTRUCTION ENTRANCE, AT THE WASHOUT AREA(S), AND ELSEWHERE AS NECESSARY TO CLEARLY INDICATE THE LOCATION OF THE CONCRETE WASHOUT AREAS TO OPERATORS OF CONCRETE TRUCKS AND PUMP RIGS.
  - EXCAVATED MATERIAL SHALL BE UTILIZED IN PERIMETER BERM CONSTRUCTION.
- CONCRETE WASHOUT AREA MAINTENANCE NOTES**
- THE CONCRETE WASHOUT AREA SHALL BE REPAIRED AND ENLARGED OR CLEANED OUT AS NECESSARY TO MAINTAIN CAPACITY FOR WASTED CONCRETE
  - AT THE END OF CONSTRUCTION, ALL CONCRETE SHALL BE REMOVED FROM SITE AND DISPOSED OF AT AN APPROVED WASTE SITE.
  - WHEN CONCRETE WASHOUT AREA(S) IS REMOVED, THE DISTURBED AREA SHALL BE STABILIZED PER SITE EROSION CONTROL MEASURES.
  - INSPECT WEEKLY AND DURING AND AFTER ALL STORM EVENTS. CLEAN-OUT OR COVER WASHOUT AREA PRIOR TO PREDICTED STORM EVENTS TO PREVENT OVER-FLOW.

**4 CONCRETE WASHOUT AREA**  
SCALE: NTS

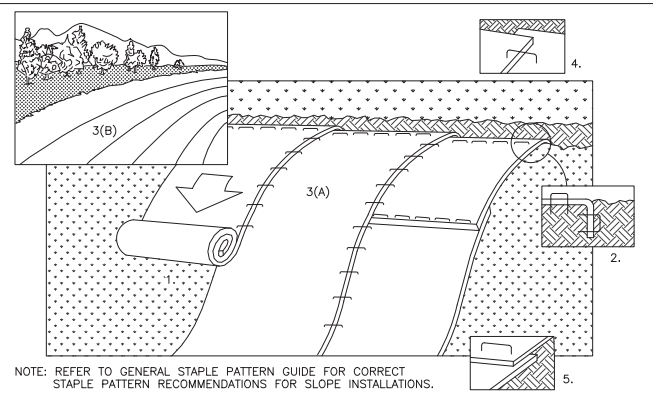

- NOTE:** REFER TO GENERAL STAPLE PATTERN GUIDE FOR CORRECT STAPLE PATTERN RECOMMENDATIONS FOR SLOPE INSTALLATIONS.
- PREPARE SOIL BEFORE INSTALLING BLANKETS, INCLUDING APPLICATION OF FERTILIZER AND SEED. NOTE: WHEN USING CELL-0-SEED DO NOT SEED PREPARED AREA. CELL-0-SEED MUST BE INSTALLED WITH PAPER SIDE DOWN.
  - BEGIN AT THE TOP OF THE SLOPE BY ANCHORING THE BLANKET IN 6" DEEP X 6" WIDE TRENCH. BACKFILL AND COMPACT THE TRENCH AFTER STAPLING.
  - ROLL THE BLANKETS (A.) DOWN OR (B.) HORIZONTALLY ACROSS THE SLOPE.
  - THE EDGES OF PARALLEL BLANKETS MUST BE STAPLED WITH APPROXIMATELY 2" OVERLAP.
  - WHEN BLANKETS MUST BE SPLICED DOWN THE SLOPE, PLACE BLANKETS END OVER END (SINGLE STYLE) WITH APPROXIMATELY 4" OVERLAP. STAPLE THROUGH OVERLAPPED AREA, APPROXIMATELY 12" APART.
  - ALL BLANKETS MUST BE SECURELY FASTENED TO THE SLOPE BY PLACING STAPLES/STAKES IN APPROPRIATE LOCATIONS AS RECOMMENDED BY THE MANUFACTURER.
  - EROSION MAT SHALL BE INSTALLED AND MAINTAINED IN ACCORDANCE WITH WDNR TECHNICAL STANDARD # 1052.

**5 EROSION CONTROL MAT - SLOPE INSTALLATION**  
SCALE: NTS



MARK	REVISION	DATE	BY	NOTED
Engineer: BCA	Checked By: MLC	Date: 01-07-2019	Scale: 1" = 1'	Field Bk:
Technician: BCA				Pg: C 4.0
				118.1129.30

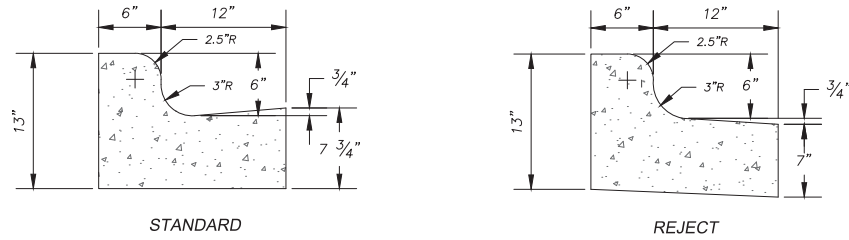

**NOTES:**

1. LATERAL CONTRACTION JOINTS SHALL BE PLACED AT INTERVALS OF NOT MORE THAN 15' NOR LESS THAN 6' IN LENGTH. THE JOINTS SHALL BE A MINIMUM OF 3" IN DEPTH. EXPANSION JOINTS SHALL BE PLACED TRANSVERSELY AT RADIUS POINTS ON CURVES OF RADIUS 200' OR LESS, AND AT ANGLE POINTS, OR AS DIRECTED BY THE ENGINEER.
2. THE EXPANSION JOINT SHALL BE A ONE PIECE ASPHALTIC MATERIAL HAVING THE SAME DIMENSIONS AS CURB & GUTTER AT THAT STATION AND BE 1/2" THICK. IN ALL CASES, CONCRETE CURB & GUTTER SHALL BE PLACED ON THOROUGHLY COMPACTED CRUSHED STONE.

**1** CONCRETE CURB & GUTTER  
C4.1 SCALE: NTS

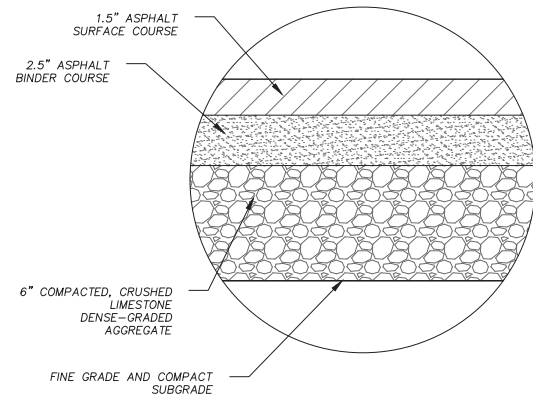

**2** LIGHT DUTY ASPHALT PAVING DETAIL  
C4.1 SCALE: NTS

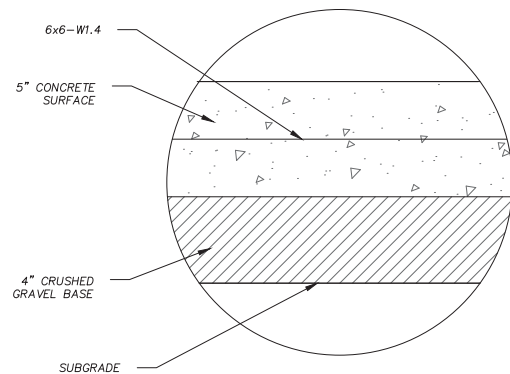

**3** DUMPSTER PAD LOADING CONCRETE DETAIL  
C4.1 SCALE: NTS

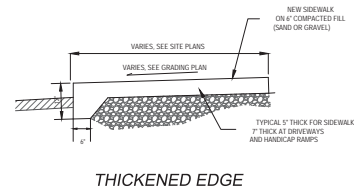

THICKENED EDGE

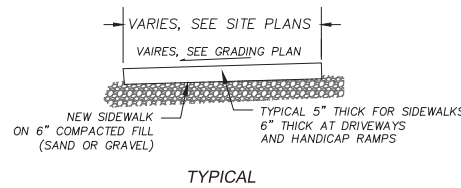

TYPICAL

**4** CONCRETE SIDEWALK DETAILS  
C4.1 SCALE: NTS

**PAVEMENT AND CURB NOTES**

1. THE IMPROVEMENTS SHALL BE CONSTRUCTED ACCORDING TO THE WISCONSIN D.O. T. STANDARD SPECIFICATIONS FOR HIGHWAY AND STRUCTURE CONSTRUCTION, LA TEST EDITION, AND THE LOCAL ORDINANCES AND SPECIFICATIONS.
2. PAVING SHALL CONSIST OF FINE GRADING PAVEMENT AREAS, INSTALLATION OF CRUSHED STONE BASE, CONCRETE AND/OR BITUMINOUS PAVEMENT, PAVEMENT MARKING, AND CLEANUP. ALL MATERIALS SHALL BE PROVIDED BY THE CONTRACTOR.
3. AGGREGATES USED IN THE CRUSHED AGGREGATE BASE SHALL BE (\*-INCH) DENSE GRADED BASE IN ACCORDANCE WITH SUBSECTION 305.2.2 OF THE STANDARD SPECIFICATIONS.
4. HOT MIX ASPHALT PAVEMENT (HMA) SHALL BE SUPERPAVE (E-\*\*) IN ACCORDANCE WITH SECTION 460 OF THE STANDARD SPECIFICATIONS.
5. ASPHALTIC MATERIALS SHALL BE PERFORMANCE GRADED (PG) BINDERS IN ACCORDANCE WITH SECTION 455 OF THE STANDARD SPECIFICATIONS. UPPER LAYERS SHALL BE PG(\*\*\*), AND LOWER LAYERS SHALL BE PG(\*\*\*).
6. AGGREGATES USED IN THE HMA SHALL BE IN ACCORDANCE WITH SUBSECTION 460.2.2.3 OF THE STANDARD SPECIFICATIONS. THE NOMINAL AGGREGATE SIZE FOR THE UPPER LAYER PAVEMENT SHALL BE (\*\*\*\*), AND THE LOWER LAYER PAVEMENT SHALL BE (\*\*\*\*).
7. TACK COAT SHALL BE IN ACCORDANCE WITH SUBSECTION 455.2.5 OF THE STANDARD SPECIFICATIONS. THE RATE OF APPLICATION SHALL BE 0.025 GAL/SY.
8. CONCRETE FOR CURB, DRIVEWAY, WALKS AND NON-FLOOR SLABS SHALL BE GRADE A (OR GRADE A2 IF PLACING BY SLIP-FORMED PROCESS) AIR ENTRAINED IN ACCORDANCE WITH SECTION 501 FOR THE STANDARD SPECIFICATIONS, WITH A MINIMUM 28 DAY COMPRESSIVE STRENGTH OF 3,500 PSI.
9. CONCRETE CONSTRUCTION SHALL BE IN ACCORDANCE WITH THE FOLLOWING SECTIONS OF THE STANDARD SPECIFICATIONS:  
SECTION 415 FOR CONCRETE PAVEMENT  
SECTION 601 FOR CONCRETE CURB AND GUTTER  
SECTION 602 FOR CONCRETE SIDEWALKS.
10. ALL FINISHED CONCRETE SHALL BE COVERED WITH A LIQUID CURING COMPOUND CONFORMING TO AASHTO M 148, TYPE 2, IN ACCORDANCE WITH SECTION 415 OF THE STANDARD SPECIFICATIONS.
11. PAVEMENT MARKINGS SHALL BE PAINT IN ACCORDANCE WITH SECTION 646 OF THE STANDARD SPECIFICATIONS. (COLOR SHALL BE AS INDICATED ON THE PLANS.) THE FOLLOWING ITEMS SHALL BE PAINTED WITH COLORS NOTED BELOW:  
PARKING STALLS: WHITE  
PEDESTRIAN CROSSWALKS: WHITE  
LANE STRIPING WHERE SEPARATING TRAFFIC IS MOVING IN OPPOSITE DIRECTIONS: YELLOW  
LANE STRIPING WHERE SEPARATING TRAFFIC IS MOVING IN SAME DIRECTIONS: WHITE  
ADA SYMBOLS: BLUE OR PER LOCAL CODE  
FIRE LANES: PER LOCAL CODE  
EXTERIOR SIDEWALK CURBED, LIGHT POLE BASES, AND GUARD POSTS: YELLOW

NOTE: PAVEMENT SHALL BE DESIGNED BY GEOTECHNICAL ENGINEER. MISSING INFORMATION ABOVE, DESIGNATED WITH (\*), SHALL BE FILLED IN PER GEOTECHNICAL REPORT. CAUTION: INFORMATION BELOW SHALL BE USED ONLY AS A GUIDE.

\* DENSE GRADED BASE GRADATIONS: 3-INCH, 1 1/4-INCH, OR 3/4-INCH (TYPICALLY 1 1/4-INCH)

\*\* HMA SUPERPAVE TYPES: E-0.3, E-1, E-3, E-10, E-30 (TYPICALLY E-0.3 OR E-1 FOR MOST RESIDENTIAL AND COMMERCIAL PROJECTS)

\*\*\* PG BINDERS:  
64-22 BASIC ASPHALT, TYPICALLY USED FOR PARKING LOTS  
58-28 RECOMMENDED FOR OVERLAY PROJECTS  
64-28 POLYMER ADDED, HIGH COST ASPHALT, LARGEST RANGE OF TEMP.  
UPPER LAYER PG64-28, PG64-22, OR PG58-28  
LOWER LAYER PG64-22 (IF UPPER LAYER IS PG64-xx OR HIGHER), OR PG58-28

\*\*\*\* HMA AGGREGATE GRADATIONS: 37.5 MM, 25.0 MM, 19.0 MM, 12.5 MM, 9.5 MM (TYPICALLY 12.5 MM FOR UPPER LAYER, 19.0 MM FOR LOWER LAYER)



V:\Projects\2018\118.1129.30\MEADOWLANDS\118.1129.30\AN.dwg, 5/22/2019 1:38:32 PM, bsnider, AutoCAD Plot (General Documentation) p35, ANSI (Differential) 1/4, 0.00 x 22.00 Inches, 1:1

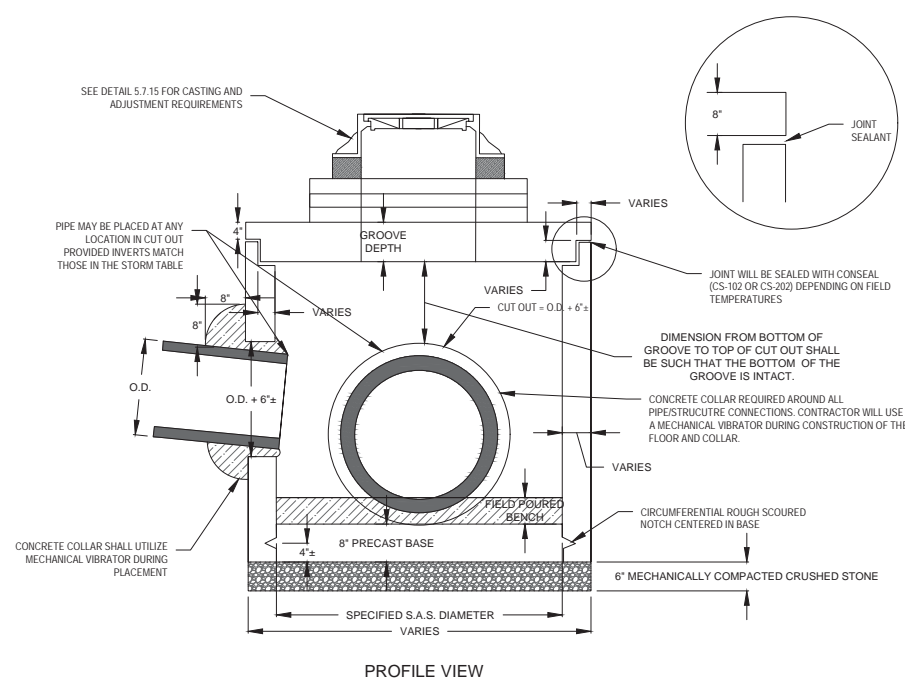

PROFILE VIEW

NOTE: ALL STORM SEWER ACCESS STRUCTURES (S.A.S.) SHALL BE CONSTRUCTED IN COMPLIANCE WITH ASTM C478.

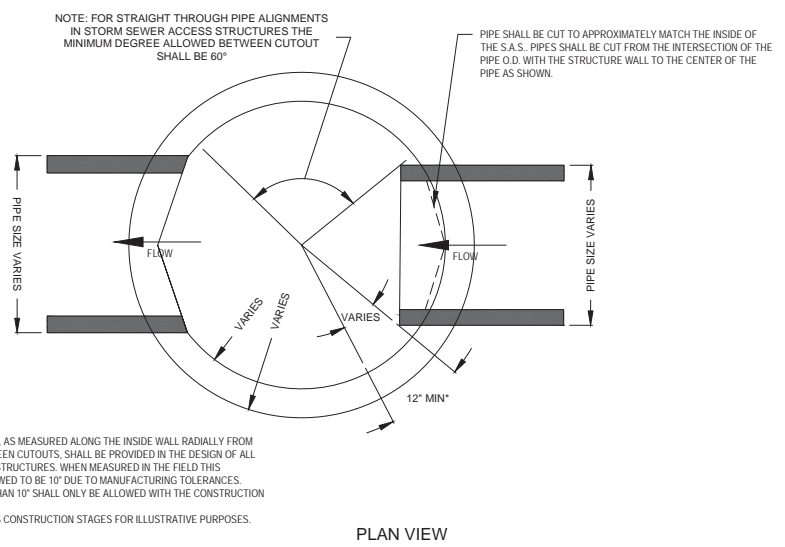

PLAN VIEW

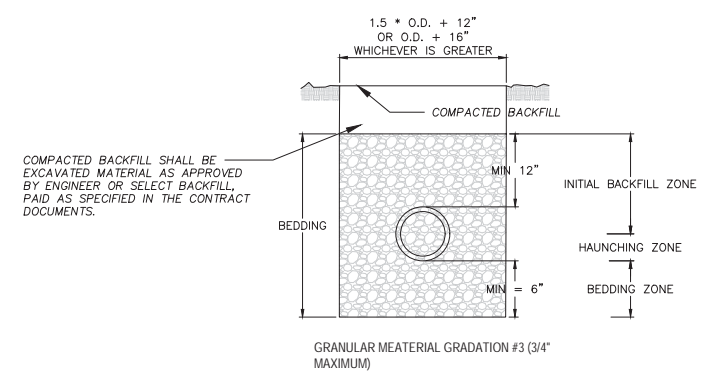

NOTES:  
 UNLESS OTHERWISE SPECIFIED, ALL SANITARY AND STORM SEWER PIPES, INCLUDING LATERALS AND LEADS, SHALL BE INSTALLED WITH THE TYPE OF BEDDING SHOWN FOR THE TYPE AND SIZE OF PIPE INSTALLED.  
 THE COST OF BEDDING SHALL BE INCLUDED IN THE UNIT PRICES BID FOR THE PIPE. FOR RCP, BEDDING INCLUDES THE HAUNCHING & BEDDING ZONES. FOR PLASTIC PIPES, THE BEDDING INCLUDES THE HAUNCHING, BEDDING & INITIAL BACKFILL ZONES. THE BEDDING SHALL BE INSTALLED & COMPACTED IN 6" MAXIMUM LIFTS.  
 ALL TRENCHES SHALL BE HAND BACKFILLED TO A POINT 12" ABOVE THE TOP OF THE PIPE. ALL BEDDING SHALL BE MECHANICALLY COMPACTED.  
 PAYMENT SHALL NOT BE MADE FOR BACKFILL WITH EXCAVATED MATERIAL, IF APPROVED. SELECT FILL IF REQUIRED. SHALL BE PAID PER CONTRACT.  
 THE MAXIMUM ALLOWABLE TRENCH WIDTH SHALL BE O.D. + 24" AND MINIMUM OF O.D. + 24" AS SPECIFIED, AND SHALL APPLY FROM THE BOTTOM OF THE TRENCH TO A POINT 12" ABOVE THE TOP OF THE PIPE. WHERE THIS WIDTH IS EXCEEDED, THE CONTRACTOR SHALL FURNISH AND INSTALL A HIGHER TYPE OF BEDDING AT NO EXTRA COST. THE TYPE OF BEDDING SHALL BE DETERMINED BY THE ENGINEER.  
 O.D. EQUALS THE OUTSIDE DIAMETER OF THE PIPE.

2 STORM PIPE BEDDING AND BACKFILL  
 C4.2 SCALE: NTS

1 PRECAST STORM SEWER  
 C4.2 SCALE: NTS

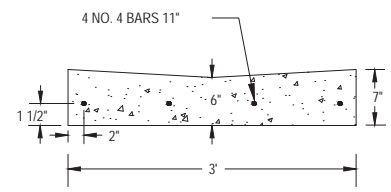

3 V-GUTTER DETAIL  
 C4.2 SCALE: NTS

MARK	REVISION	DATE	BY
Engineer: BCA	Checked By: MLC	Scale: 1" =	NOTED
Technician: BCA	Date: 01-07-2019	Field Bk:	Pg:
			C 4.2
			118.1129.30

MADISON, WI  
 5010 VOGES ROAD  
 MADISON, WISCONSIN 53718  
 608-838-0444 | www.snyder-associates.com

THE MEADOWLANDS - PHASE 11  
 UTILITY DETAILS  
**SNYDER & ASSOCIATES, INC.**



V:\Projects\2018\118.1129.30\MEADOWLANDS\PHASE 11\Utility Details\118.1129.30-0444.dwg, 5/22/2019 1:59:08 PM, barbara\_aud@cad.prf (General Documentation) pcs, ANS (Titleblock) D (4.00 x 22.00 inches), 11





**SiteASSIST™**  
by StormTech  
FOR STORMTECH  
INSTRUCTIONS,  
DOWNLOAD THE  
INSTALLATION APP



# The Meadowlands (A-1)

## Madison, WI

### STORMTECH CHAMBER SPECIFICATIONS

1. CHAMBERS SHALL BE STORMTECH SC-740, SC-310, OR APPROVED EQUAL.
2. CHAMBERS SHALL BE MANUFACTURED FROM VIRGIN POLYPROPYLENE OR POLYETHYLENE RESINS.
3. CHAMBER ROWS SHALL PROVIDE CONTINUOUS, UNOBSTRUCTED INTERNAL SPACE WITH NO INTERNAL SUPPORT PANELS THAT WOULD IMPEDE FLOW OR LIMIT ACCESS FOR INSPECTION.
4. THE STRUCTURAL DESIGN OF THE CHAMBERS, THE STRUCTURAL BACKFILL, AND THE INSTALLATION REQUIREMENTS SHALL ENSURE THAT THE LOAD FACTORS SPECIFIED IN THE AASHTO LRFD BRIDGE DESIGN SPECIFICATIONS, SECTION 12.12, ARE MET FOR: 1) LONG-DURATION DEAD LOADS AND 2) SHORT-DURATION LIVE LOADS, BASED ON THE AASHTO DESIGN TRUCK WITH CONSIDERATION FOR IMPACT AND MULTIPLE VEHICLE PRESENCES.
5. CHAMBERS SHALL MEET ASTM F2922 (POLYETHYLENE) OR ASTM F2418 (POLYPROPYLENE), "STANDARD SPECIFICATION FOR THERMOPLASTIC CORRUGATED WALL STORMWATER COLLECTION CHAMBERS".
6. CHAMBERS SHALL BE DESIGNED AND ALLOWABLE LOADS DETERMINED IN ACCORDANCE WITH ASTM F2787, "STANDARD PRACTICE FOR STRUCTURAL DESIGN OF THERMOPLASTIC CORRUGATED WALL STORMWATER COLLECTION CHAMBERS".
7. ONLY CHAMBERS THAT ARE APPROVED BY THE SITE DESIGN ENGINEER WILL BE ALLOWED. THE CHAMBER MANUFACTURER SHALL SUBMIT THE FOLLOWING UPON REQUEST TO THE SITE DESIGN ENGINEER FOR APPROVAL BEFORE DELIVERING CHAMBERS TO THE PROJECT SITE:
  - a. A STRUCTURAL EVALUATION SEALED BY A REGISTERED PROFESSIONAL ENGINEER THAT DEMONSTRATES THAT THE SAFETY FACTORS ARE GREATER THAN OR EQUAL TO 1.95 FOR DEAD LOAD AND 1.75 FOR LIVE LOAD, THE MINIMUM REQUIRED BY ASTM F2787 AND BY AASHTO FOR THERMOPLASTIC PIPE.
  - b. A STRUCTURAL EVALUATION SEALED BY A REGISTERED PROFESSIONAL ENGINEER THAT DEMONSTRATES THAT THE LOAD FACTORS SPECIFIED IN THE AASHTO LRFD BRIDGE DESIGN SPECIFICATIONS, SECTION 12.12, ARE MET. THE 50 YEAR CREEP MODULUS DATA SPECIFIED IN ASTM F2418 OR ASTM F2922 MUST BE USED AS PART OF THE AASHTO STRUCTURAL EVALUATION TO VERIFY LONG-TERM PERFORMANCE.
  - c. STRUCTURAL CROSS SECTION DETAIL ON WHICH THE STRUCTURAL EVALUATION IS BASED.
8. CHAMBERS AND END CAPS SHALL BE PRODUCED AT AN ISO 9001 CERTIFIED MANUFACTURING FACILITY.

### IMPORTANT - NOTES FOR THE BIDDING AND INSTALLATION OF THE SC-310/SC-740 SYSTEM

1. STORMTECH SC-310 & SC-740 CHAMBERS SHALL NOT BE INSTALLED UNTIL THE MANUFACTURER'S REPRESENTATIVE HAS COMPLETED A PRE-CONSTRUCTION MEETING WITH THE INSTALLERS.
2. STORMTECH SC-310 & SC-740 CHAMBERS SHALL BE INSTALLED IN ACCORDANCE WITH THE "STORMTECH SC-310/SC-740/SC-780 CONSTRUCTION GUIDE".
3. CHAMBERS ARE NOT TO BE BACKFILLED WITH A DOZER OR AN EXCAVATOR SITUATED OVER THE CHAMBERS.  
  
STORMTECH RECOMMENDS 3 BACKFILL METHODS:
  - STONESHOOTER LOCATED OFF THE CHAMBER BED.
  - BACKFILL AS ROWS ARE BUILT USING AN EXCAVATOR ON THE FOUNDATION STONE OR SUBGRADE.
  - BACKFILL FROM OUTSIDE THE EXCAVATION USING A LONG BOOM HOE OR EXCAVATOR.
4. THE FOUNDATION STONE SHALL BE LEVELED AND COMPACTED PRIOR TO PLACING CHAMBERS.
5. JOINTS BETWEEN CHAMBERS SHALL BE PROPERLY SEATED PRIOR TO PLACING STONE.
6. MAINTAIN MINIMUM - 6" (150 mm) SPACING BETWEEN THE CHAMBER ROWS.
7. EMBEDMENT STONE SURROUNDING CHAMBERS MUST BE A CLEAN, CRUSHED, ANGULAR STONE 3/4-2" (20-50 mm).
8. THE CONTRACTOR MUST REPORT ANY DISCREPANCIES WITH CHAMBER FOUNDATION MATERIALS BEARING CAPACITIES TO THE SITE DESIGN ENGINEER.
9. ADS RECOMMENDS THE USE OF "FLEXSTORM CATCH IT" INSERTS DURING CONSTRUCTION FOR ALL INLETS TO PROTECT THE SUBSURFACE STORMWATER MANAGEMENT SYSTEM FROM CONSTRUCTION SITE RUNOFF.

### NOTES FOR CONSTRUCTION EQUIPMENT

1. STORMTECH SC-310 & SC-740 CHAMBERS SHALL BE INSTALLED IN ACCORDANCE WITH THE "STORMTECH SC-310/SC-740/DC-780 CONSTRUCTION GUIDE".
2. THE USE OF CONSTRUCTION EQUIPMENT OVER SC-310 & SC-740 CHAMBERS IS LIMITED:
  - NO EQUIPMENT IS ALLOWED ON BARE CHAMBERS.
  - NO RUBBER Tired LOADERS, DUMP TRUCKS, OR EXCAVATORS ARE ALLOWED UNTIL PROPER FILL DEPTHS ARE REACHED IN ACCORDANCE WITH THE "STORMTECH SC-310/SC-740/DC-780 CONSTRUCTION GUIDE".
  - WEIGHT LIMITS FOR CONSTRUCTION EQUIPMENT CAN BE FOUND IN THE "STORMTECH SC-310/SC-740/DC-780 CONSTRUCTION GUIDE".
3. FULL 36" (900 mm) OF STABILIZED COVER MATERIALS OVER THE CHAMBERS IS REQUIRED FOR DUMP TRUCK TRAVEL OR DUMPING.

**USE OF A DOZER TO PUSH EMBEDMENT STONE BETWEEN THE ROWS OF CHAMBERS MAY CAUSE DAMAGE TO THE CHAMBERS AND IS NOT AN ACCEPTABLE BACKFILL METHOD. ANY CHAMBERS DAMAGED BY THE "DUMP AND PUSH" METHOD ARE NOT COVERED UNDER THE STORMTECH STANDARD WARRANTY.**

CONTACT STORMTECH AT 1-888-892-2694 WITH ANY QUESTIONS ON INSTALLATION REQUIREMENTS OR WEIGHT LIMITS FOR CONSTRUCTION EQUIPMENT.

**CONCEPTUAL LAYOUT**

(144) STORMTECH SC-740 CHAMBERS  
 (16) STORMTECH SC-740 END CAPS  
 INSTALLED WITH 6" COVER STONE, 30" BASE STONE, 40% STONE VOID  
**INSTALLED SYSTEM VOLUME: 15980 CF**  
 AREA OF SYSTEM: 5459 FT<sup>2</sup>  
 PERIMETER OF SYSTEM: 359 FT

**COMPUTER GENERATED CONCEPTUAL LAYOUT - NOT FOR CONSTRUCTION**

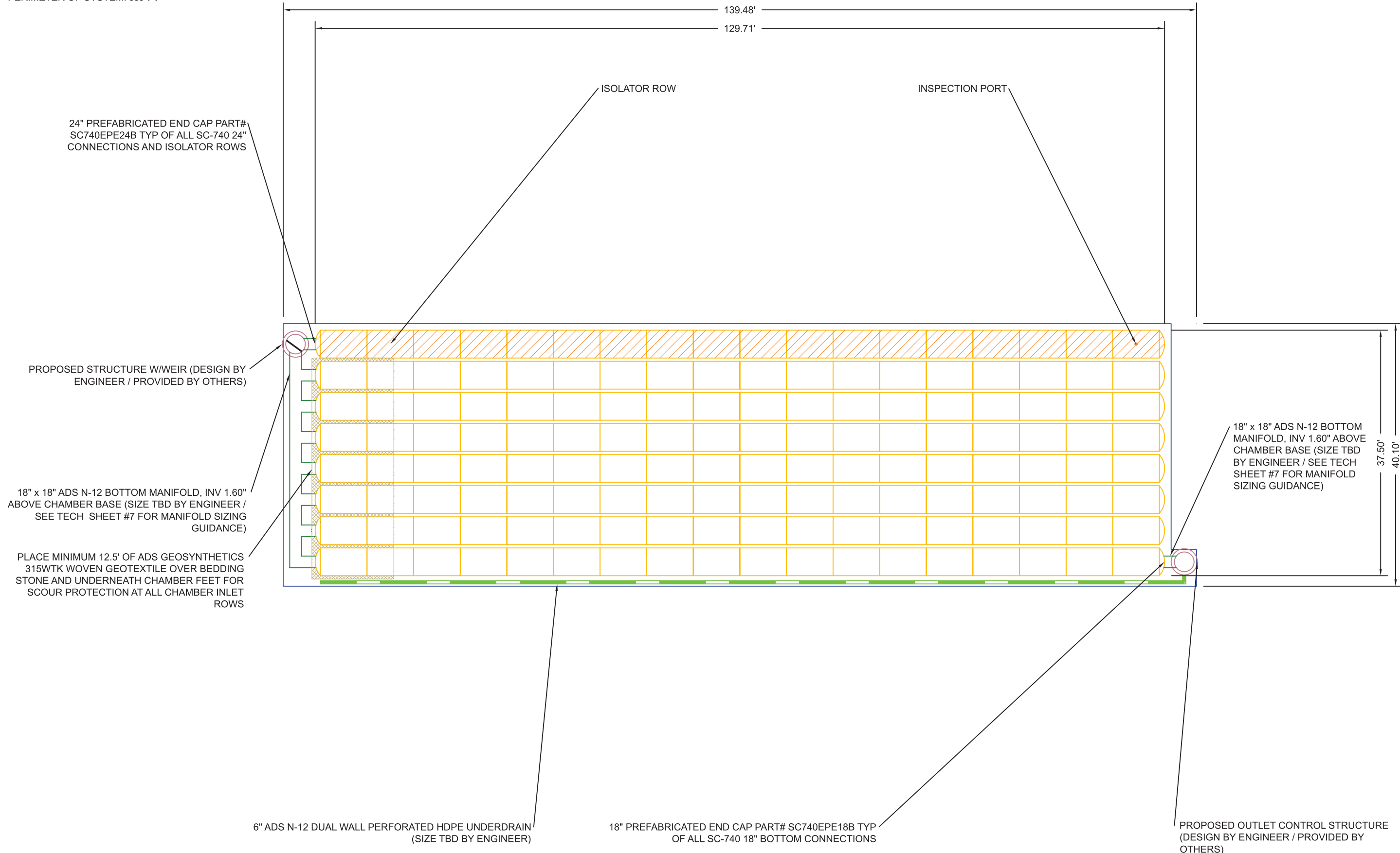

The Meadowlands (A-1) Madison, WI			
DATE: 01/29/2019	DRAWN: BA		
PROJECT #: Tool	CHECKED: ---		
REV	DRW	CHK	DESCRIPTION

**StormTech**  
 Delusion - Retention - Water Quality  
 70 NWWOOD ROAD, SUITE 3 | ROCKY HILL, CT | 06067  
 860-529-8188 | 866-892-2694 | WWW.STORMTECH.COM

4640 TRUEMAN BLVD  
 HILLIARD, OH 43026  
 1-800-733-7473

**ADS.**  
 ADVANCED DRAINAGE SYSTEMS, INC.

**NOT TO SCALE**

THIS DRAWING HAS BEEN PREPARED BASED ON INFORMATION PROVIDED TO ADS UNDER THE DIRECTION OF THE SITE DESIGN ENGINEER OR OTHER PROJECT REPRESENTATIVE. THE SITE DESIGN ENGINEER SHALL REVIEW THIS DRAWING PRIOR TO CONSTRUCTION. IT IS THE ULTIMATE RESPONSIBILITY OF THE SITE DESIGN ENGINEER TO ENSURE THAT THE PRODUCT(S) DEPICTED AND ALL ASSOCIATED DETAILS MEET ALL APPLICABLE LAWS, REGULATIONS, AND PROJECT REQUIREMENTS.

SHEET  
**2 OF 5**

## ACCEPTABLE FILL MATERIALS: STORMTECH SC-740 CHAMBER SYSTEMS

MATERIAL LOCATION	DESCRIPTION	AASHTO MATERIAL CLASSIFICATIONS	COMPACTION / DENSITY REQUIREMENT
D	<b>FINAL FILL:</b> FILL MATERIAL FOR LAYER 'D' STARTS FROM THE TOP OF THE 'C' LAYER TO THE BOTTOM OF FLEXIBLE PAVEMENT OR UNPAVED FINISHED GRADE ABOVE. NOTE THAT PAVEMENT SUBBASE MAY BE PART OF THE 'D' LAYER	N/A	PREPARE PER SITE DESIGN ENGINEER'S PLANS. PAVED INSTALLATIONS MAY HAVE STRINGENT MATERIAL AND PREPARATION REQUIREMENTS.
C	<b>INITIAL FILL:</b> FILL MATERIAL FOR LAYER 'C' STARTS FROM THE TOP OF THE EMBEDMENT STONE ('B' LAYER) TO 18" (450 mm) ABOVE THE TOP OF THE CHAMBER. NOTE THAT PAVEMENT SUBBASE MAY BE A PART OF THE 'C' LAYER.	AASHTO M145 <sup>1</sup> A-1, A-2-4, A-3  OR AASHTO M43 <sup>1</sup> 3, 357, 4, 467, 5, 56, 57, 6, 67, 68, 7, 78, 8, 89, 9, 10	BEGIN COMPACTIONS AFTER 12" (300 mm) OF MATERIAL OVER THE CHAMBERS IS REACHED. COMPACT ADDITIONAL LAYERS IN 6" (150 mm) MAX LIFTS TO A MIN. 95% PROCTOR DENSITY FOR WELL GRADED MATERIAL AND 95% RELATIVE DENSITY FOR PROCESSED AGGREGATE MATERIALS. ROLLER GROSS VEHICLE WEIGHT NOT TO EXCEED 12,000 lbs (53 kN). DYNAMIC FORCE NOT TO EXCEED 20,000 lbs (89 kN).
B	<b>EMBEDMENT STONE:</b> FILL SURROUNDING THE CHAMBERS FROM THE FOUNDATION STONE ('A' LAYER) TO THE 'C' LAYER ABOVE.	AASHTO M43 <sup>1</sup> 3, 357, 4, 467, 5, 56, 57	NO COMPACTION REQUIRED.
A	<b>FOUNDATION STONE:</b> FILL BELOW CHAMBERS FROM THE SUBGRADE UP TO THE FOOT (BOTTOM) OF THE CHAMBER.	AASHTO M43 <sup>1</sup> 3, 357, 4, 467, 5, 56, 57	PLATE COMPACT OR ROLL TO ACHIEVE A FLAT SURFACE. <sup>2 3</sup>

**PLEASE NOTE:**

- THE LISTED AASHTO DESIGNATIONS ARE FOR GRADATIONS ONLY. THE STONE MUST ALSO BE CLEAN, CRUSHED, ANGULAR. FOR EXAMPLE, A SPECIFICATION FOR #4 STONE WOULD STATE: "CLEAN, CRUSHED, ANGULAR NO. 4 (AASHTO M43) STONE".
- STORMTECH COMPACTION REQUIREMENTS ARE MET FOR 'A' LOCATION MATERIALS WHEN PLACED AND COMPACTED IN 6" (150 mm) (MAX) LIFTS USING TWO FULL COVERAGES WITH A VIBRATORY COMPACTOR.
- WHERE INFILTRATION SURFACES MAY BE COMPROMISED BY COMPACTION, FOR STANDARD DESIGN LOAD CONDITIONS, A FLAT SURFACE MAY BE ACHIEVED BY RAKING OR DRAGGING WITHOUT COMPACTION EQUIPMENT. FOR SPECIAL LOAD DESIGNS, CONTACT STORMTECH FOR COMPACTION REQUIREMENTS.

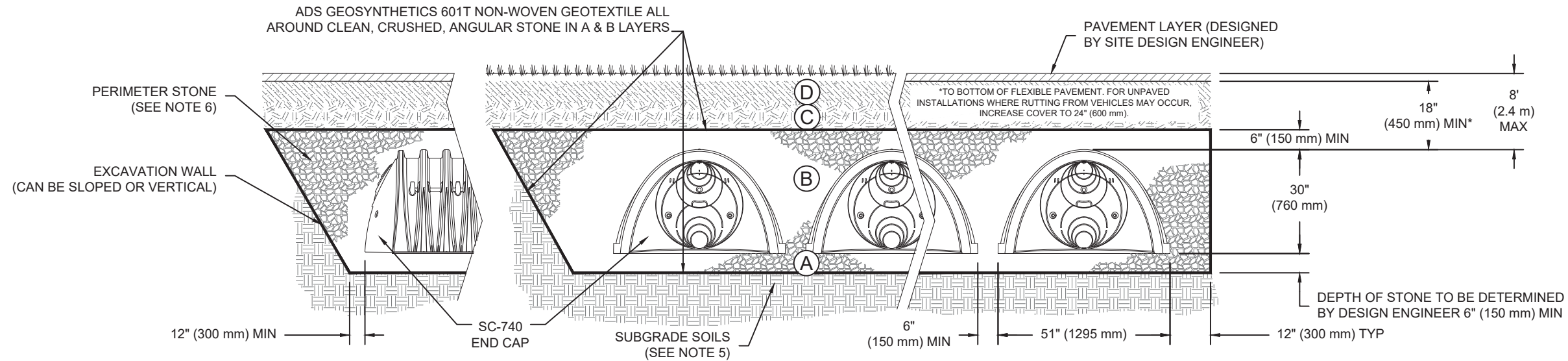

**NOTES:**

- SC-740 CHAMBERS SHALL CONFORM TO THE REQUIREMENTS OF ASTM F2418 "STANDARD SPECIFICATION FOR POLYPROPYLENE (PP) CORRUGATED WALL STORMWATER COLLECTION CHAMBERS", OR ASTM F2922 "STANDARD SPECIFICATION FOR POLYETHYLENE (PE) CORRUGATED WALL STORMWATER COLLECTION CHAMBERS".
- SC-740 CHAMBERS SHALL BE DESIGNED IN ACCORDANCE WITH ASTM F2787 "STANDARD PRACTICE FOR STRUCTURAL DESIGN OF THERMOPLASTIC CORRUGATED WALL STORMWATER COLLECTION CHAMBERS".
- "ACCEPTABLE FILL MATERIALS" TABLE ABOVE PROVIDES MATERIAL LOCATIONS, DESCRIPTIONS, GRADATIONS, AND COMPACTION REQUIREMENTS FOR FOUNDATION, EMBEDMENT, AND FILL MATERIALS.
- THE "SITE DESIGN ENGINEER" REFERS TO THE ENGINEER RESPONSIBLE FOR THE DESIGN AND LAYOUT OF THE STORMTECH CHAMBERS FOR THIS PROJECT.
- THE SITE DESIGN ENGINEER IS RESPONSIBLE FOR ASSESSING THE BEARING RESISTANCE (ALLOWABLE BEARING CAPACITY) OF THE SUBGRADE SOILS AND THE DEPTH OF FOUNDATION STONE WITH CONSIDERATION FOR THE RANGE OF EXPECTED SOIL MOISTURE CONDITIONS.
- PERIMETER STONE MUST BE EXTENDED HORIZONTALLY TO THE EXCAVATION WALL FOR BOTH VERTICAL AND SLOPED EXCAVATION WALLS.
- ONCE LAYER 'C' IS PLACED, ANY SOIL/MATERIAL CAN BE PLACED IN LAYER 'D' UP TO THE FINISHED GRADE. MOST PAVEMENT SUBBASE SOILS CAN BE USED TO REPLACE THE MATERIAL REQUIREMENTS OF LAYER 'C' OR 'D' AT THE SITE DESIGN ENGINEER'S DISCRETION.

<b>The Meadowlands (A-1)</b> Madison, WI	DATE: 01/29/2019 DRAWN: BA PROJECT #: Tool CHECKED: ---	<p>70 INWOOD ROAD, SUITE 3   ROCKY HILL   CT   06867                  860-525-8188   888-892-2694   WWW.STORMTECH.COM</p>
DESCRIPTION	CHK	
REV	DRW	
4640 TRUEMAN BLVD HILLIARD, OH 43026 1-800-733-7473		
<p>ADVANCED DRAINAGE SYSTEMS, INC.</p>		
SHEET <b>3 OF 5</b>		

THIS DRAWING HAS BEEN PREPARED BASED ON INFORMATION PROVIDED TO ADS UNDER THE DIRECTION OF THE SITE DESIGN ENGINEER OR OTHER PROJECT REPRESENTATIVE. THE SITE DESIGN ENGINEER SHALL REVIEW THIS DRAWING PRIOR TO CONSTRUCTION. IT IS THE ULTIMATE RESPONSIBILITY OF THE SITE DESIGN ENGINEER TO ENSURE THAT THE PRODUCT(S) DEPICTED AND ALL ASSOCIATED DETAILS MEET ALL APPLICABLE LAWS, REGULATIONS, AND PROJECT REQUIREMENTS.

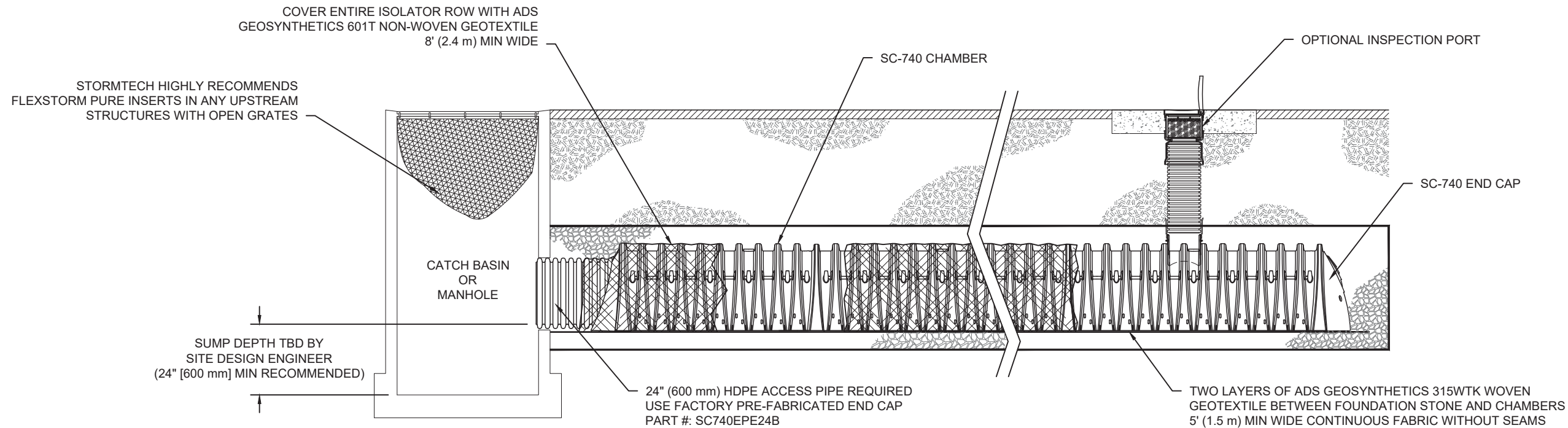

**SC-740 ISOLATOR ROW DETAIL**  
NTS

**INSPECTION & MAINTENANCE**

- STEP 1) INSPECT ISOLATOR ROW FOR SEDIMENT
- A. INSPECTION PORTS (IF PRESENT)
    - A.1. REMOVE/OPEN LID ON NYLOPLAST INLINE DRAIN
    - A.2. REMOVE AND CLEAN FLEXSTORM FILTER IF INSTALLED
    - A.3. USING A FLASHLIGHT AND STADIA ROD, MEASURE DEPTH OF SEDIMENT AND RECORD ON MAINTENANCE LOG
    - A.4. LOWER A CAMERA INTO ISOLATOR ROW FOR VISUAL INSPECTION OF SEDIMENT LEVELS (OPTIONAL)
    - A.5. IF SEDIMENT IS AT, OR ABOVE, 3" (80 mm) PROCEED TO STEP 2. IF NOT, PROCEED TO STEP 3.
  - B. ALL ISOLATOR ROWS
    - B.1. REMOVE COVER FROM STRUCTURE AT UPSTREAM END OF ISOLATOR ROW
    - B.2. USING A FLASHLIGHT, INSPECT DOWN THE ISOLATOR ROW THROUGH OUTLET PIPE
      - i) MIRRORS ON POLES OR CAMERAS MAY BE USED TO AVOID A CONFINED SPACE ENTRY
      - ii) FOLLOW OSHA REGULATIONS FOR CONFINED SPACE ENTRY IF ENTERING MANHOLE
    - B.3. IF SEDIMENT IS AT, OR ABOVE, 3" (80 mm) PROCEED TO STEP 2. IF NOT, PROCEED TO STEP 3.
- STEP 2) CLEAN OUT ISOLATOR ROW USING THE JETVAC PROCESS
- A. A FIXED CULVERT CLEANING NOZZLE WITH REAR FACING SPREAD OF 45° (1.1 m) OR MORE IS PREFERRED
  - B. APPLY MULTIPLE PASSES OF JETVAC UNTIL BACKFLUSH WATER IS CLEAN
  - C. VACUUM STRUCTURE SUMP AS REQUIRED
- STEP 3) REPLACE ALL COVERS, GRATES, FILTERS, AND LIDS; RECORD OBSERVATIONS AND ACTIONS.
- STEP 4) INSPECT AND CLEAN BASINS AND MANHOLES UPSTREAM OF THE STORMTECH SYSTEM.

**NOTES**

1. INSPECT EVERY 6 MONTHS DURING THE FIRST YEAR OF OPERATION. ADJUST THE INSPECTION INTERVAL BASED ON PREVIOUS OBSERVATIONS OF SEDIMENT ACCUMULATION AND HIGH WATER ELEVATIONS.
2. CONDUCT JETTING AND VACTORING ANNUALLY OR WHEN INSPECTION SHOWS THAT MAINTENANCE IS NECESSARY.

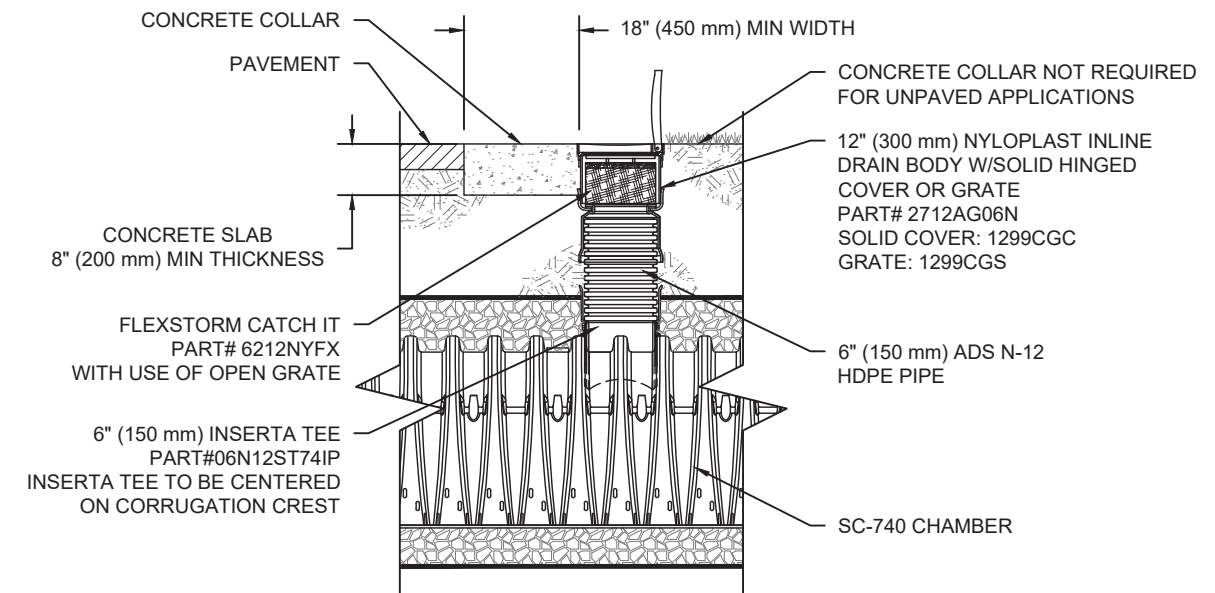

**SC-740 6" INSPECTION PORT DETAIL**  
NTS

The Meadowlands (A-1) Madison, WI	
DATE: 01/29/2019	DRAWN: BA
PROJECT #: Tool	CHECKED: ---

REV	DRW	CHK	DESCRIPTION

  
 70 INWOOD ROAD, SUITE 3 | ROCKY HILL, CT | 06067  
 860-525-8188 | 888-892-2694 | WWW.STORMTECH.COM

  
 4640 TRUEMAN BLVD  
 HILLIARD, OH 43026  
 1-800-733-7473  
 ADVANCED DRAINAGE SYSTEMS, INC.

THIS DRAWING HAS BEEN PREPARED BASED ON INFORMATION PROVIDED TO ADS UNDER THE DIRECTION OF THE SITE DESIGN ENGINEER OR OTHER PROJECT REPRESENTATIVE. THE SITE DESIGN ENGINEER SHALL REVIEW THIS DRAWING PRIOR TO CONSTRUCTION. IT IS THE ULTIMATE RESPONSIBILITY OF THE SITE DESIGN ENGINEER TO ENSURE THAT THE PRODUCT(S) DEPICTED AND ALL ASSOCIATED DETAILS MEET ALL APPLICABLE LAWS, REGULATIONS, AND PROJECT REQUIREMENTS.

**UNDERDRAIN DETAIL**

NTS

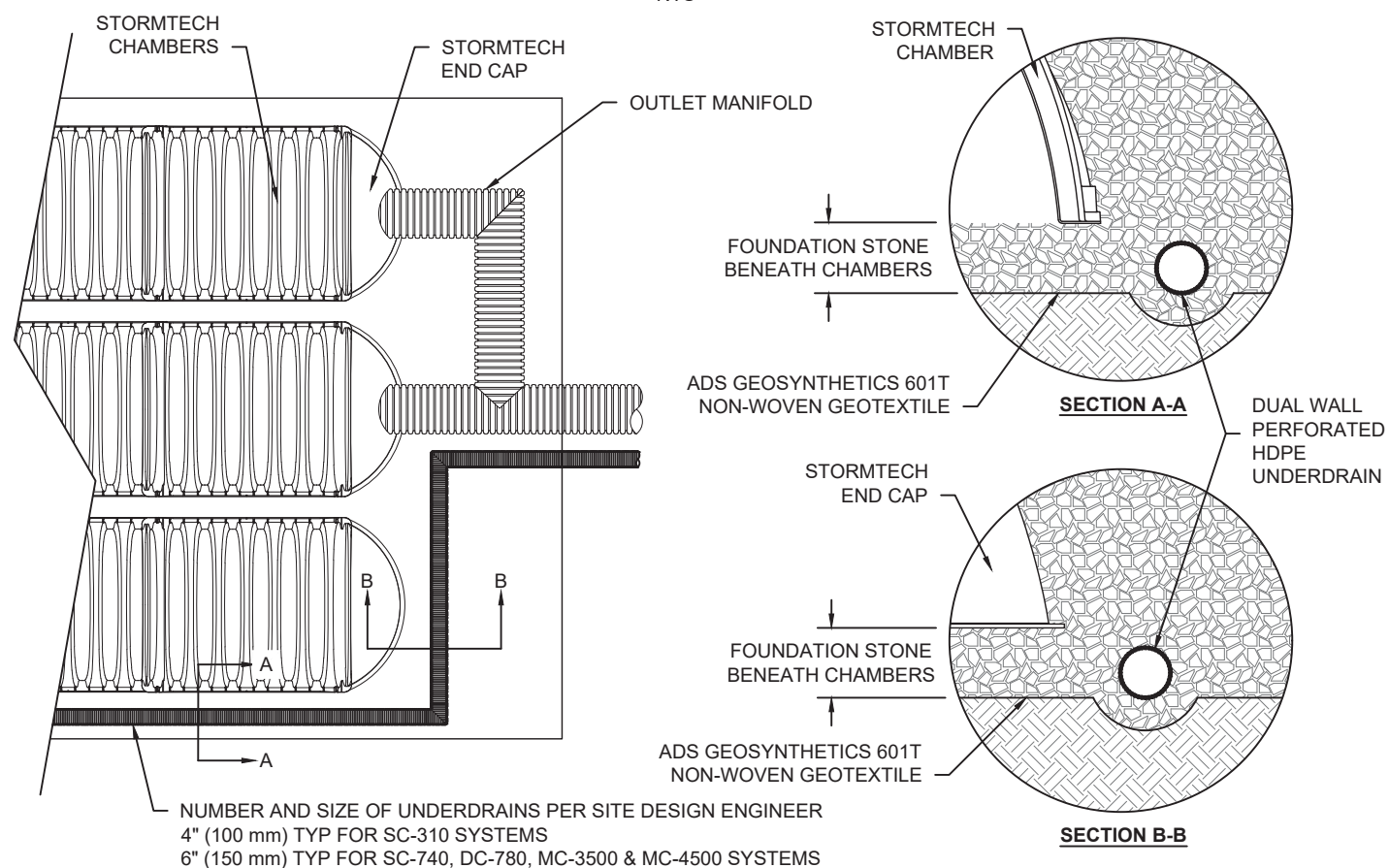

**INSERTA TEE DETAIL**

NTS

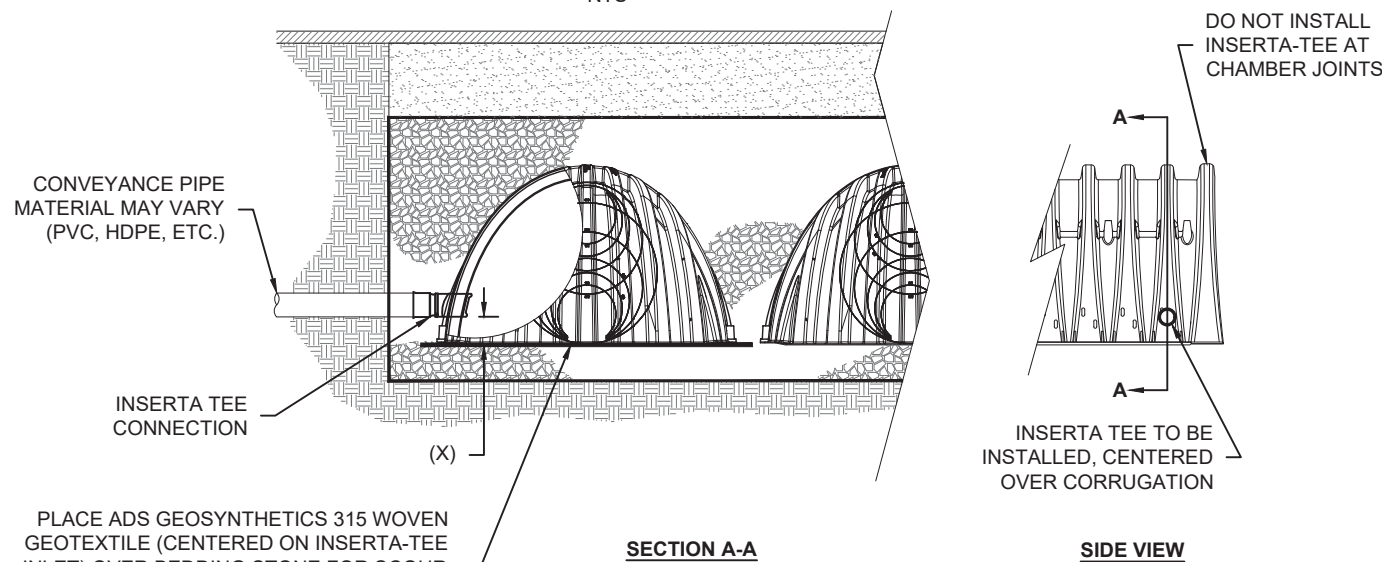

CHAMBER	MAX DIAMETER OF INSERTA TEE	HEIGHT FROM BASE OF CHAMBER (X)
SC-310	6" (150 mm)	4" (100 mm)
SC-740	10" (250 mm)	4" (100 mm)
DC-780	10" (250 mm)	4" (100 mm)
MC-3500	12" (300 mm)	6" (150 mm)
MC-4500	12" (300 mm)	8" (200 mm)

**NOTE:**  
PART NUMBERS WILL VARY BASED ON INLET PIPE MATERIALS. CONTACT STORMTECH FOR MORE INFORMATION.

INSERTA TEE FITTINGS AVAILABLE FOR SDR 26, SDR 35, SCH 40 IPS GASKETED & SOLVENT WELD, N-12, HP STORM, C-900 OR DUCTILE IRON

**SC-740 TECHNICAL SPECIFICATION**

NTS

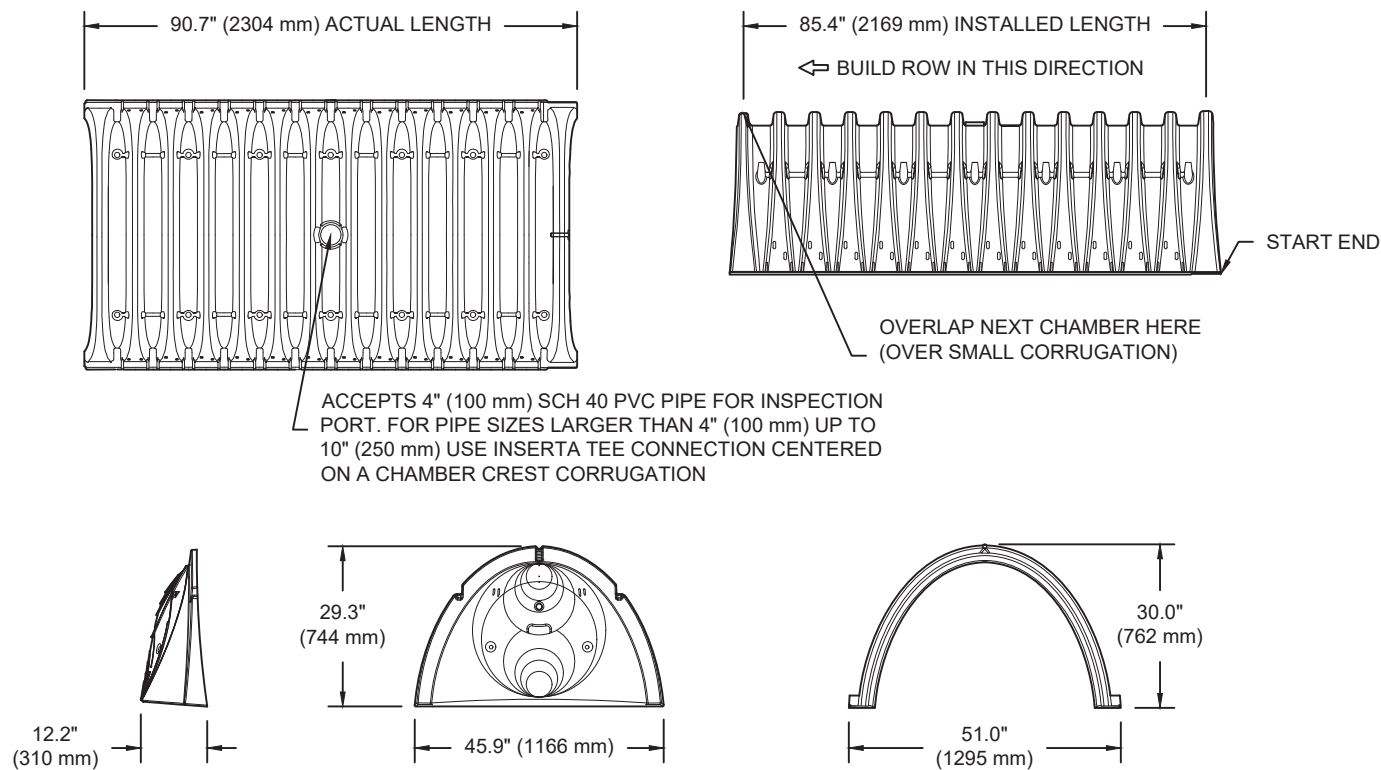

**NOMINAL CHAMBER SPECIFICATIONS**

SIZE (W X H X INSTALLED LENGTH)	51.0" X 30.0" X 85.4"	(1295 mm X 762 mm X 2169 mm)
CHAMBER STORAGE	45.9 CUBIC FEET	(1.30 m <sup>3</sup> )
MINIMUM INSTALLED STORAGE*	74.9 CUBIC FEET	(2.12 m <sup>3</sup> )
WEIGHT	75.0 lbs.	(33.6 kg)

\*ASSUMES 6" (152 mm) STONE ABOVE, BELOW, AND BETWEEN CHAMBERS

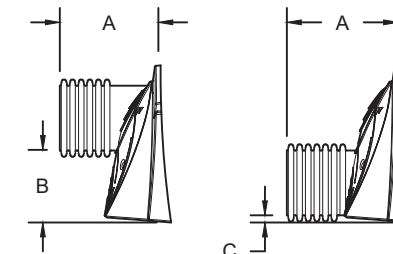

STUBS AT BOTTOM OF END CAP FOR PART NUMBERS ENDING WITH "B"

STUBS AT TOP OF END CAP FOR PART NUMBERS ENDING WITH "T"

PART #	STUB	A	B	C
SC740EPE06T / SC740EPE06TPC	6" (150 mm)	10.9" (277 mm)	18.5" (470 mm)	---
SC740EPE06B / SC740EPE06BPC	---	---	---	0.5" (13 mm)
SC740EPE08T / SC740EPE08TPC	8" (200 mm)	12.2" (310 mm)	16.5" (419 mm)	---
SC740EPE08B / SC740EPE08BPC	---	---	---	0.6" (15 mm)
SC740EPE10T / SC740EPE10TPC	10" (250 mm)	13.4" (340 mm)	14.5" (368 mm)	---
SC740EPE10B / SC740EPE10BPC	---	---	---	0.7" (18 mm)
SC740EPE12T / SC740EPE12TPC	12" (300 mm)	14.7" (373 mm)	12.5" (318 mm)	---
SC740EPE12B / SC740EPE12BPC	---	---	---	1.2" (30 mm)
SC740EPE15T / SC740EPE15TPC	15" (375 mm)	18.4" (467 mm)	9.0" (229 mm)	---
SC740EPE15B / SC740EPE15BPC	---	---	---	1.3" (33 mm)
SC740EPE18T / SC740EPE18TPC	18" (450 mm)	19.7" (500 mm)	5.0" (127 mm)	---
SC740EPE18B / SC740EPE18BPC	---	---	---	1.6" (41 mm)
SC740EPE24B*	24" (600 mm)	18.5" (470 mm)	---	0.1" (3 mm)

ALL STUBS, EXCEPT FOR THE SC740EPE24B ARE PLACED AT BOTTOM OF END CAP SUCH THAT THE OUTSIDE DIAMETER OF THE STUB IS FLUSH WITH THE BOTTOM OF THE END CAP. FOR ADDITIONAL INFORMATION CONTACT STORMTECH AT 1-888-892-2694.

\* FOR THE SC740EPE24B THE 24" (600 mm) STUB LIES BELOW THE BOTTOM OF THE END CAP APPROXIMATELY 1.75" (44 mm). BACKFILL MATERIAL SHOULD BE REMOVED FROM BELOW THE N-12 STUB SO THAT THE FITTING SITS LEVEL.

NOTE: ALL DIMENSIONS ARE NOMINAL

The Meadowlands (A-1)  
Madison, WI

DESCRIPTION

CHK

REV

**StormTech**  
Dedicated. Rejuvenation. Water Quality.  
70 INWOOD ROAD, SUITE 3 | ROCKY HILL | CT | 06067  
860-525-8188 | 888-892-2694 | WWW.STORMTECH.COM

4640 TRUJMAN BLVD  
HILLIARD, OH 43026  
1-800-733-7473  
**ADS**  
ADVANCED DRAINAGE SYSTEMS, INC.

DATE: 01/29/2019  
DRAWN: BA  
PROJECT #: Tool  
CHECKED: ---

THIS DRAWING HAS BEEN PREPARED BASED ON INFORMATION PROVIDED TO ADS UNDER THE DIRECTION OF THE SITE DESIGN ENGINEER OR OTHER PROJECT REPRESENTATIVE. THE SITE DESIGN ENGINEER SHALL REVIEW THIS DRAWING PRIOR TO CONSTRUCTION. IT IS THE ULTIMATE RESPONSIBILITY OF THE SITE DESIGN ENGINEER TO ENSURE THAT THE PRODUCT(S) DEPICTED AND ALL ASSOCIATED DETAILS MEET ALL APPLICABLE LAWS, REGULATIONS, AND PROJECT REQUIREMENTS.



ADVANCED DRAINAGE SYSTEMS, INC.

**SiteASSIST™**  
by StormTech  
FOR STORMTECH  
INSTRUCTIONS,  
DOWNLOAD THE  
INSTALLATION APP



# The Meadowlands (A-2)

Madison, WI

## STORMTECH CHAMBER SPECIFICATIONS

1. CHAMBERS SHALL BE STORMTECH SC-740, SC-310, OR APPROVED EQUAL.
2. CHAMBERS SHALL BE MANUFACTURED FROM VIRGIN POLYPROPYLENE OR POLYETHYLENE RESINS.
3. CHAMBER ROWS SHALL PROVIDE CONTINUOUS, UNOBSTRUCTED INTERNAL SPACE WITH NO INTERNAL SUPPORT PANELS THAT WOULD IMPEDE FLOW OR LIMIT ACCESS FOR INSPECTION.
4. THE STRUCTURAL DESIGN OF THE CHAMBERS, THE STRUCTURAL BACKFILL, AND THE INSTALLATION REQUIREMENTS SHALL ENSURE THAT THE LOAD FACTORS SPECIFIED IN THE AASHTO LRFD BRIDGE DESIGN SPECIFICATIONS, SECTION 12.12, ARE MET FOR: 1) LONG-DURATION DEAD LOADS AND 2) SHORT-DURATION LIVE LOADS, BASED ON THE AASHTO DESIGN TRUCK WITH CONSIDERATION FOR IMPACT AND MULTIPLE VEHICLE PRESENCES.
5. CHAMBERS SHALL MEET ASTM F2922 (POLYETHYLENE) OR ASTM F2418 (POLYPROPYLENE), "STANDARD SPECIFICATION FOR THERMOPLASTIC CORRUGATED WALL STORMWATER COLLECTION CHAMBERS".
6. CHAMBERS SHALL BE DESIGNED AND ALLOWABLE LOADS DETERMINED IN ACCORDANCE WITH ASTM F2787, "STANDARD PRACTICE FOR STRUCTURAL DESIGN OF THERMOPLASTIC CORRUGATED WALL STORMWATER COLLECTION CHAMBERS".
7. ONLY CHAMBERS THAT ARE APPROVED BY THE SITE DESIGN ENGINEER WILL BE ALLOWED. THE CHAMBER MANUFACTURER SHALL SUBMIT THE FOLLOWING UPON REQUEST TO THE SITE DESIGN ENGINEER FOR APPROVAL BEFORE DELIVERING CHAMBERS TO THE PROJECT SITE:
  - a. A STRUCTURAL EVALUATION SEALED BY A REGISTERED PROFESSIONAL ENGINEER THAT DEMONSTRATES THAT THE SAFETY FACTORS ARE GREATER THAN OR EQUAL TO 1.95 FOR DEAD LOAD AND 1.75 FOR LIVE LOAD, THE MINIMUM REQUIRED BY ASTM F2787 AND BY AASHTO FOR THERMOPLASTIC PIPE.
  - b. A STRUCTURAL EVALUATION SEALED BY A REGISTERED PROFESSIONAL ENGINEER THAT DEMONSTRATES THAT THE LOAD FACTORS SPECIFIED IN THE AASHTO LRFD BRIDGE DESIGN SPECIFICATIONS, SECTION 12.12, ARE MET. THE 50 YEAR CREEP MODULUS DATA SPECIFIED IN ASTM F2418 OR ASTM F2922 MUST BE USED AS PART OF THE AASHTO STRUCTURAL EVALUATION TO VERIFY LONG-TERM PERFORMANCE.
  - c. STRUCTURAL CROSS SECTION DETAIL ON WHICH THE STRUCTURAL EVALUATION IS BASED.
8. CHAMBERS AND END CAPS SHALL BE PRODUCED AT AN ISO 9001 CERTIFIED MANUFACTURING FACILITY.

## IMPORTANT - NOTES FOR THE BIDDING AND INSTALLATION OF THE SC-310/SC-740 SYSTEM

1. STORMTECH SC-310 & SC-740 CHAMBERS SHALL NOT BE INSTALLED UNTIL THE MANUFACTURER'S REPRESENTATIVE HAS COMPLETED A PRE-CONSTRUCTION MEETING WITH THE INSTALLERS.
2. STORMTECH SC-310 & SC-740 CHAMBERS SHALL BE INSTALLED IN ACCORDANCE WITH THE "STORMTECH SC-310/SC-740/SC-780 CONSTRUCTION GUIDE".
3. CHAMBERS ARE NOT TO BE BACKFILLED WITH A DOZER OR AN EXCAVATOR SITUATED OVER THE CHAMBERS.  
  
STORMTECH RECOMMENDS 3 BACKFILL METHODS:
  - STONESHOOTER LOCATED OFF THE CHAMBER BED.
  - BACKFILL AS ROWS ARE BUILT USING AN EXCAVATOR ON THE FOUNDATION STONE OR SUBGRADE.
  - BACKFILL FROM OUTSIDE THE EXCAVATION USING A LONG BOOM HOE OR EXCAVATOR.
4. THE FOUNDATION STONE SHALL BE LEVELED AND COMPACTED PRIOR TO PLACING CHAMBERS.
5. JOINTS BETWEEN CHAMBERS SHALL BE PROPERLY SEATED PRIOR TO PLACING STONE.
6. MAINTAIN MINIMUM - 6" (150 mm) SPACING BETWEEN THE CHAMBER ROWS.
7. EMBEDMENT STONE SURROUNDING CHAMBERS MUST BE A CLEAN, CRUSHED, ANGULAR STONE 3/4-2" (20-50 mm).
8. THE CONTRACTOR MUST REPORT ANY DISCREPANCIES WITH CHAMBER FOUNDATION MATERIALS BEARING CAPACITIES TO THE SITE DESIGN ENGINEER.
9. ADS RECOMMENDS THE USE OF "FLEXSTORM CATCH IT" INSERTS DURING CONSTRUCTION FOR ALL INLETS TO PROTECT THE SUBSURFACE STORMWATER MANAGEMENT SYSTEM FROM CONSTRUCTION SITE RUNOFF.

## NOTES FOR CONSTRUCTION EQUIPMENT

1. STORMTECH SC-310 & SC-740 CHAMBERS SHALL BE INSTALLED IN ACCORDANCE WITH THE "STORMTECH SC-310/SC-740/DC-780 CONSTRUCTION GUIDE".
2. THE USE OF CONSTRUCTION EQUIPMENT OVER SC-310 & SC-740 CHAMBERS IS LIMITED:
  - NO EQUIPMENT IS ALLOWED ON BARE CHAMBERS.
  - NO RUBBER Tired LOADERS, DUMP TRUCKS, OR EXCAVATORS ARE ALLOWED UNTIL PROPER FILL DEPTHS ARE REACHED IN ACCORDANCE WITH THE "STORMTECH SC-310/SC-740/DC-780 CONSTRUCTION GUIDE".
  - WEIGHT LIMITS FOR CONSTRUCTION EQUIPMENT CAN BE FOUND IN THE "STORMTECH SC-310/SC-740/DC-780 CONSTRUCTION GUIDE".
3. FULL 36" (900 mm) OF STABILIZED COVER MATERIALS OVER THE CHAMBERS IS REQUIRED FOR DUMP TRUCK TRAVEL OR DUMPING.

**USE OF A DOZER TO PUSH EMBEDMENT STONE BETWEEN THE ROWS OF CHAMBERS MAY CAUSE DAMAGE TO THE CHAMBERS AND IS NOT AN ACCEPTABLE BACKFILL METHOD. ANY CHAMBERS DAMAGED BY THE "DUMP AND PUSH" METHOD ARE NOT COVERED UNDER THE STORMTECH STANDARD WARRANTY.**

CONTACT STORMTECH AT 1-888-892-2694 WITH ANY QUESTIONS ON INSTALLATION REQUIREMENTS OR WEIGHT LIMITS FOR CONSTRUCTION EQUIPMENT.

**CONCEPTUAL LAYOUT**

(110) STORMTECH SC-310 CHAMBERS  
 (22) STORMTECH SC-310 END CAPS  
 INSTALLED WITH 6" COVER STONE, 30" BASE STONE, 40% STONE VOID  
**INSTALLED SYSTEM VOLUME: 6242 CF**  
 AREA OF SYSTEM: 3039 FT<sup>2</sup>  
 PERIMETER OF SYSTEM: 241 FT

**COMPUTER GENERATED CONCEPTUAL LAYOUT - NOT FOR CONSTRUCTION**

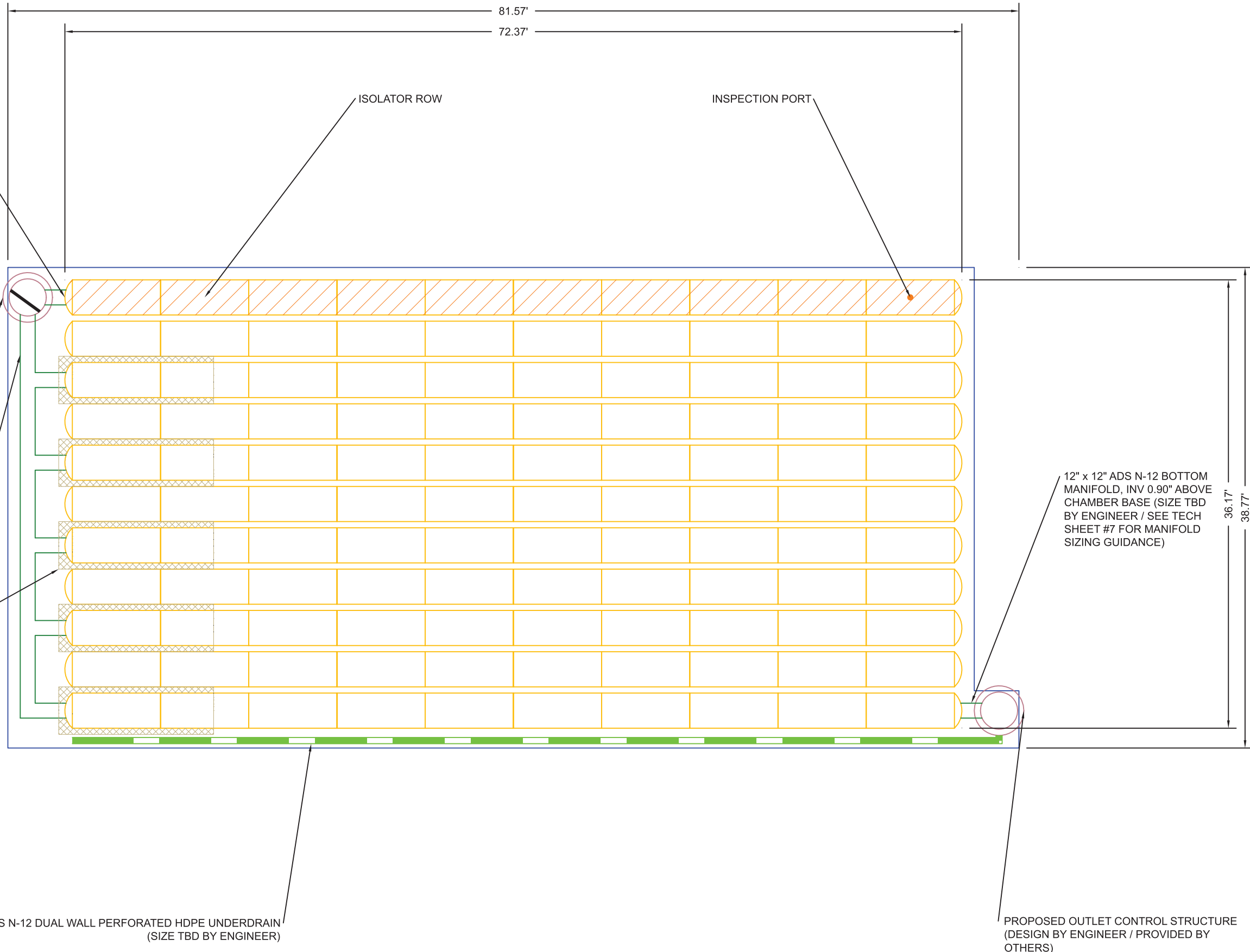

12" PREFABRICATED END CAP PART# SC310EPE12B TYP OF ALL SC-310 12" CONNECTIONS AND ISOLATOR ROWS

PROPOSED STRUCTURE W/WEIR (DESIGN BY ENGINEER / PROVIDED BY OTHERS)

12" x 12" ADS N-12 BOTTOM MANIFOLD, INV NO INVERT IS AVAILABLE ABOVE CHAMBER BASE (SIZE TBD BY ENGINEER / SEE TECH SHEET #7 FOR MANIFOLD SIZING GUIDANCE)

PLACE MINIMUM 12.5' OF ADS GEOSYNTHETICS 315WTK WOVEN GEOTEXTILE OVER BEDDING STONE AND UNDERNEATH CHAMBER FEET FOR SCOUR PROTECTION AT ALL CHAMBER INLET ROWS

6" ADS N-12 DUAL WALL PERFORATED HDPE UNDERDRAIN (SIZE TBD BY ENGINEER)

PROPOSED OUTLET CONTROL STRUCTURE (DESIGN BY ENGINEER / PROVIDED BY OTHERS)

The Meadowlands (A-2) Madison, WI		DATE: 01/29/2019	DRAWN: BA
REV		PROJECT #: Tool	CHECKED: ---
DESCRIPTION	CHK	DRW	REV
<p>StormTech                  Detention - Retention - Water Quality                  70 NWWOOD ROAD, SUITE 3   ROCKY HILL, CT   06067                  860-529-8188   866-892-2694   WWW.STORMTECH.COM</p>			
<p>ADS                  ADVANCED DRAINAGE SYSTEMS, INC.                  4640 TRUEMAN BLVD                  HILLIARD, OH 43026                  1-800-733-7473</p>		<p>NOT TO SCALE</p>	
<p>SHEET                  2 OF 5</p>			

THIS DRAWING HAS BEEN PREPARED BASED ON INFORMATION PROVIDED TO ADS UNDER THE DIRECTION OF THE SITE DESIGN ENGINEER OR OTHER PROJECT REPRESENTATIVE. THE SITE DESIGN ENGINEER SHALL REVIEW THIS DRAWING PRIOR TO CONSTRUCTION. IT IS THE ULTIMATE RESPONSIBILITY OF THE SITE DESIGN ENGINEER TO ENSURE THAT THE PRODUCT(S) DEPICTED AND ALL ASSOCIATED DETAILS MEET ALL APPLICABLE LAWS, REGULATIONS, AND PROJECT REQUIREMENTS.

## ACCEPTABLE FILL MATERIALS: STORMTECH SC-310 CHAMBER SYSTEMS

MATERIAL LOCATION	DESCRIPTION	AASHTO MATERIAL CLASSIFICATIONS	COMPACTION / DENSITY REQUIREMENT
D	<b>FINAL FILL:</b> FILL MATERIAL FOR LAYER 'D' STARTS FROM THE TOP OF THE 'C' LAYER TO THE BOTTOM OF FLEXIBLE PAVEMENT OR UNPAVED FINISHED GRADE ABOVE. NOTE THAT PAVEMENT SUBBASE MAY BE PART OF THE 'D' LAYER	N/A	PREPARE PER SITE DESIGN ENGINEER'S PLANS. PAVED INSTALLATIONS MAY HAVE STRINGENT MATERIAL AND PREPARATION REQUIREMENTS.
C	<b>INITIAL FILL:</b> FILL MATERIAL FOR LAYER 'C' STARTS FROM THE TOP OF THE EMBEDMENT STONE ('B' LAYER) TO 18" (450 mm) ABOVE THE TOP OF THE CHAMBER. NOTE THAT PAVEMENT SUBBASE MAY BE A PART OF THE 'C' LAYER.	AASHTO M145 <sup>1</sup> A-1, A-2-4, A-3  OR AASHTO M43 <sup>1</sup> 3, 357, 4, 467, 5, 56, 57, 6, 67, 68, 7, 78, 8, 89, 9, 10	BEGIN COMPACTIONS AFTER 12" (300 mm) OF MATERIAL OVER THE CHAMBERS IS REACHED. COMPACT ADDITIONAL LAYERS IN 6" (150 mm) MAX LIFTS TO A MIN. 95% PROCTOR DENSITY FOR WELL GRADED MATERIAL AND 95% RELATIVE DENSITY FOR PROCESSED AGGREGATE MATERIALS. ROLLER GROSS VEHICLE WEIGHT NOT TO EXCEED 12,000 lbs (53 kN). DYNAMIC FORCE NOT TO EXCEED 20,000 lbs (89 kN).
B	<b>EMBEDMENT STONE:</b> FILL SURROUNDING THE CHAMBERS FROM THE FOUNDATION STONE ('A' LAYER) TO THE 'C' LAYER ABOVE.	AASHTO M43 <sup>1</sup> 3, 357, 4, 467, 5, 56, 57	NO COMPACTION REQUIRED.
A	<b>FOUNDATION STONE:</b> FILL BELOW CHAMBERS FROM THE SUBGRADE UP TO THE FOOT (BOTTOM) OF THE CHAMBER.	AASHTO M43 <sup>1</sup> 3, 357, 4, 467, 5, 56, 57	PLATE COMPACT OR ROLL TO ACHIEVE A FLAT SURFACE. <sup>2 3</sup>

**PLEASE NOTE:**

- THE LISTED AASHTO DESIGNATIONS ARE FOR GRADATIONS ONLY. THE STONE MUST ALSO BE CLEAN, CRUSHED, ANGULAR. FOR EXAMPLE, A SPECIFICATION FOR #4 STONE WOULD STATE: "CLEAN, CRUSHED, ANGULAR NO. 4 (AASHTO M43) STONE".
- STORMTECH COMPACTION REQUIREMENTS ARE MET FOR 'A' LOCATION MATERIALS WHEN PLACED AND COMPACTED IN 6" (150 mm) (MAX) LIFTS USING TWO FULL COVERAGES WITH A VIBRATORY COMPACTOR.
- WHERE INFILTRATION SURFACES MAY BE COMPROMISED BY COMPACTION, FOR STANDARD DESIGN LOAD CONDITIONS, A FLAT SURFACE MAY BE ACHIEVED BY RAKING OR DRAGGING WITHOUT COMPACTION EQUIPMENT. FOR SPECIAL LOAD DESIGNS, CONTACT STORMTECH FOR COMPACTION REQUIREMENTS.

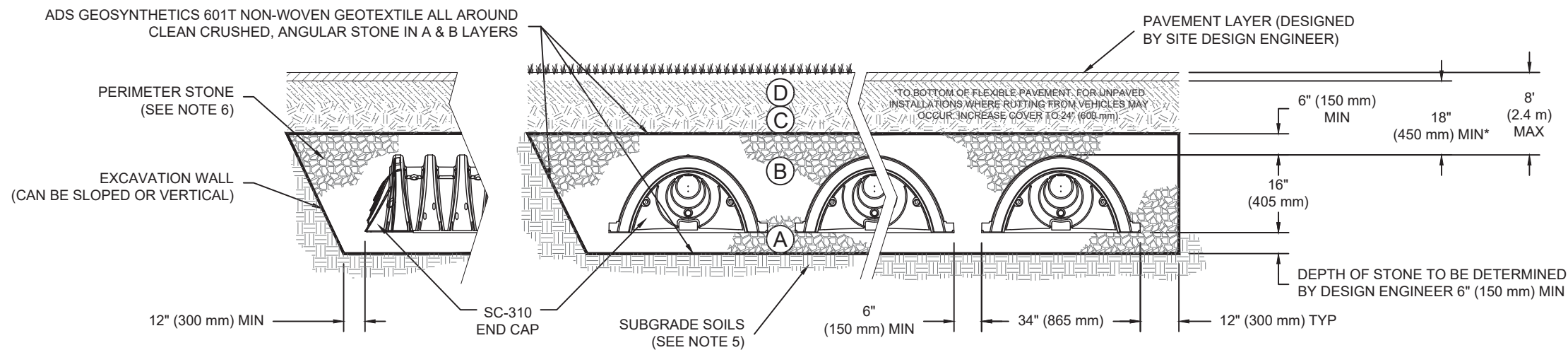

**NOTES:**

- SC-310 CHAMBERS SHALL CONFORM TO THE REQUIREMENTS OF ASTM F2418 "STANDARD SPECIFICATION FOR POLYPROPYLENE (PP) CORRUGATED WALL STORMWATER COLLECTION CHAMBERS", OR ASTM F2922 "STANDARD SPECIFICATION FOR POLYETHYLENE (PE) CORRUGATED WALL STORMWATER COLLECTION CHAMBERS".
- SC-310 CHAMBERS SHALL BE DESIGNED IN ACCORDANCE WITH ASTM F2787 "STANDARD PRACTICE FOR STRUCTURAL DESIGN OF THERMOPLASTIC CORRUGATED WALL STORMWATER COLLECTION CHAMBERS".
- "ACCEPTABLE FILL MATERIALS" TABLE ABOVE PROVIDES MATERIAL LOCATIONS, DESCRIPTIONS, GRADATIONS, AND COMPACTION REQUIREMENTS FOR FOUNDATION, EMBEDMENT, AND FILL MATERIALS.
- THE "SITE DESIGN ENGINEER" REFERS TO THE ENGINEER RESPONSIBLE FOR THE DESIGN AND LAYOUT OF THE STORMTECH CHAMBERS FOR THIS PROJECT.
- THE SITE DESIGN ENGINEER IS RESPONSIBLE FOR ASSESSING THE BEARING RESISTANCE (ALLOWABLE BEARING CAPACITY) OF THE SUBGRADE SOILS AND THE DEPTH OF FOUNDATION STONE WITH CONSIDERATION FOR THE RANGE OF EXPECTED SOIL MOISTURE CONDITIONS.
- PERIMETER STONE MUST BE EXTENDED HORIZONTALLY TO THE EXCAVATION WALL FOR BOTH VERTICAL AND SLOPED EXCAVATION WALLS.
- ONCE LAYER 'C' IS PLACED, ANY SOIL/MATERIAL CAN BE PLACED IN LAYER 'D' UP TO THE FINISHED GRADE. MOST PAVEMENT SUBBASE SOILS CAN BE USED TO REPLACE THE MATERIAL REQUIREMENTS OF LAYER 'C' OR 'D' AT THE SITE DESIGN ENGINEER'S DISCRETION.

<b>The Meadowlands (A-2)</b> Madison, WI	DATE: 01/29/2019 DRAWN: BA PROJECT #: Tool CHECKED: ---	<p style="font-size: small;">70 INWOOD ROAD, SUITE 3   ROCKY HILL   CT   06867                  860-525-8188   888-892-2694   WWW.STORMTECH.COM</p>
DESCRIPTION		
CHK		
DRW		
REV		
		4640 TRUEMAN BLVD HILLIARD, OH 43026 1-800-733-7473 <p style="font-size: x-small;">ADVANCED DRAINAGE SYSTEMS, INC.</p>
THIS DRAWING HAS BEEN PREPARED BASED ON INFORMATION PROVIDED TO ADS UNDER THE DIRECTION OF THE SITE DESIGN ENGINEER OR OTHER PROJECT REPRESENTATIVE. THE SITE DESIGN ENGINEER SHALL REVIEW THIS DRAWING PRIOR TO CONSTRUCTION. IT IS THE ULTIMATE RESPONSIBILITY OF THE SITE DESIGN ENGINEER TO ENSURE THAT THE PRODUCT(S) DEPICTED AND ALL ASSOCIATED DETAILS MEET ALL APPLICABLE LAWS, REGULATIONS, AND PROJECT REQUIREMENTS.		
SHEET <b>3 OF 5</b>		



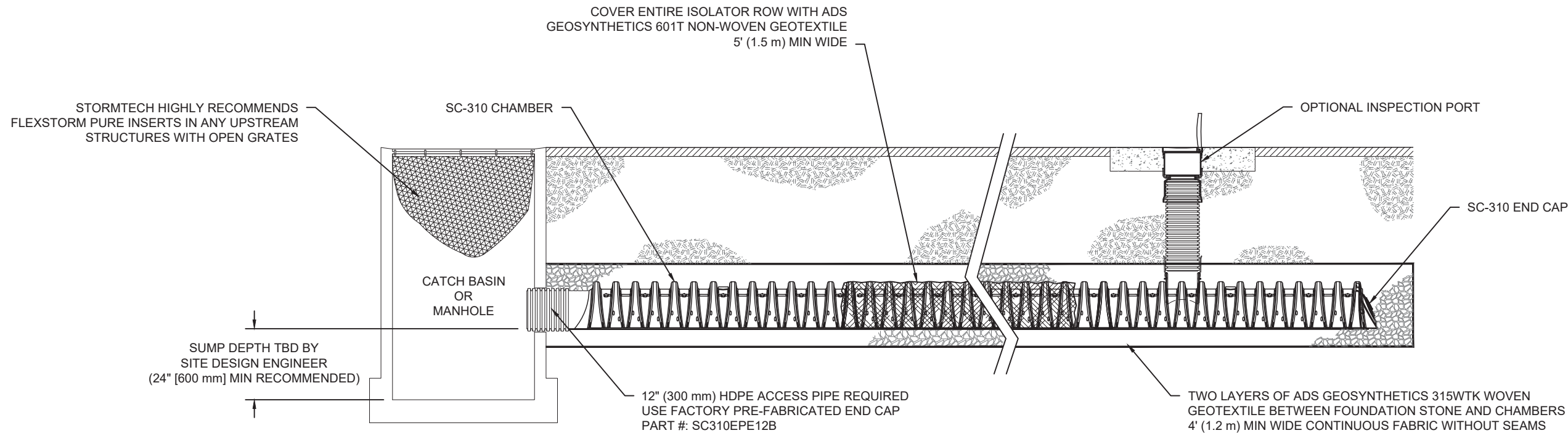

**SC-310 ISOLATOR ROW DETAIL**  
NTS

**INSPECTION & MAINTENANCE**

- STEP 1) INSPECT ISOLATOR ROW FOR SEDIMENT
- A. INSPECTION PORTS (IF PRESENT)
    - A.1. REMOVE/OPEN LID ON NYLOPLAST INLINE DRAIN
    - A.2. REMOVE AND CLEAN FLEXSTORM FILTER IF INSTALLED
    - A.3. USING A FLASHLIGHT AND STADIA ROD, MEASURE DEPTH OF SEDIMENT AND RECORD ON MAINTENANCE LOG
    - A.4. LOWER A CAMERA INTO ISOLATOR ROW FOR VISUAL INSPECTION OF SEDIMENT LEVELS (OPTIONAL)
    - A.5. IF SEDIMENT IS AT, OR ABOVE, 3" (80 mm) PROCEED TO STEP 2. IF NOT, PROCEED TO STEP 3.
  - B. ALL ISOLATOR ROWS
    - B.1. REMOVE COVER FROM STRUCTURE AT UPSTREAM END OF ISOLATOR ROW
    - B.2. USING A FLASHLIGHT, INSPECT DOWN THE ISOLATOR ROW THROUGH OUTLET PIPE
      - i) MIRRORS ON POLES OR CAMERAS MAY BE USED TO AVOID A CONFINED SPACE ENTRY
      - ii) FOLLOW OSHA REGULATIONS FOR CONFINED SPACE ENTRY IF ENTERING MANHOLE
    - B.3. IF SEDIMENT IS AT, OR ABOVE, 3" (80 mm) PROCEED TO STEP 2. IF NOT, PROCEED TO STEP 3.
- STEP 2) CLEAN OUT ISOLATOR ROW USING THE JETVAC PROCESS
- A. A FIXED CULVERT CLEANING NOZZLE WITH REAR FACING SPREAD OF 45" (1.1 m) OR MORE IS PREFERRED
  - B. APPLY MULTIPLE PASSES OF JETVAC UNTIL BACKFLUSH WATER IS CLEAN
  - C. VACUUM STRUCTURE SUMP AS REQUIRED
- STEP 3) REPLACE ALL COVERS, GRATES, FILTERS, AND LIDS; RECORD OBSERVATIONS AND ACTIONS.
- STEP 4) INSPECT AND CLEAN BASINS AND MANHOLES UPSTREAM OF THE STORMTECH SYSTEM.

**NOTES**

1. INSPECT EVERY 6 MONTHS DURING THE FIRST YEAR OF OPERATION. ADJUST THE INSPECTION INTERVAL BASED ON PREVIOUS OBSERVATIONS OF SEDIMENT ACCUMULATION AND HIGH WATER ELEVATIONS.
2. CONDUCT JETTING AND VACTORING ANNUALLY OR WHEN INSPECTION SHOWS THAT MAINTENANCE IS NECESSARY.

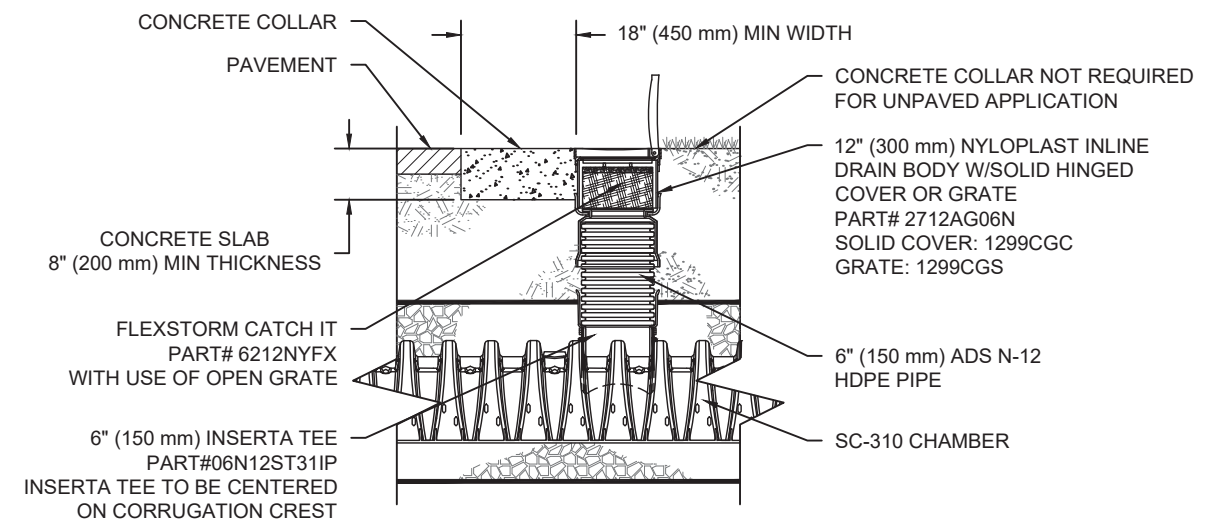

**SC-310 6" INSPECTION PORT DETAIL**  
NTS

The Meadowlands (A-2)	
Madison, WI	
DATE: 01/29/2019	DRAWN: BA
PROJECT #: Tool	CHECKED: ---

REV	DRW	CHK	DESCRIPTION

  
**StormTech**  
Defining Resilient Water Quality  
 70 INWOOD ROAD, SUITE 3 | ROCKY HILL, CT | 06067  
 860-525-8188 | 888-892-2694 | WWW.STORMTECH.COM

4640 TRUJEMAN BLVD  
 HILLIARD, OH 43026  
 1-800-733-7473  
  
ADVANCED DRAINAGE SYSTEMS, INC.

THIS DRAWING HAS BEEN PREPARED BASED ON INFORMATION PROVIDED TO ADS UNDER THE DIRECTION OF THE SITE DESIGN ENGINEER OR OTHER PROJECT REPRESENTATIVE. THE SITE DESIGN ENGINEER SHALL REVIEW THIS DRAWING PRIOR TO CONSTRUCTION. IT IS THE ULTIMATE RESPONSIBILITY OF THE SITE DESIGN ENGINEER TO ENSURE THAT THE PRODUCT(S) DEPICTED AND ALL ASSOCIATED DETAILS MEET ALL APPLICABLE LAWS, REGULATIONS, AND PROJECT REQUIREMENTS.

**UNDERDRAIN DETAIL**

NTS

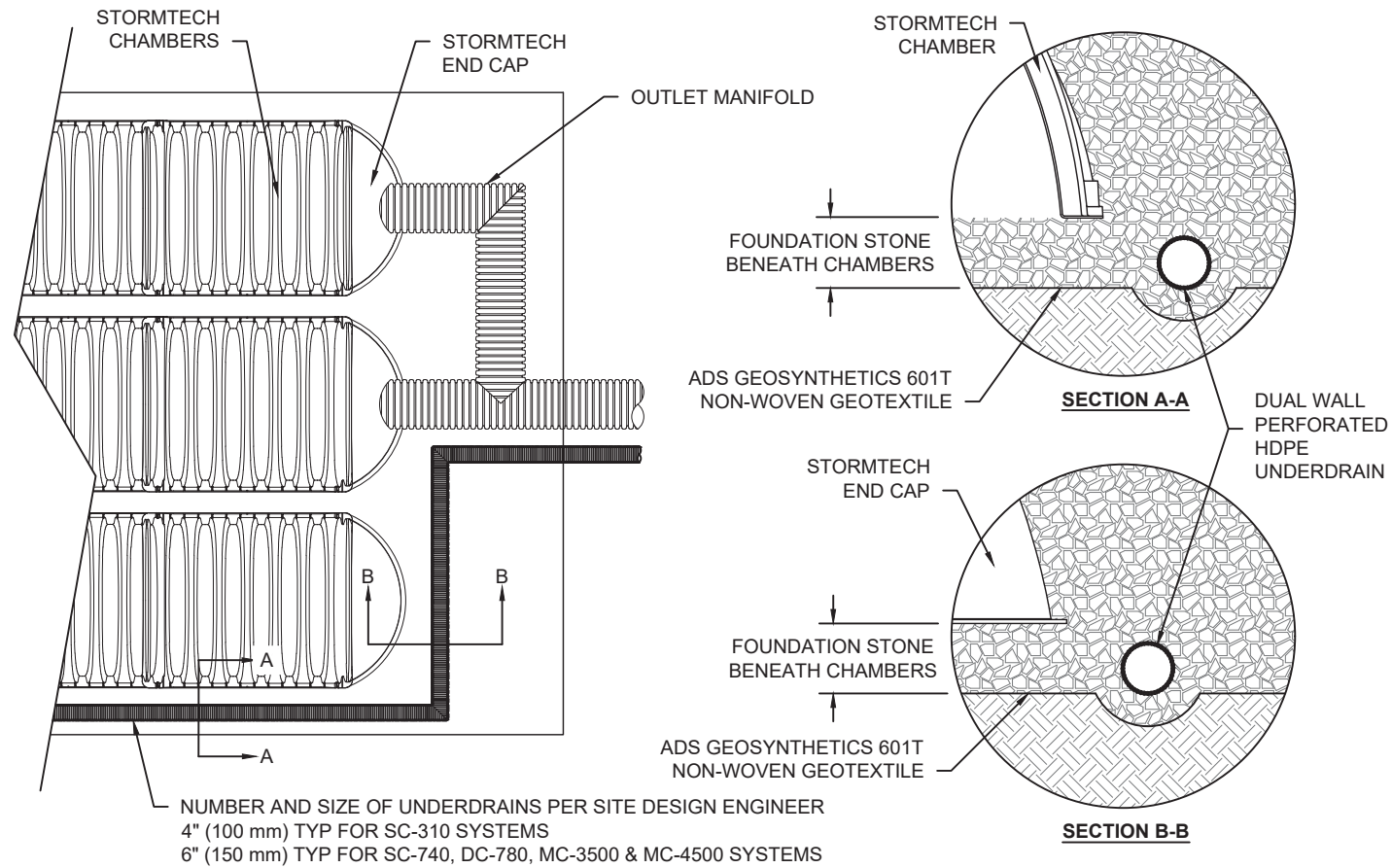

**INSERTA TEE DETAIL**

NTS

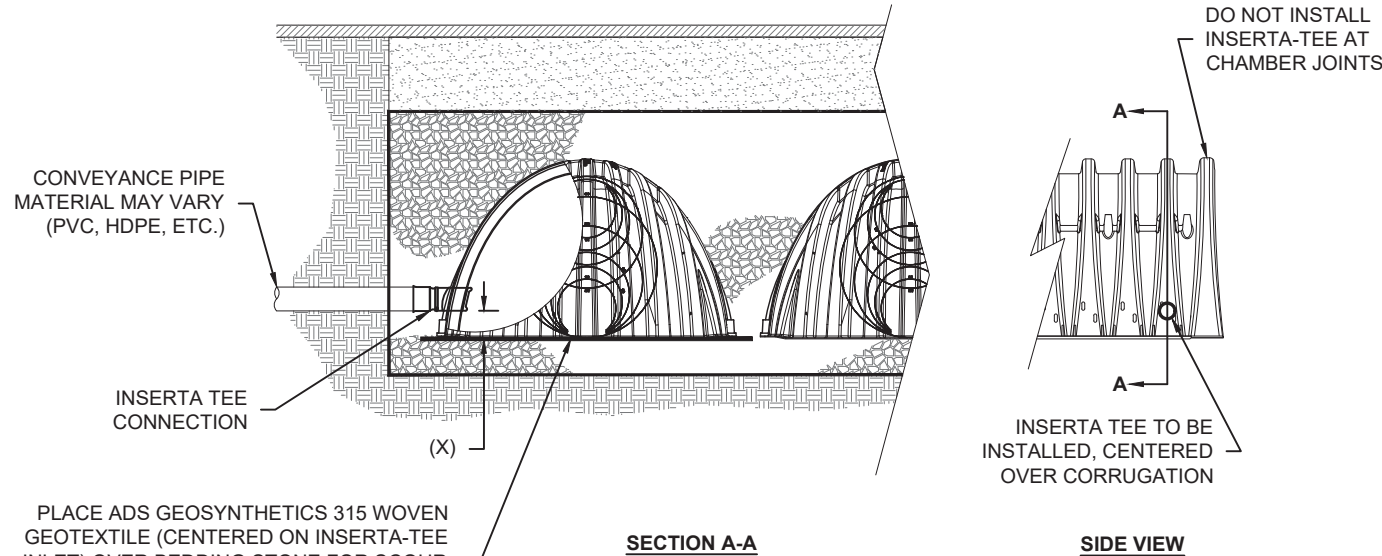

CHAMBER	MAX DIAMETER OF INSERTA TEE	HEIGHT FROM BASE OF CHAMBER (X)
SC-310	6" (150 mm)	4" (100 mm)
SC-740	10" (250 mm)	4" (100 mm)
DC-780	10" (250 mm)	4" (100 mm)
MC-3500	12" (300 mm)	6" (150 mm)
MC-4500	12" (300 mm)	8" (200 mm)

INSERTA TEE FITTINGS AVAILABLE FOR SDR 26, SDR 35, SCH 40 IPS GASKETED & SOLVENT WELD, N-12, HP STORM, C-900 OR DUCTILE IRON

**NOTE:**  
PART NUMBERS WILL VARY BASED ON INLET PIPE MATERIALS. CONTACT STORMTECH FOR MORE INFORMATION.

**SC-310 TECHNICAL SPECIFICATION**

NTS

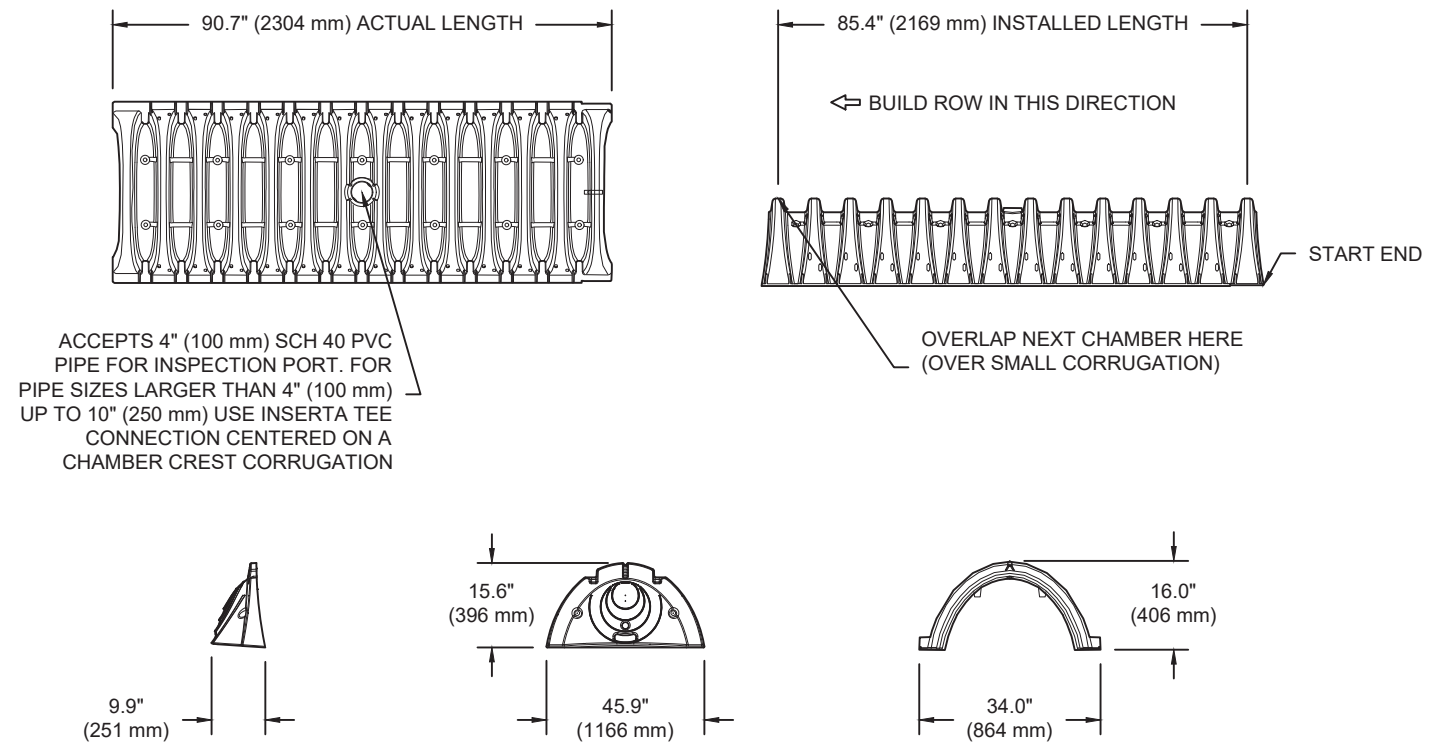

**NOMINAL CHAMBER SPECIFICATIONS**

SIZE (W X H X INSTALLED LENGTH)	CHAMBER STORAGE	MINIMUM INSTALLED STORAGE*	WEIGHT
34.0" X 16.0" X 85.4"	14.7 CUBIC FEET	31.0 CUBIC FEET	35.0 lbs.
(864 mm X 406 mm X 2169 mm)	(0.42 m <sup>3</sup> )	(0.88 m <sup>3</sup> )	(16.8 kg)

\*ASSUMES 6" (152 mm) ABOVE, BELOW, AND BETWEEN CHAMBERS

STUBS AT BOTTOM OF END CAP FOR PART NUMBERS ENDING WITH "B"  
STUBS AT TOP OF END CAP FOR PART NUMBERS ENDING WITH "T"

PART #	STUB	A	B	C
SC310EPE06T / SC310EPE06TPC	6" (150 mm)	9.6" (244 mm)	5.8" (147 mm)	---
SC310EPE06B / SC310EPE06BPC			---	0.5" (13 mm)
SC310EPE08T / SC310EPE08TPC	8" (200 mm)	11.9" (302 mm)	3.5" (89 mm)	---
SC310EPE08B / SC310EPE08BPC			---	0.6" (15 mm)
SC310EPE10T / SC310EPE10TPC	10" (250 mm)	12.7" (323 mm)	1.4" (36 mm)	---
SC310EPE10B / SC310EPE10BPC			---	0.7" (18 mm)
SC310EPE12B	12" (300 mm)	13.5" (343 mm)	---	0.9" (23 mm)

ALL STUBS, EXCEPT FOR THE SC310EPE12B ARE PLACED AT BOTTOM OF END CAP SUCH THAT THE OUTSIDE DIAMETER OF THE STUB IS FLUSH WITH THE BOTTOM OF THE END CAP. FOR ADDITIONAL INFORMATION CONTACT STORMTECH AT 1-888-892-2694.

\* FOR THE SC310EPE12B THE 12" (300 mm) STUB LIES BELOW THE BOTTOM OF THE END CAP APPROXIMATELY 0.25" (6 mm). BACKFILL MATERIAL SHOULD BE REMOVED FROM BELOW THE N-12 STUB SO THAT THE FITTING SITS LEVEL.

NOTE: ALL DIMENSIONS ARE NOMINAL

The Meadowlands (A-2)  
Madison, WI  
DATE: 01/29/2019  
DRAWN: BA  
PROJECT #: Tool  
CHECKED: ---

REV	DRW	CHK	DESCRIPTION

THIS DRAWING HAS BEEN PREPARED BASED ON INFORMATION PROVIDED TO ADS UNDER THE DIRECTION OF THE SITE DESIGN ENGINEER OR OTHER PROJECT REPRESENTATIVE. THE SITE DESIGN ENGINEER SHALL REVIEW THIS DRAWING PRIOR TO CONSTRUCTION. IT IS THE ULTIMATE RESPONSIBILITY OF THE SITE DESIGN ENGINEER TO ENSURE THAT THE PRODUCT(S) DEPICTED AND ALL ASSOCIATED DETAILS MEET ALL APPLICABLE LAWS, REGULATIONS, AND PROJECT REQUIREMENTS.



ADVANCED DRAINAGE SYSTEMS, INC.

**SiteASSIST™**  
by StormTech  
FOR STORMTECH  
INSTRUCTIONS,  
DOWNLOAD THE  
INSTALLATION APP



# The Meadowlands (A-3)

Madison, WI

## STORMTECH CHAMBER SPECIFICATIONS

1. CHAMBERS SHALL BE STORMTECH SC-740, SC-310, OR APPROVED EQUAL.
2. CHAMBERS SHALL BE MANUFACTURED FROM VIRGIN POLYPROPYLENE OR POLYETHYLENE RESINS.
3. CHAMBER ROWS SHALL PROVIDE CONTINUOUS, UNOBSTRUCTED INTERNAL SPACE WITH NO INTERNAL SUPPORT PANELS THAT WOULD IMPEDE FLOW OR LIMIT ACCESS FOR INSPECTION.
4. THE STRUCTURAL DESIGN OF THE CHAMBERS, THE STRUCTURAL BACKFILL, AND THE INSTALLATION REQUIREMENTS SHALL ENSURE THAT THE LOAD FACTORS SPECIFIED IN THE AASHTO LRFD BRIDGE DESIGN SPECIFICATIONS, SECTION 12.12, ARE MET FOR: 1) LONG-DURATION DEAD LOADS AND 2) SHORT-DURATION LIVE LOADS, BASED ON THE AASHTO DESIGN TRUCK WITH CONSIDERATION FOR IMPACT AND MULTIPLE VEHICLE PRESENCES.
5. CHAMBERS SHALL MEET ASTM F2922 (POLYETHYLENE) OR ASTM F2418 (POLYPROPYLENE), "STANDARD SPECIFICATION FOR THERMOPLASTIC CORRUGATED WALL STORMWATER COLLECTION CHAMBERS".
6. CHAMBERS SHALL BE DESIGNED AND ALLOWABLE LOADS DETERMINED IN ACCORDANCE WITH ASTM F2787, "STANDARD PRACTICE FOR STRUCTURAL DESIGN OF THERMOPLASTIC CORRUGATED WALL STORMWATER COLLECTION CHAMBERS".
7. ONLY CHAMBERS THAT ARE APPROVED BY THE SITE DESIGN ENGINEER WILL BE ALLOWED. THE CHAMBER MANUFACTURER SHALL SUBMIT THE FOLLOWING UPON REQUEST TO THE SITE DESIGN ENGINEER FOR APPROVAL BEFORE DELIVERING CHAMBERS TO THE PROJECT SITE:
  - a. A STRUCTURAL EVALUATION SEALED BY A REGISTERED PROFESSIONAL ENGINEER THAT DEMONSTRATES THAT THE SAFETY FACTORS ARE GREATER THAN OR EQUAL TO 1.95 FOR DEAD LOAD AND 1.75 FOR LIVE LOAD, THE MINIMUM REQUIRED BY ASTM F2787 AND BY AASHTO FOR THERMOPLASTIC PIPE.
  - b. A STRUCTURAL EVALUATION SEALED BY A REGISTERED PROFESSIONAL ENGINEER THAT DEMONSTRATES THAT THE LOAD FACTORS SPECIFIED IN THE AASHTO LRFD BRIDGE DESIGN SPECIFICATIONS, SECTION 12.12, ARE MET. THE 50 YEAR CREEP MODULUS DATA SPECIFIED IN ASTM F2418 OR ASTM F2922 MUST BE USED AS PART OF THE AASHTO STRUCTURAL EVALUATION TO VERIFY LONG-TERM PERFORMANCE.
  - c. STRUCTURAL CROSS SECTION DETAIL ON WHICH THE STRUCTURAL EVALUATION IS BASED.
8. CHAMBERS AND END CAPS SHALL BE PRODUCED AT AN ISO 9001 CERTIFIED MANUFACTURING FACILITY.

## IMPORTANT - NOTES FOR THE BIDDING AND INSTALLATION OF THE SC-310/SC-740 SYSTEM

1. STORMTECH SC-310 & SC-740 CHAMBERS SHALL NOT BE INSTALLED UNTIL THE MANUFACTURER'S REPRESENTATIVE HAS COMPLETED A PRE-CONSTRUCTION MEETING WITH THE INSTALLERS.
2. STORMTECH SC-310 & SC-740 CHAMBERS SHALL BE INSTALLED IN ACCORDANCE WITH THE "STORMTECH SC-310/SC-740/SC-780 CONSTRUCTION GUIDE".
3. CHAMBERS ARE NOT TO BE BACKFILLED WITH A DOZER OR AN EXCAVATOR SITUATED OVER THE CHAMBERS.  
  
STORMTECH RECOMMENDS 3 BACKFILL METHODS:
  - STONESHOOTER LOCATED OFF THE CHAMBER BED.
  - BACKFILL AS ROWS ARE BUILT USING AN EXCAVATOR ON THE FOUNDATION STONE OR SUBGRADE.
  - BACKFILL FROM OUTSIDE THE EXCAVATION USING A LONG BOOM HOE OR EXCAVATOR.
4. THE FOUNDATION STONE SHALL BE LEVELED AND COMPACTED PRIOR TO PLACING CHAMBERS.
5. JOINTS BETWEEN CHAMBERS SHALL BE PROPERLY SEATED PRIOR TO PLACING STONE.
6. MAINTAIN MINIMUM - 6" (150 mm) SPACING BETWEEN THE CHAMBER ROWS.
7. EMBEDMENT STONE SURROUNDING CHAMBERS MUST BE A CLEAN, CRUSHED, ANGULAR STONE 3/4-2" (20-50 mm).
8. THE CONTRACTOR MUST REPORT ANY DISCREPANCIES WITH CHAMBER FOUNDATION MATERIALS BEARING CAPACITIES TO THE SITE DESIGN ENGINEER.
9. ADS RECOMMENDS THE USE OF "FLEXSTORM CATCH IT" INSERTS DURING CONSTRUCTION FOR ALL INLETS TO PROTECT THE SUBSURFACE STORMWATER MANAGEMENT SYSTEM FROM CONSTRUCTION SITE RUNOFF.

## NOTES FOR CONSTRUCTION EQUIPMENT

1. STORMTECH SC-310 & SC-740 CHAMBERS SHALL BE INSTALLED IN ACCORDANCE WITH THE "STORMTECH SC-310/SC-740/DC-780 CONSTRUCTION GUIDE".
2. THE USE OF CONSTRUCTION EQUIPMENT OVER SC-310 & SC-740 CHAMBERS IS LIMITED:
  - NO EQUIPMENT IS ALLOWED ON BARE CHAMBERS.
  - NO RUBBER Tired LOADERS, DUMP TRUCKS, OR EXCAVATORS ARE ALLOWED UNTIL PROPER FILL DEPTHS ARE REACHED IN ACCORDANCE WITH THE "STORMTECH SC-310/SC-740/DC-780 CONSTRUCTION GUIDE".
  - WEIGHT LIMITS FOR CONSTRUCTION EQUIPMENT CAN BE FOUND IN THE "STORMTECH SC-310/SC-740/DC-780 CONSTRUCTION GUIDE".
3. FULL 36" (900 mm) OF STABILIZED COVER MATERIALS OVER THE CHAMBERS IS REQUIRED FOR DUMP TRUCK TRAVEL OR DUMPING.

**USE OF A DOZER TO PUSH EMBEDMENT STONE BETWEEN THE ROWS OF CHAMBERS MAY CAUSE DAMAGE TO THE CHAMBERS AND IS NOT AN ACCEPTABLE BACKFILL METHOD. ANY CHAMBERS DAMAGED BY THE "DUMP AND PUSH" METHOD ARE NOT COVERED UNDER THE STORMTECH STANDARD WARRANTY.**

CONTACT STORMTECH AT 1-888-892-2694 WITH ANY QUESTIONS ON INSTALLATION REQUIREMENTS OR WEIGHT LIMITS FOR CONSTRUCTION EQUIPMENT.

**CONCEPTUAL LAYOUT**

(63) STORMTECH SC-310 CHAMBERS  
 (6) STORMTECH SC-310 END CAPS  
 INSTALLED WITH 6" COVER STONE, 24" BASE STONE, 40% STONE VOID  
**INSTALLED SYSTEM VOLUME: 3485 CF**  
 AREA OF SYSTEM: 1909 FT<sup>2</sup>  
 PERIMETER OF SYSTEM: 344 FT

**COMPUTER GENERATED CONCEPTUAL LAYOUT - NOT FOR CONSTRUCTION**

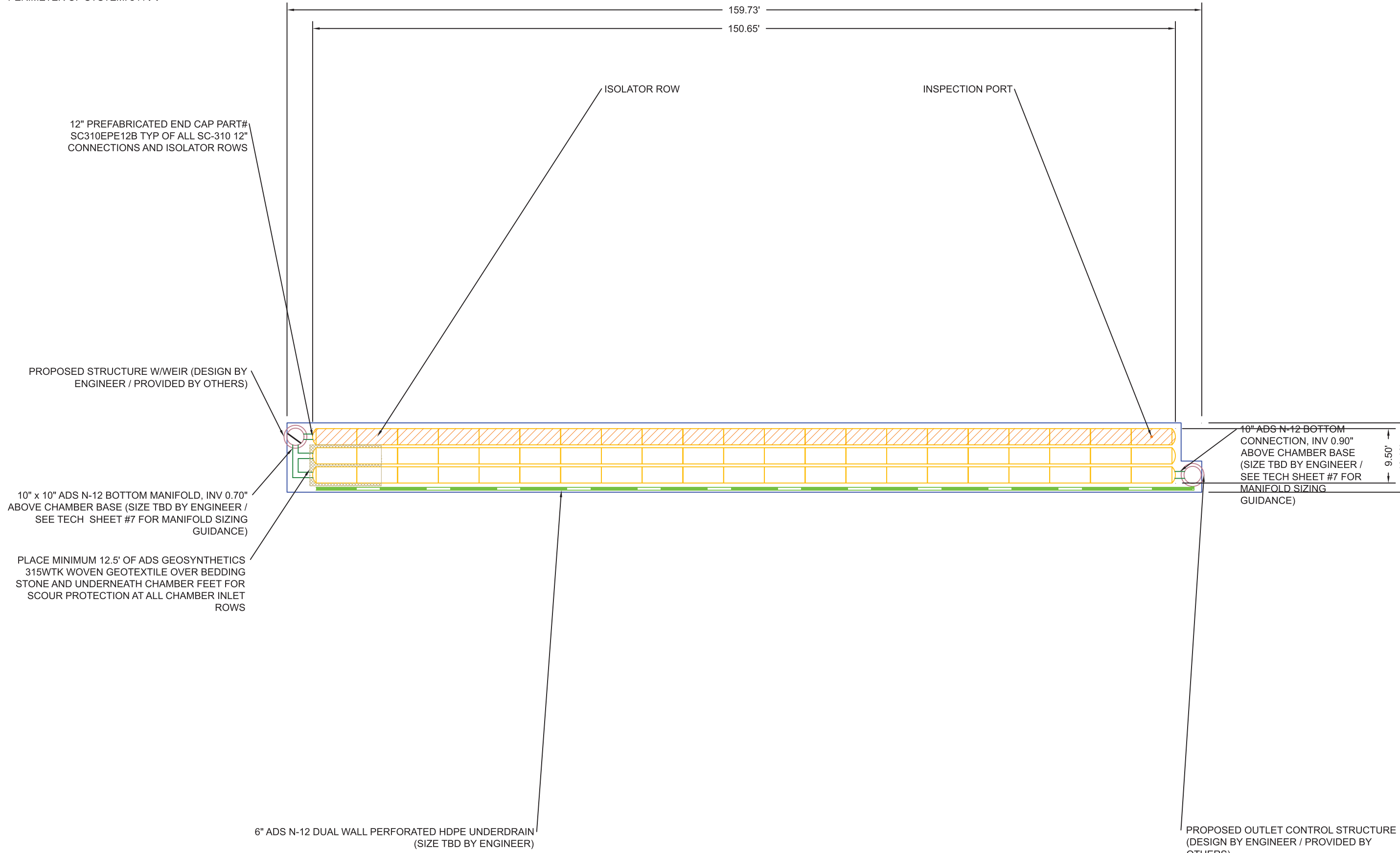

12" PREFABRICATED END CAP PART# SC310EPE12B TYP OF ALL SC-310 12" CONNECTIONS AND ISOLATOR ROWS

PROPOSED STRUCTURE W/WEIR (DESIGN BY ENGINEER / PROVIDED BY OTHERS)

10" x 10" ADS N-12 BOTTOM MANIFOLD, INV 0.70" ABOVE CHAMBER BASE (SIZE TBD BY ENGINEER / SEE TECH SHEET #7 FOR MANIFOLD SIZING GUIDANCE)

PLACE MINIMUM 12.5' OF ADS GEOSYNTHETICS 315WTK WOVEN GEOTEXTILE OVER BEDDING STONE AND UNDERNEATH CHAMBER FEET FOR SCOUR PROTECTION AT ALL CHAMBER INLET ROWS

6" ADS N-12 DUAL WALL PERFORATED HDPE UNDERDRAIN (SIZE TBD BY ENGINEER)

PROPOSED OUTLET CONTROL STRUCTURE (DESIGN BY ENGINEER / PROVIDED BY OTHERS)

The Meadowlands (A-3)	
Madison, WI	
DATE: 01/29/2019	DRAWN: BA
PROJECT #: Tool	CHECKED: ---

REV	DRW	CHK	DESCRIPTION

**StormTech**  
 Retention - Water Quality  
 70 NWWOOD ROAD, SUITE 3 | ROCKY HILL, CT | 06067  
 860-529-8188 | 866-892-2694 | WWW.STORMTECH.COM

**ADS**  
 ADVANCED DRAINAGE SYSTEMS, INC.  
 4640 TRUEMAN BLVD  
 HILLIARD, OH 43026  
 1-800-733-7473

**NOT TO SCALE**

THIS DRAWING HAS BEEN PREPARED BASED ON INFORMATION PROVIDED TO ADS UNDER THE DIRECTION OF THE SITE DESIGN ENGINEER OR OTHER PROJECT REPRESENTATIVE. THE SITE DESIGN ENGINEER SHALL REVIEW THIS DRAWING PRIOR TO CONSTRUCTION. IT IS THE ULTIMATE RESPONSIBILITY OF THE SITE DESIGN ENGINEER TO ENSURE THAT THE PRODUCT(S) DEPICTED AND ALL ASSOCIATED DETAILS MEET ALL APPLICABLE LAWS, REGULATIONS, AND PROJECT REQUIREMENTS.

## ACCEPTABLE FILL MATERIALS: STORMTECH SC-310 CHAMBER SYSTEMS

MATERIAL LOCATION	DESCRIPTION	AASHTO MATERIAL CLASSIFICATIONS	COMPACTION / DENSITY REQUIREMENT
D	<b>FINAL FILL:</b> FILL MATERIAL FOR LAYER 'D' STARTS FROM THE TOP OF THE 'C' LAYER TO THE BOTTOM OF FLEXIBLE PAVEMENT OR UNPAVED FINISHED GRADE ABOVE. NOTE THAT PAVEMENT SUBBASE MAY BE PART OF THE 'D' LAYER	N/A	PREPARE PER SITE DESIGN ENGINEER'S PLANS. PAVED INSTALLATIONS MAY HAVE STRINGENT MATERIAL AND PREPARATION REQUIREMENTS.
C	<b>INITIAL FILL:</b> FILL MATERIAL FOR LAYER 'C' STARTS FROM THE TOP OF THE EMBEDMENT STONE ('B' LAYER) TO 18" (450 mm) ABOVE THE TOP OF THE CHAMBER. NOTE THAT PAVEMENT SUBBASE MAY BE A PART OF THE 'C' LAYER.	AASHTO M145 <sup>1</sup> A-1, A-2-4, A-3  OR AASHTO M43 <sup>1</sup> 3, 357, 4, 467, 5, 56, 57, 6, 67, 68, 7, 78, 8, 89, 9, 10	BEGIN COMPACTIONS AFTER 12" (300 mm) OF MATERIAL OVER THE CHAMBERS IS REACHED. COMPACT ADDITIONAL LAYERS IN 6" (150 mm) MAX LIFTS TO A MIN. 95% PROCTOR DENSITY FOR WELL GRADED MATERIAL AND 95% RELATIVE DENSITY FOR PROCESSED AGGREGATE MATERIALS. ROLLER GROSS VEHICLE WEIGHT NOT TO EXCEED 12,000 lbs (53 kN). DYNAMIC FORCE NOT TO EXCEED 20,000 lbs (89 kN).
B	<b>EMBEDMENT STONE:</b> FILL SURROUNDING THE CHAMBERS FROM THE FOUNDATION STONE ('A' LAYER) TO THE 'C' LAYER ABOVE.	AASHTO M43 <sup>1</sup> 3, 357, 4, 467, 5, 56, 57	NO COMPACTION REQUIRED.
A	<b>FOUNDATION STONE:</b> FILL BELOW CHAMBERS FROM THE SUBGRADE UP TO THE FOOT (BOTTOM) OF THE CHAMBER.	AASHTO M43 <sup>1</sup> 3, 357, 4, 467, 5, 56, 57	PLATE COMPACT OR ROLL TO ACHIEVE A FLAT SURFACE. <sup>2 3</sup>

**PLEASE NOTE:**

- THE LISTED AASHTO DESIGNATIONS ARE FOR GRADATIONS ONLY. THE STONE MUST ALSO BE CLEAN, CRUSHED, ANGULAR. FOR EXAMPLE, A SPECIFICATION FOR #4 STONE WOULD STATE: "CLEAN, CRUSHED, ANGULAR NO. 4 (AASHTO M43) STONE".
- STORMTECH COMPACTION REQUIREMENTS ARE MET FOR 'A' LOCATION MATERIALS WHEN PLACED AND COMPACTED IN 6" (150 mm) (MAX) LIFTS USING TWO FULL COVERAGES WITH A VIBRATORY COMPACTOR.
- WHERE INFILTRATION SURFACES MAY BE COMPROMISED BY COMPACTION, FOR STANDARD DESIGN LOAD CONDITIONS, A FLAT SURFACE MAY BE ACHIEVED BY RAKING OR DRAGGING WITHOUT COMPACTION EQUIPMENT. FOR SPECIAL LOAD DESIGNS, CONTACT STORMTECH FOR COMPACTION REQUIREMENTS.

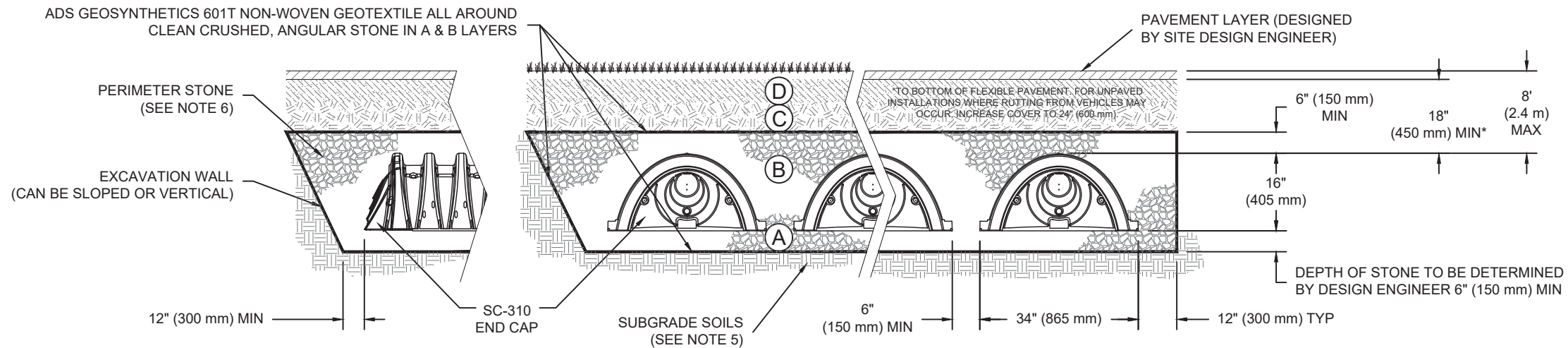

**NOTES:**

- SC-310 CHAMBERS SHALL CONFORM TO THE REQUIREMENTS OF ASTM F2418 "STANDARD SPECIFICATION FOR POLYPROPYLENE (PP) CORRUGATED WALL STORMWATER COLLECTION CHAMBERS", OR ASTM F2922 "STANDARD SPECIFICATION FOR POLYETHYLENE (PE) CORRUGATED WALL STORMWATER COLLECTION CHAMBERS".
- SC-310 CHAMBERS SHALL BE DESIGNED IN ACCORDANCE WITH ASTM F2787 "STANDARD PRACTICE FOR STRUCTURAL DESIGN OF THERMOPLASTIC CORRUGATED WALL STORMWATER COLLECTION CHAMBERS".
- "ACCEPTABLE FILL MATERIALS" TABLE ABOVE PROVIDES MATERIAL LOCATIONS, DESCRIPTIONS, GRADATIONS, AND COMPACTION REQUIREMENTS FOR FOUNDATION, EMBEDMENT, AND FILL MATERIALS.
- THE "SITE DESIGN ENGINEER" REFERS TO THE ENGINEER RESPONSIBLE FOR THE DESIGN AND LAYOUT OF THE STORMTECH CHAMBERS FOR THIS PROJECT.
- THE SITE DESIGN ENGINEER IS RESPONSIBLE FOR ASSESSING THE BEARING RESISTANCE (ALLOWABLE BEARING CAPACITY) OF THE SUBGRADE SOILS AND THE DEPTH OF FOUNDATION STONE WITH CONSIDERATION FOR THE RANGE OF EXPECTED SOIL MOISTURE CONDITIONS.
- PERIMETER STONE MUST BE EXTENDED HORIZONTALLY TO THE EXCAVATION WALL FOR BOTH VERTICAL AND SLOPED EXCAVATION WALLS.
- ONCE LAYER 'C' IS PLACED, ANY SOIL/MATERIAL CAN BE PLACED IN LAYER 'D' UP TO THE FINISHED GRADE. MOST PAVEMENT SUBBASE SOILS CAN BE USED TO REPLACE THE MATERIAL REQUIREMENTS OF LAYER 'C' OR 'D' AT THE SITE DESIGN ENGINEER'S DISCRETION.

<b>The Meadowlands (A-3)</b> Madison, WI	DATE: 01/29/2019 DRAWN: BA PROJECT #: Tool CHECKED: ---	
DESCRIPTION	CHK	DRW
REV	REV	REV
 70 INWOOD ROAD, SUITE 3   ROCKY HILL   CT   06867 860-525-8188   888-892-2694   WWW.STORMTECH.COM		
4640 TRUEMAN BLVD HILLIARD, OH 43026 1-800-733-7473  ADVANCED DRAINAGE SYSTEMS, INC.		
THIS DRAWING HAS BEEN PREPARED BASED ON INFORMATION PROVIDED TO ADS UNDER THE DIRECTION OF THE SITE DESIGN ENGINEER OR OTHER PROJECT REPRESENTATIVE. THE SITE DESIGN ENGINEER SHALL REVIEW THIS DRAWING PRIOR TO CONSTRUCTION. IT IS THE ULTIMATE RESPONSIBILITY OF THE SITE DESIGN ENGINEER TO ENSURE THAT THE PRODUCT(S) DEPICTED AND ALL ASSOCIATED DETAILS MEET ALL APPLICABLE LAWS, REGULATIONS, AND PROJECT REQUIREMENTS.		
SHEET <b>3 OF 5</b>		

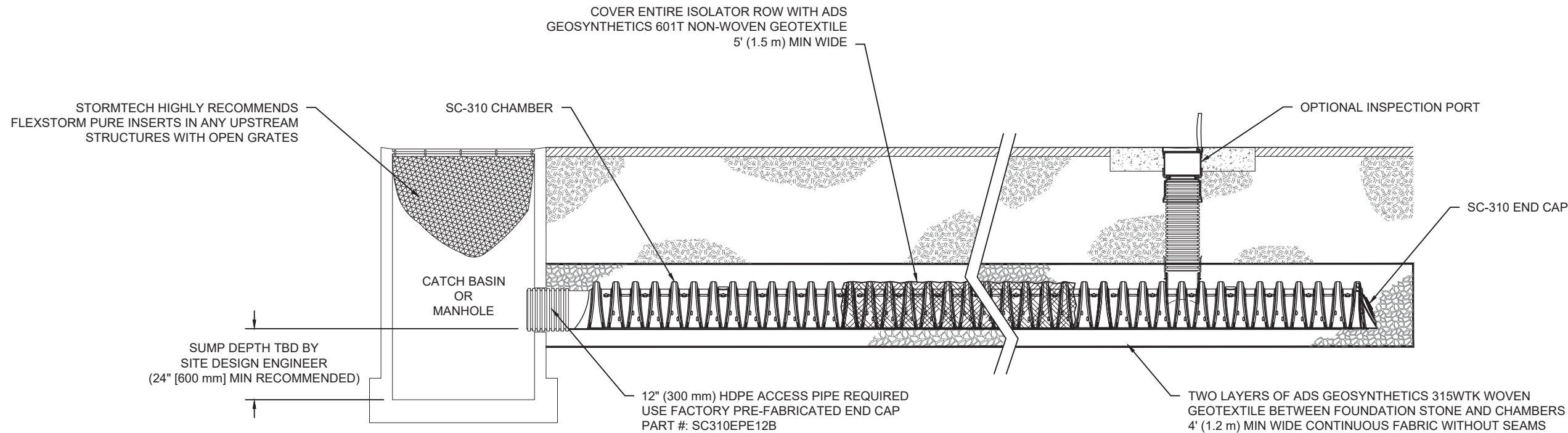

**SC-310 ISOLATOR ROW DETAIL**  
NTS

**INSPECTION & MAINTENANCE**

- STEP 1) INSPECT ISOLATOR ROW FOR SEDIMENT
- A. INSPECTION PORTS (IF PRESENT)
    - A.1. REMOVE/OPEN LID ON NYLOPLAST INLINE DRAIN
    - A.2. REMOVE AND CLEAN FLEXSTORM FILTER IF INSTALLED
    - A.3. USING A FLASHLIGHT AND STADIA ROD, MEASURE DEPTH OF SEDIMENT AND RECORD ON MAINTENANCE LOG
    - A.4. LOWER A CAMERA INTO ISOLATOR ROW FOR VISUAL INSPECTION OF SEDIMENT LEVELS (OPTIONAL)
    - A.5. IF SEDIMENT IS AT, OR ABOVE, 3" (80 mm) PROCEED TO STEP 2. IF NOT, PROCEED TO STEP 3.
  - B. ALL ISOLATOR ROWS
    - B.1. REMOVE COVER FROM STRUCTURE AT UPSTREAM END OF ISOLATOR ROW
    - B.2. USING A FLASHLIGHT, INSPECT DOWN THE ISOLATOR ROW THROUGH OUTLET PIPE
      - i) MIRRORS ON POLES OR CAMERAS MAY BE USED TO AVOID A CONFINED SPACE ENTRY
      - ii) FOLLOW OSHA REGULATIONS FOR CONFINED SPACE ENTRY IF ENTERING MANHOLE
    - B.3. IF SEDIMENT IS AT, OR ABOVE, 3" (80 mm) PROCEED TO STEP 2. IF NOT, PROCEED TO STEP 3.
- STEP 2) CLEAN OUT ISOLATOR ROW USING THE JETVAC PROCESS
- A. A FIXED CULVERT CLEANING NOZZLE WITH REAR FACING SPREAD OF 45" (1.1 m) OR MORE IS PREFERRED
  - B. APPLY MULTIPLE PASSES OF JETVAC UNTIL BACKFLUSH WATER IS CLEAN
  - C. VACUUM STRUCTURE SUMP AS REQUIRED
- STEP 3) REPLACE ALL COVERS, GRATES, FILTERS, AND LIDS; RECORD OBSERVATIONS AND ACTIONS.
- STEP 4) INSPECT AND CLEAN BASINS AND MANHOLES UPSTREAM OF THE STORMTECH SYSTEM.

**NOTES**

1. INSPECT EVERY 6 MONTHS DURING THE FIRST YEAR OF OPERATION. ADJUST THE INSPECTION INTERVAL BASED ON PREVIOUS OBSERVATIONS OF SEDIMENT ACCUMULATION AND HIGH WATER ELEVATIONS.
2. CONDUCT JETTING AND VACTORING ANNUALLY OR WHEN INSPECTION SHOWS THAT MAINTENANCE IS NECESSARY.

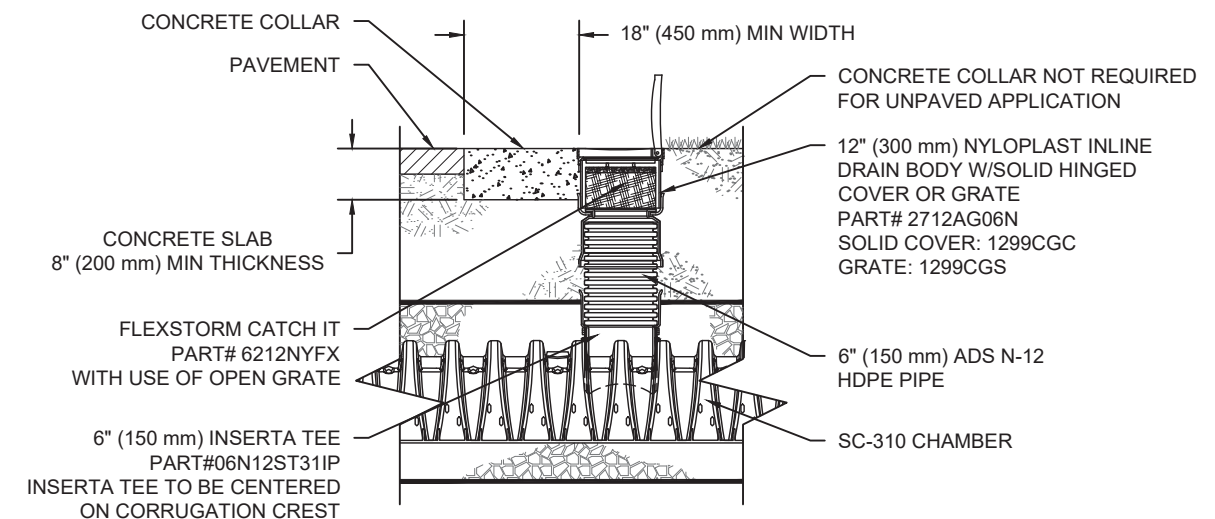

**SC-310 6" INSPECTION PORT DETAIL**  
NTS

The Meadowlands (A-3)	
Madison, WI	
DATE: 01/29/2019	DRAWN: BA
PROJECT #: Tool	CHECKED: ---

REV	DRW	CHK	DESCRIPTION

70 INWOOD ROAD, SUITE 3 | ROCKY HILL | CT | 06067  
860-525-8188 | 888-892-2694 | WWW.STORMTECH.COM

4640 TRUJEMAN BLVD  
HILLIARD, OH 43026  
1-800-733-7473

THIS DRAWING HAS BEEN PREPARED BASED ON INFORMATION PROVIDED TO ADS UNDER THE DIRECTION OF THE SITE DESIGN ENGINEER OR OTHER PROJECT REPRESENTATIVE. THE SITE DESIGN ENGINEER SHALL REVIEW THIS DRAWING PRIOR TO CONSTRUCTION. IT IS THE ULTIMATE RESPONSIBILITY OF THE SITE DESIGN ENGINEER TO ENSURE THAT THE PRODUCT(S) DEPICTED AND ALL ASSOCIATED DETAILS MEET ALL APPLICABLE LAWS, REGULATIONS, AND PROJECT REQUIREMENTS.

**UNDERDRAIN DETAIL**

NTS

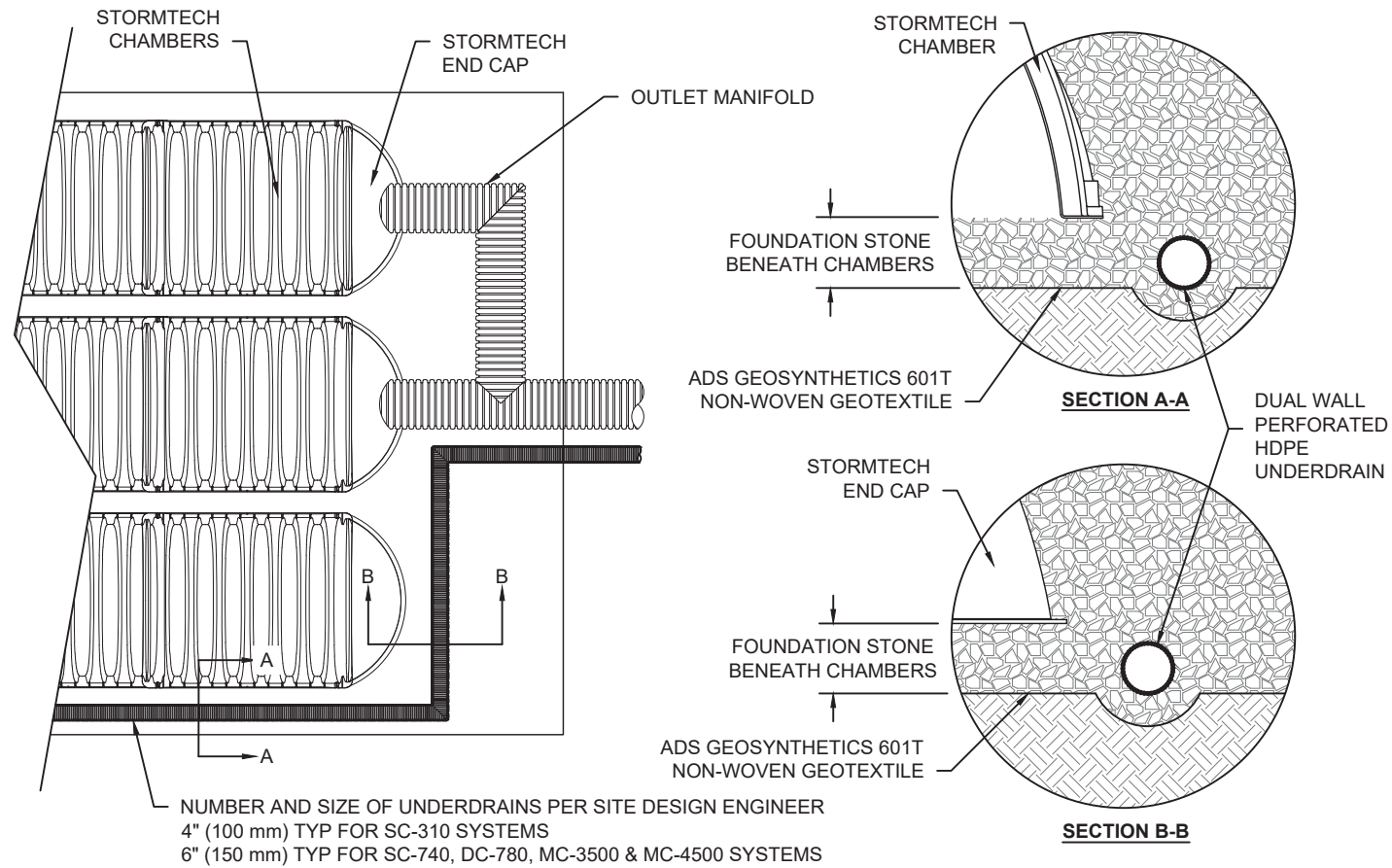

NUMBER AND SIZE OF UNDERDRAINS PER SITE DESIGN ENGINEER  
 4" (100 mm) TYP FOR SC-310 SYSTEMS  
 6" (150 mm) TYP FOR SC-740, DC-780, MC-3500 & MC-4500 SYSTEMS

**SC-310 TECHNICAL SPECIFICATION**

NTS

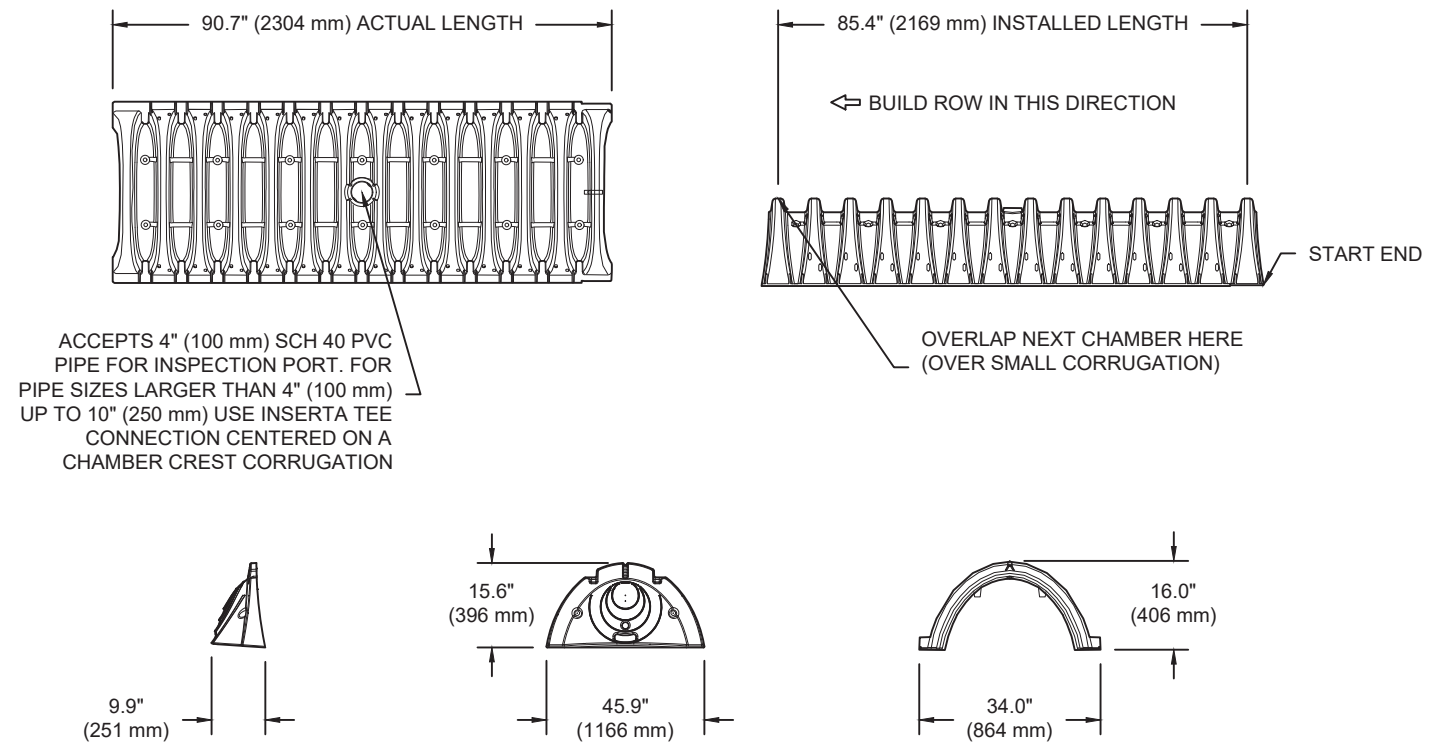

ACCEPTS 4" (100 mm) SCH 40 PVC PIPE FOR INSPECTION PORT. FOR PIPE SIZES LARGER THAN 4" (100 mm) UP TO 10" (250 mm) USE INSERTA TEE CONNECTION CENTERED ON A CHAMBER CREST CORRUGATION

**NOMINAL CHAMBER SPECIFICATIONS**

SIZE (W X H X INSTALLED LENGTH)	34.0" X 16.0" X 85.4"	(864 mm X 406 mm X 2169 mm)
CHAMBER STORAGE	14.7 CUBIC FEET	(0.42 m <sup>3</sup> )
MINIMUM INSTALLED STORAGE*	31.0 CUBIC FEET	(0.88 m <sup>3</sup> )
WEIGHT	35.0 lbs.	(16.8 kg)

\*ASSUMES 6" (152 mm) ABOVE, BELOW, AND BETWEEN CHAMBERS

**INSERTA TEE DETAIL**

NTS

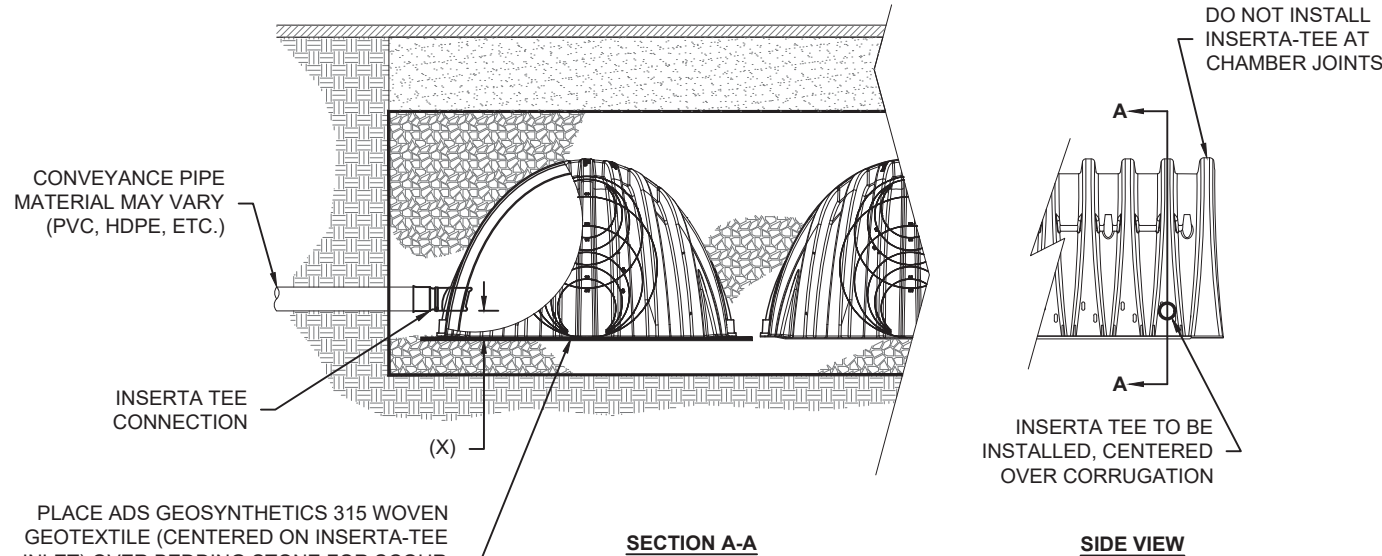

PLACE ADS GEOSYNTHETICS 315 WOVEN GEOTEXTILE (CENTERED ON INSERTA-TEE INLET) OVER BEDDING STONE FOR SCOUR PROTECTION AT SIDE INLET CONNECTIONS. GEOTEXTILE MUST EXTEND 6" (150 mm) PAST CHAMBER FOOT

**SECTION A-A**

**SIDE VIEW**

CHAMBER	MAX DIAMETER OF INSERTA TEE	HEIGHT FROM BASE OF CHAMBER (X)
SC-310	6" (150 mm)	4" (100 mm)
SC-740	10" (250 mm)	4" (100 mm)
DC-780	10" (250 mm)	4" (100 mm)
MC-3500	12" (300 mm)	6" (150 mm)
MC-4500	12" (300 mm)	8" (200 mm)

INSERTA TEE FITTINGS AVAILABLE FOR SDR 26, SDR 35, SCH 40 IPS GASKETED & SOLVENT WELD, N-12, HP STORM, C-900 OR DUCTILE IRON

STUBS AT BOTTOM OF END CAP FOR PART NUMBERS ENDING WITH "B"  
 STUBS AT TOP OF END CAP FOR PART NUMBERS ENDING WITH "T"

PART #	STUB	A	B	C
SC310EPE06T / SC310EPE06TPC	6" (150 mm)	9.6" (244 mm)	5.8" (147 mm)	---
SC310EPE06B / SC310EPE06BPC			---	0.5" (13 mm)
SC310EPE08T / SC310EPE08TPC	8" (200 mm)	11.9" (302 mm)	3.5" (89 mm)	---
SC310EPE08B / SC310EPE08BPC			---	0.6" (15 mm)
SC310EPE10T / SC310EPE10TPC	10" (250 mm)	12.7" (323 mm)	1.4" (36 mm)	---
SC310EPE10B / SC310EPE10BPC			---	0.7" (18 mm)
SC310EPE12B	12" (300 mm)	13.5" (343 mm)	---	0.9" (23 mm)

ALL STUBS, EXCEPT FOR THE SC310EPE12B ARE PLACED AT BOTTOM OF END CAP SUCH THAT THE OUTSIDE DIAMETER OF THE STUB IS FLUSH WITH THE BOTTOM OF THE END CAP. FOR ADDITIONAL INFORMATION CONTACT STORMTECH AT 1-888-892-2694.

\* FOR THE SC310EPE12B THE 12" (300 mm) STUB LIES BELOW THE BOTTOM OF THE END CAP APPROXIMATELY 0.25" (6 mm). BACKFILL MATERIAL SHOULD BE REMOVED FROM BELOW THE N-12 STUB SO THAT THE FITTING SITS LEVEL.

NOTE: ALL DIMENSIONS ARE NOMINAL

**NOTE:**  
 PART NUMBERS WILL VARY BASED ON INLET PIPE MATERIALS. CONTACT STORMTECH FOR MORE INFORMATION.

The Meadowlands (A-3)  
 Madison, WI  
 DATE: 01/29/2019  
 DRAWN: BA  
 PROJECT #: Tool  
 CHECKED: ---

REV	DRW	CHK	DESCRIPTION

70 INWOOD ROAD, SUITE 3 | ROCKY HILL | CT | 06867  
 860-525-8188 | 888-892-2694 | WWW.STORMTECH.COM

4640 TRUEMAN BLVD  
 HILLIARD, OH 43026  
 1-800-733-7473  
**ADS**  
 ADVANCED DRAINAGE SYSTEMS, INC.

THIS DRAWING HAS BEEN PREPARED BASED ON INFORMATION PROVIDED TO ADS UNDER THE DIRECTION OF THE SITE DESIGN ENGINEER OR OTHER PROJECT REPRESENTATIVE. THE SITE DESIGN ENGINEER SHALL REVIEW THIS DRAWING PRIOR TO CONSTRUCTION. IT IS THE ULTIMATE RESPONSIBILITY OF THE SITE DESIGN ENGINEER TO ENSURE THAT THE PRODUCT(S) DEPICTED AND ALL ASSOCIATED DETAILS MEET ALL APPLICABLE LAWS, REGULATIONS, AND PROJECT REQUIREMENTS.



ADVANCED DRAINAGE SYSTEMS, INC.

**SiteASSIST™**  
by StormTech  
FOR STORMTECH  
INSTRUCTIONS,  
DOWNLOAD THE  
INSTALLATION APP



# The Meadowlands (A-4)

Madison, WI

## STORMTECH CHAMBER SPECIFICATIONS

1. CHAMBERS SHALL BE STORMTECH SC-740, SC-310, OR APPROVED EQUAL.
2. CHAMBERS SHALL BE MANUFACTURED FROM VIRGIN POLYPROPYLENE OR POLYETHYLENE RESINS.
3. CHAMBER ROWS SHALL PROVIDE CONTINUOUS, UNOBSTRUCTED INTERNAL SPACE WITH NO INTERNAL SUPPORT PANELS THAT WOULD IMPEDE FLOW OR LIMIT ACCESS FOR INSPECTION.
4. THE STRUCTURAL DESIGN OF THE CHAMBERS, THE STRUCTURAL BACKFILL, AND THE INSTALLATION REQUIREMENTS SHALL ENSURE THAT THE LOAD FACTORS SPECIFIED IN THE AASHTO LRFD BRIDGE DESIGN SPECIFICATIONS, SECTION 12.12, ARE MET FOR: 1) LONG-DURATION DEAD LOADS AND 2) SHORT-DURATION LIVE LOADS, BASED ON THE AASHTO DESIGN TRUCK WITH CONSIDERATION FOR IMPACT AND MULTIPLE VEHICLE PRESENCES.
5. CHAMBERS SHALL MEET ASTM F2922 (POLYETHYLENE) OR ASTM F2418 (POLYPROPYLENE), "STANDARD SPECIFICATION FOR THERMOPLASTIC CORRUGATED WALL STORMWATER COLLECTION CHAMBERS".
6. CHAMBERS SHALL BE DESIGNED AND ALLOWABLE LOADS DETERMINED IN ACCORDANCE WITH ASTM F2787, "STANDARD PRACTICE FOR STRUCTURAL DESIGN OF THERMOPLASTIC CORRUGATED WALL STORMWATER COLLECTION CHAMBERS".
7. ONLY CHAMBERS THAT ARE APPROVED BY THE SITE DESIGN ENGINEER WILL BE ALLOWED. THE CHAMBER MANUFACTURER SHALL SUBMIT THE FOLLOWING UPON REQUEST TO THE SITE DESIGN ENGINEER FOR APPROVAL BEFORE DELIVERING CHAMBERS TO THE PROJECT SITE:
  - a. A STRUCTURAL EVALUATION SEALED BY A REGISTERED PROFESSIONAL ENGINEER THAT DEMONSTRATES THAT THE SAFETY FACTORS ARE GREATER THAN OR EQUAL TO 1.95 FOR DEAD LOAD AND 1.75 FOR LIVE LOAD, THE MINIMUM REQUIRED BY ASTM F2787 AND BY AASHTO FOR THERMOPLASTIC PIPE.
  - b. A STRUCTURAL EVALUATION SEALED BY A REGISTERED PROFESSIONAL ENGINEER THAT DEMONSTRATES THAT THE LOAD FACTORS SPECIFIED IN THE AASHTO LRFD BRIDGE DESIGN SPECIFICATIONS, SECTION 12.12, ARE MET. THE 50 YEAR CREEP MODULUS DATA SPECIFIED IN ASTM F2418 OR ASTM F2922 MUST BE USED AS PART OF THE AASHTO STRUCTURAL EVALUATION TO VERIFY LONG-TERM PERFORMANCE.
  - c. STRUCTURAL CROSS SECTION DETAIL ON WHICH THE STRUCTURAL EVALUATION IS BASED.
8. CHAMBERS AND END CAPS SHALL BE PRODUCED AT AN ISO 9001 CERTIFIED MANUFACTURING FACILITY.

## IMPORTANT - NOTES FOR THE BIDDING AND INSTALLATION OF THE SC-310/SC-740 SYSTEM

1. STORMTECH SC-310 & SC-740 CHAMBERS SHALL NOT BE INSTALLED UNTIL THE MANUFACTURER'S REPRESENTATIVE HAS COMPLETED A PRE-CONSTRUCTION MEETING WITH THE INSTALLERS.
2. STORMTECH SC-310 & SC-740 CHAMBERS SHALL BE INSTALLED IN ACCORDANCE WITH THE "STORMTECH SC-310/SC-740/SC-780 CONSTRUCTION GUIDE".
3. CHAMBERS ARE NOT TO BE BACKFILLED WITH A DOZER OR AN EXCAVATOR SITUATED OVER THE CHAMBERS.  
  
STORMTECH RECOMMENDS 3 BACKFILL METHODS:
  - STONESHOOTER LOCATED OFF THE CHAMBER BED.
  - BACKFILL AS ROWS ARE BUILT USING AN EXCAVATOR ON THE FOUNDATION STONE OR SUBGRADE.
  - BACKFILL FROM OUTSIDE THE EXCAVATION USING A LONG BOOM HOE OR EXCAVATOR.
4. THE FOUNDATION STONE SHALL BE LEVELED AND COMPACTED PRIOR TO PLACING CHAMBERS.
5. JOINTS BETWEEN CHAMBERS SHALL BE PROPERLY SEATED PRIOR TO PLACING STONE.
6. MAINTAIN MINIMUM - 6" (150 mm) SPACING BETWEEN THE CHAMBER ROWS.
7. EMBEDMENT STONE SURROUNDING CHAMBERS MUST BE A CLEAN, CRUSHED, ANGULAR STONE 3/4-2" (20-50 mm).
8. THE CONTRACTOR MUST REPORT ANY DISCREPANCIES WITH CHAMBER FOUNDATION MATERIALS BEARING CAPACITIES TO THE SITE DESIGN ENGINEER.
9. ADS RECOMMENDS THE USE OF "FLEXSTORM CATCH IT" INSERTS DURING CONSTRUCTION FOR ALL INLETS TO PROTECT THE SUBSURFACE STORMWATER MANAGEMENT SYSTEM FROM CONSTRUCTION SITE RUNOFF.

## NOTES FOR CONSTRUCTION EQUIPMENT

1. STORMTECH SC-310 & SC-740 CHAMBERS SHALL BE INSTALLED IN ACCORDANCE WITH THE "STORMTECH SC-310/SC-740/DC-780 CONSTRUCTION GUIDE".
2. THE USE OF CONSTRUCTION EQUIPMENT OVER SC-310 & SC-740 CHAMBERS IS LIMITED:
  - NO EQUIPMENT IS ALLOWED ON BARE CHAMBERS.
  - NO RUBBER Tired LOADERS, DUMP TRUCKS, OR EXCAVATORS ARE ALLOWED UNTIL PROPER FILL DEPTHS ARE REACHED IN ACCORDANCE WITH THE "STORMTECH SC-310/SC-740/DC-780 CONSTRUCTION GUIDE".
  - WEIGHT LIMITS FOR CONSTRUCTION EQUIPMENT CAN BE FOUND IN THE "STORMTECH SC-310/SC-740/DC-780 CONSTRUCTION GUIDE".
3. FULL 36" (900 mm) OF STABILIZED COVER MATERIALS OVER THE CHAMBERS IS REQUIRED FOR DUMP TRUCK TRAVEL OR DUMPING.

**USE OF A DOZER TO PUSH EMBEDMENT STONE BETWEEN THE ROWS OF CHAMBERS MAY CAUSE DAMAGE TO THE CHAMBERS AND IS NOT AN ACCEPTABLE BACKFILL METHOD. ANY CHAMBERS DAMAGED BY THE "DUMP AND PUSH" METHOD ARE NOT COVERED UNDER THE STORMTECH STANDARD WARRANTY.**

CONTACT STORMTECH AT 1-888-892-2694 WITH ANY QUESTIONS ON INSTALLATION REQUIREMENTS OR WEIGHT LIMITS FOR CONSTRUCTION EQUIPMENT.



**CONCEPTUAL LAYOUT**

(55) STORMTECH SC-310 CHAMBERS  
 (10) STORMTECH SC-310 END CAPS  
 INSTALLED WITH 6" COVER STONE, 24" BASE STONE, 40% STONE VOID  
**INSTALLED SYSTEM VOLUME: 2962 CF**  
 AREA OF SYSTEM: 1614 FT<sup>2</sup>  
 PERIMETER OF SYSTEM: 215 FT

**COMPUTER GENERATED CONCEPTUAL LAYOUT - NOT FOR CONSTRUCTION**

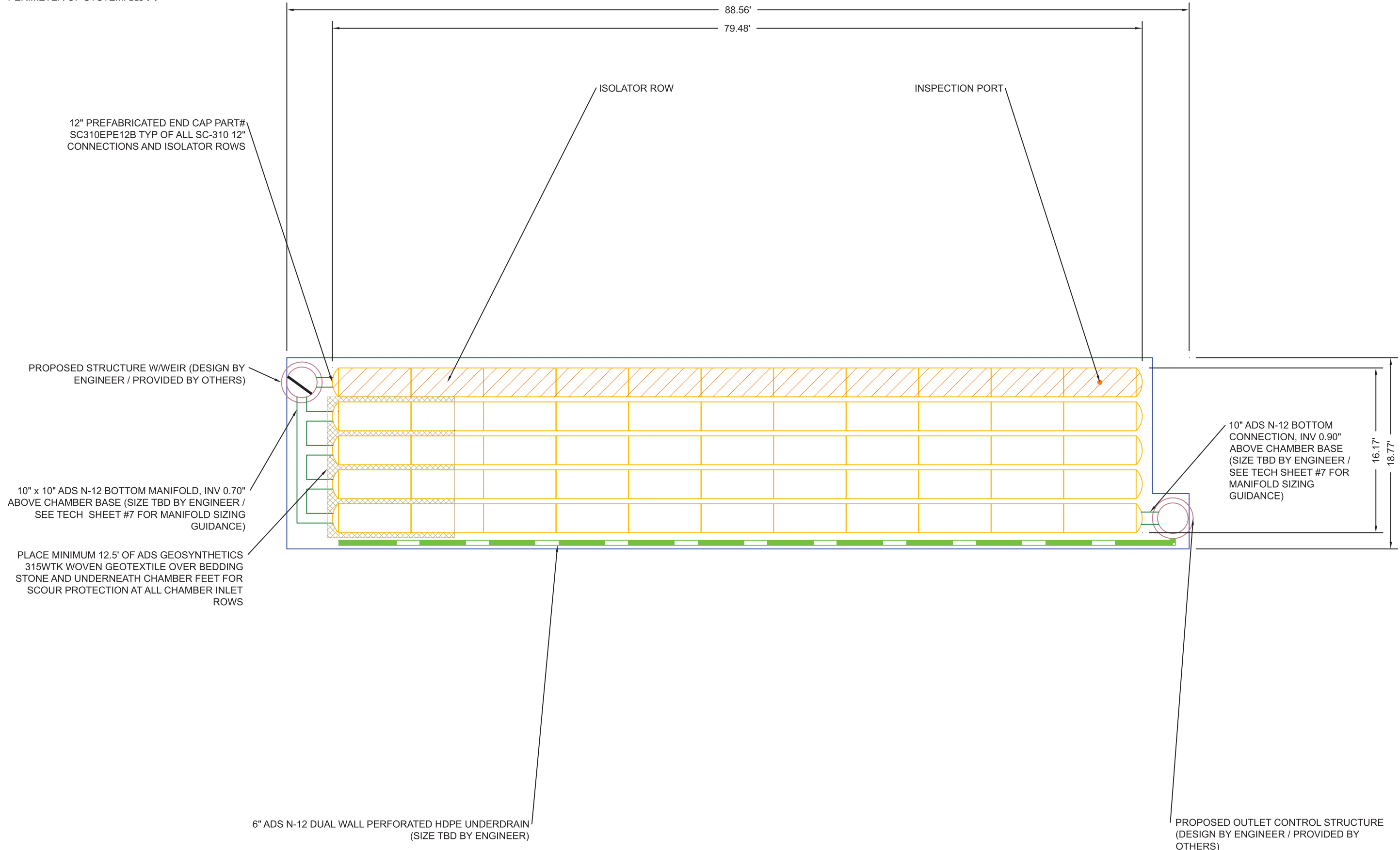

The Meadowlands (A-4) Madison, WI		DATE: 01/29/2019	DRAWN: BA
		PROJECT #: Tool	CHECKED: ---
REV	DRW	CHK	DESCRIPTION

**StormTech**  
 Retention - Water Quality  
 70 NWWOOD ROAD, SUITE 3 | ROCKY HILL, CT | 06067  
 860-529-8188 | 868-892-2694 | WWW.STORMTECH.COM

4640 TRUEMAN BLVD  
 HILLIARD, OH 43026  
 1-800-733-7473

**ADS**  
 ADVANCED DRAINAGE SYSTEMS, INC.

**NOT TO SCALE**

THIS DRAWING HAS BEEN PREPARED BASED ON INFORMATION PROVIDED TO ADS UNDER THE DIRECTION OF THE SITE DESIGN ENGINEER OR OTHER PROJECT REPRESENTATIVE. THE SITE DESIGN ENGINEER SHALL REVIEW THIS DRAWING PRIOR TO CONSTRUCTION. IT IS THE ULTIMATE RESPONSIBILITY OF THE SITE DESIGN ENGINEER TO ENSURE THAT THE PRODUCT(S) DEPICTED AND ALL ASSOCIATED DETAILS MEET ALL APPLICABLE LAWS, REGULATIONS, AND PROJECT REQUIREMENTS.

SHEET  
**2 OF 5**

## ACCEPTABLE FILL MATERIALS: STORMTECH SC-310 CHAMBER SYSTEMS

MATERIAL LOCATION	DESCRIPTION	AASHTO MATERIAL CLASSIFICATIONS	COMPACTION / DENSITY REQUIREMENT
D	<b>FINAL FILL:</b> FILL MATERIAL FOR LAYER 'D' STARTS FROM THE TOP OF THE 'C' LAYER TO THE BOTTOM OF FLEXIBLE PAVEMENT OR UNPAVED FINISHED GRADE ABOVE. NOTE THAT PAVEMENT SUBBASE MAY BE PART OF THE 'D' LAYER	N/A	PREPARE PER SITE DESIGN ENGINEER'S PLANS. PAVED INSTALLATIONS MAY HAVE STRINGENT MATERIAL AND PREPARATION REQUIREMENTS.
C	<b>INITIAL FILL:</b> FILL MATERIAL FOR LAYER 'C' STARTS FROM THE TOP OF THE EMBEDMENT STONE ('B' LAYER) TO 18" (450 mm) ABOVE THE TOP OF THE CHAMBER. NOTE THAT PAVEMENT SUBBASE MAY BE A PART OF THE 'C' LAYER.	AASHTO M145 <sup>1</sup> A-1, A-2-4, A-3  OR AASHTO M43 <sup>1</sup> 3, 357, 4, 467, 5, 56, 57, 6, 67, 68, 7, 78, 8, 89, 9, 10	BEGIN COMPACTIONS AFTER 12" (300 mm) OF MATERIAL OVER THE CHAMBERS IS REACHED. COMPACT ADDITIONAL LAYERS IN 6" (150 mm) MAX LIFTS TO A MIN. 95% PROCTOR DENSITY FOR WELL GRADED MATERIAL AND 95% RELATIVE DENSITY FOR PROCESSED AGGREGATE MATERIALS. ROLLER GROSS VEHICLE WEIGHT NOT TO EXCEED 12,000 lbs (53 kN). DYNAMIC FORCE NOT TO EXCEED 20,000 lbs (89 kN).
B	<b>EMBEDMENT STONE:</b> FILL SURROUNDING THE CHAMBERS FROM THE FOUNDATION STONE ('A' LAYER) TO THE 'C' LAYER ABOVE.	AASHTO M43 <sup>1</sup> 3, 357, 4, 467, 5, 56, 57	NO COMPACTION REQUIRED.
A	<b>FOUNDATION STONE:</b> FILL BELOW CHAMBERS FROM THE SUBGRADE UP TO THE FOOT (BOTTOM) OF THE CHAMBER.	AASHTO M43 <sup>1</sup> 3, 357, 4, 467, 5, 56, 57	PLATE COMPACT OR ROLL TO ACHIEVE A FLAT SURFACE. <sup>2 3</sup>

**PLEASE NOTE:**

- THE LISTED AASHTO DESIGNATIONS ARE FOR GRADATIONS ONLY. THE STONE MUST ALSO BE CLEAN, CRUSHED, ANGULAR. FOR EXAMPLE, A SPECIFICATION FOR #4 STONE WOULD STATE: "CLEAN, CRUSHED, ANGULAR NO. 4 (AASHTO M43) STONE".
- STORMTECH COMPACTION REQUIREMENTS ARE MET FOR 'A' LOCATION MATERIALS WHEN PLACED AND COMPACTED IN 6" (150 mm) (MAX) LIFTS USING TWO FULL COVERAGES WITH A VIBRATORY COMPACTOR.
- WHERE INFILTRATION SURFACES MAY BE COMPROMISED BY COMPACTION, FOR STANDARD DESIGN LOAD CONDITIONS, A FLAT SURFACE MAY BE ACHIEVED BY RAKING OR DRAGGING WITHOUT COMPACTION EQUIPMENT. FOR SPECIAL LOAD DESIGNS, CONTACT STORMTECH FOR COMPACTION REQUIREMENTS.

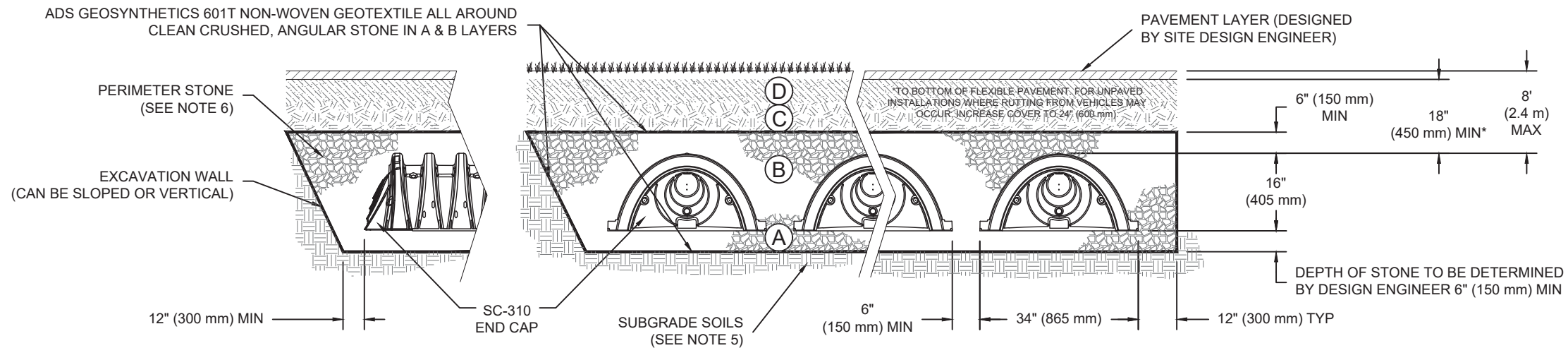

**NOTES:**

- SC-310 CHAMBERS SHALL CONFORM TO THE REQUIREMENTS OF ASTM F2418 "STANDARD SPECIFICATION FOR POLYPROPYLENE (PP) CORRUGATED WALL STORMWATER COLLECTION CHAMBERS", OR ASTM F2922 "STANDARD SPECIFICATION FOR POLYETHYLENE (PE) CORRUGATED WALL STORMWATER COLLECTION CHAMBERS".
- SC-310 CHAMBERS SHALL BE DESIGNED IN ACCORDANCE WITH ASTM F2787 "STANDARD PRACTICE FOR STRUCTURAL DESIGN OF THERMOPLASTIC CORRUGATED WALL STORMWATER COLLECTION CHAMBERS".
- "ACCEPTABLE FILL MATERIALS" TABLE ABOVE PROVIDES MATERIAL LOCATIONS, DESCRIPTIONS, GRADATIONS, AND COMPACTION REQUIREMENTS FOR FOUNDATION, EMBEDMENT, AND FILL MATERIALS.
- THE "SITE DESIGN ENGINEER" REFERS TO THE ENGINEER RESPONSIBLE FOR THE DESIGN AND LAYOUT OF THE STORMTECH CHAMBERS FOR THIS PROJECT.
- THE SITE DESIGN ENGINEER IS RESPONSIBLE FOR ASSESSING THE BEARING RESISTANCE (ALLOWABLE BEARING CAPACITY) OF THE SUBGRADE SOILS AND THE DEPTH OF FOUNDATION STONE WITH CONSIDERATION FOR THE RANGE OF EXPECTED SOIL MOISTURE CONDITIONS.
- PERIMETER STONE MUST BE EXTENDED HORIZONTALLY TO THE EXCAVATION WALL FOR BOTH VERTICAL AND SLOPED EXCAVATION WALLS.
- ONCE LAYER 'C' IS PLACED, ANY SOIL/MATERIAL CAN BE PLACED IN LAYER 'D' UP TO THE FINISHED GRADE. MOST PAVEMENT SUBBASE SOILS CAN BE USED TO REPLACE THE MATERIAL REQUIREMENTS OF LAYER 'C' OR 'D' AT THE SITE DESIGN ENGINEER'S DISCRETION.

<b>The Meadowlands (A-4)</b> Madison, WI	DATE: 01/29/2019 DRAWN: BA PROJECT #: Tool CHECKED: ---	<p style="font-size: small;">70 INWOOD ROAD, SUITE 3   ROCKY HILL   CT   06867                  860-525-8188   888-892-2694   WWW.STORMTECH.COM</p>
DESCRIPTION		
CHK		
DRW		
REV		
		SHEET <b>3 OF 5</b>

THIS DRAWING HAS BEEN PREPARED BASED ON INFORMATION PROVIDED TO ADS UNDER THE DIRECTION OF THE SITE DESIGN ENGINEER OR OTHER PROJECT REPRESENTATIVE. THE SITE DESIGN ENGINEER SHALL REVIEW THIS DRAWING PRIOR TO CONSTRUCTION. IT IS THE ULTIMATE RESPONSIBILITY OF THE SITE DESIGN ENGINEER TO ENSURE THAT THE PRODUCT(S) DEPICTED AND ALL ASSOCIATED DETAILS MEET ALL APPLICABLE LAWS, REGULATIONS, AND PROJECT REQUIREMENTS.

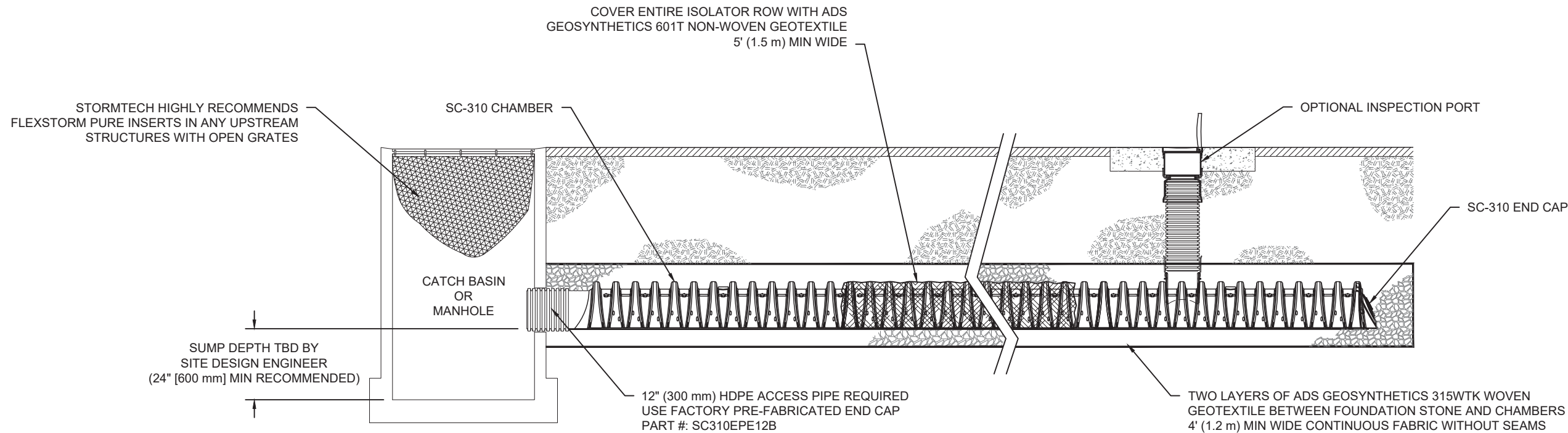

**SC-310 ISOLATOR ROW DETAIL**  
NTS

**INSPECTION & MAINTENANCE**

- STEP 1) INSPECT ISOLATOR ROW FOR SEDIMENT
- A. INSPECTION PORTS (IF PRESENT)
    - A.1. REMOVE/OPEN LID ON NYLOPLAST INLINE DRAIN
    - A.2. REMOVE AND CLEAN FLEXSTORM FILTER IF INSTALLED
    - A.3. USING A FLASHLIGHT AND STADIA ROD, MEASURE DEPTH OF SEDIMENT AND RECORD ON MAINTENANCE LOG
    - A.4. LOWER A CAMERA INTO ISOLATOR ROW FOR VISUAL INSPECTION OF SEDIMENT LEVELS (OPTIONAL)
    - A.5. IF SEDIMENT IS AT, OR ABOVE, 3" (80 mm) PROCEED TO STEP 2. IF NOT, PROCEED TO STEP 3.
  - B. ALL ISOLATOR ROWS
    - B.1. REMOVE COVER FROM STRUCTURE AT UPSTREAM END OF ISOLATOR ROW
    - B.2. USING A FLASHLIGHT, INSPECT DOWN THE ISOLATOR ROW THROUGH OUTLET PIPE
      - i) MIRRORS ON POLES OR CAMERAS MAY BE USED TO AVOID A CONFINED SPACE ENTRY
      - ii) FOLLOW OSHA REGULATIONS FOR CONFINED SPACE ENTRY IF ENTERING MANHOLE
    - B.3. IF SEDIMENT IS AT, OR ABOVE, 3" (80 mm) PROCEED TO STEP 2. IF NOT, PROCEED TO STEP 3.
- STEP 2) CLEAN OUT ISOLATOR ROW USING THE JETVAC PROCESS
- A. A FIXED CULVERT CLEANING NOZZLE WITH REAR FACING SPREAD OF 45" (1.1 m) OR MORE IS PREFERRED
  - B. APPLY MULTIPLE PASSES OF JETVAC UNTIL BACKFLUSH WATER IS CLEAN
  - C. VACUUM STRUCTURE SUMP AS REQUIRED
- STEP 3) REPLACE ALL COVERS, GRATES, FILTERS, AND LIDS; RECORD OBSERVATIONS AND ACTIONS.
- STEP 4) INSPECT AND CLEAN BASINS AND MANHOLES UPSTREAM OF THE STORMTECH SYSTEM.

**NOTES**

1. INSPECT EVERY 6 MONTHS DURING THE FIRST YEAR OF OPERATION. ADJUST THE INSPECTION INTERVAL BASED ON PREVIOUS OBSERVATIONS OF SEDIMENT ACCUMULATION AND HIGH WATER ELEVATIONS.
2. CONDUCT JETTING AND VACTORING ANNUALLY OR WHEN INSPECTION SHOWS THAT MAINTENANCE IS NECESSARY.

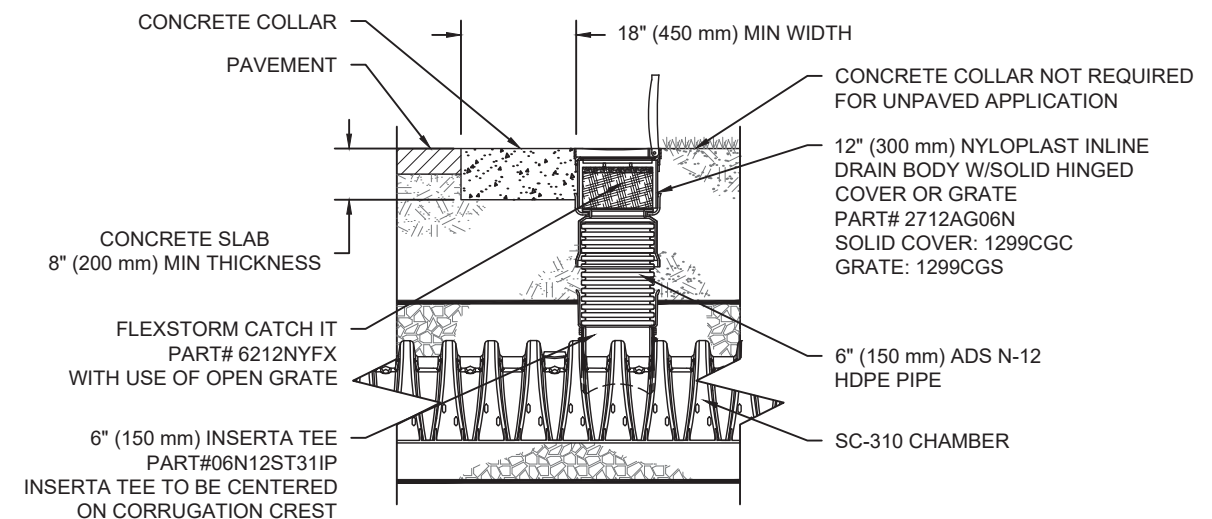

**SC-310 6" INSPECTION PORT DETAIL**  
NTS

The Meadowlands (A-4)	
Madison, WI	
DATE: 01/29/2019	DRAWN: BA
PROJECT #: Tool	CHECKED: ---

REV	DRW	CHK	DESCRIPTION

70 INWOOD ROAD, SUITE 3 | ROCKY HILL | CT | 06067  
860-525-8188 | 888-892-2694 | WWW.STORMTECH.COM

4640 TRUEMAN BLVD  
HILLIARD, OH 43026  
1-800-733-7473

THIS DRAWING HAS BEEN PREPARED BASED ON INFORMATION PROVIDED TO ADS UNDER THE DIRECTION OF THE SITE DESIGN ENGINEER OR OTHER PROJECT REPRESENTATIVE. THE SITE DESIGN ENGINEER SHALL REVIEW THIS DRAWING PRIOR TO CONSTRUCTION. IT IS THE ULTIMATE RESPONSIBILITY OF THE SITE DESIGN ENGINEER TO ENSURE THAT THE PRODUCT(S) DEPICTED AND ALL ASSOCIATED DETAILS MEET ALL APPLICABLE LAWS, REGULATIONS, AND PROJECT REQUIREMENTS.

**UNDERDRAIN DETAIL**

NTS

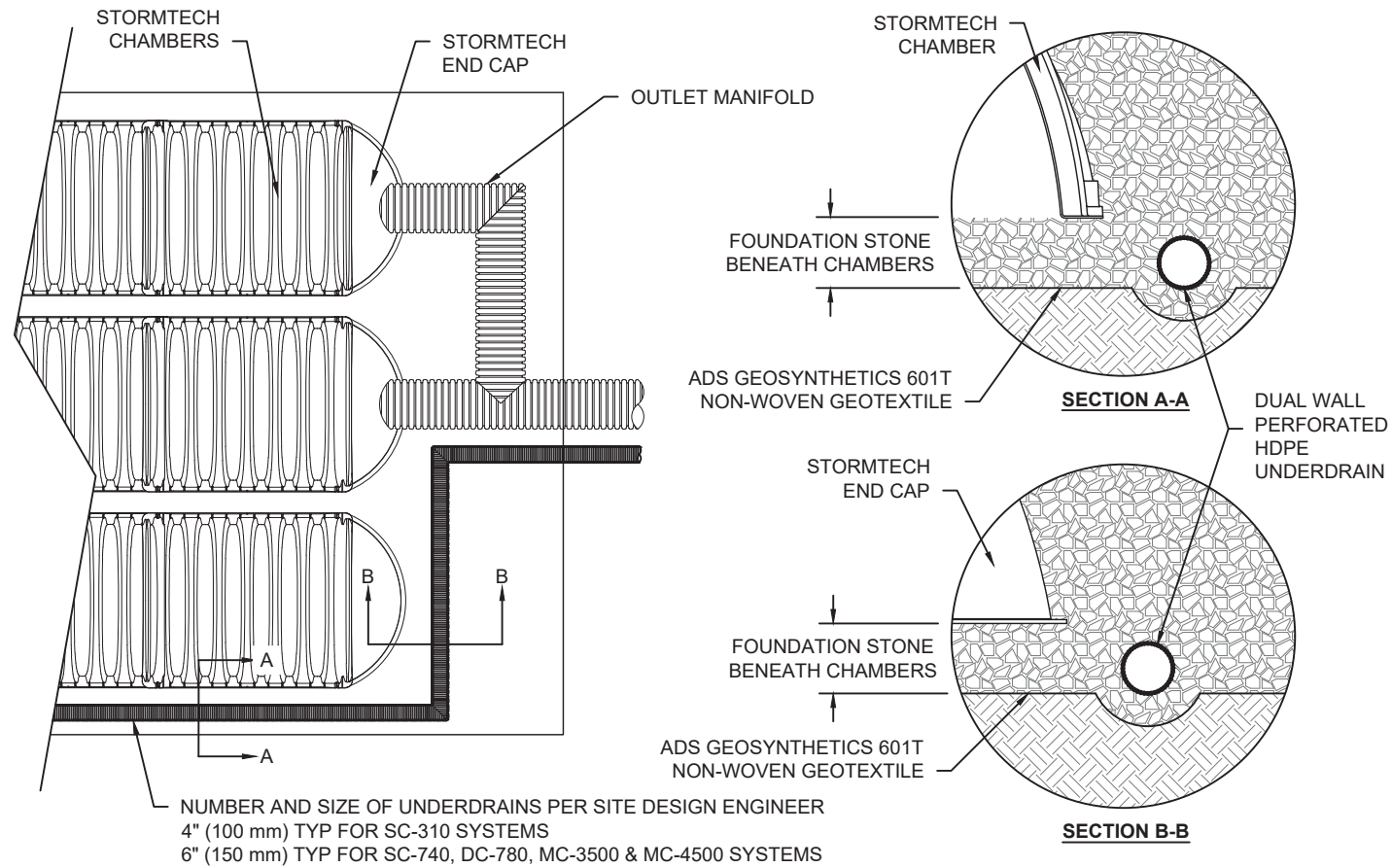

**INSERTA TEE DETAIL**

NTS

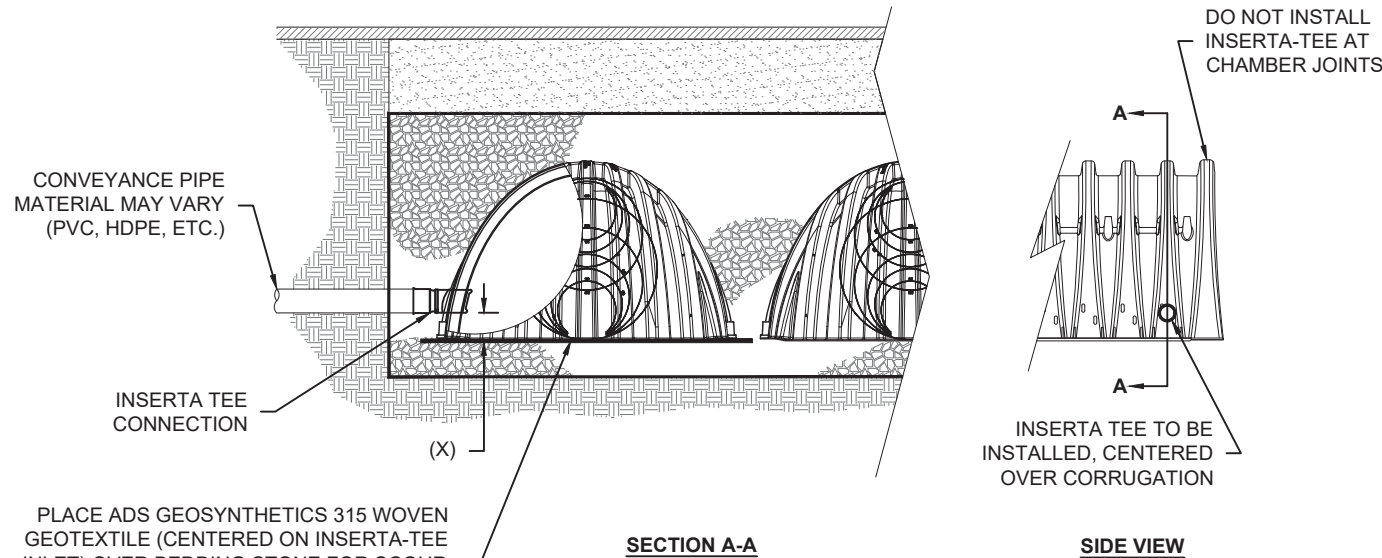

CHAMBER	MAX DIAMETER OF INSERTA TEE	HEIGHT FROM BASE OF CHAMBER (X)
SC-310	6" (150 mm)	4" (100 mm)
SC-740	10" (250 mm)	4" (100 mm)
DC-780	10" (250 mm)	4" (100 mm)
MC-3500	12" (300 mm)	6" (150 mm)
MC-4500	12" (300 mm)	8" (200 mm)

**NOTE:**  
 PART NUMBERS WILL VARY BASED ON INLET PIPE MATERIALS. CONTACT STORMTECH FOR MORE INFORMATION.

INSERTA TEE FITTINGS AVAILABLE FOR SDR 26, SDR 35, SCH 40 IPS GASKETED & SOLVENT WELD, N-12, HP STORM, C-900 OR DUCTILE IRON

**SC-310 TECHNICAL SPECIFICATION**

NTS

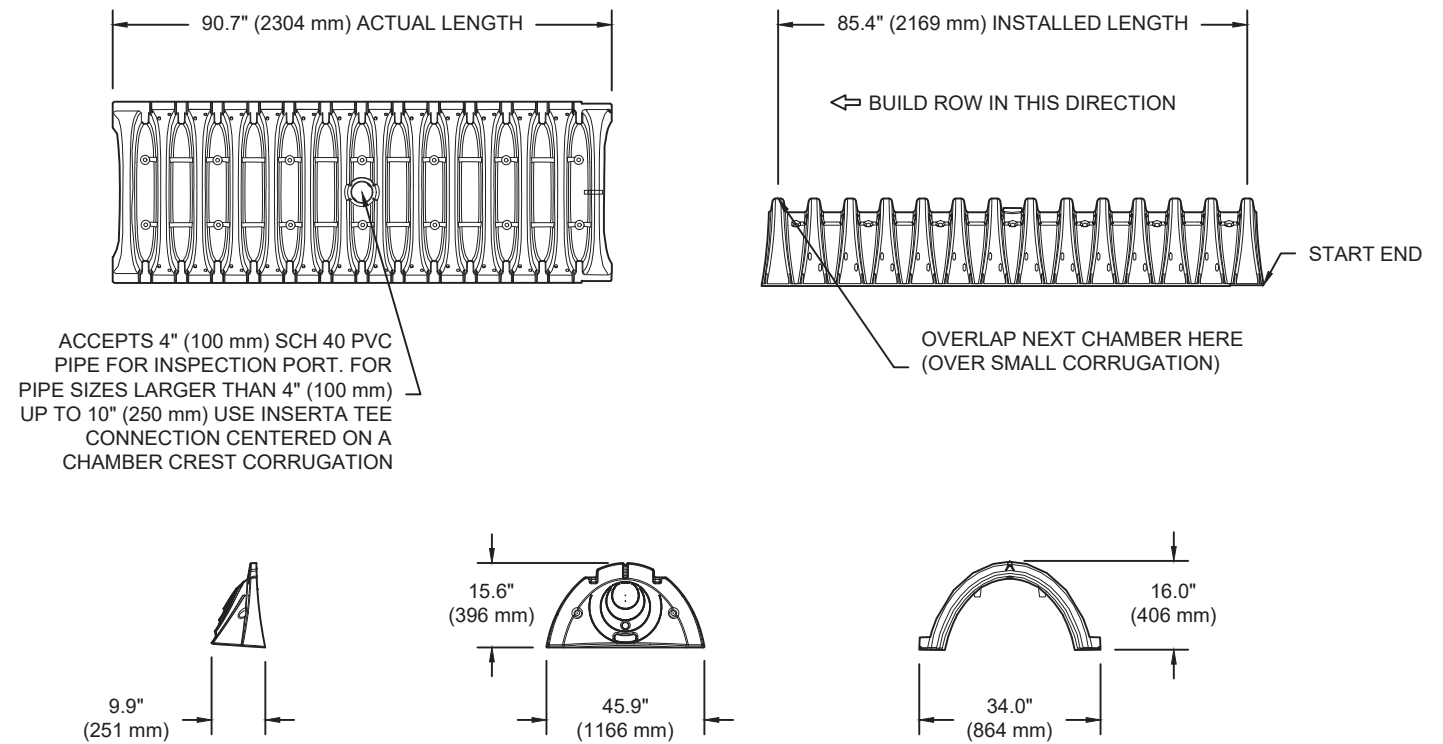

**NOMINAL CHAMBER SPECIFICATIONS**

SIZE (W X H X INSTALLED LENGTH)	34.0" X 16.0" X 85.4"	(864 mm X 406 mm X 2169 mm)
CHAMBER STORAGE	14.7 CUBIC FEET	(0.42 m <sup>3</sup> )
MINIMUM INSTALLED STORAGE*	31.0 CUBIC FEET	(0.88 m <sup>3</sup> )
WEIGHT	35.0 lbs.	(16.8 kg)

\*ASSUMES 6" (152 mm) ABOVE, BELOW, AND BETWEEN CHAMBERS

STUBS AT BOTTOM OF END CAP FOR PART NUMBERS ENDING WITH "B"  
 STUBS AT TOP OF END CAP FOR PART NUMBERS ENDING WITH "T"

PART #	STUB	A	B	C
SC310EPE06T / SC310EPE06TPC	6" (150 mm)	9.6" (244 mm)	5.8" (147 mm)	---
SC310EPE06B / SC310EPE06BPC			---	0.5" (13 mm)
SC310EPE08T / SC310EPE08TPC	8" (200 mm)	11.9" (302 mm)	3.5" (89 mm)	---
SC310EPE08B / SC310EPE08BPC			---	0.6" (15 mm)
SC310EPE10T / SC310EPE10TPC	10" (250 mm)	12.7" (323 mm)	1.4" (36 mm)	---
SC310EPE10B / SC310EPE10BPC			---	0.7" (18 mm)
SC310EPE12B	12" (300 mm)	13.5" (343 mm)	---	0.9" (23 mm)

ALL STUBS, EXCEPT FOR THE SC310EPE12B ARE PLACED AT BOTTOM OF END CAP SUCH THAT THE OUTSIDE DIAMETER OF THE STUB IS FLUSH WITH THE BOTTOM OF THE END CAP. FOR ADDITIONAL INFORMATION CONTACT STORMTECH AT 1-888-892-2694.

\* FOR THE SC310EPE12B THE 12" (300 mm) STUB LIES BELOW THE BOTTOM OF THE END CAP APPROXIMATELY 0.25" (6 mm). BACKFILL MATERIAL SHOULD BE REMOVED FROM BELOW THE N-12 STUB SO THAT THE FITTING SITS LEVEL.

NOTE: ALL DIMENSIONS ARE NOMINAL

The Meadowlands (A-4)  
 Madison, WI

DATE: 01/29/2019  
 DRAWN: BA  
 PROJECT #: Tool  
 CHECKED: ---

REV	DRW	CHK	DESCRIPTION

StormTech  
 Delivering Resilient Water Quality

70 INWOOD ROAD, SUITE 3 | ROCKY HILL | CT | 06867  
 860-525-8188 | 888-892-2694 | WWW.STORMTECH.COM

ADS  
 ADVANCED DRAINAGE SYSTEMS, INC.

4640 TRUJMAN BLVD  
 HILLIARD, OH 43026  
 1-800-733-7473

THIS DRAWING HAS BEEN PREPARED BASED ON INFORMATION PROVIDED TO ADS UNDER THE DIRECTION OF THE SITE DESIGN ENGINEER OR OTHER PROJECT REPRESENTATIVE. THE SITE DESIGN ENGINEER SHALL REVIEW THIS DRAWING PRIOR TO CONSTRUCTION. IT IS THE ULTIMATE RESPONSIBILITY OF THE SITE DESIGN ENGINEER TO ENSURE THAT THE PRODUCT(S) DEPICTED AND ALL ASSOCIATED DETAILS MEET ALL APPLICABLE LAWS, REGULATIONS, AND PROJECT REQUIREMENTS.



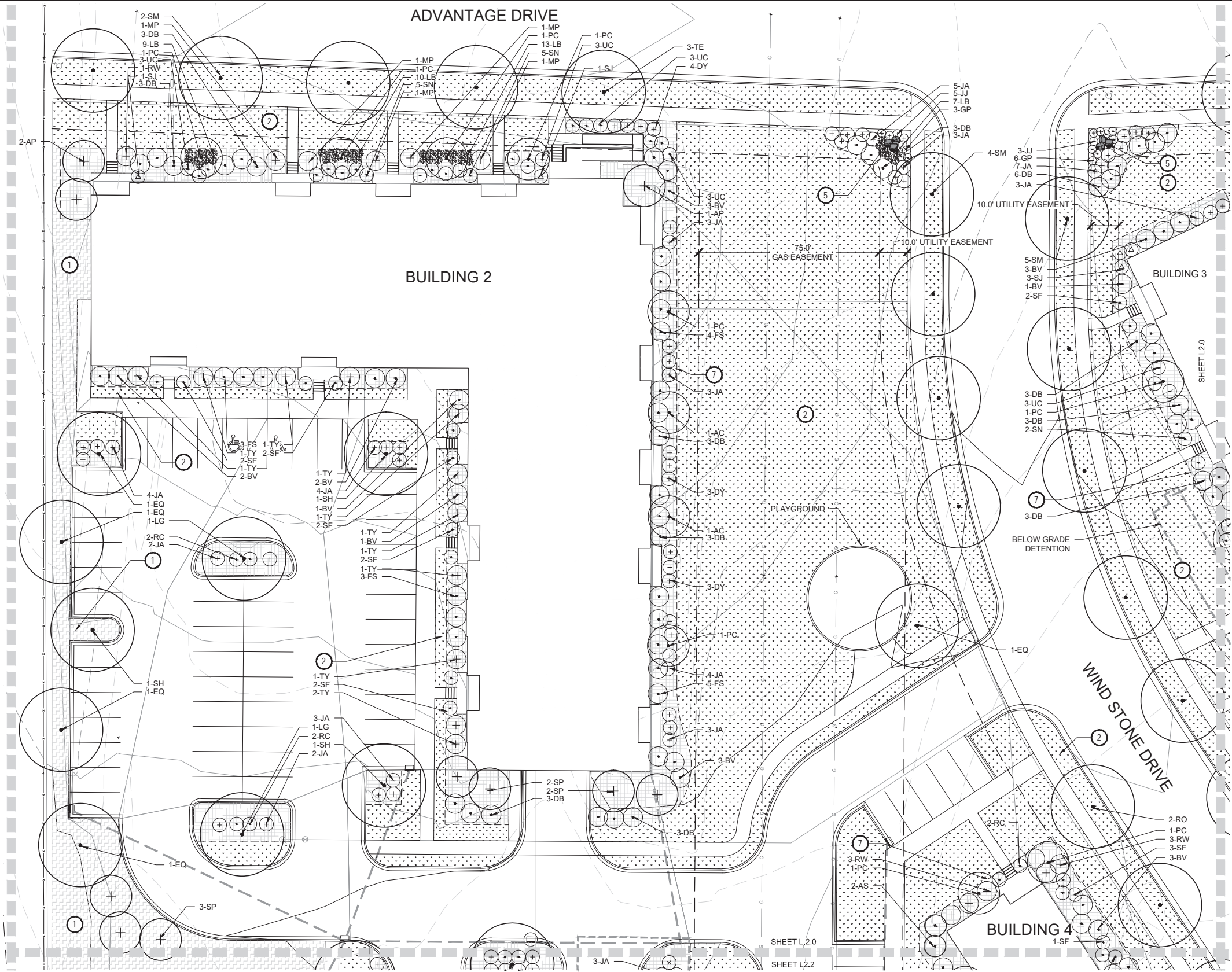

PLANTING PLAN

**PLANTING PLAN CONSTRUCTION NOTES**

- TURF SEED MIX SHALL BE VELVET GREEN TURF MIX BY HERITAGE SEED COMPANY OR APPROVED EQUAL. MIX SHALL INCLUDE 40% KENTUCKY BLUEGRASS, 40% PERENNIAL RYEGRASS, 20% FINE FESCUE.
- BLACK BEAUTY TALL FESCUE KENTUCKY BLUEGRASS (TFKB SOD) PROVIDED BY PAUL'S TURF & TREE NURSERY (608.655.3600) OR APPROVED EQUAL.
- 2'-6" COBBLE MULCH PROVIDED BY MILESTONE MATERIALS OR APPROVED EQUAL. SUBMIT SAMPLE FOR APPROVAL.
- DECOMPOSED BROWN GRANITE WITH TACKIFIER PROVIDED BY MIDWEST DECORATIVE STONE & LANDSCAPE SUPPLY (608.273.9787) OR APPROVED EQUAL.
- AQUA BLUE BOULDERS APPROXIMATELY 3' X 3' X 3' PROVIDED BY MIDWEST DECORATIVE STONE & LANDSCAPE SUPPLY (608.273.9787) OR APPROVE EQUAL. SUBMIT PHOTO SAMPLES PRIOR TO PURCHASE.
- PROVIDE 3" DEPTH SHREDDED HARDWOOD MULCH AROUND ALL STAND-ALONE TREES TO A MIN. 3-FOOT PERIMETER, AND IN ALL AREAS NOTED ON PLANS OVER GEOTEXTILE WEED CONTROL FABRIC. NO WEED CONTROL FABRIC IS REQUIRED IN GROUNDCOVER OR PERENNIAL AREAS. MULCHED LANDSCAPE BEDS SHALL HAVE A SPADED VERTICAL EDGE WHEN PERIMETER IS NOT CONCRETE CURB.
- MULCHED LANDSCAPE BEDS SHALL HAVE A SPADED VERTICAL EDGE AT 4" DEPTH WHEN PERIMETER IS NOT CONCRETE SIDEWALK OR CURB.
- REFER TO CONSTRUCTION SEQUENCE FOR NOTES REGARDING SITE RESTORATION.

**PLANT SCHEDULE**

KEY	COMMON NAME
<b>CANOPY TREES</b>	
AG	AUTUMN GOLD GINKGO
RO	NORTHERN RED OAK
SH	SKYLINE HONEYLOCUST
SM	SIENNA GLEN MAPLE
TE	TRIUMPH ELM
EQ	EMERALD QUEEN MAPLE
LG	GREENSPIRE LINDEN
<b>EVERGREEN TREES</b>	
SJ	SKYHIGH JUNIPER
AP	AUSTRIAN PINE
SP	SCOTCH PINE
<b>ORNAMENTAL TREES</b>	
PC	PRAIRIFIRE CRABAPPLE
JP	JACK FLOWERING PEAR
AC	AMUR CHOCKCHERRY
BW	WHITESPIRE BIRCH TWIN
<b>DECIDUOUS SHRUBS</b>	
2'-4' SPREAD	
GP	GOLDFINGER POTENTILLA
GS	GLOW GIRL SPIREA
AF	ARCTIC FIRE DOGWOOD
5'-7' SPREAD	
RC	ROCK COTONEASTER
SF	SHOW OFF FORSYTHIA
UC	UPRIGHT RED CHOKEBERRY
SN	SNOWMOUND SPIREA
7' + SPREAD	
AS	AUTUMN BRILLIANCE SERVICEBERRY
DB	DWARF-WINGED BURNING BUSH
FS	FRAGRANT SUMAC
BV	BLACKHAW VIBURNUM
<b>EVERGREEN SHRUBS</b>	
2'-4' SPREAD	
JJ	DWARF JAPANESE GARDEN JUNIPER
5'-7' SPREAD	
JA	ANDORRA JUNIPER
DY	DWARF YEW (BREVIFOLIA)
7' + SPREAD	
MP	DWARF MUGO PINE
RW	WHITE CATAWBA RHODODENDRON
TY	TAUNTON YEW
<b>ORNAMENTAL GRASSES</b>	
BA	BLONDE AMBITION BLUE GRAMA GRASS
SS	SHENANDOAH SWITCH GRASS
PD	PRAIRIE DROPSEED
BB	BIG BLUESTEM
LB	LITTLE BLUESTEM

**LANDSCAPE LEGEND**

- SOD, REFER TO CONSTRUCTION NOTES FOR TYPE
- SHRUB BED WITH HARDWOOD MULCH, REFER TO CONSTRUCTION NOTES FOR TYPE
- TURF SEED, REFER TO CONSTRUCTION NOTES FOR TYPE
- DECOMPOSED GRANITE, REFER TO CONSTRUCTION NOTES FOR TYPE
- COBBLE, REFER TO CONSTRUCTION NOTES FOR TYPE
- SPADE CUT EDGER AT 4" DEPTH
- DECIDUOUS CANOPY TREE
- LARGE DECIDUOUS ORNAMENTAL TREE
- EVERGREEN
- DECIDUOUS SHRUBS
- EVERGREEN SHRUBS
- UPRIGHT EVERGREEN
- ORNAMENTAL GRASSES
- LANDSCAPE BOULDERS

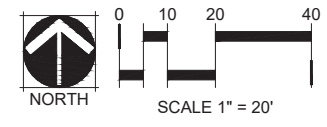

MARK	REVISION	DATE	BY

Checked By: MLC  
Scale: 1" = 20'  
Date: 01-07-2019  
Field Bk: Pg: 118.1129.30

THE MEADOWLANDS - PHASE 11  
 LANDSCAPE PLAN  
 MADISON, WI  
 5010 VOEGES ROAD  
 MADISON, WISCONSIN 53718  
**SNYDER & ASSOCIATES, INC.**  
 608-838-0444 | www.snyder-associates.com

TO OBTAIN LOCATION OF PARTICIPANTS' UNDERGROUND FACILITIES BEFORE YOU DIG IN WISCONSIN  
**CALL DIGGERS HOTLINE**  
 1-800-242-8511  
 TOLL FREE  
WS. STATUTE 182.0175 (1974)  
 REQUIRES MIN. OF 3 WORK DAYS  
 NOTICE BEFORE YOU EXCAVATE

**SNYDER & ASSOCIATES**  
 118.1129.30  
**L2.0**

ADVANTAGE DRIVE

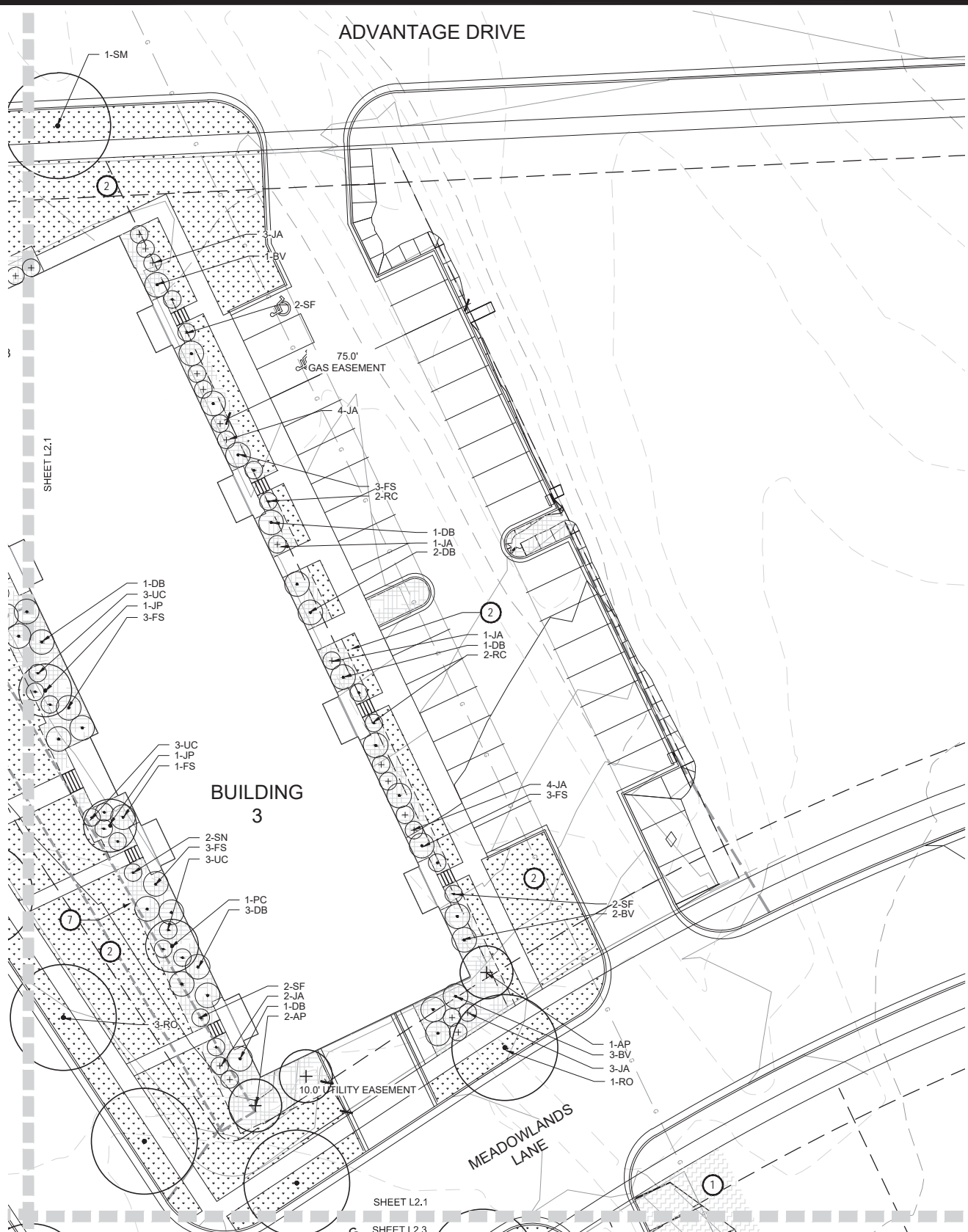

PLANTING PLAN

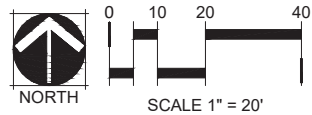

PLANTING PLAN CONSTRUCTION NOTES

- TURF SEED MIX SHALL BE VELVET GREEN TURF MIX BY HERITAGE SEED COMPANY OR APPROVED EQUAL. MIX SHALL INCLUDE 40% KENTUCKY BLUEGRASS, 40% PERENNIAL RYEGRASS, 20% FINE FESCUE.
- BLACK BEAUTY TALL FESCUE KENTUCKY BLUEGRASS (TFKB SOD) PROVIDED BY PAUL'S TURF & TREE NURSERY (608.655.3600) OR APPROVED EQUAL.
- 2-6" COBBLE MULCH PROVIDED BY MILESTONE MATERIALS OR APPROVED EQUAL. SUBMIT SAMPLE FOR APPROVAL.
- DECOMPOSED BROWN GRANITE WITH TACKIFIER PROVIDED BY MIDWEST DECORATIVE STONE & LANDSCAPE SUPPLY (608.273.9787) OR APPROVED EQUAL.
- AQUA BLUE BOULDERS APPROXIMATELY 3' X 3' X 3' PROVIDED BY MIDWEST DECORATIVE STONE & LANDSCAPE SUPPLY (608.273.9787) OR APPROVE EQUAL. SUBMIT PHOTO SAMPLES PRIOR TO PURCHASE.
- PROVIDE 3" DEPTH SHREDDED HARDWOOD MULCH AROUND ALL STAND-ALONE TREES TO A MIN. 3-FOOT PERIMETER, AND IN ALL AREAS NOTED ON PLANS OVER GEOTEXTILE WEED CONTROL FABRIC. NO WEED CONTROL FABRIC IS REQUIRED IN GROUNDCOVER OR PERENNIAL AREAS. MULCHED LANDSCAPE BEDS SHALL HAVE A SPADED VERTICAL EDGE WHEN PERIMETER IS NOT CONCRETE CURB.
- MULCHED LANDSCAPE BEDS SHALL HAVE A SPADED VERTICAL EDGE AT 4" DEPTH WHEN PERIMETER IS NOT CONCRETE SIDEWALK OR CURB.
- REFER TO CONSTRUCTION SEQUENCE FOR NOTES REGARDING SITE RESTORATION.

PLANT SCHEDULE

KEY	COMMON NAME
<b>CANOPY TREES</b>	
AG	AUTUMN GOLD GINKGO
RO	NORTHERN RED OAK
SH	SKYLINE HONEYLOCUST
SM	SIENNA GLEN MAPLE
TE	TRIUMPH ELM
EQ	EMERALD QUEEN MAPLE
LG	GREENSPIRE LINDEN
<b>EVERGREEN TREES</b>	
SJ	SKYHIGH JUNIPER
AP	AUSTRIAN PINE
SP	SCOTCH PINE
<b>ORNAMENTAL TREES</b>	
PC	PRAIRIFIRE CRABAPPLE
JP	JACK FLOWERING PEAR
AC	AMUR CHOCKCHERRY
BW	WHITESPIRE BIRCH TWIN
<b>DECIDUOUS SHRUBS</b>	
<b>2'-4" SPREAD</b>	
GP	GOLDFINGER POTENTILLA
GS	GLOW GIRL SPIREA
AF	ARCTIC FIRE DOGWOOD
<b>5'-7" SPREAD</b>	
RC	ROCK COTONEASTER
SF	SHOW OFF FORSYTHIA
UC	UPRIGHT RED CHOKEBERRY
SN	SNOWMOUND SPIREA
<b>7' + SPREAD</b>	
AS	AUTUMN BRILLIANCE SERVICEBERRY
DB	DWARF-WINGED BURNING BUSH
FS	FRAGRANT SUMAC
BV	BLACKHAW VIBURNUM
<b>EVERGREEN SHRUBS</b>	
<b>2'-4" SPREAD</b>	
JJ	DWARF JAPANESE GARDEN JUNIPER
<b>5'-7" SPREAD</b>	
JA	ANDORRA JUNIPER
DY	DWARF YEW (BREVIFOLIA)
<b>7' + SPREAD</b>	
MP	DWARF MUGO PINE
RW	WHITE CATAWBA RHODODENDRON
TY	TAUNTON YEW
<b>ORNAMENTAL GRASSES</b>	
BA	BLONDE AMBITION BLUE GRAMA GRASS
SS	SHENANDOAH SWITCH GRASS
PD	PRAIRIE DROPSEED
BB	BIG BLUESTEM
LB	LITTLE BLUESTEM

LANDSCAPE LEGEND

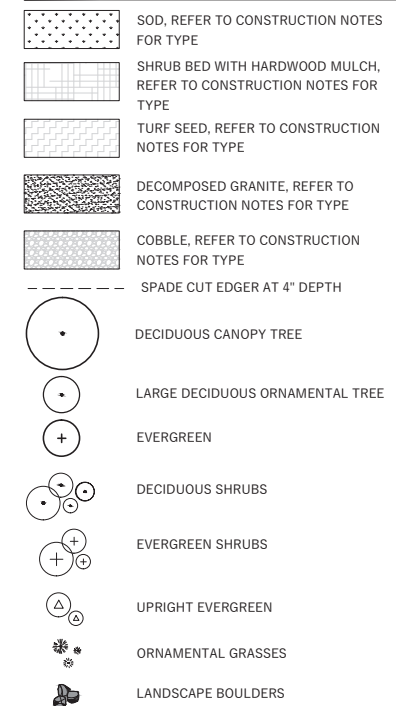

MARK	REVISION	DATE	BY

Checked By: MLC  
Date: 01-07-2019  
Scale: T = NOTED  
Field Bk: Pg: 118.1129.30

THE MEADOWLANDS - PHASE 11  
LANDSCAPE PLAN  
MADISON, WI  
5010 VOGES ROAD  
MADISON, WISCONSIN 53718  
608-838-0444 | www.snyder-associates.com  
**SNYDER & ASSOCIATES, INC.**

TO OBTAIN LOCATION OF PARTICIPANTS' UNDERGROUND FACILITIES BEFORE YOU DIG IN WISCONSIN  
CALL DIGGERS HOTLINE  
1-800-242-8511  
TOLL FREE  
WS. STATUTE 182.0175 (1974)  
REQUIRES MIN. OF 3 WORK DAYS NOTICE BEFORE YOU EXCAVATE

**SNYDER & ASSOCIATES**  
118.1129.30  
L2.1

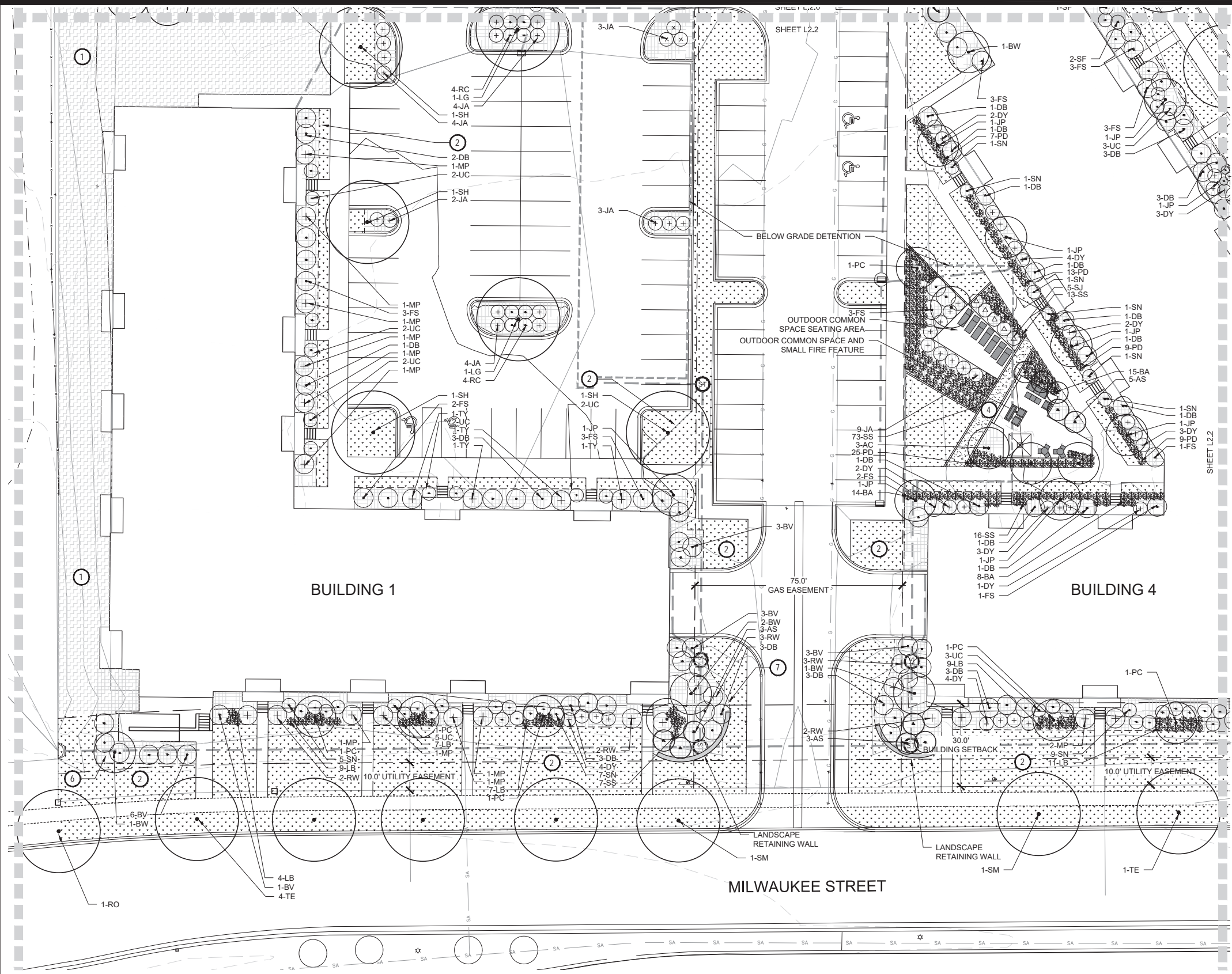

**PLANTING PLAN CONSTRUCTION NOTES**

- TURF SEED MIX SHALL BE VELVET GREEN TURF MIX BY HERITAGE SEED COMPANY OR APPROVED EQUAL. MIX SHALL INCLUDE 40% KENTUCKY BLUEGRASS, 40% PERENNIAL RYEGRASS, 20% FINE FESCUE.
- BLACK BEAUTY TALL FESCUE KENTUCKY BLUEGRASS (TFKB SOD) PROVIDED BY PAUL'S TURF & TREE NURSERY (608.655.3600) OR APPROVED EQUAL.
- 2-6" COBBLE MULCH PROVIDED BY MILESTONE MATERIALS OR APPROVED EQUAL. SUBMIT SAMPLE FOR APPROVAL.
- DECOMPOSED BROWN GRANITE WITH TACKIFIER PROVIDED BY MIDWEST DECORATIVE STONE & LANDSCAPE SUPPLY (608.273.9787) OR APPROVED EQUAL.
- AQUA BLUE BOULDERS APPROXIMATELY 3' X 3' X 3' PROVIDED BY MIDWEST DECORATIVE STONE & LANDSCAPE SUPPLY (608.273.9787) OR APPROVE EQUAL. SUBMIT PHOTO SAMPLES PRIOR TO PURCHASE.
- PROVIDE 3" DEPTH SHREDDED HARDWOOD MULCH AROUND ALL STAND-ALONE TREES TO A MIN. 3-FOOT PERIMETER, AND IN ALL AREAS NOTED ON PLANS OVER GEOTEXTILE WEED CONTROL FABRIC. NO WEED CONTROL FABRIC IS REQUIRED IN GROUNDCOVER OR PERENNIAL AREAS. MULCHED LANDSCAPE BEDS SHALL HAVE A SPADED VERTICAL EDGE WHEN PERIMETER IS NOT CONCRETE CURB.
- MULCHED LANDSCAPE BEDS SHALL HAVE A SPADED VERTICAL EDGE AT 4" DEPTH WHEN PERIMETER IS NOT CONCRETE SIDEWALK OR CURB.
- REFER TO CONSTRUCTION SEQUENCE FOR NOTES REGARDING SITE RESTORATION.

**PLANT SCHEDULE**

KEY	COMMON NAME
<b>CANOPY TREES</b>	
AG	AUTUMN GOLD GINKGO
RO	NORTHERN RED OAK
SH	SKYLINE HONEYLOCUST
SM	SIENNA GLEN MAPLE
TE	TRIUMPH ELM
EQ	EMERALD QUEEN MAPLE
LG	GREENSPIRE LINDEN
<b>EVERGREEN TREES</b>	
SJ	SKYHIGH JUNIPER
AP	AUSTRIAN PINE
SP	SCOTCH PINE
<b>ORNAMENTAL TREES</b>	
PC	PRAIRIFIRE CRABAPPLE
JP	JACK FLOWERING PEAR
AC	AMUR CHOCKCHERRY
BW	WHITESPIRE BIRCH TWIN
<b>DECIDUOUS SHRUBS</b>	
<b>2'-4" SPREAD</b>	
GP	GOLDFINGER POTENTILLA
GS	GLOW GIRL SPIREA
AF	ARCTIC FIRE DOGWOOD
<b>5'-7" SPREAD</b>	
RC	ROCK COTONEASTER
SF	SHOW OFF FORSYTHIA
UC	UPRIGHT RED CHOKEBERRY
SN	SNOWMOUND SPIREA
<b>7'+ SPREAD</b>	
AS	AUTUMN BRILLIANCE SERVICEBERRY
DB	DWARF-WINGED BURNING BUSH
FS	FRAGRANT SUMAC
BV	BLACKHAW VIBURNUM
<b>EVERGREEN SHRUBS</b>	
<b>2'-4" SPREAD</b>	
JJ	DWARF JAPANESE GARDEN JUNIPER
<b>5'-7" SPREAD</b>	
JA	ANDORRA JUNIPER
DY	DWARF YEW (BREVIFOLIA)
<b>7'+ SPREAD</b>	
MP	DWARF MUGO PINE
RW	WHITE CATAWBA RHODODENDRON
TY	TAUNTON YEW
<b>ORNAMENTAL GRASSES</b>	
BA	BLONDE AMBITION BLUE GRAMA GRASS
SS	SHENANDOAH SWITCH GRASS
PD	PRAIRIE DROPSEED
BB	BIG BLUESTEM
LB	LITTLE BLUESTEM

**LANDSCAPE LEGEND**

- SOD, REFER TO CONSTRUCTION NOTES FOR TYPE
- SHRUB BED WITH HARDWOOD MULCH, REFER TO CONSTRUCTION NOTES FOR TYPE
- TURF SEED, REFER TO CONSTRUCTION NOTES FOR TYPE
- DECOMPOSED GRANITE, REFER TO CONSTRUCTION NOTES FOR TYPE
- COBBLE, REFER TO CONSTRUCTION NOTES FOR TYPE
- SPADE CUT EDGER AT 4" DEPTH
- DECIDUOUS CANOPY TREE
- LARGE DECIDUOUS ORNAMENTAL TREE
- EVERGREEN
- DECIDUOUS SHRUBS
- EVERGREEN SHRUBS
- UPRIGHT EVERGREEN
- ORNAMENTAL GRASSES
- LANDSCAPE BOULDERS

PLANTING PLAN

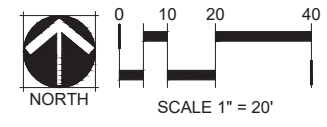

MARK	REVISION	DATE	BY

Checked By: MLC  
Date: 01-07-2019  
Field Bk: Pg: 118.1129.30

THE MEADOWLANDS - PHASE 11  
 LANDSCAPE PLAN  
 MADISON, WI  
 5010 VOEGES ROAD  
 MADISON, WISCONSIN 53718  
 608-838-0444 | www.snyder-associates.com  
**SNYDER & ASSOCIATES, INC.**

TO OBTAIN LOCATION OF PARTICIPANTS' UNDERGROUND FACILITIES BEFORE YOU DIG IN WISCONSIN  
**CALL DIGGERS HOTLINE**  
**1-800-242-8511**  
**TOLL FREE**  
WS. STATUTE 182.0175 (1974)  
 REQUIRES MIN. OF 3 WORK DAYS  
 NOTICE BEFORE YOU EXCAVATE

**SNYDER & ASSOCIATES**  
 118.1129.30  
**L2.2**



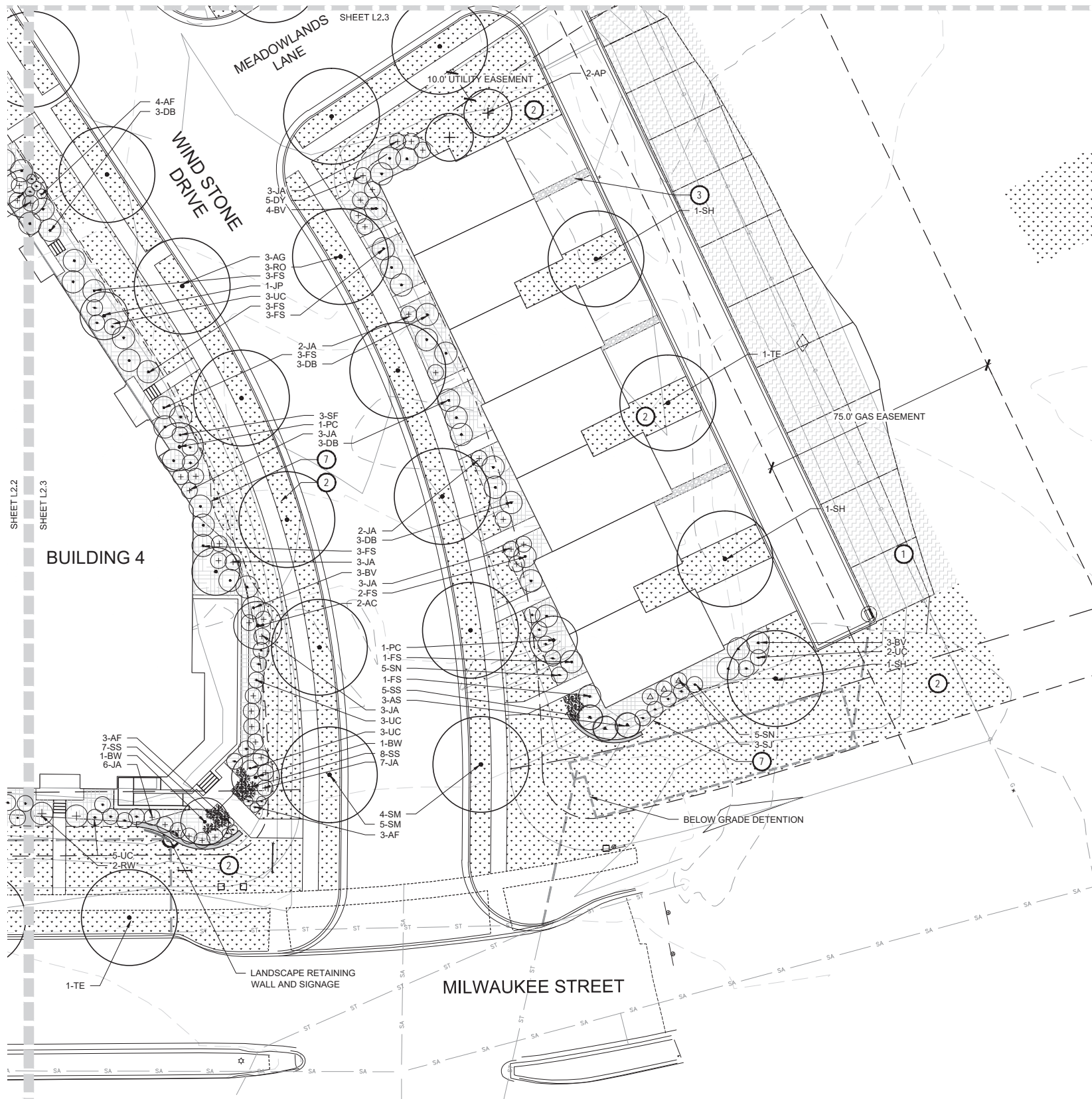

PLANTING PLAN

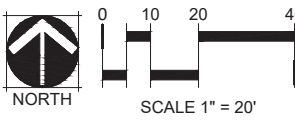

**PLANTING PLAN CONSTRUCTION NOTES**

- TURF SEED MIX SHALL BE VELVET GREEN TURF MIX BY HERITAGE SEED COMPANY OR APPROVED EQUAL. MIX SHALL INCLUDE 40% KENTUCKY BLUEGRASS, 40% PERENNIAL RYEGRASS, 20% FINE FESCUE.
- BLACK BEAUTY TALL FESCUE KENTUCKY BLUEGRASS (TFKB SOD) PROVIDED BY PAUL'S TURF & TREE NURSERY (608.655.3600) OR APPROVED EQUAL.
- 2-6" COBBLE MULCH PROVIDED BY MILESTONE MATERIALS OR APPROVED EQUAL. SUBMIT SAMPLE FOR APPROVAL.
- DECOMPOSED BROWN GRANITE WITH TACKIFIER PROVIDED BY MIDWEST DECORATIVE STONE & LANDSCAPE SUPPLY (608.273.9787) OR APPROVED EQUAL.
- AQUA BLUE BOULDERS APPROXIMATELY 3' X 3' X 3' PROVIDED BY MIDWEST DECORATIVE STONE & LANDSCAPE SUPPLY (608.273.9787) OR APPROVE EQUAL. SUBMIT PHOTO SAMPLES PRIOR TO PURCHASE.
- PROVIDE 3" DEPTH SHREDDED HARDWOOD MULCH AROUND ALL STAND-ALONE TREES TO A MIN. 3-FOOT PERIMETER, AND IN ALL AREAS NOTED ON PLANS OVER GEOTEXTILE WEED CONTROL FABRIC. NO WEED CONTROL FABRIC IS REQUIRED IN GROUND COVER OR PERENNIAL AREAS. MULCHED LANDSCAPE BEDS SHALL HAVE A SPADED VERTICAL EDGE WHEN PERIMETER IS NOT CONCRETE CURB.
- MULCHED LANDSCAPE BEDS SHALL HAVE A SPADED VERTICAL EDGE AT 4" DEPTH WHEN PERIMETER IS NOT CONCRETE SIDEWALK OR CURB.
- REFER TO CONSTRUCTION SEQUENCE FOR NOTES REGARDING SITE RESTORATION.

**PLANT SCHEDULE**

KEY	COMMON NAME
<b>CANOPY TREES</b>	
AG	AUTUMN GOLD GINKGO
RO	NORTHERN RED OAK
SH	SKYLINE HONEYLOCUST
SM	SIENNA GLEN MAPLE
TE	TRIUMPH ELM
EQ	EMERALD QUEEN MAPLE
LG	GREENSPIRE LINDEN
<b>EVERGREEN TREES</b>	
SJ	SKYHIGH JUNIPER
AP	AUSTRIAN PINE
SP	SCOTCH PINE
<b>ORNAMENTAL TREES</b>	
PC	PRAIRIFIRE CRABAPPLE
JP	JACK FLOWERING PEAR
AC	AMUR CHOCKCHERRY
BW	WHITESPIRE BIRCH TWIN
<b>DECIDUOUS SHRUBS</b>	
<b>2'-4' SPREAD</b>	
GP	GOLDFINGER POTENTILLA
GS	GLOW GIRL SPIREA
AF	ARCTIC FIRE DOGWOOD
<b>5'-7' SPREAD</b>	
RC	ROCK COTONEASTER
SF	SHOW OFF FORSYTHIA
UC	UPRIGHT RED CHOKEBERRY
SN	SNOWMOUND SPIREA
<b>7' + SPREAD</b>	
AS	AUTUMN BRILLIANCE SERVICEBERRY
DB	DWARF-WINGED BURNING BUSH
FS	FRAGRANT SUMAC
BV	BLACKHAW VIBURNUM
<b>EVERGREEN SHRUBS</b>	
<b>2'-4' SPREAD</b>	
JJ	DWARF JAPANESE GARDEN JUNIPER
<b>5'-7' SPREAD</b>	
JA	ANDORRA JUNIPER
DY	DWARF YEWE (BREVIFOLIA)
<b>7' + SPREAD</b>	
MP	DWARF MUGO PINE
RW	WHITE CATAWBA RHODODENDRON
TY	TAUNTON YEWE
<b>ORNAMENTAL GRASSES</b>	
BA	BLONDE AMBITION BLUE GRAMA GRASS
SS	SHENANDOAH SWITCH GRASS
PD	PRAIRIE DROPSEED
BB	BIG BLUESTEM
LB	LITTLE BLUESTEM

**LANDSCAPE LEGEND**

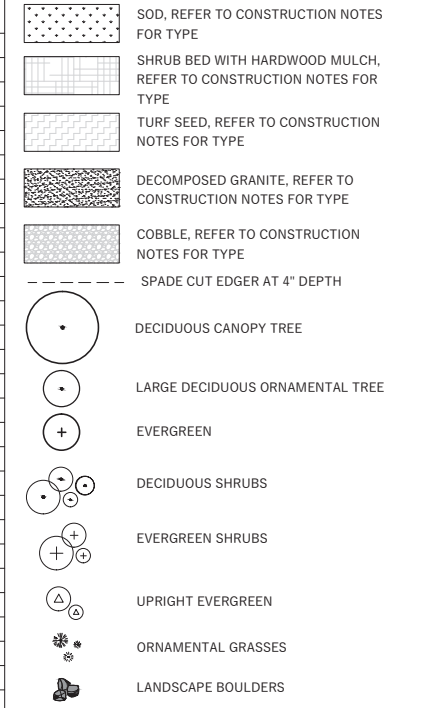

MARK	REVISION	DATE	BY

Checked By: MLC  
Date: 01-07-2019  
Scale: T = NOTED  
Field Bk: Pg: 118.1129.30

THE MEADOWLANDS - PHASE 11  
LANDSCAPE PLAN

**MADISON, WI**

**SNYDER & ASSOCIATES, INC.**

5010 VOGES ROAD  
MADISON, WISCONSIN 53718  
608-838-0444 | www.snyder-associates.com

TO OBTAIN LOCATION OF PARTICIPANTS' UNDERGROUND FACILITIES BEFORE YOU DIG IN WISCONSIN

**CALL DIGGERS HOTLINE**  
1-800-242-8511  
TOLL FREE

WS. STATUTE 182.0175 (1974)  
REQUIRES MIN. OF 3 WORK DAYS  
NOTICE BEFORE YOU EXCAVATE

**SNYDER & ASSOCIATES**

118.1129.30  
**L2.3**

① WRAP TRUNK FROM GROUND LINE TO FIRST BRANCH

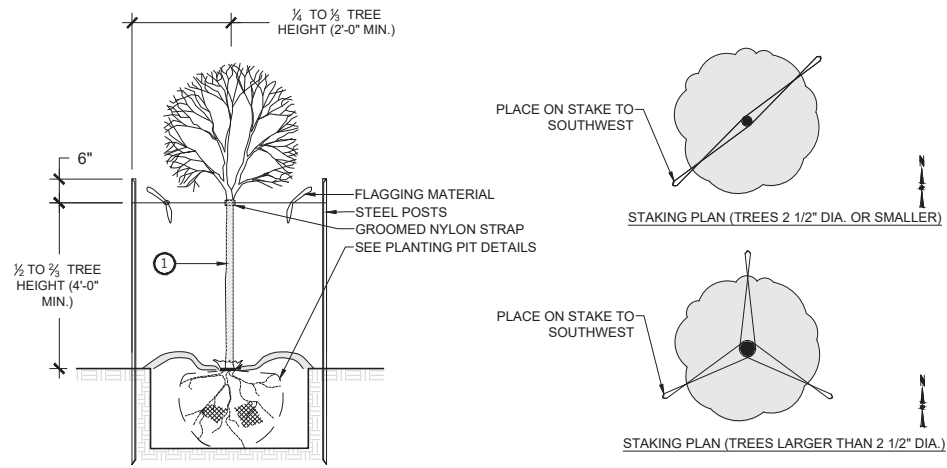

1 DECIDUOUS TREE STAKING

NO SCALE

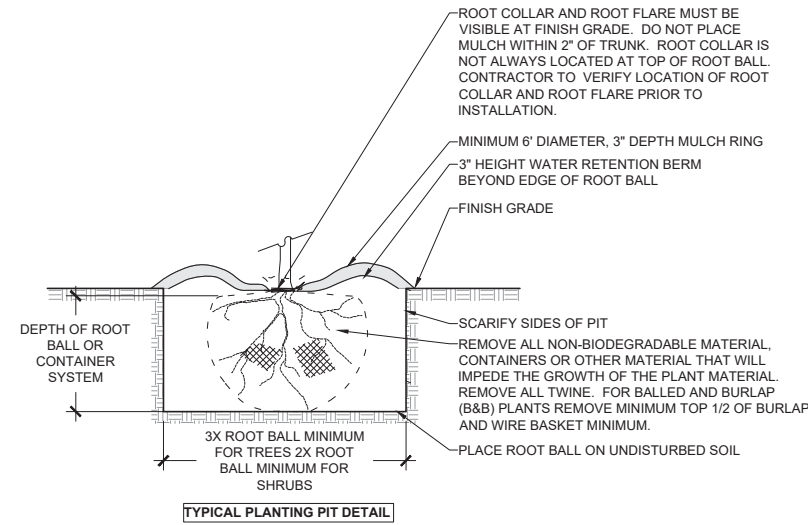

2 PLANTING PIT DETAILS

NO SCALE

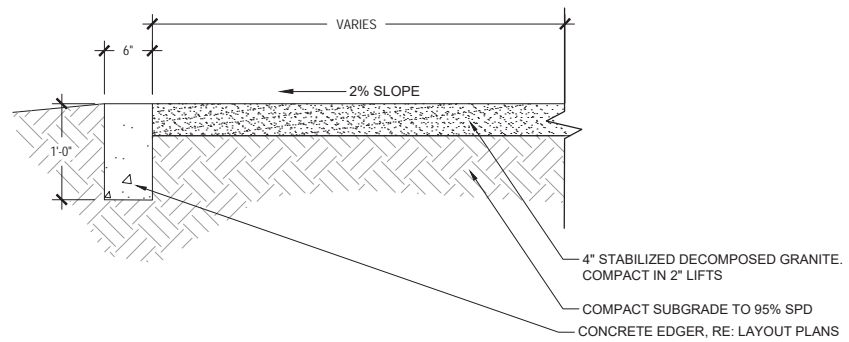
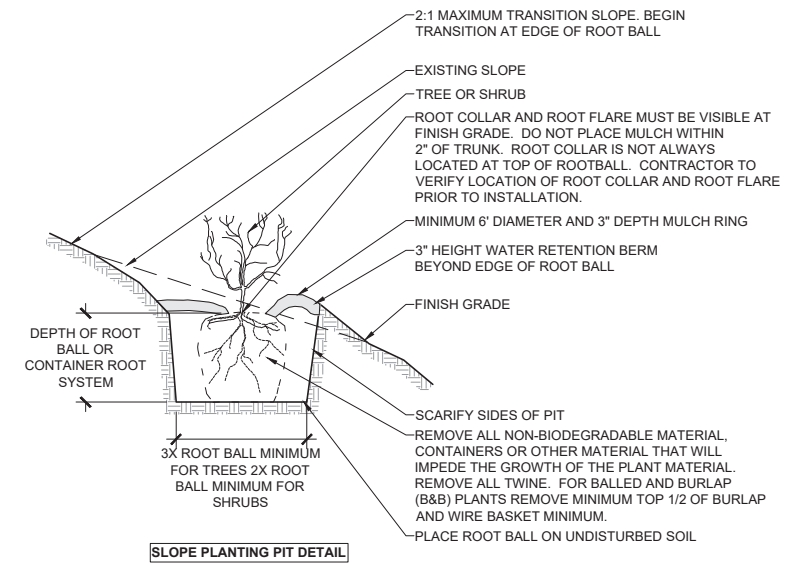

3 DECOMPOSED GRANITE

SCALE: 1" = 1'-0"

- NOTES:
1. COMPACT WET.
  2. USE A SMALL (4') RIDING ROLLER TO COMPACT CRUSHER FINES.
  3. SLOPE AT 1-2% WITH GRADE WHERE TOPOGRAPHY DICTATES.

MARK	REVISION	DATE	BY

Checked By: MLC  
Date: 01-07-2019  
Engineer: BCA  
Technician: BCA  
Scale: 1" = NOTED  
Field Bk: Pg: 118.1129.30

THE MEADOWLANDS - PHASE 11  
LANDSCAPE DETAILS

MADISON, WI

5010 VOGES ROAD  
MADISON, WISCONSIN 53718  
608-838-0444 | www.snyder-associates.com

**SNYDER & ASSOCIATES, INC.**

TO OBTAIN LOCATION OF PARTICIPANTS' UNDERGROUND FACILITIES BEFORE YOU DIG IN WISCONSIN

CALL DIGGERS HOTLINE  
1-800-242-8511  
TOLL FREE

WS. STATUTE 182.0175 (1974)  
REQUIRES MIN. OF 3 WORK DAYS  
NOTICE BEFORE YOU EXCAVATE

**SNYDER & ASSOCIATES**

118.1129.30  
L3.0

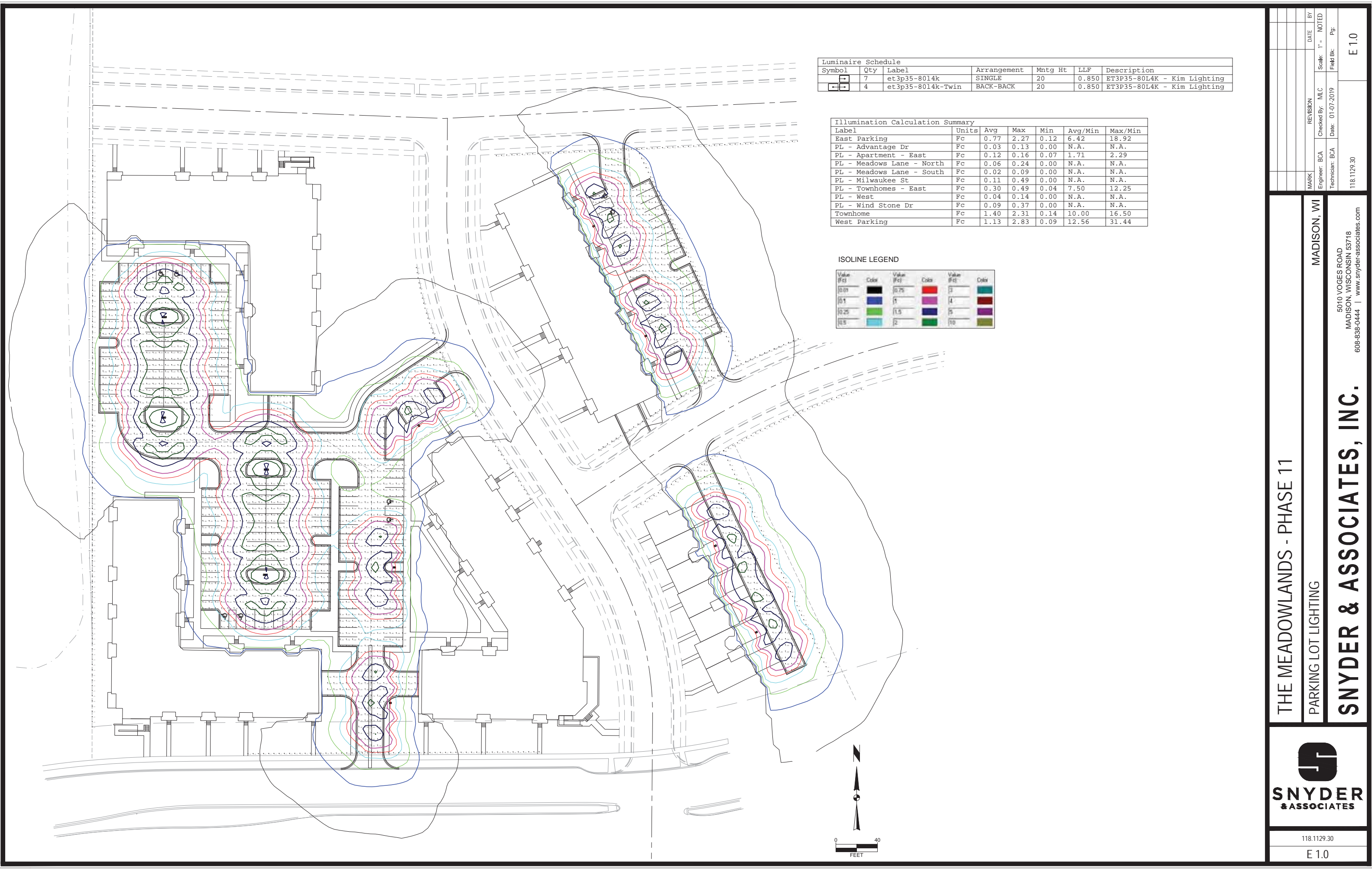

Luminaire Schedule						
Symbol	Qty	Label	Arrangement	Mntg Ht	LLF	Description
⊞	7	et3p35-80l4k	SINGLE	20	0.850	ET3P35-80L4K - Kim Lighting
⊞⊞	4	et3p35-80l4k-Twin	BACK-BACK	20	0.850	ET3P35-80L4K - Kim Lighting

Illumination Calculation Summary						
Label	Units	Avg	Max	Min	Avg/Min	Max/Min
East Parking	Fc	0.77	2.27	0.12	6.42	18.92
PL - Advantage Dr	Fc	0.03	0.13	0.00	N.A.	N.A.
PL - Apartment - East	Fc	0.12	0.16	0.07	1.71	2.29
PL - Meadows Lane - North	Fc	0.06	0.24	0.00	N.A.	N.A.
PL - Meadows Lane - South	Fc	0.02	0.09	0.00	N.A.	N.A.
PL - Milwaukee St	Fc	0.11	0.49	0.00	N.A.	N.A.
PL - Townhomes - East	Fc	0.30	0.49	0.04	7.50	12.25
PL - West	Fc	0.04	0.14	0.00	N.A.	N.A.
PL - Wind Stone Dr	Fc	0.09	0.37	0.00	N.A.	N.A.
Townhome	Fc	1.40	2.31	0.14	10.00	16.50
West Parking	Fc	1.13	2.83	0.09	12.56	31.44

ISOLINE LEGEND					
Value (fc)	Color	Value (fc)	Color	Value (fc)	Color
0.01	Black	0.75	Red	3	Teal
0.1	Blue	1	Purple	4	Dark Red
0.25	Green	1.5	Dark Blue	5	Purple
0.5	Cyan	2	Green	10	Olive

**THE MEADOWLANDS - PHASE 11**

PARKING LOT LIGHTING

**SNYDER & ASSOCIATES, INC.**

5010 VOGES ROAD  
MADISON, WISCONSIN 53718  
608-838-0444 | www.snyder-associates.com

**MADISON, WI**



**SNYDER & ASSOCIATES**

118.1129.30

E 1.0

MARK: \_\_\_\_\_

Engineer: BCA

Technician: BCA

REVISION: \_\_\_\_\_

Checked By: MLC

Date: 01-07-2019

BY: \_\_\_\_\_

DATE: \_\_\_\_\_

Scale: 1" = \_\_\_\_\_

Field Bk: \_\_\_\_\_

Pg: \_\_\_\_\_

E 1.0



# City of Madison Fire Department

314 W Dayton Street, Madison, WI 53703-2506  
 Phone: 608-266-4420 • Fax: 608-267-1100 • E-mail: fire@cityofmadison.com

Project Address: 6810 Milwaukee Street
Contact Name & Phone #: Brian Arcand 608-838-0444 x224

## FIRE APPARATUS ACCESS AND FIRE HYDRANT WORKSHEET

1. Is the building completely protected by an NFPA 13 or 13R automatic fire sprinkler system? <b>If non-sprinklered</b> , fire lanes extend to within 150-feet of all portions of the exterior wall? <b>If sprinklered</b> , fire lanes are within 250-feet of all portions of the exterior wall?	<table style="width: 100%; border-collapse: collapse;"> <tr> <td style="text-align: right;">Yes</td> <td><input checked="" type="checkbox"/></td> <td style="text-align: right;">No</td> <td><input type="checkbox"/></td> <td style="text-align: right;">N/A</td> <td><input type="checkbox"/></td> </tr> <tr> <td style="text-align: right;">Yes</td> <td><input type="checkbox"/></td> <td style="text-align: right;">No</td> <td><input type="checkbox"/></td> <td style="text-align: right;">N/A</td> <td><input checked="" type="checkbox"/></td> </tr> <tr> <td style="text-align: right;">Yes</td> <td><input checked="" type="checkbox"/></td> <td style="text-align: right;">No</td> <td><input type="checkbox"/></td> <td style="text-align: right;">N/A</td> <td><input type="checkbox"/></td> </tr> </table>	Yes	<input checked="" type="checkbox"/>	No	<input type="checkbox"/>	N/A	<input type="checkbox"/>	Yes	<input type="checkbox"/>	No	<input type="checkbox"/>	N/A	<input checked="" type="checkbox"/>	Yes	<input checked="" type="checkbox"/>	No	<input type="checkbox"/>	N/A	<input type="checkbox"/>																														
Yes	<input checked="" type="checkbox"/>	No	<input type="checkbox"/>	N/A	<input type="checkbox"/>																																												
Yes	<input type="checkbox"/>	No	<input type="checkbox"/>	N/A	<input checked="" type="checkbox"/>																																												
Yes	<input checked="" type="checkbox"/>	No	<input type="checkbox"/>	N/A	<input type="checkbox"/>																																												
2. Is the fire lane constructed of concrete or asphalt, designed to support a minimum load of 85,000 lbs? a) Is the fire lane a minimum unobstructed width of at least 20-feet? b) Is the fire lane unobstructed with a vertical clearance of at least 13½-feet? c) Is the minimum inside turning radius of the fire lane at least 28-feet? d) Is the grade of the fire lane not more than a slope of 8%? e) Is the fire lane posted as fire lane? (Provide detail of signage.) f) Is a roll-able curb used as part of the fire lane? (Provide detail of curb.) g) Is part of a sidewalk used as part of the required fire lane? (Must support +85,000 lbs.)	<table style="width: 100%; border-collapse: collapse;"> <tr> <td style="text-align: right;">Yes</td> <td><input checked="" type="checkbox"/></td> <td style="text-align: right;">No</td> <td><input type="checkbox"/></td> <td style="text-align: right;">N/A</td> <td><input type="checkbox"/></td> </tr> <tr> <td style="text-align: right;">Yes</td> <td><input checked="" type="checkbox"/></td> <td style="text-align: right;">No</td> <td><input type="checkbox"/></td> <td style="text-align: right;">N/A</td> <td><input type="checkbox"/></td> </tr> <tr> <td style="text-align: right;">Yes</td> <td><input checked="" type="checkbox"/></td> <td style="text-align: right;">No</td> <td><input type="checkbox"/></td> <td style="text-align: right;">N/A</td> <td><input type="checkbox"/></td> </tr> <tr> <td style="text-align: right;">Yes</td> <td><input checked="" type="checkbox"/></td> <td style="text-align: right;">No</td> <td><input type="checkbox"/></td> <td style="text-align: right;">N/A</td> <td><input type="checkbox"/></td> </tr> <tr> <td style="text-align: right;">Yes</td> <td><input checked="" type="checkbox"/></td> <td style="text-align: right;">No</td> <td><input type="checkbox"/></td> <td style="text-align: right;">N/A</td> <td><input type="checkbox"/></td> </tr> <tr> <td style="text-align: right;">Yes</td> <td><input type="checkbox"/></td> <td style="text-align: right;">No</td> <td><input checked="" type="checkbox"/></td> <td style="text-align: right;">N/A</td> <td><input type="checkbox"/></td> </tr> <tr> <td style="text-align: right;">Yes</td> <td><input type="checkbox"/></td> <td style="text-align: right;">No</td> <td><input checked="" type="checkbox"/></td> <td style="text-align: right;">N/A</td> <td><input type="checkbox"/></td> </tr> <tr> <td style="text-align: right;">Yes</td> <td><input type="checkbox"/></td> <td style="text-align: right;">No</td> <td><input checked="" type="checkbox"/></td> <td style="text-align: right;">N/A</td> <td><input type="checkbox"/></td> </tr> </table>	Yes	<input checked="" type="checkbox"/>	No	<input type="checkbox"/>	N/A	<input type="checkbox"/>	Yes	<input checked="" type="checkbox"/>	No	<input type="checkbox"/>	N/A	<input type="checkbox"/>	Yes	<input checked="" type="checkbox"/>	No	<input type="checkbox"/>	N/A	<input type="checkbox"/>	Yes	<input checked="" type="checkbox"/>	No	<input type="checkbox"/>	N/A	<input type="checkbox"/>	Yes	<input checked="" type="checkbox"/>	No	<input type="checkbox"/>	N/A	<input type="checkbox"/>	Yes	<input type="checkbox"/>	No	<input checked="" type="checkbox"/>	N/A	<input type="checkbox"/>	Yes	<input type="checkbox"/>	No	<input checked="" type="checkbox"/>	N/A	<input type="checkbox"/>	Yes	<input type="checkbox"/>	No	<input checked="" type="checkbox"/>	N/A	<input type="checkbox"/>
Yes	<input checked="" type="checkbox"/>	No	<input type="checkbox"/>	N/A	<input type="checkbox"/>																																												
Yes	<input checked="" type="checkbox"/>	No	<input type="checkbox"/>	N/A	<input type="checkbox"/>																																												
Yes	<input checked="" type="checkbox"/>	No	<input type="checkbox"/>	N/A	<input type="checkbox"/>																																												
Yes	<input checked="" type="checkbox"/>	No	<input type="checkbox"/>	N/A	<input type="checkbox"/>																																												
Yes	<input checked="" type="checkbox"/>	No	<input type="checkbox"/>	N/A	<input type="checkbox"/>																																												
Yes	<input type="checkbox"/>	No	<input checked="" type="checkbox"/>	N/A	<input type="checkbox"/>																																												
Yes	<input type="checkbox"/>	No	<input checked="" type="checkbox"/>	N/A	<input type="checkbox"/>																																												
Yes	<input type="checkbox"/>	No	<input checked="" type="checkbox"/>	N/A	<input type="checkbox"/>																																												
3. Is the fire lane obstructed by security gates or barricades? If yes: a) Is the gate a minimum of 20-foot clear opening? b) Is an approved means of emergency operations installed, key vault, padlock or key switch?	<table style="width: 100%; border-collapse: collapse;"> <tr> <td style="text-align: right;">Yes</td> <td><input type="checkbox"/></td> <td style="text-align: right;">No</td> <td><input checked="" type="checkbox"/></td> <td style="text-align: right;">N/A</td> <td><input type="checkbox"/></td> </tr> <tr> <td style="text-align: right;">Yes</td> <td><input type="checkbox"/></td> <td style="text-align: right;">No</td> <td><input type="checkbox"/></td> <td style="text-align: right;">N/A</td> <td><input checked="" type="checkbox"/></td> </tr> <tr> <td style="text-align: right;">Yes</td> <td><input type="checkbox"/></td> <td style="text-align: right;">No</td> <td><input type="checkbox"/></td> <td style="text-align: right;">N/A</td> <td><input checked="" type="checkbox"/></td> </tr> </table>	Yes	<input type="checkbox"/>	No	<input checked="" type="checkbox"/>	N/A	<input type="checkbox"/>	Yes	<input type="checkbox"/>	No	<input type="checkbox"/>	N/A	<input checked="" type="checkbox"/>	Yes	<input type="checkbox"/>	No	<input type="checkbox"/>	N/A	<input checked="" type="checkbox"/>																														
Yes	<input type="checkbox"/>	No	<input checked="" type="checkbox"/>	N/A	<input type="checkbox"/>																																												
Yes	<input type="checkbox"/>	No	<input type="checkbox"/>	N/A	<input checked="" type="checkbox"/>																																												
Yes	<input type="checkbox"/>	No	<input type="checkbox"/>	N/A	<input checked="" type="checkbox"/>																																												
4. Is the Fire lane dead-ended with a length greater than 150-feet? If yes, does the area for turning around fire apparatus comply with IFC D103?	<table style="width: 100%; border-collapse: collapse;"> <tr> <td style="text-align: right;">Yes</td> <td><input type="checkbox"/></td> <td style="text-align: right;">No</td> <td><input checked="" type="checkbox"/></td> <td style="text-align: right;">N/A</td> <td><input type="checkbox"/></td> </tr> <tr> <td style="text-align: right;">Yes</td> <td><input type="checkbox"/></td> <td style="text-align: right;">No</td> <td><input type="checkbox"/></td> <td style="text-align: right;">N/A</td> <td><input checked="" type="checkbox"/></td> </tr> </table>	Yes	<input type="checkbox"/>	No	<input checked="" type="checkbox"/>	N/A	<input type="checkbox"/>	Yes	<input type="checkbox"/>	No	<input type="checkbox"/>	N/A	<input checked="" type="checkbox"/>																																				
Yes	<input type="checkbox"/>	No	<input checked="" type="checkbox"/>	N/A	<input type="checkbox"/>																																												
Yes	<input type="checkbox"/>	No	<input type="checkbox"/>	N/A	<input checked="" type="checkbox"/>																																												
5. Is any portion of the building to be used for high-piled storage in accordance with IFC Chapter 3206.6 If yes, see IFC 3206.6 for further requirements.	<table style="width: 100%; border-collapse: collapse;"> <tr> <td style="text-align: right;">Yes</td> <td><input type="checkbox"/></td> <td style="text-align: right;">No</td> <td><input checked="" type="checkbox"/></td> <td style="text-align: right;">N/A</td> <td><input type="checkbox"/></td> </tr> </table>	Yes	<input type="checkbox"/>	No	<input checked="" type="checkbox"/>	N/A	<input type="checkbox"/>																																										
Yes	<input type="checkbox"/>	No	<input checked="" type="checkbox"/>	N/A	<input type="checkbox"/>																																												
6. Is any part of the building greater than 30-feet above the grade plane? If yes, answer the following questions: a) Is the aerial apparatus fire lane parallel to one entire side of the building and covering at least 25% of the perimeter? b) Is the near edge of the aerial apparatus fire lane between 15' and 30' from the building? c) Are there any overhead power or utility lines located across the aerial apparatus fire lane? d) Are there any tree canopies expected to grow across the aerial fire lane? (Based on mature canopy width of tree species) e) Does the aerial apparatus fire lane have a minimum unobstructed width of 26-feet? f) Is the space between the aerial lane and the building free of trees exceeding 20' in heights?	<table style="width: 100%; border-collapse: collapse;"> <tr> <td style="text-align: right;">Yes</td> <td><input checked="" type="checkbox"/></td> <td style="text-align: right;">No</td> <td><input type="checkbox"/></td> <td style="text-align: right;">N/A</td> <td><input type="checkbox"/></td> </tr> <tr> <td style="text-align: right;">Yes</td> <td><input checked="" type="checkbox"/></td> <td style="text-align: right;">No</td> <td><input type="checkbox"/></td> <td style="text-align: right;">N/A</td> <td><input type="checkbox"/></td> </tr> <tr> <td style="text-align: right;">Yes</td> <td><input checked="" type="checkbox"/></td> <td style="text-align: right;">No</td> <td><input type="checkbox"/></td> <td style="text-align: right;">N/A</td> <td><input type="checkbox"/></td> </tr> <tr> <td style="text-align: right;">Yes</td> <td><input type="checkbox"/></td> <td style="text-align: right;">No</td> <td><input checked="" type="checkbox"/></td> <td style="text-align: right;">N/A</td> <td><input type="checkbox"/></td> </tr> <tr> <td style="text-align: right;">Yes</td> <td><input type="checkbox"/></td> <td style="text-align: right;">No</td> <td><input checked="" type="checkbox"/></td> <td style="text-align: right;">N/A</td> <td><input type="checkbox"/></td> </tr> <tr> <td style="text-align: right;">Yes</td> <td><input checked="" type="checkbox"/></td> <td style="text-align: right;">No</td> <td><input type="checkbox"/></td> <td style="text-align: right;">N/A</td> <td><input type="checkbox"/></td> </tr> <tr> <td style="text-align: right;">Yes</td> <td><input checked="" type="checkbox"/></td> <td style="text-align: right;">No</td> <td><input type="checkbox"/></td> <td style="text-align: right;">N/A</td> <td><input type="checkbox"/></td> </tr> </table>	Yes	<input checked="" type="checkbox"/>	No	<input type="checkbox"/>	N/A	<input type="checkbox"/>	Yes	<input checked="" type="checkbox"/>	No	<input type="checkbox"/>	N/A	<input type="checkbox"/>	Yes	<input checked="" type="checkbox"/>	No	<input type="checkbox"/>	N/A	<input type="checkbox"/>	Yes	<input type="checkbox"/>	No	<input checked="" type="checkbox"/>	N/A	<input type="checkbox"/>	Yes	<input type="checkbox"/>	No	<input checked="" type="checkbox"/>	N/A	<input type="checkbox"/>	Yes	<input checked="" type="checkbox"/>	No	<input type="checkbox"/>	N/A	<input type="checkbox"/>	Yes	<input checked="" type="checkbox"/>	No	<input type="checkbox"/>	N/A	<input type="checkbox"/>						
Yes	<input checked="" type="checkbox"/>	No	<input type="checkbox"/>	N/A	<input type="checkbox"/>																																												
Yes	<input checked="" type="checkbox"/>	No	<input type="checkbox"/>	N/A	<input type="checkbox"/>																																												
Yes	<input checked="" type="checkbox"/>	No	<input type="checkbox"/>	N/A	<input type="checkbox"/>																																												
Yes	<input type="checkbox"/>	No	<input checked="" type="checkbox"/>	N/A	<input type="checkbox"/>																																												
Yes	<input type="checkbox"/>	No	<input checked="" type="checkbox"/>	N/A	<input type="checkbox"/>																																												
Yes	<input checked="" type="checkbox"/>	No	<input type="checkbox"/>	N/A	<input type="checkbox"/>																																												
Yes	<input checked="" type="checkbox"/>	No	<input type="checkbox"/>	N/A	<input type="checkbox"/>																																												
7. Are all portions of the required fire lanes within 500-feet of at least (2) hydrants? <i>Note: Distances shall be measured along the path of the hose lay as it comes off the fire apparatus.</i> a) Is the fire lane at least 26' wide for at least 20-feet on each side of the hydrants? b) Is there at least 40' between a hydrant and the building? c) Are the hydrant(s) setback no less than 5-feet nor more than 10-feet from the curb or edge of the street or fire lane? d) Are hydrants located in parking lot islands a minimum of 3½-feet from the hydrant to the curb? e) Are there no obstructions, including but not limited to: power poles, trees, bushes, fences, posts located, or grade changes exceeding 1½-feet, within 5-feet of a fire hydrant?	<table style="width: 100%; border-collapse: collapse;"> <tr> <td style="text-align: right;">Yes</td> <td><input checked="" type="checkbox"/></td> <td style="text-align: right;">No</td> <td><input type="checkbox"/></td> <td style="text-align: right;">N/A</td> <td><input type="checkbox"/></td> </tr> <tr> <td style="text-align: right;">Yes</td> <td><input checked="" type="checkbox"/></td> <td style="text-align: right;">No</td> <td><input type="checkbox"/></td> <td style="text-align: right;">N/A</td> <td><input type="checkbox"/></td> </tr> <tr> <td style="text-align: right;">Yes</td> <td><input checked="" type="checkbox"/></td> <td style="text-align: right;">No</td> <td><input type="checkbox"/></td> <td style="text-align: right;">N/A</td> <td><input type="checkbox"/></td> </tr> <tr> <td style="text-align: right;">Yes</td> <td><input checked="" type="checkbox"/></td> <td style="text-align: right;">No</td> <td><input type="checkbox"/></td> <td style="text-align: right;">N/A</td> <td><input type="checkbox"/></td> </tr> <tr> <td style="text-align: right;">Yes</td> <td><input checked="" type="checkbox"/></td> <td style="text-align: right;">No</td> <td><input type="checkbox"/></td> <td style="text-align: right;">N/A</td> <td><input type="checkbox"/></td> </tr> <tr> <td style="text-align: right;">Yes</td> <td><input checked="" type="checkbox"/></td> <td style="text-align: right;">No</td> <td><input type="checkbox"/></td> <td style="text-align: right;">N/A</td> <td><input type="checkbox"/></td> </tr> </table>	Yes	<input checked="" type="checkbox"/>	No	<input type="checkbox"/>	N/A	<input type="checkbox"/>	Yes	<input checked="" type="checkbox"/>	No	<input type="checkbox"/>	N/A	<input type="checkbox"/>	Yes	<input checked="" type="checkbox"/>	No	<input type="checkbox"/>	N/A	<input type="checkbox"/>	Yes	<input checked="" type="checkbox"/>	No	<input type="checkbox"/>	N/A	<input type="checkbox"/>	Yes	<input checked="" type="checkbox"/>	No	<input type="checkbox"/>	N/A	<input type="checkbox"/>	Yes	<input checked="" type="checkbox"/>	No	<input type="checkbox"/>	N/A	<input type="checkbox"/>												
Yes	<input checked="" type="checkbox"/>	No	<input type="checkbox"/>	N/A	<input type="checkbox"/>																																												
Yes	<input checked="" type="checkbox"/>	No	<input type="checkbox"/>	N/A	<input type="checkbox"/>																																												
Yes	<input checked="" type="checkbox"/>	No	<input type="checkbox"/>	N/A	<input type="checkbox"/>																																												
Yes	<input checked="" type="checkbox"/>	No	<input type="checkbox"/>	N/A	<input type="checkbox"/>																																												
Yes	<input checked="" type="checkbox"/>	No	<input type="checkbox"/>	N/A	<input type="checkbox"/>																																												
Yes	<input checked="" type="checkbox"/>	No	<input type="checkbox"/>	N/A	<input type="checkbox"/>																																												

*Note: Hydrants shall be installed and in-service prior to combustible construction on the project site.*

Attach an additional sheet if further explanation is required for any answers.

This worksheet is based on MGO 34.503 and IFC 2015 Edition Chapter 5 and Appendix D; please see the codes for further information.

I:\Projects\2018\118.1129.30\MEADOWLANDS\FIRE.dwg, 5/22/2019 3:02:21 PM, User: JAC, AUG/CAD, PDF, General Document, 118.1129.30\MEADOWLANDS\FIRE.dwg, 5/22/2019 3:02:21 PM, User: JAC, AUG/CAD, PDF, General Document, 118.1129.30\MEADOWLANDS\FIRE.dwg

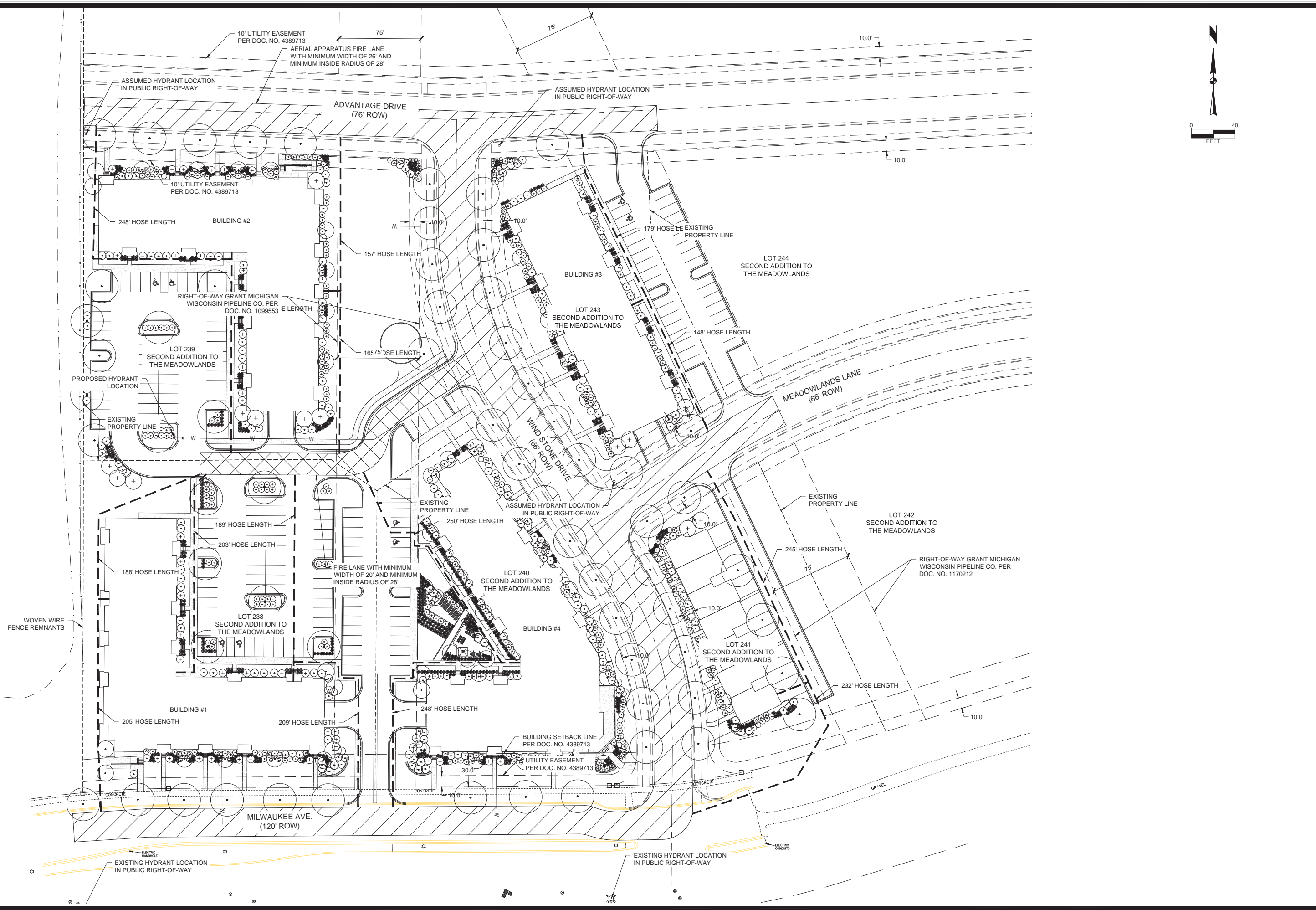

MARK	REVISION	DATE	BY
Engineer: BCA	Checked By: MLC	Scale: 1" = AS SHOWN	
Technician: BCA	Date: 05-22-2019	T-R-S:	
Surveyed By:	Date:		
Project No: 118.1129.30			

**THE MEADOWLANDS - PHASE 11**  
**FIRE ACCESS PLAN**

**MADISON, WI**

**SNYDER & ASSOCIATES, INC.**

5010 VOGES ROAD  
MADISON, WI 53718  
608-838-0444 | www.snyder-associates.com



**SNYDER & ASSOCIATES**

118.1129.30  
**EXHIBIT**

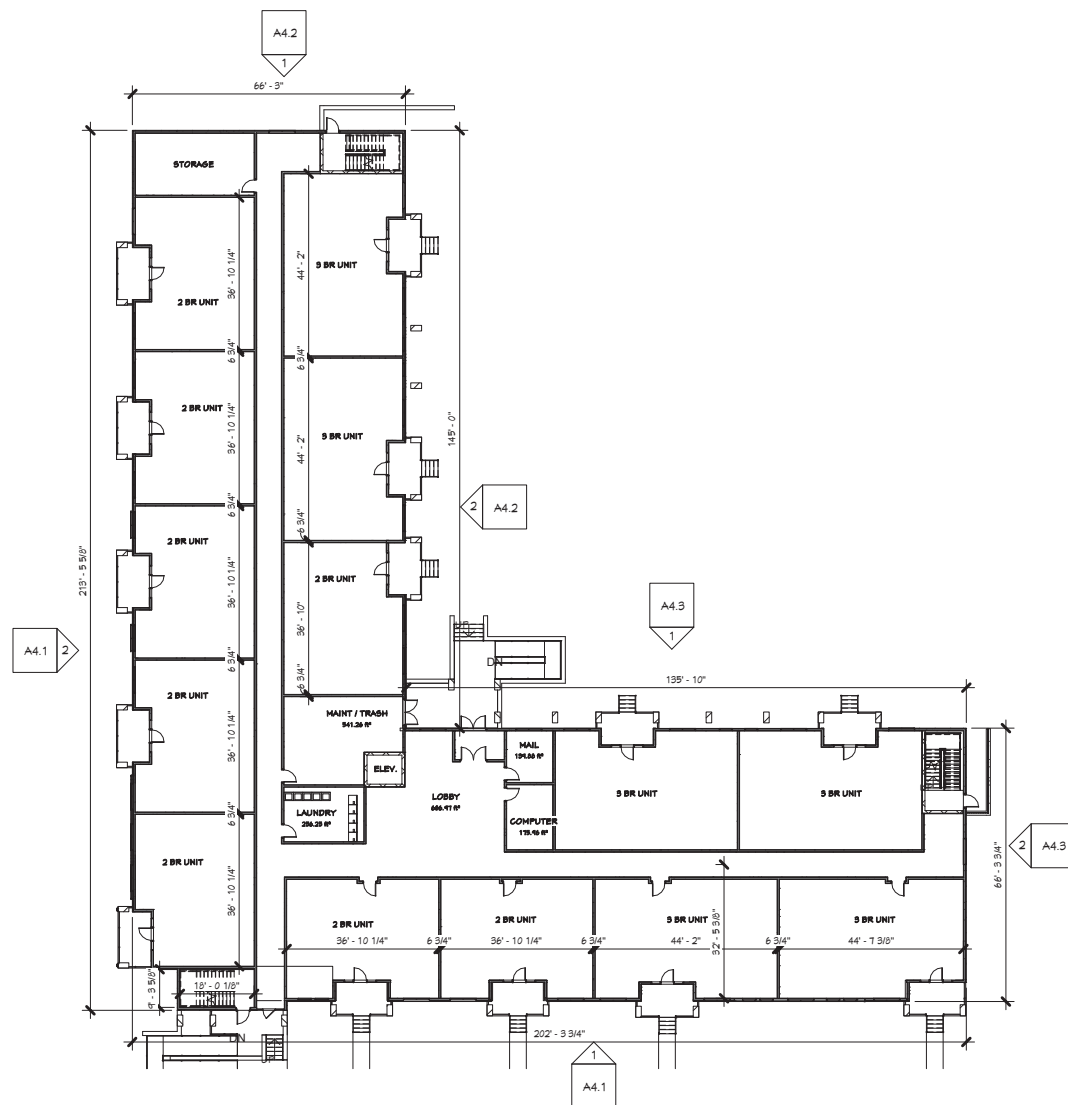

**BLDG 1 - MAIN LEVEL PLAN**  
 3/64" = 1'-0"

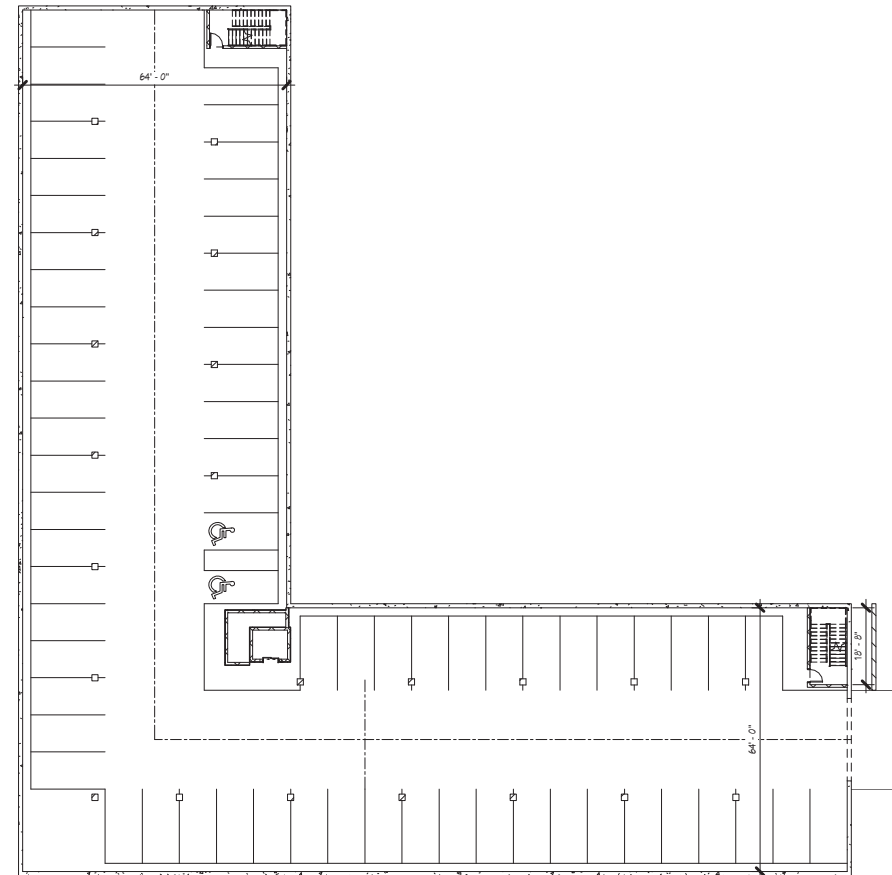

**BLDG 1 - PARKING LEVEL PLAN**  
 3/64" = 1'-0"

H

DJ

HOOKER | DE JONG  
 Architects & Engineers  
 316 Morris Avenue  
 Studio Suite 410  
 Muskegon, MI 49440  
 P 231 | 722 | 3407  
 F 231 | 722 | 2589

MULTI-FAMILY HOUSING  
THE MEADOWLANDS  
 MADISON, WI  
 KGC HOUSING DEVELOPMENT

Project Number		4-1125
ISSUANCE		
No.	Date	Description
1	2019.05.28	SITE PLAN REVIEW

Copyright © 2019 HDJ Inc. All Rights Reserved.

OVERALL FLOOR  
 PLANS - BLDG 1  
 (BLDG 2 SIM.)

A0.1

NOT FOR  
 CONSTRUCTION

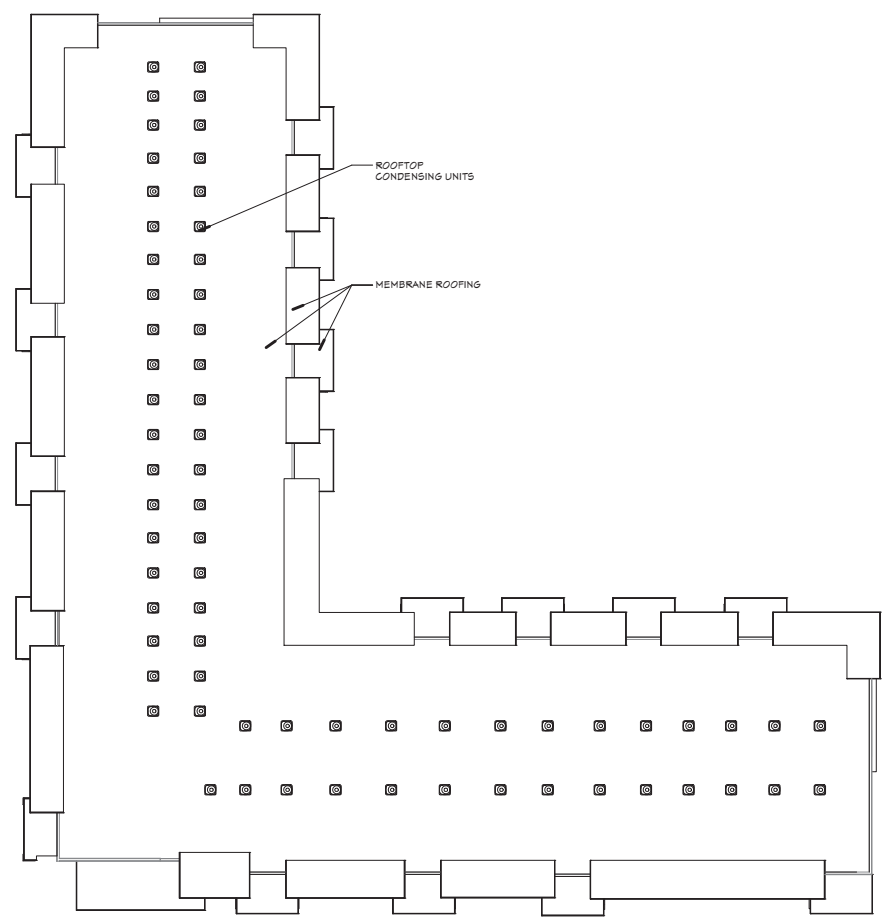

**ROOF PLAN**  
3/16" = 1'-0"

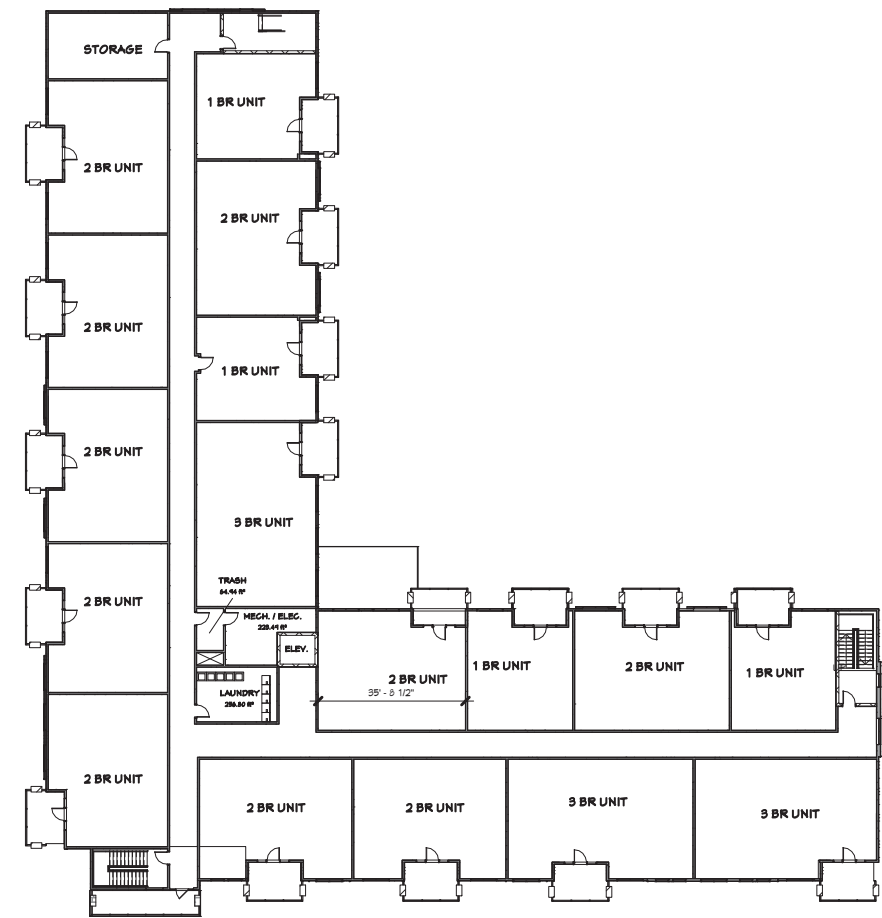

**BLDG 1 - SECOND FLOOR PLAN**  
3/16" = 1'-0"

(THIRD AND FOURTH SIM.)

Project Number		4-1125
ISSUANCE		
No.	Date	Description
1	2019.05.28	SITE PLAN REVIEW

NOT FOR CONSTRUCTION

Copyright © 2019 HDJ Inc. All Rights Reserved

OVERALL FLOOR PLANS - BLDG 1  
(BLDG 2 SIM.)

A0.2

5/29/2019 2:07:18 PM  
 C:\I-Revit\Projects\4-1125 - ARCH\_arch\ent(Recovery).rvt

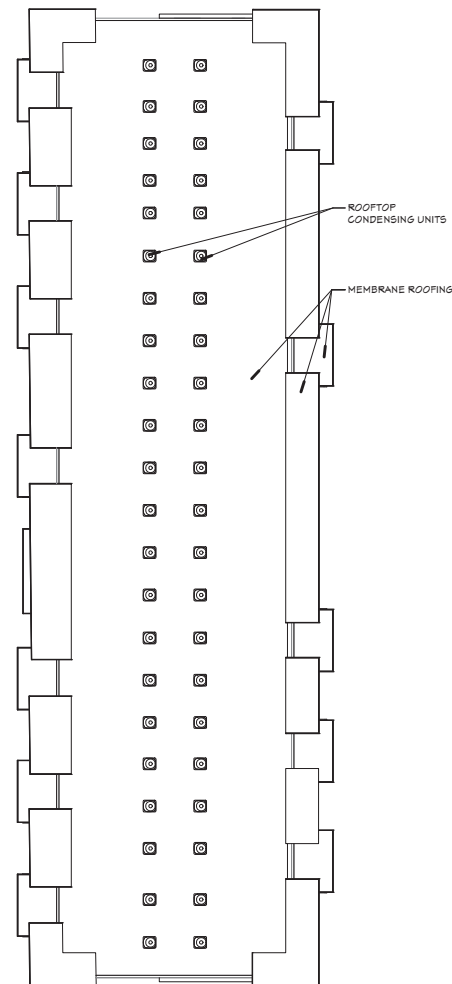

**BLDG 3 - ROOF PLAN**  
 3/64" = 1'-0"

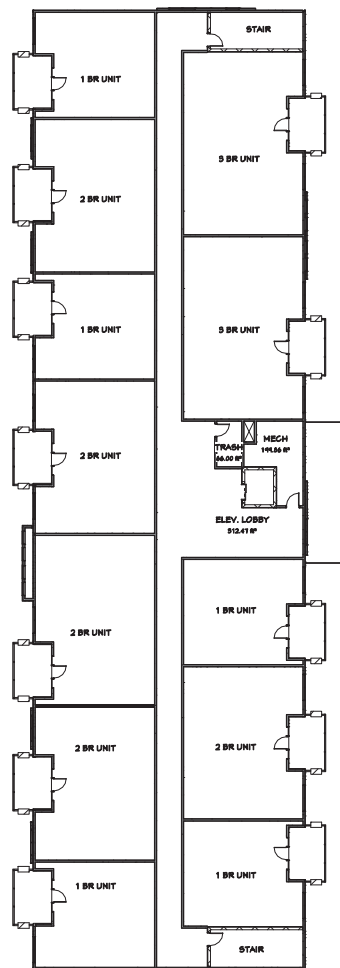

**BLDG 3 - SECOND FLOOR**  
 3/64" = 1'-0"  
 (THIRD AND FOURTH FLOOR SIM.)

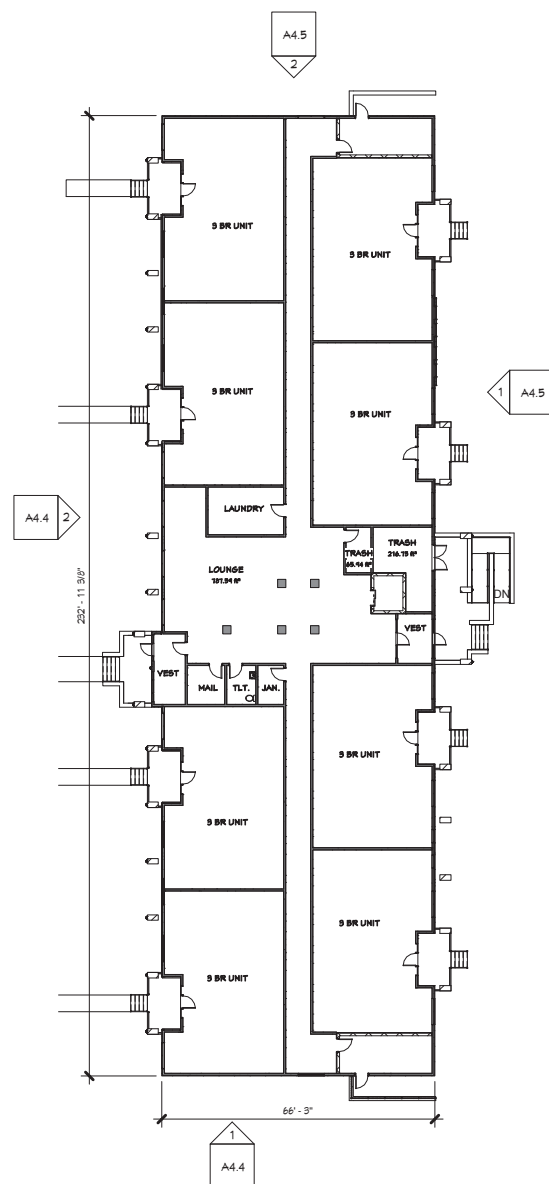

**BLDG 3 - FIRST FLOOR**  
 3/64" = 1'-0"

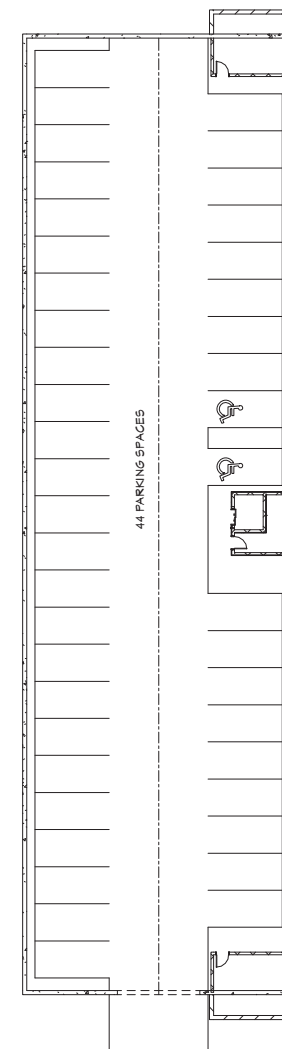

**BLDG 3 - PARKING LEVEL**  
 3/64" = 1'-0"

H  
 DJ  
 HOOKER | DE JONG  
 Architects & Engineers  
 316 Morris Avenue  
 Studio Suite 410  
 Muskegon, MI 49440  
 P 231 | 722 | 3407  
 F 231 | 722 | 2589

MULTI-FAMILY HOUSING  
**THE MEADOWLANDS**  
 MADISON, WI  
 KGC HOUSING DEVELOPMENT

Project Number 4-1125

ISSUANCE		
No.	Date	Description
1	2019.05.28	SITE PLAN REVIEW

NOT FOR CONSTRUCTION

Copyright © 2019 HDJ Inc. All Rights Reserved

OVERALL FLOOR PLANS - BLDG 3

**A0.3**



H

DJ

HOOKER | DE JONG  
Architects & Engineers  
316 Morris Avenue  
Studio Suite 410  
Muskegon, MI 49440  
P 231 | 722 | 3407  
F 231 | 722 | 2589

MULTI-FAMILY HOUSING  
**THE MEADOWLANDS**  
MADISON, WI  
KGC HOUSING DEVELOPMENT

Project Number 4-1125

ISSUANCE	No.	Date	Description
	1	2019.05.28	SITE PLAN REVIEW

NOT FOR CONSTRUCTION

Copyright © 2019 HDJ Inc. All Rights Reserved

OVERALL FLOOR PLANS - BLDG 4

A0.4

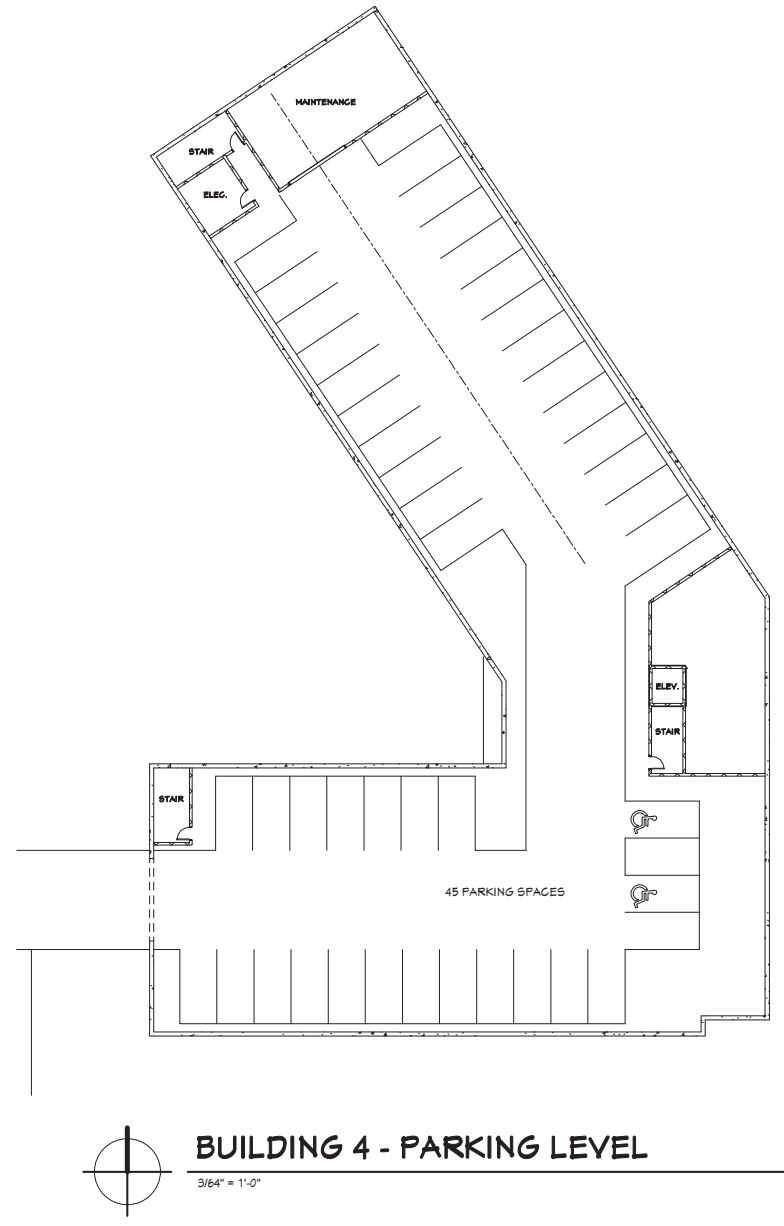
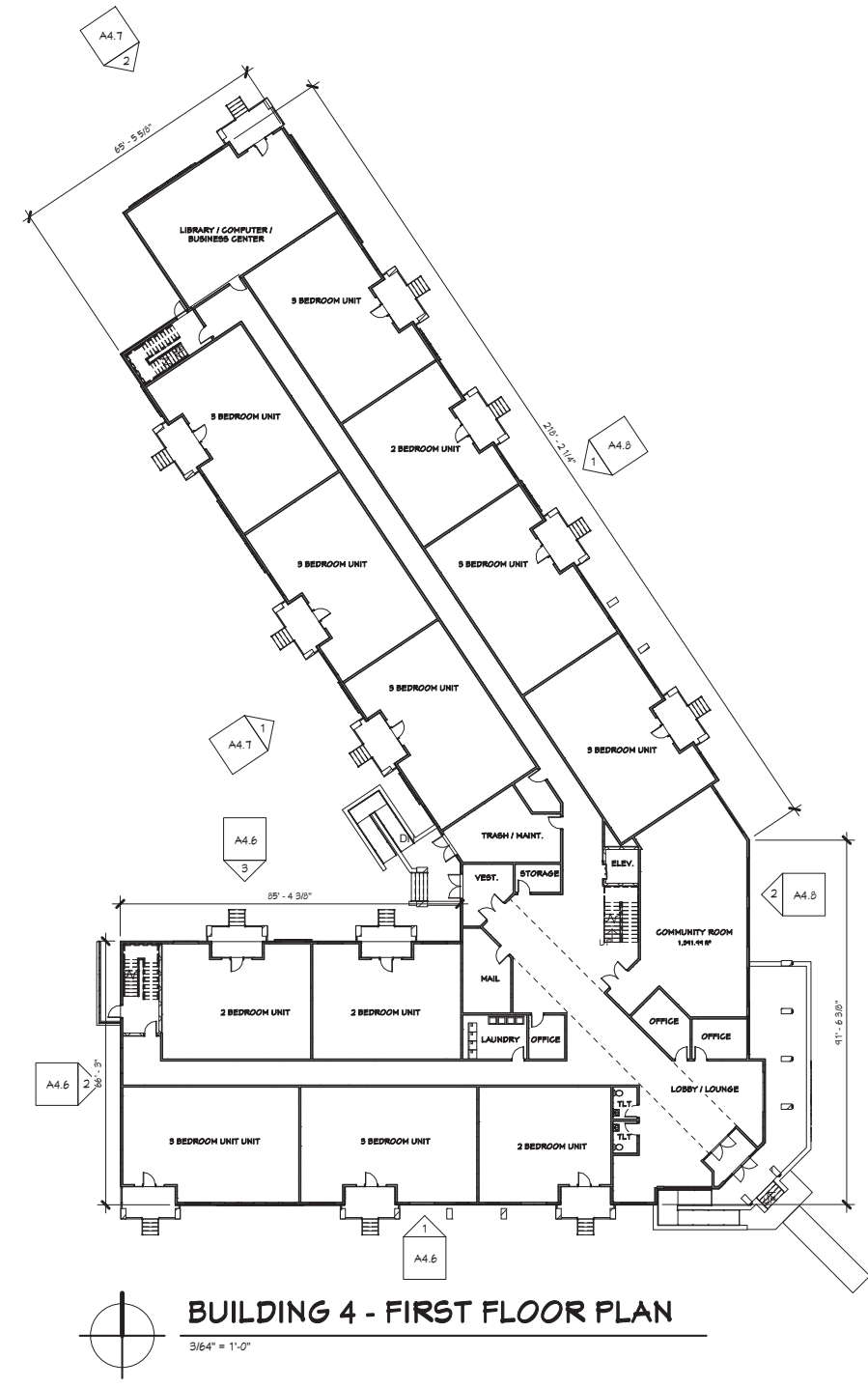

H

DJ

HOOKER | DE JONG  
Architects & Engineers  
316 Morris Avenue  
Studio Suite 410  
Muskegon, MI 49440  
P 231 / 722 / 3407  
F 231 / 722 / 2589

MULTI-FAMILY HOUSING  
**THE MEADOWLANDS**  
MADISON, WI  
KGC HOUSING DEVELOPMENT

Project Number 4-1125

ISSUANCE		
No.	Date	Description
1	2019.05.28	SITE PLAN REVIEW

NOT FOR CONSTRUCTION

Copyright © 2019 HDJ Inc. All Rights Reserved

OVERALL FLOOR PLANS - BLDG 4

A0.5

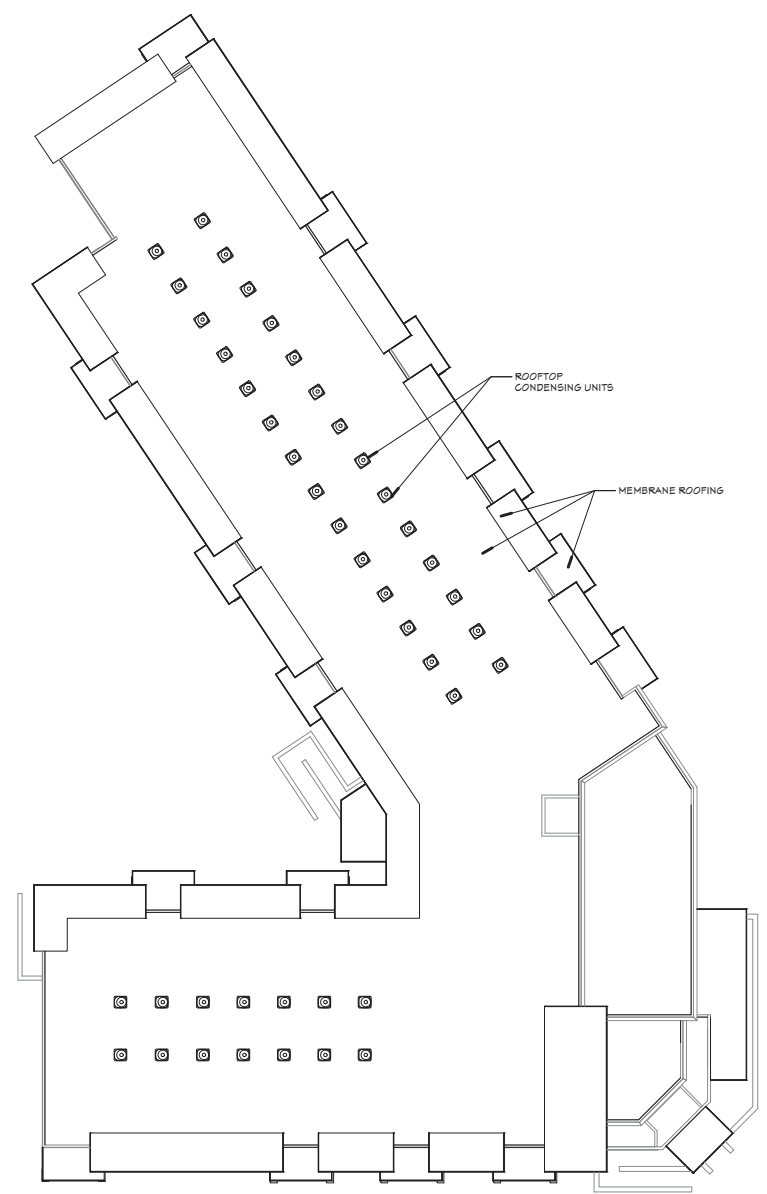

ROOF PLAN

3/64" = 1'-0"

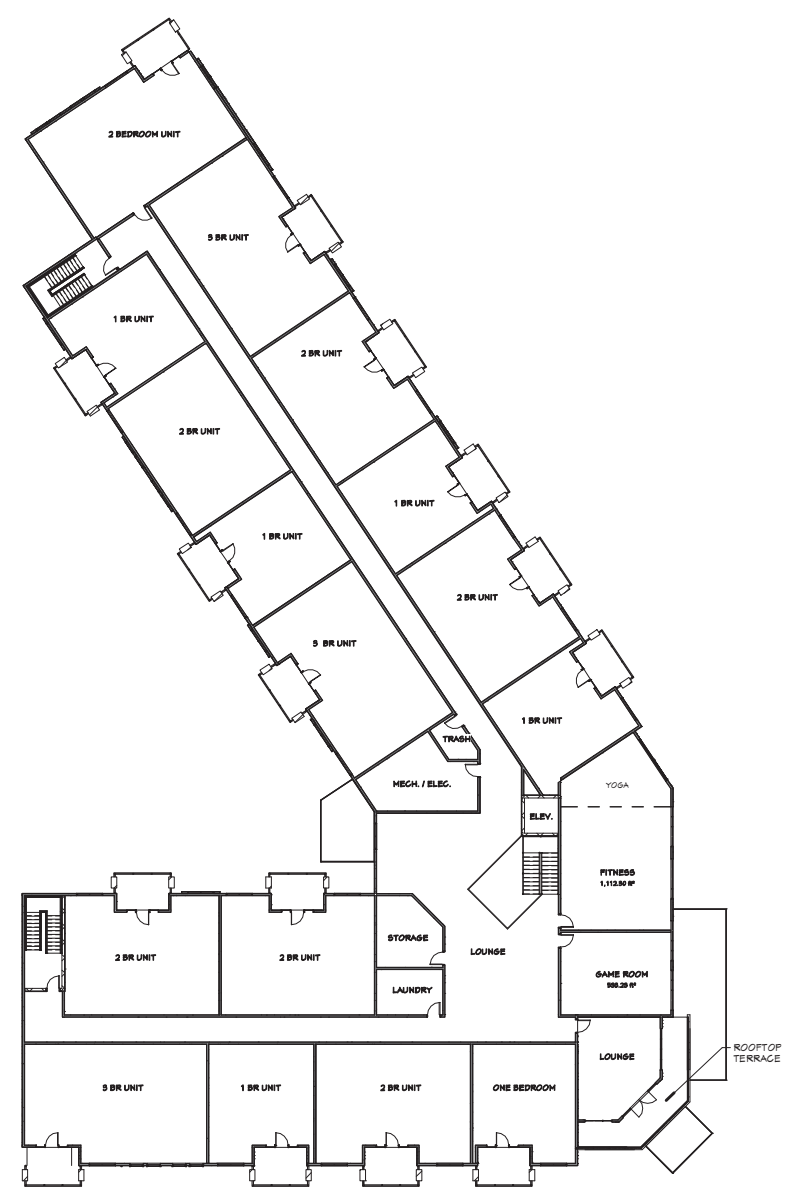

BUILDING 4 - SECOND FLOOR PLAN

3/64" = 1'-0"

(THIRD FLOOR SIM.)

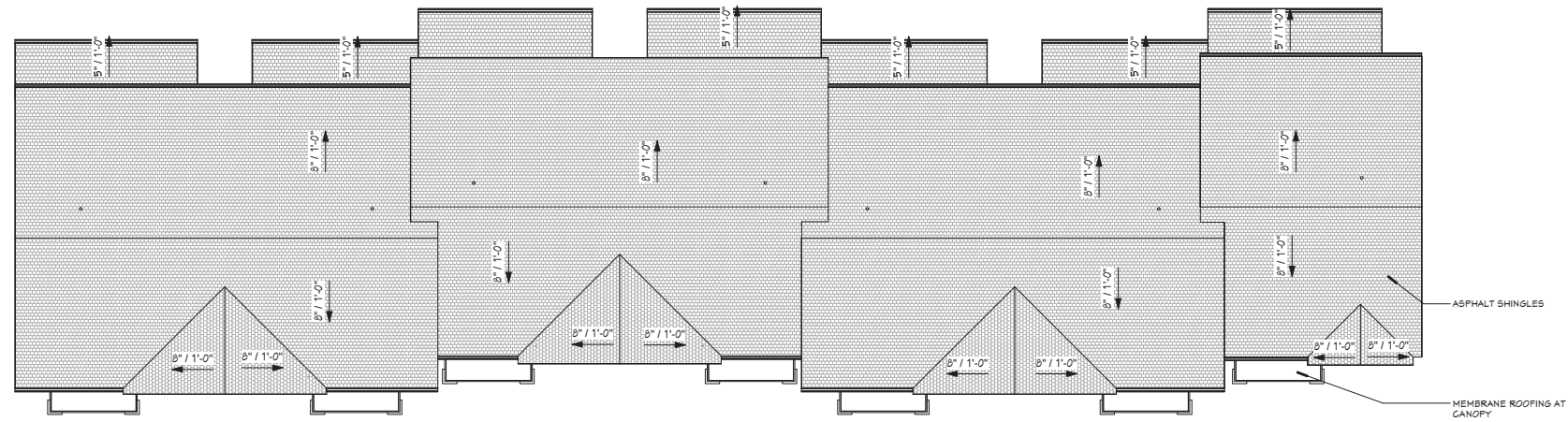

3 OVERALL ROOF PLAN - BLDG 5  
A0.6 3/32" = 1'-0"

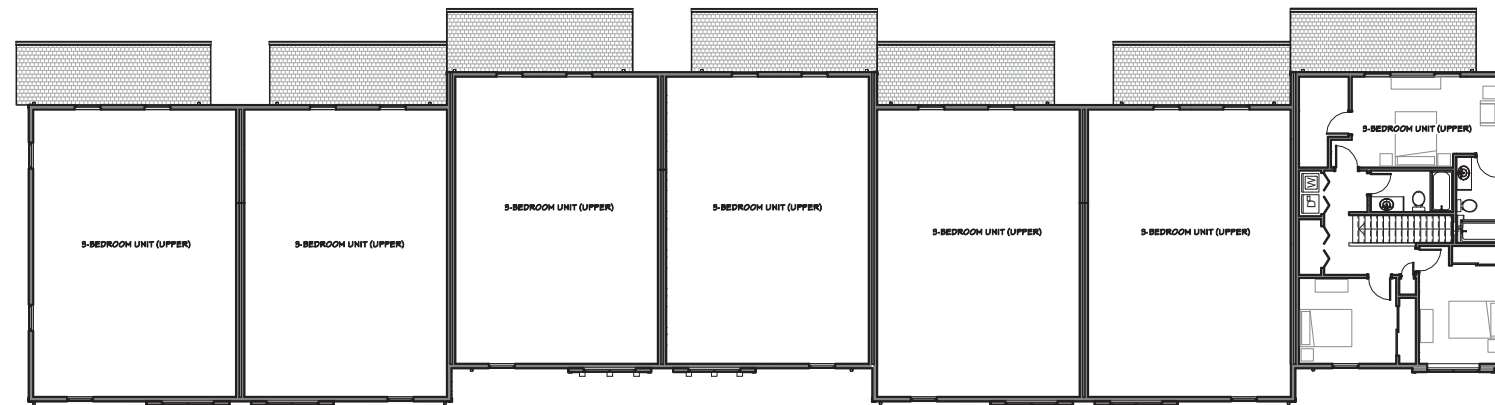

2 OVERALL SECOND FLOOR PLAN - BLDG 5  
A0.6 3/32" = 1'-0"

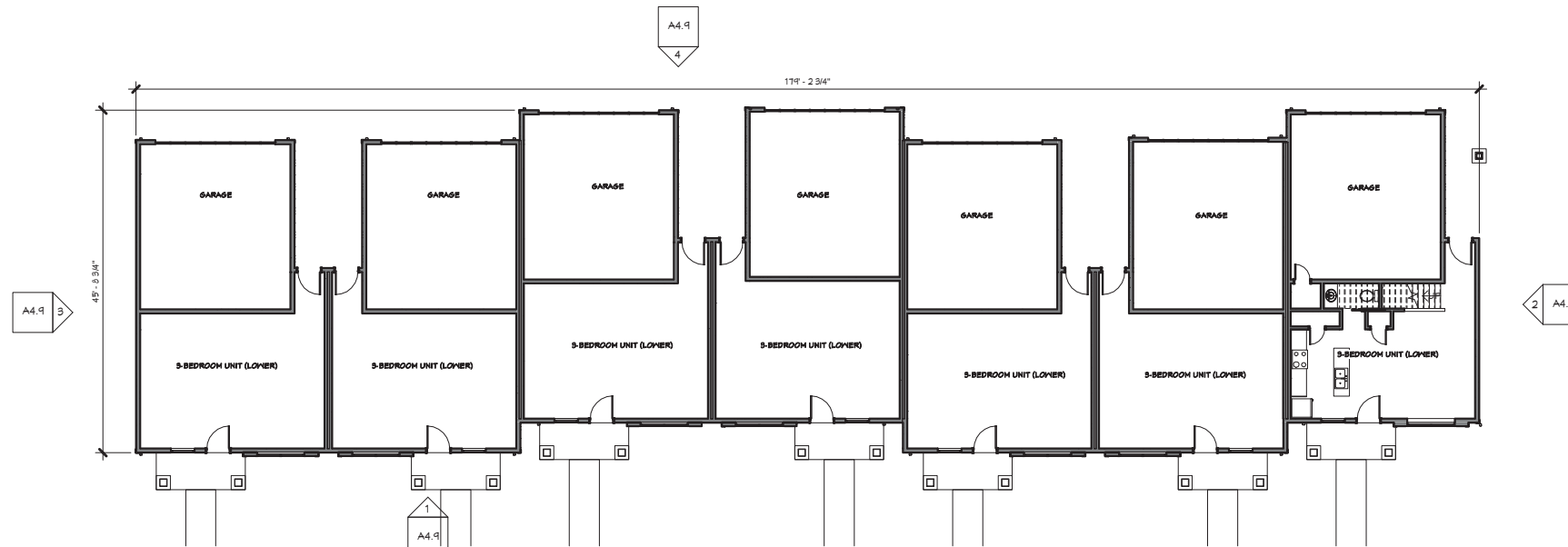

1 OVERALL FIRST FLOOR PLAN - BLDG 5  
A0.6 3/32" = 1'-0"

H

DJ

HOOKER | DE JONG  
Architects & Engineers  
316 Morris Avenue  
Studio Suite 410  
Muskegon, MI 49440  
P 231.722.1340  
F 231.722.1259

MULTI-FAMILY HOUSING  
**THE MEADOWLANDS**  
MADISON, WI  
KGC HOUSING DEVELOPMENT

Project Number 4-1125

ISSUANCE		
No.	Date	Description
1	2019.05.28	SITE PLAN REVIEW

NOT FOR CONSTRUCTION

Copyright © 2019 HDJ Inc. All Rights Reserved

OVERALL FLOOR PLANS - BLDG 5

A0.6

**ELEVATION KEYNOTES**

1. HORIZONTAL FIBER CEMENT SIDING - COLOR 1
2. HORIZONTAL FIBER CEMENT SIDING - COLOR 2
3. FIBER CEMENT TRIM
4. FIBER CEMENT TRIM
5. STONE VENEER
6. CAST STONE SILL
7. VINYL WINDOW WITH FIBER CEMENT TRIM
8. FIBERGLASS DOOR
9. BALCONY CANOPY COLUMN WITH STONE VENEER
10. BALCONY CANOPY COLUMN WITH FIBER CEMENT WRAP
11. FIBER CEMENT FASCIA
12. MECHANICAL UNIT
13. DECORATIVE LIGHT FIXTURE
14. COMPOSITE CORSEL
15. BALCONY STRUCTURE WITH FIBER CEMENT TRIM
16. PAINTED METAL GUARDRAIL
17. ALUMINUM STOREFRONT SYSTEM
18. BUILDING SIGNAGE
19. ALUMINUM GUTTER AND DOWNSPOUTS
20. MECHANICAL PENETRATION
21. ASPHALT SHINGLES
22. INSULATED GARAGE DOOR

**GENERAL ELEVATION NOTES**

1. MECHANICAL PENETRATIONS AT 3 AND 4 STORY BUILDINGS TO EXTEND THROUGH ROOF, BELOW PARAPET LEVEL



**2 BUILDING 1 - WEST ELEVATION**  
A4.1 1/8" = 1'-0"



**1 BUILDING 1 - SOUTH ELEVATION**  
A4.1 1/8" = 1'-0"

H

DJ

HOOKER DE JONG  
Architects & Engineers  
316 Morris Avenue  
Studio Suite 410  
Muskegon, MI 49440  
P 231.722.1307  
F 231.722.1250

MULTI-FAMILY HOUSING  
**THE MEADOWLANDS**  
MADISON, WI  
KGC HOUSING DEVELOPMENT

Project Number **4-1125**

ISSUANCE		Description
No.	Date	
1	2019.05.28	SITE PLAN REVIEW

NOT FOR CONSTRUCTION

Copyright © 2019 HDJ Inc. All Rights Reserved.

EXTERIOR ELEVATIONS

**A4.1**



2 BUILDING 1 - EAST ELEVATION  
A4.2 1/8" = 1'-0"

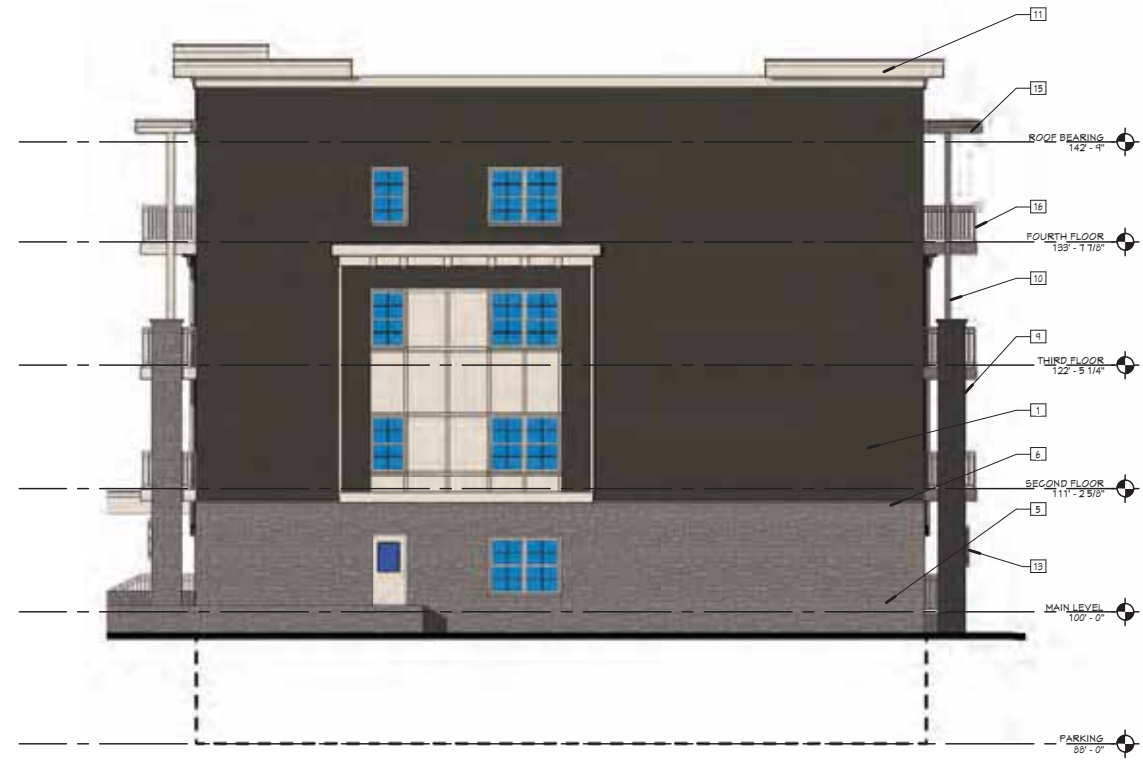

1 BUILDING 1 - NORTH ELEVATION  
A4.2 1/8" = 1'-0"

ELEVATION KEYNOTES

1. HORIZONTAL FIBER CEMENT SIDING - COLOR 1
2. HORIZONTAL FIBER CEMENT SIDING - COLOR 2
3. FIBER CEMENT PANEL
4. FIBER CEMENT TRIM
5. STONE VENEER
6. CAST STONE SILL
7. VINYL WINDOW WITH FIBER CEMENT TRIM
8. FIBERGLASS DOOR
9. BALCONY CANOPY COLUMN WITH STONE VENEER
10. BALCONY CANOPY COLUMN WITH FIBER CEMENT WRAP
11. FIBER CEMENT FASCIA
12. MECHANICAL UNIT
13. DECORATIVE LIGHT FIXTURE
14. COMPOSITE CORBEL
15. BALCONY STRUCTURE WITH FIBER CEMENT TRIM
16. PAINTED METAL GUARDRAIL
17. ALUMINUM STOREFRONT SYSTEM
18. BUILDING SIGNAGE
19. ALUMINUM GUTTER AND DOWNSPOUTS
20. MECHANICAL PENETRATION
21. ASPHALT SHINGLES
22. INSULATED GARAGE DOOR

GENERAL ELEVATION NOTES

1. MECHANICAL PENETRATIONS AT 3 AND 4 STORY BUILDINGS TO EXTEND THROUGH ROOF, BELOW PARAPET LEVEL

H

DJ

HOOKER | DE JONG  
Architects & Engineers  
318 Morris Avenue  
Studio Suite 410  
Muskegon, MI 49440  
P 231 / 722 / 3407  
F 231 / 722 / 2589

MULTI-FAMILY HOUSING  
**THE MEADOWLANDS**  
MADISON, WI  
KGC HOUSING DEVELOPMENT

Project Number 4-1125

ISSUANCE		
No.	Date	Description
1	2019.05.28	SITE PLAN REVIEW

NOT FOR CONSTRUCTION

Copyright © 2019 HDJ Inc. All Rights Reserved

EXTERIOR ELEVATIONS

A4.2

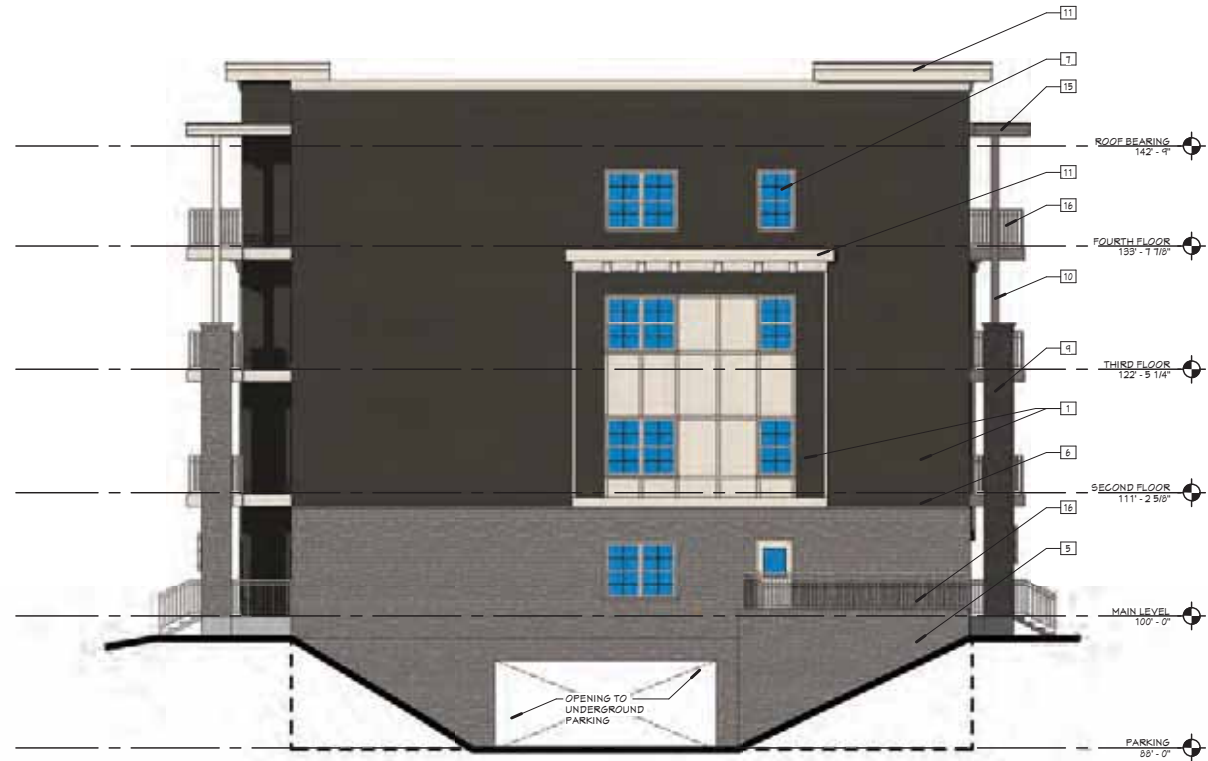

2 BUILDING 1 - EAST ELEVATION  
 A4.3 1/8" = 1'-0"



1 BUILDING 1 - NORTH ELEVATION  
 A4.3 1/8" = 1'-0"

**ELEVATION KEYNOTES**

1. HORIZONTAL FIBER CEMENT SIDING - COLOR 1
2. HORIZONTAL FIBER CEMENT SIDING - COLOR 2
3. FIBER CEMENT PANEL
4. FIBER CEMENT TRIM
5. STONE VENEER
6. CAST STONE SILL
7. VINYL WINDOW WITH FIBER CEMENT TRIM
8. FIBERGLASS DOOR
9. BALCONY CANOPY COLUMN WITH STONE VENEER
10. BALCONY CANOPY COLUMN WITH FIBER CEMENT WRAP
11. FIBER CEMENT FASCIA
12. MECHANICAL UNIT
13. DECORATIVE LIGHT FIXTURE
14. COMPOSITE CORBEL
15. BALCONY STRUCTURE WITH FIBER CEMENT TRIM
16. PAINTED METAL GUARDRAIL
17. ALUMINUM STOREFRONT SYSTEM
18. BUILDING SIGNAGE
19. ALUMINUM GUTTER AND DOWNSPOUTS
20. MECHANICAL PENETRATION
21. ASPHALT SHINGLES
22. INSULATED GARAGE DOOR

**GENERAL ELEVATION NOTES**

1. MECHANICAL PENETRATIONS AT 3 AND 4 STORY BUILDINGS TO EXTEND THROUGH ROOF, BELOW PARAPET LEVEL

H

---

DJ

HOOKER | DE JONG  
 Architects & Engineers  
 316 Morris Avenue  
 Studio Suite 410  
 Muskegon, MI 49440  
 P 231 | 722 | 3407  
 F 231 | 722 | 2589

MULTI-FAMILY HOUSING  
 THE MEADOWLANDS  
 MADISON, WI  
 KGC HOUSING DEVELOPMENT

Project Number		<b>4-1125</b>
ISSUANCE		
No.	Date	Description
1	2019.05.28	SITE PLAN REVIEW

NOT FOR CONSTRUCTION

Copyright © 2019 HDJ Inc. All Rights Reserved

EXTERIOR ELEVATIONS

A4.3

**ELEVATION KEYNOTES**

1. HORIZONTAL FIBER CEMENT SIDING - COLOR 1
2. HORIZONTAL FIBER CEMENT SIDING - COLOR 2
3. FIBER CEMENT PANEL
4. FIBER CEMENT TRIM
5. STONE VENEER
6. CAST STONE SILL
7. VINYL WINDOW WITH FIBER CEMENT TRIM
8. FIBERGLASS DOOR
9. BALCONY CANOPY COLUMN WITH STONE VENEER
10. BALCONY CANOPY COLUMN WITH FIBER CEMENT WRAP
11. FIBER CEMENT FASCIA
12. MECHANICAL UNIT
13. DECORATIVE LIGHT FIXTURE
14. COMPOSITE CORBEL
15. BALCONY STRUCTURE WITH FIBER CEMENT TRIM
16. PAINTED METAL GUARDRAIL
17. ALUMINUM STOREFRONT SYSTEM
18. BUILDING SIGNAGE
19. ALUMINUM GUTTER AND DOWNSPOUTS
20. MECHANICAL PENETRATION
21. ASPHALT SHINGLES
22. INSULATED GARAGE DOOR

**GENERAL ELEVATION NOTES**

1. MECHANICAL PENETRATIONS AT 3 AND 4 STORY BUILDINGS TO EXTEND THROUGH ROOF, BELOW PARAPET LEVEL

H

DJ

HOOKER | DE JONG  
Architects & Engineers  
316 Morris Avenue  
Studio Suite 410  
Muskegon, MI 49440  
P 231 | 722 | 3407  
F 231 | 722 | 2589

MULTI-FAMILY HOUSING  
**THE MEADOWLANDS**  
MADISON, WI  
KGC HOUSING DEVELOPMENT

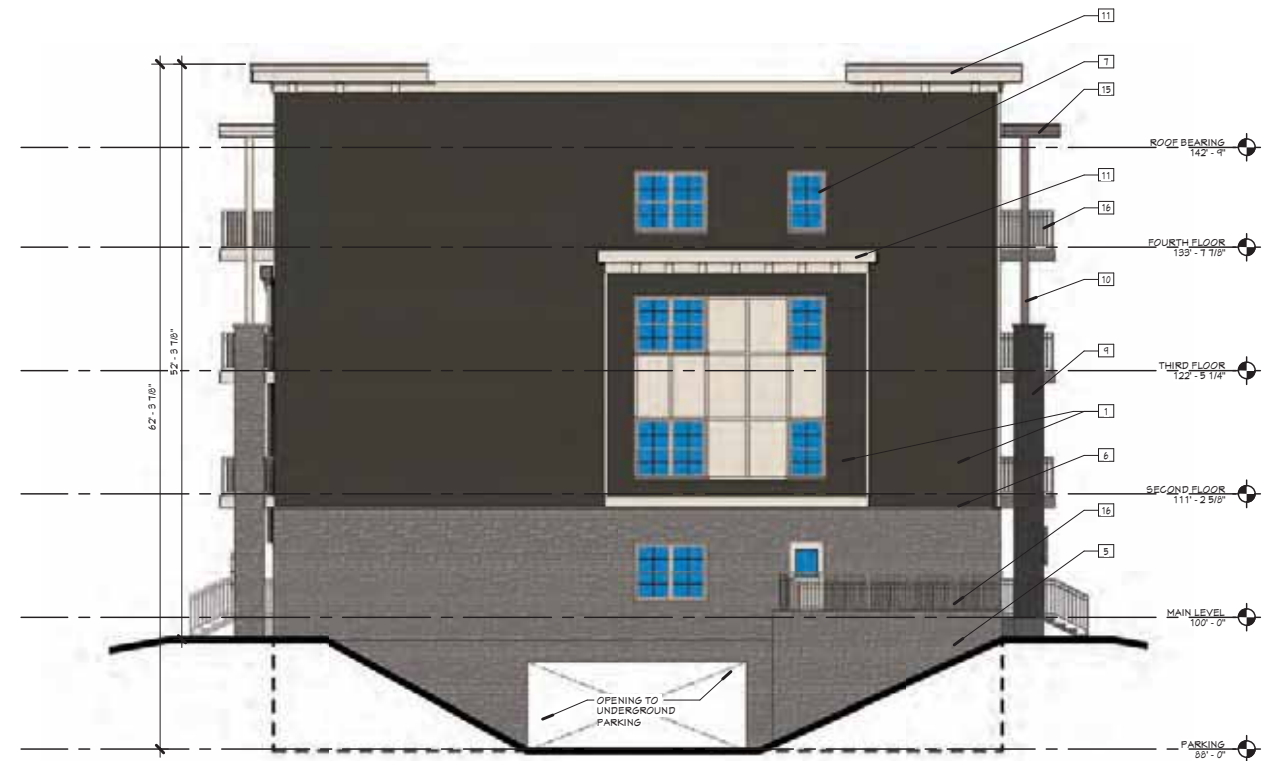

**1 BUILDING 3 - SOUTH ELEVATION**  
A4.4 1/8" = 1'-0"



**2 BUILDING 3 - WEST ELEVATION**  
A4.4 1/8" = 1'-0"

Project Number	4-1125	
ISSUANCE	No.	Date
	1	2019.05.28
	Description	
	SITE PLAN REVIEW	

NOT FOR CONSTRUCTION

Copyright © 2019 HDJ Inc. All Rights Reserved

EXTERIOR ELEVATIONS

A4.4

H

---

DJ

HOOKER | DE JONG  
Architects & Engineers  
316 Morris Avenue  
Studio Suite 410  
Muskegon, MI 49440  
P 231 722 1307  
F 231 722 1250

MULTI-FAMILY HOUSING  
THE MEADOWLANDS  
MADISON, WI

KGC HOUSING DEVELOPMENT

Project Number		4-1125
ISSUANCE		
No.	Date	Description
1	2019.05.28	SITE PLAN REVIEW

NOT FOR CONSTRUCTION

Copyright © 2019 HDJ Inc. All Rights Reserved.

EXTERIOR ELEVATIONS

A4.5

**ELEVATION KEYNOTES**

1. HORIZONTAL FIBER CEMENT SIDING - COLOR 1
2. HORIZONTAL FIBER CEMENT SIDING - COLOR 2
3. FIBER CEMENT PANEL
4. FIBER CEMENT TRIM
5. STONE VENEER
6. CAST STONE SILL
7. VINYL WINDOW WITH FIBER CEMENT TRIM
8. FIBERGLASS DOOR
9. BALCONY CANOPY COLUMN WITH STONE VENEER
10. BALCONY CANOPY COLUMN WITH FIBER CEMENT WRAP
11. FIBER CEMENT FASCIA
12. MECHANICAL UNIT
13. DECORATIVE LIGHT FIXTURE
14. COMPOSITE CORSEL
15. BALCONY STRUCTURE WITH FIBER CEMENT TRIM
16. PAINTED METAL GUARDRAIL
17. ALUMINUM STOREFRONT SYSTEM
18. BUILDING SIGNAGE
19. ALUMINUM GUTTER AND DOWNSPOUTS
20. MECHANICAL PENETRATION
21. ASPHALT SHINGLES
22. INSULATED GARAGE DOOR

**GENERAL ELEVATION NOTES**

1. MECHANICAL PENETRATIONS AT 3 AND 4 STORY BUILDINGS TO EXTEND THROUGH ROOF, BELOW PARAPET LEVEL

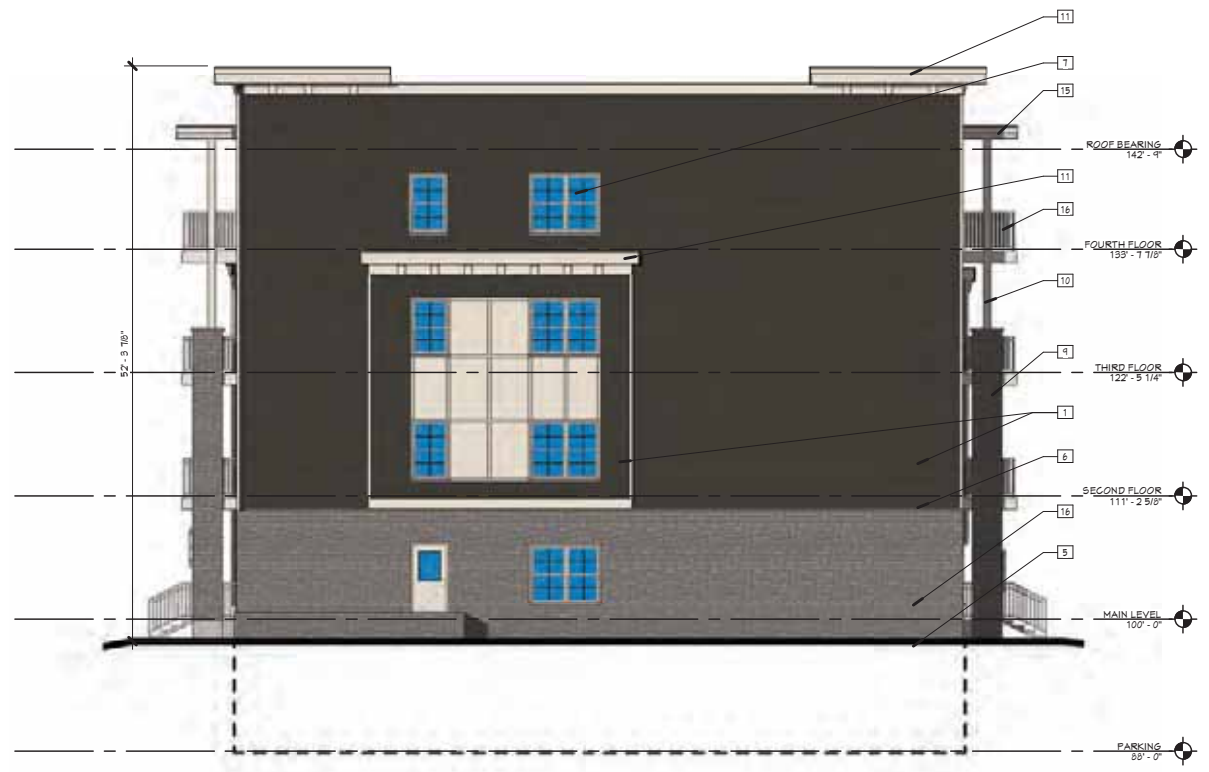

2 BUILDING 3 - NORTH ELEVATION  
A4.5 1/8" = 1'-0"



1 BUILDING 3 - EAST ELEVATION  
A4.5 1/8" = 1'-0"



**ELEVATION KEYNOTES**

1. HORIZONTAL FIBER CEMENT SIDING - COLOR 1
2. HORIZONTAL FIBER CEMENT SIDING - COLOR 2
3. FIBER CEMENT PANEL
4. FIBER CEMENT TRIM
5. STONE VENEER
6. CAST STONE SILL
7. VINYL WINDOW WITH FIBER CEMENT TRIM
8. FIBERGLASS DOOR
9. BALCONY CANOPY COLUMN WITH STONE VENEER
10. BALCONY CANOPY COLUMN WITH FIBER CEMENT WRAP
11. FIBER CEMENT FASCIA
12. MECHANICAL UNIT
13. DECORATIVE LIGHT FIXTURE
14. COMPOSITE CORBEL
15. BALCONY STRUCTURE WITH FIBER CEMENT TRIM
16. PAINTED METAL GUARDRAIL
17. ALUMINUM STOREFRONT SYSTEM
18. BUILDING SIGNAGE
19. ALUMINUM GUTTER AND DOWNSPOUTS
20. MECHANICAL PENETRATION
21. ASPHALT SHINGLES
22. INSULATED GARAGE DOOR

**GENERAL ELEVATION NOTES**

1. MECHANICAL PENETRATIONS AT 3 AND 4 STORY BUILDINGS TO EXTEND THROUGH ROOF, BELOW PARAPET LEVEL

H

DJ

HOOKER | DE JONG  
Architects & Engineers  
318 Morris Avenue  
Studio Suite 410  
Muskegon, MI 49440  
P 231.722.1307  
F 231.722.1250

MULTI-FAMILY HOUSING  
**THE MEADOWLANDS**  
MADISON, WI  
KGC HOUSING DEVELOPMENT

Project Number **4-1125**

ISSUANCE		
No.	Date	Description
1	2019.05.28	SITE PLAN REVIEW

NOT FOR CONSTRUCTION

Copyright © 2019 HDJ Inc. All Rights Reserved

EXTERIOR ELEVATIONS

**A4.6**



**3 BUILDING 4 - NORTH ELEVATION**  
A4.6 1/8" = 1'-0"



**2 BUILDING 4 - WEST ELEVATION**  
A4.6 1/8" = 1'-0"



**1 BUILDING 4 - SOUTH ELEVATION**  
A4.6 1/8" = 1'-0"

H

DJ

HOOKER | DE JONG  
Architects & Engineers  
316 Morris Avenue  
Studio Suite 410  
Muskegon, MI 49440  
P 231 | 722 | 3407  
F 231 | 722 | 2589

MULTI-FAMILY HOUSING  
THE MEADOWLANDS  
MADISON, WI

KGC HOUSING DEVELOPMENT

Project Number **4-1125**

ISSUANCE		
No.	Date	Description
1	2019.05.28	SITE PLAN REVIEW

NOT FOR  
CONSTRUCTION

Copyright © 2019 HDJ Inc. All Rights Reserved.

EXTERIOR  
ELEVATIONS

A4.7

**ELEVATION KEYNOTES**

1. HORIZONTAL FIBER CEMENT SIDING - COLOR 1
2. HORIZONTAL FIBER CEMENT SIDING - COLOR 2
3. FIBER CEMENT PANEL
4. FIBER CEMENT TRIM
5. STONE VENEER
6. CAST STONE SILL
7. VINYL WINDOW WITH FIBER CEMENT TRIM
8. FIBERGLASS DOOR
9. BALCONY CANOPY COLUMN WITH STONE VENEER
10. BALCONY CANOPY COLUMN WITH FIBER CEMENT WRAP
11. FIBER CEMENT FASCIA
12. MECHANICAL UNIT
13. DECORATIVE LIGHT FIXTURE
14. COMPOSITE CORSEL
15. BALCONY STRUCTURE WITH FIBER CEMENT TRIM
16. PAINTED METAL GUARDRAIL
17. ALUMINUM STOREFRONT SYSTEM
18. BUILDING SIGNAGE
19. ALUMINUM GUTTER AND DOWNSPOUTS
20. MECHANICAL PENETRATION
21. ASPHALT SHINGLES
22. INSULATED GARAGE DOOR

**GENERAL  
ELEVATION NOTES**

1. MECHANICAL PENETRATIONS AT 3 AND 4 STORY BUILDINGS TO EXTEND THROUGH ROOF, BELOW PARAPET LEVEL



2  
A4.7 **BUILDING 4 - NORTHWEST ELEVATION**  
1/8" = 1'-0"



1  
A4.7 **BUILDING 4 - SOUTHWEST ELEVATION**  
1/8" = 1'-0"

H

DJ

HOOKER | DE JONG  
Architects & Engineers  
316 Morris Avenue  
Studio Suite 410  
Muskegon, MI 49440  
P 231 / 722 / 3407  
F 231 / 722 / 2589

MULTI-FAMILY HOUSING  
**THE MEADOWLANDS**  
MADISON, WI  
KGC HOUSING DEVELOPMENT

Project Number **4-1125**

ISSUANCE		
No.	Date	Description
1	2019.05.28	SITE PLAN REVIEW

NOT FOR CONSTRUCTION

Copyright © 2019 HDJ Inc. All Rights Reserved

EXTERIOR ELEVATIONS

**A4.8**

**ELEVATION KEYNOTES**

1. HORIZONTAL FIBER CEMENT SIDING - COLOR 1
2. HORIZONTAL FIBER CEMENT SIDING - COLOR 2
3. FIBER CEMENT PANEL
4. FIBER CEMENT TRIM
5. STONE VENEER
6. CAST STONE SILL
7. VINYL WINDOW WITH FIBER CEMENT TRIM
8. FIBERGLASS DOOR
9. BALCONY CANOPY COLUMN WITH STONE VENEER
10. BALCONY CANOPY COLUMN WITH FIBER CEMENT WRAP
11. FIBER CEMENT FASCIA
12. MECHANICAL UNIT
13. DECORATIVE LIGHT FIXTURE
14. COMPOSITE CORBEL
15. BALCONY STRUCTURE WITH FIBER CEMENT TRIM
16. PAINTED METAL GUARDRAIL
17. ALUMINUM STOREFRONT SYSTEM
18. BUILDING SIGNAGE
19. ALUMINUM GUTTER AND DOWNSPOUTS
20. MECHANICAL PENETRATION
21. ASPHALT SHINGLES
22. INSULATED GARAGE DOOR

**GENERAL ELEVATION NOTES**

1. MECHANICAL PENETRATIONS AT 3 AND 4 STORY BUILDINGS TO EXTEND THROUGH ROOF, BELOW PARAPET LEVEL



**2**  
A4.8 **BUILDING 4 - EAST ELEVATION**  
1/8" = 1'-0"



**1**  
A4.8 **BUILDING 4 - NORTHEAST ELEVATION**  
1/8" = 1'-0"

5/28/2019 2:08:16 PM  
C:\I-Revit\Projects\4-1125 - ARCH - exterior\Recovery.rvt

**ELEVATION KEYNOTES**

1. HORIZONTAL FIBER CEMENT SIDING - COLOR 1
2. HORIZONTAL FIBER CEMENT SIDING - COLOR 2
3. FIBER CEMENT PANEL
4. FIBER CEMENT TRIM
5. STONE VENEER
6. CAST STONE SILL
7. VINYL WINDOW WITH FIBER CEMENT TRIM
8. FIBERGLASS DOOR
9. BALCONY CANOPY COLUMN WITH STONE VENEER
10. BALCONY CANOPY COLUMN WITH FIBER CEMENT WRAP
11. FIBER CEMENT FASCIA
12. MECHANICAL UNIT
13. DECORATIVE LIGHT FIXTURE
14. COMPOSITE CORBEL
15. BALCONY STRUCTURE WITH FIBER CEMENT TRIM
16. PAINTED METAL GUARDRAIL
17. ALUMINUM STOREFRONT SYSTEM
18. BUILDING SIGNAGE
19. ALUMINUM GUTTER AND DOWNSPOUTS
20. MECHANICAL PENETRATION
21. ASPHALT SHINGLES
22. INSULATED GARAGE DOOR

**GENERAL ELEVATION NOTES**

1. MECHANICAL PENETRATIONS AT 3 AND 4 STORY BUILDINGS TO EXTEND THROUGH ROOF, BELOW PARAPET LEVEL

H

DJ

HOOKER | DE JONG  
Architects & Engineers  
316 Morris Avenue  
Studio Suite 410  
Muskegon, MI 49440  
P 231 / 722 / 3407  
F 231 / 722 / 2589

MULTI-FAMILY HOUSING  
**THE MEADOWLANDS**  
MADISON, WI  
KGC HOUSING DEVELOPMENT

Project Number **4-1125**

ISSUANCE		
No.	Date	Description
1	2019.05.28	SITE PLAN REVIEW

NOT FOR CONSTRUCTION

Copyright © 2019 HDJ Inc. All Rights Reserved

EXTERIOR ELEVATIONS

**A4.9**



**4 BUILDING 5 - EAST ELEVATION**  
A4.9 1/8" = 1'-0"



**3 BUILDING 5 - NORTH ELEVATION**  
A4.9 1/8" = 1'-0"



**2 BUILDING 5 - SOUTH ELEVATION**  
A4.9 1/8" = 1'-0"



**1 BUILDING 5 - WEST ELEVATION**  
A4.9 1/8" = 1'-0"



VIEW DOWN WIND STONE DRIVE



VIEW ALONG MILWAUKEE AVE



VIEW FROM PARKING LOT



VIEW FROM MILWAUKEE AVE



VIEW ALONG WIND STONE



VIEW FROM MILWAUKEE AVE



VIEW FROM CORNER OF MILWAUKEE AND WIND STONE





VIEW ALONG WIND STONE