



740 REGENT STREET

MADISON, WI

CONCEPT DESIGN

MARCH 9TH, 2022

AERIAL VIEW | CONTEXT



LEGEND

- RESIDENTIAL + RETAIL
- SPORTS ARENA
- OFFICE + INSTITUTIONAL
- RETAIL/COMMERCIAL
- HEALTH CARE
- HOTEL
- SCHOOL

EXISTING SITE PHOTOS



EXISTING SITE PHOTOS



EXISTING SITE PHOTOS | COMMUTER PATH



EXISTING SITE PHOTOS | COMMUTER PATH



EXISTING SITE PHOTOS | COMMUTER PATH





- OF APPROXIMATELY 2 ACRES OF PROJECT DISTURBANCE, 0.4 ACRES OR APPROXIMATELY 20% IS CITY OWNED REAL ESTATE OF WHICH **70% IS BEING CONVERTED TO LANDSCAPING**, A SIGNIFICANT INCREASE FROM THE CURRENT CONDITION OF 10% LANDSCAPING
- STORMWATER DETENTION REDUCES FLOODING AND EROSION DOWNSTREAM
- SOLVING EXISTING **BROWNFIELD SITE** WITH REMEDIATION AND **DEVELOPER INVESTMENT IN EXCESS OF \$500,000**

BUILDING BACK SMART & SUSTAINABLE = SITE DEVELOPMENT THAT SOLVES FOR MULTIPLE PARKING USES (CURRENT + FUTURE) IN ONE STRUCTURE, WITHOUT VISIBLE PARKING AT GRADE, AND THE CONVERSION OF SURFACE PARKING TO GREEN SPACE:

- HOTEL PARKING
- 700 + 740 REGENT STREET OFFICE BUILDINGS
- KOHL CENTER EVENTS
- RESIDENTIAL PARKING

CONNECTIVITY & SITE CIRCULATION MAP

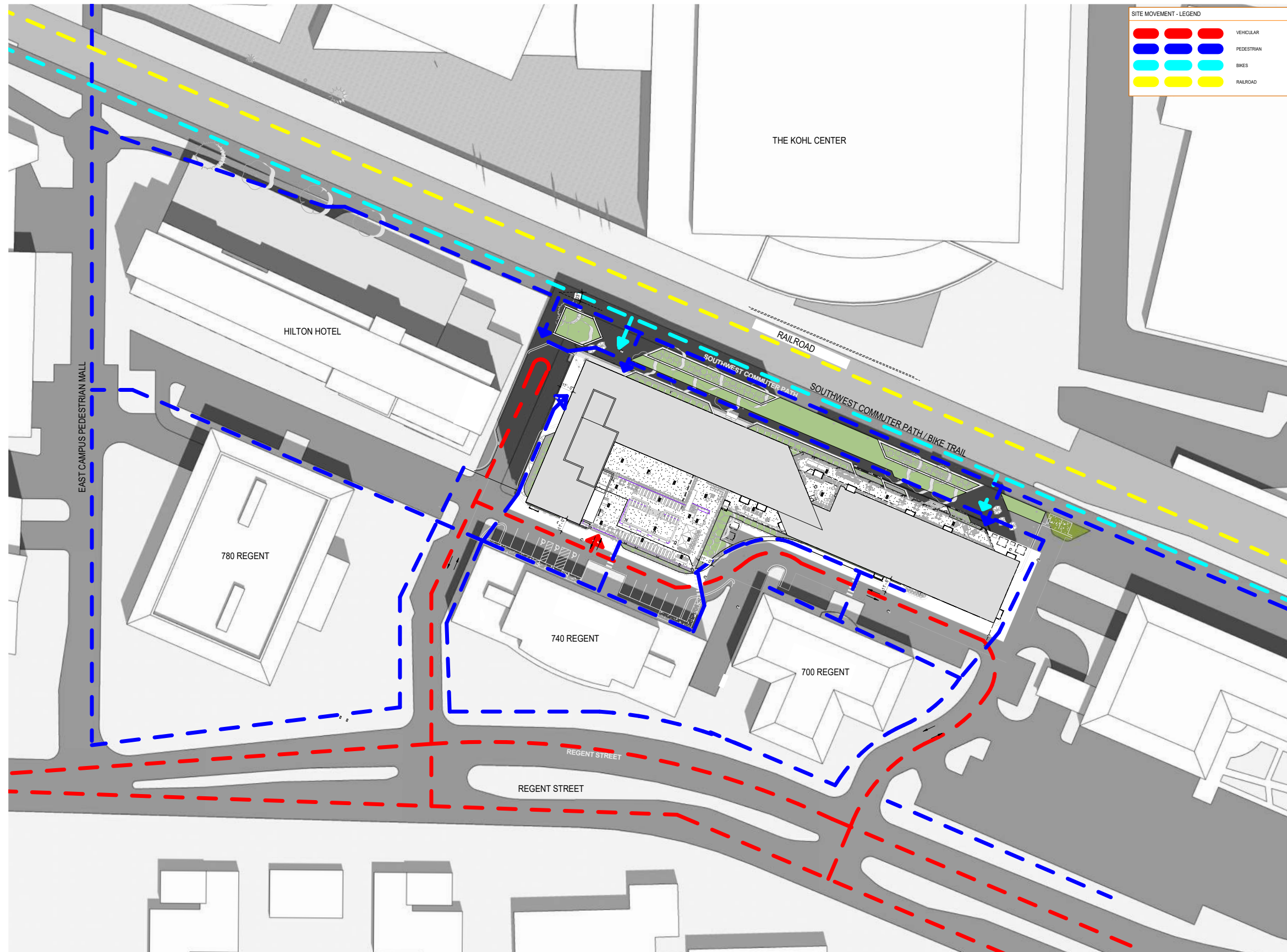

SITE PLAN

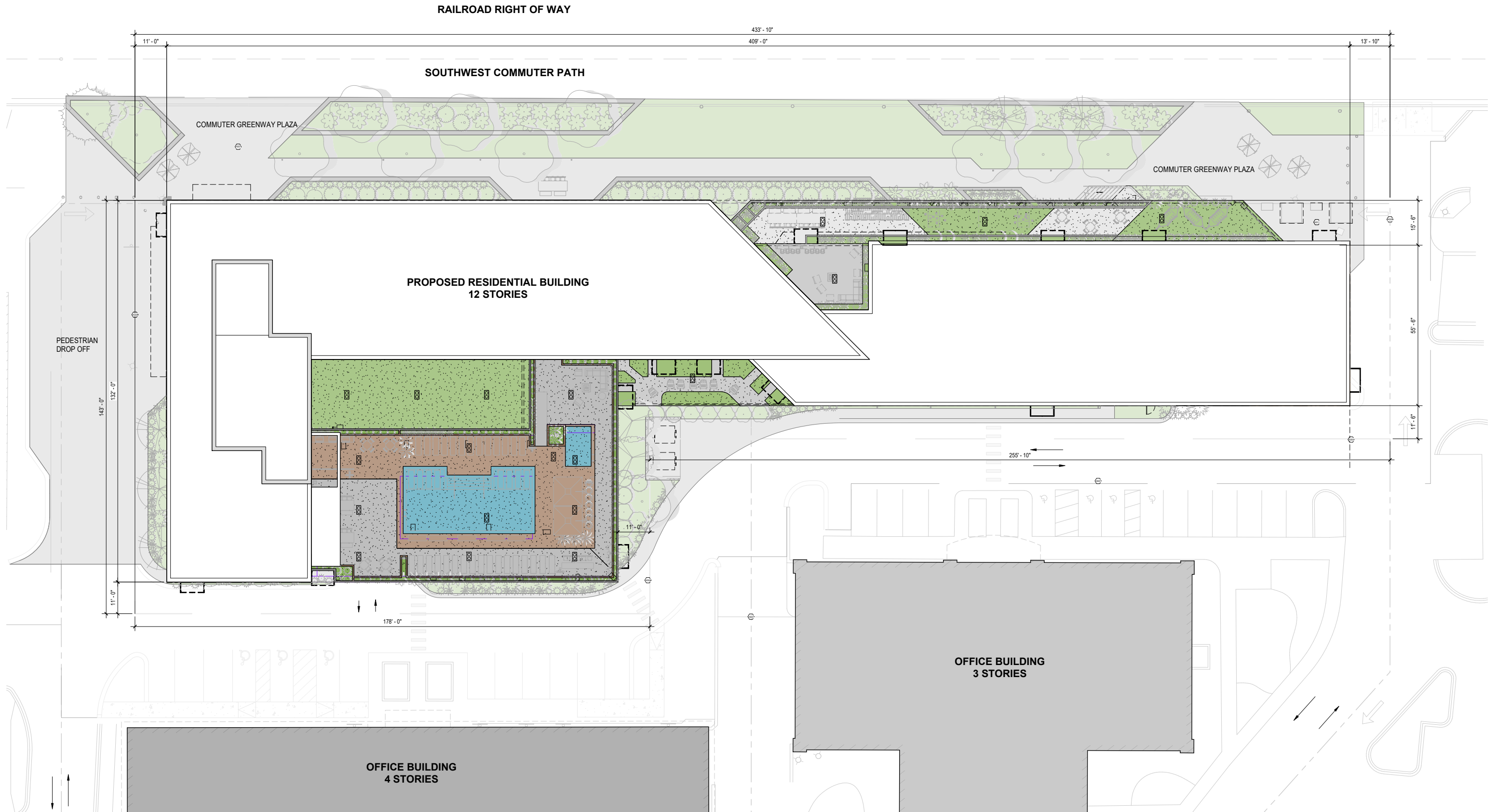

PERSPECTIVES | NORTH AERIAL VIEW



NOTE | ALL BUILDING SIGNAGE LOCATIONS SHOWN AS DRAFT

PERSPECTIVES | SOUTH AERIAL VIEW



NOTE | ALL BUILDING SIGNAGE LOCATIONS SHOWN AS DRAFT



NOTE | ALL BUILDING SIGNAGE LOCATIONS SHOWN AS DRAFT



NOTE | ALL BUILDING SIGNAGE LOCATIONS SHOWN AS DRAFT



NOTE | ALL BUILDING SIGNAGE LOCATIONS SHOWN AS DRAFT



Office Parking
Structure Entry

S
I
G
N
A
G
E

NOTE | ALL BUILDING SIGNAGE LOCATIONS SHOWN AS DRAFT

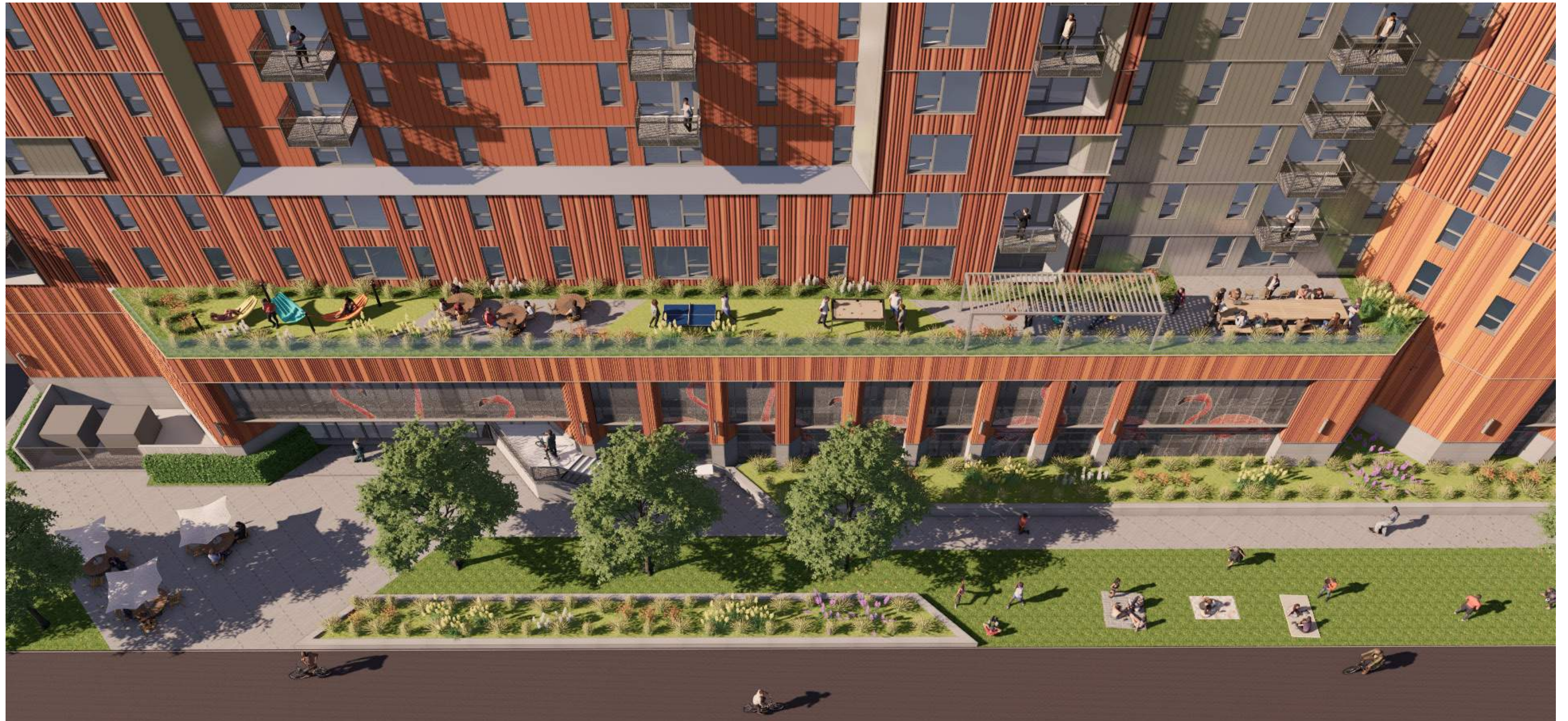

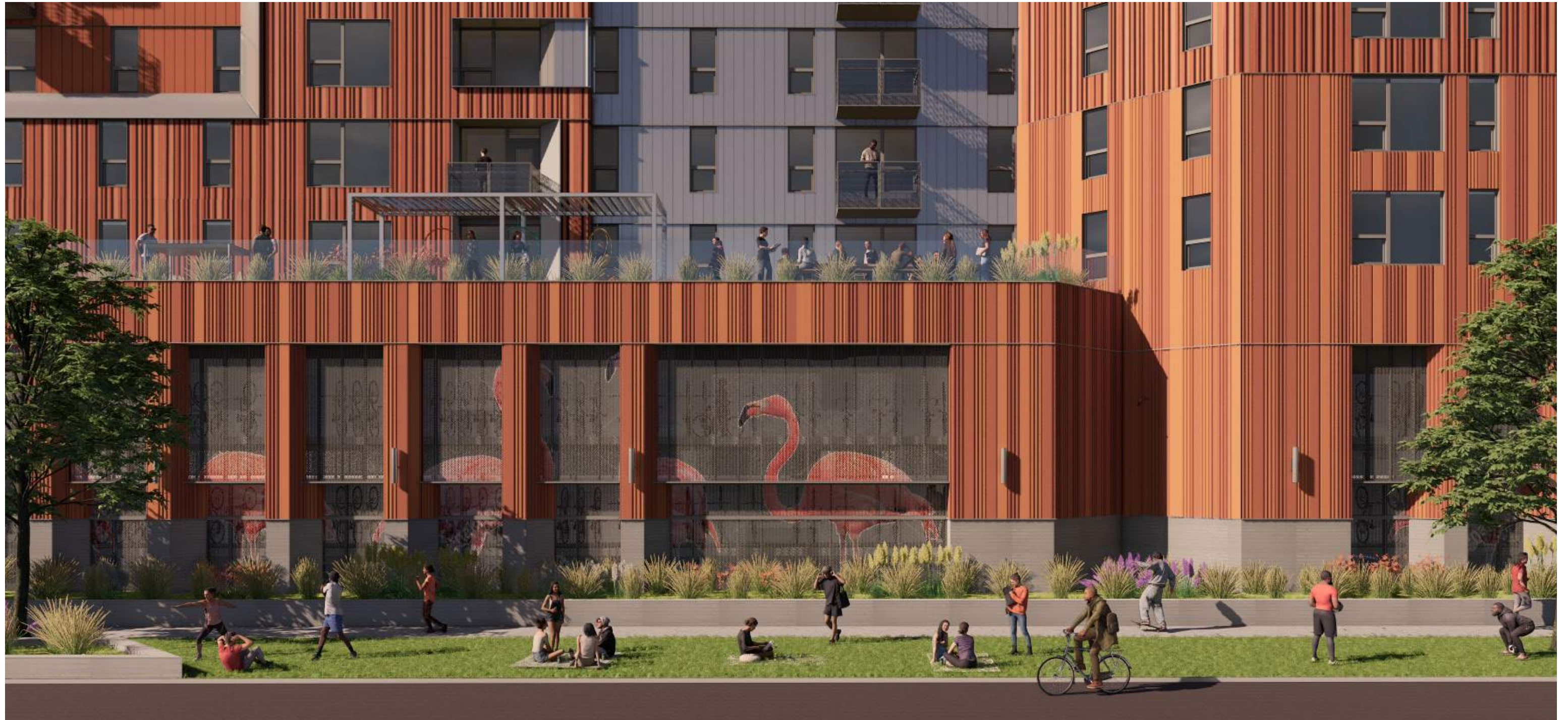

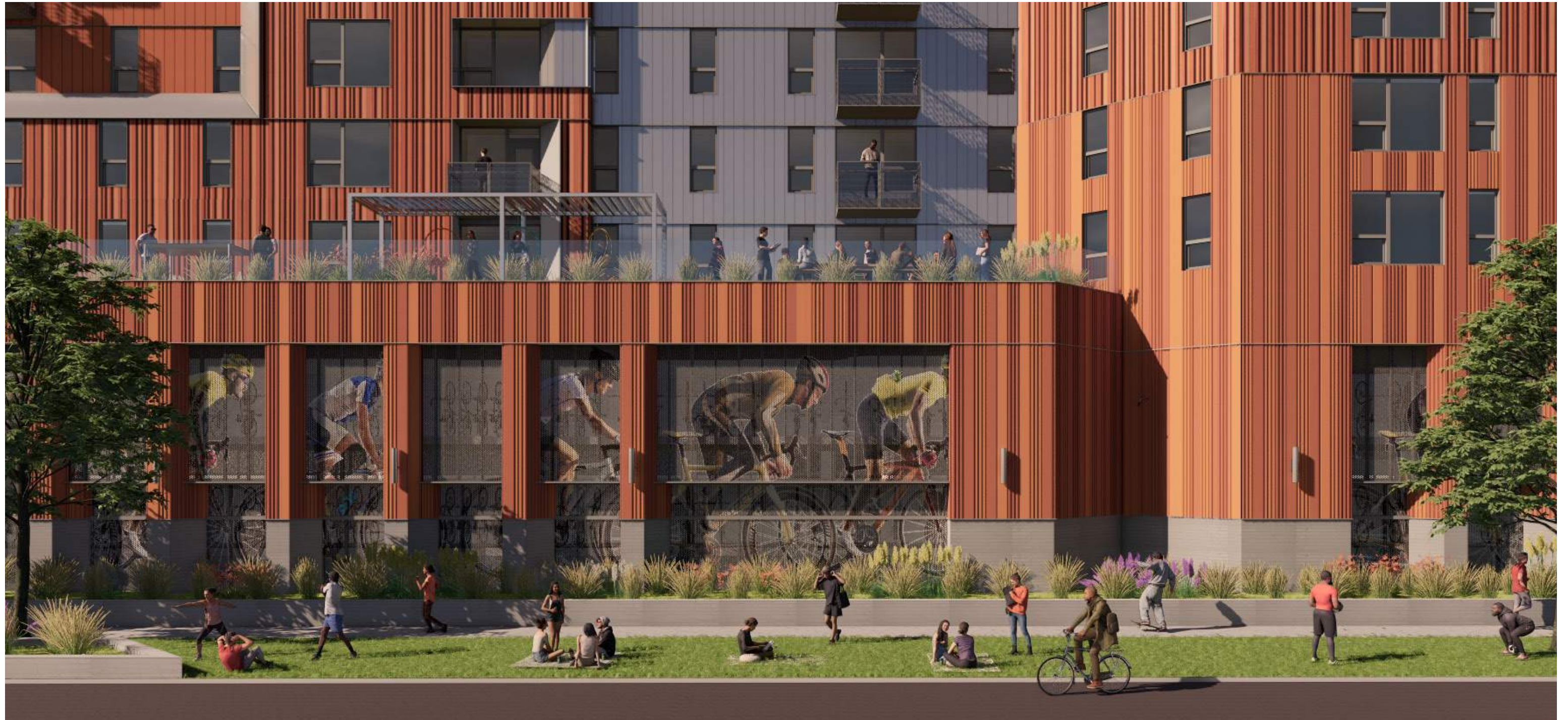



















VIGNETTES | PERFORATED METAL SCREEN

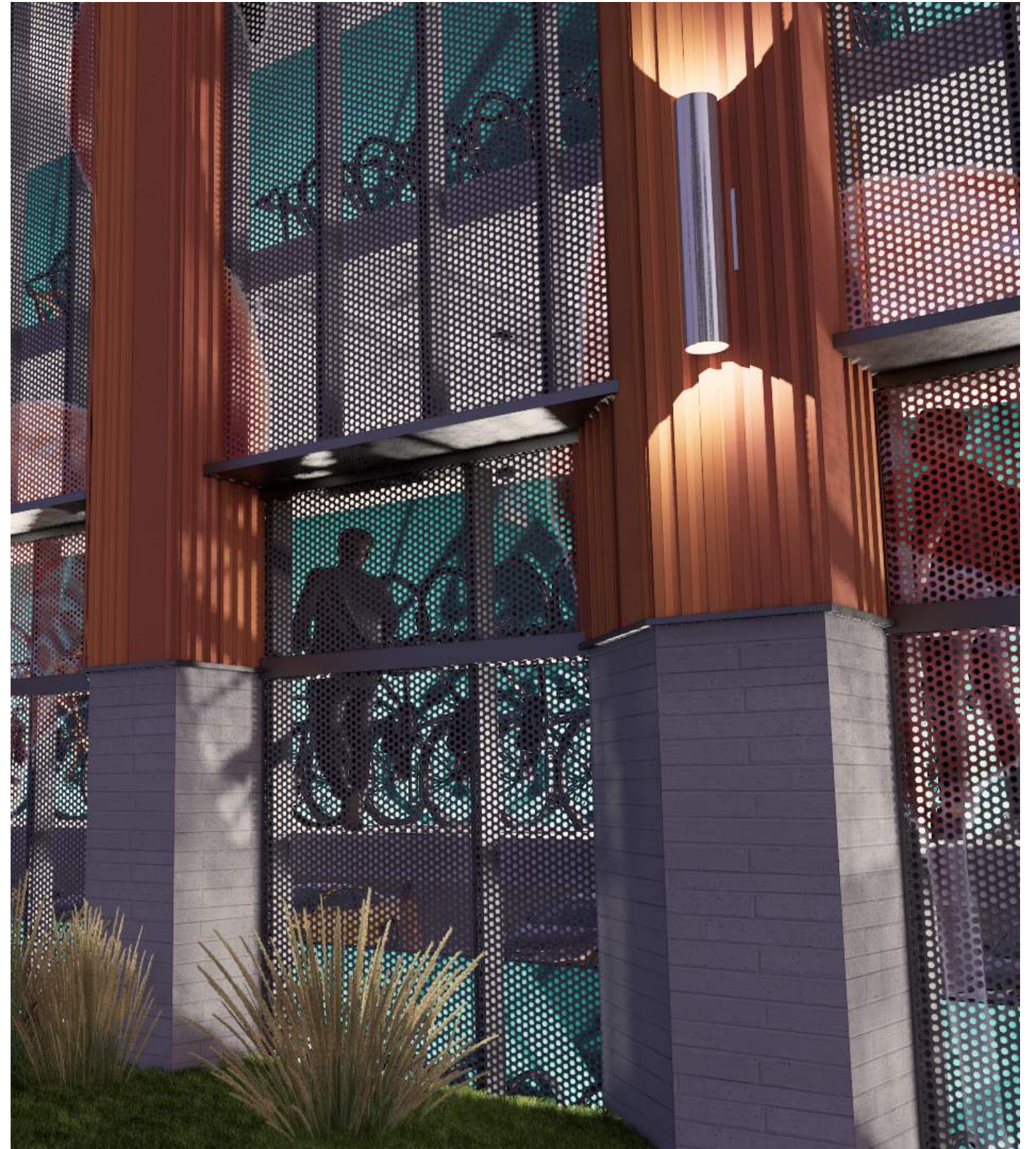







PROGRESSION | GROUND PLANE ACTIVATION

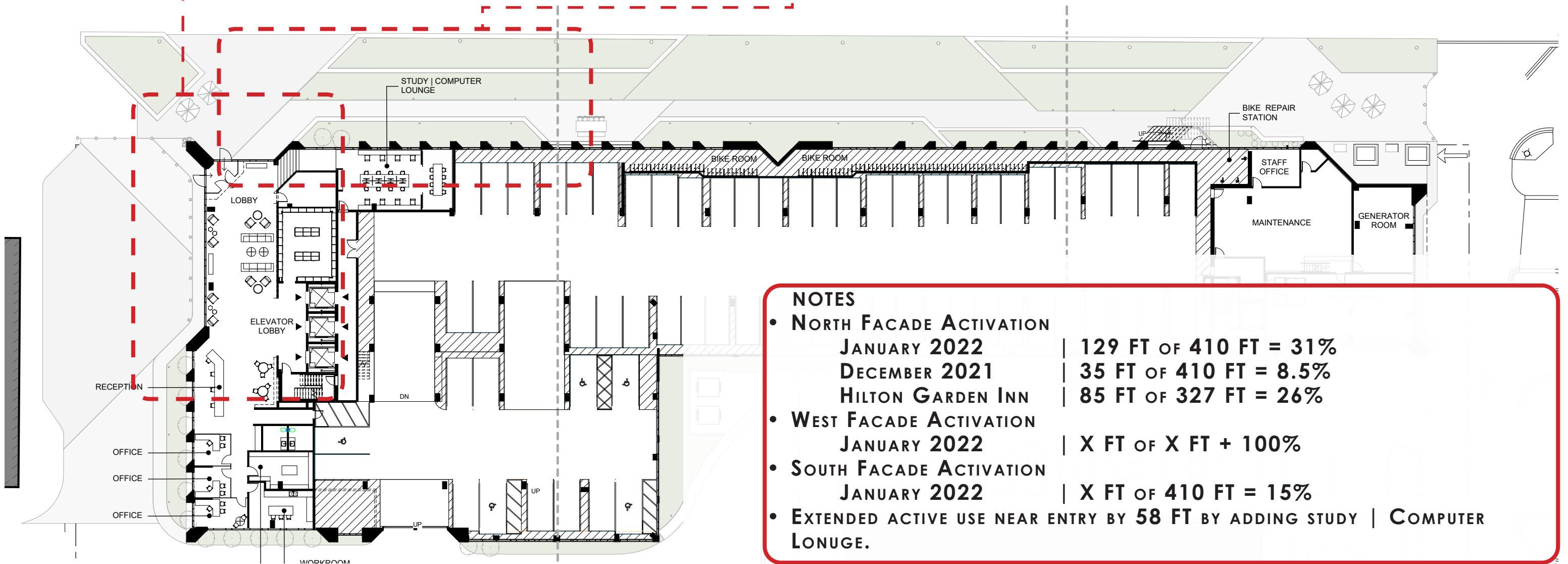

- NOTES**
- **NORTH FACADE ACTIVATION**
 JANUARY 2022 | 129 FT OF 410 FT = 31%
 DECEMBER 2021 | 35 FT OF 410 FT = 8.5%
 HILTON GARDEN INN | 85 FT OF 327 FT = 26%
 - **WEST FACADE ACTIVATION**
 JANUARY 2022 | X FT OF X FT + 100%
 - **SOUTH FACADE ACTIVATION**
 JANUARY 2022 | X FT OF 410 FT = 15%
 - **EXTENDED ACTIVE USE NEAR ENTRY BY 58 FT BY ADDING STUDY | COMPUTER LOUNGE.**

PROGRESSION | GROUND PLANE ACTIVATION

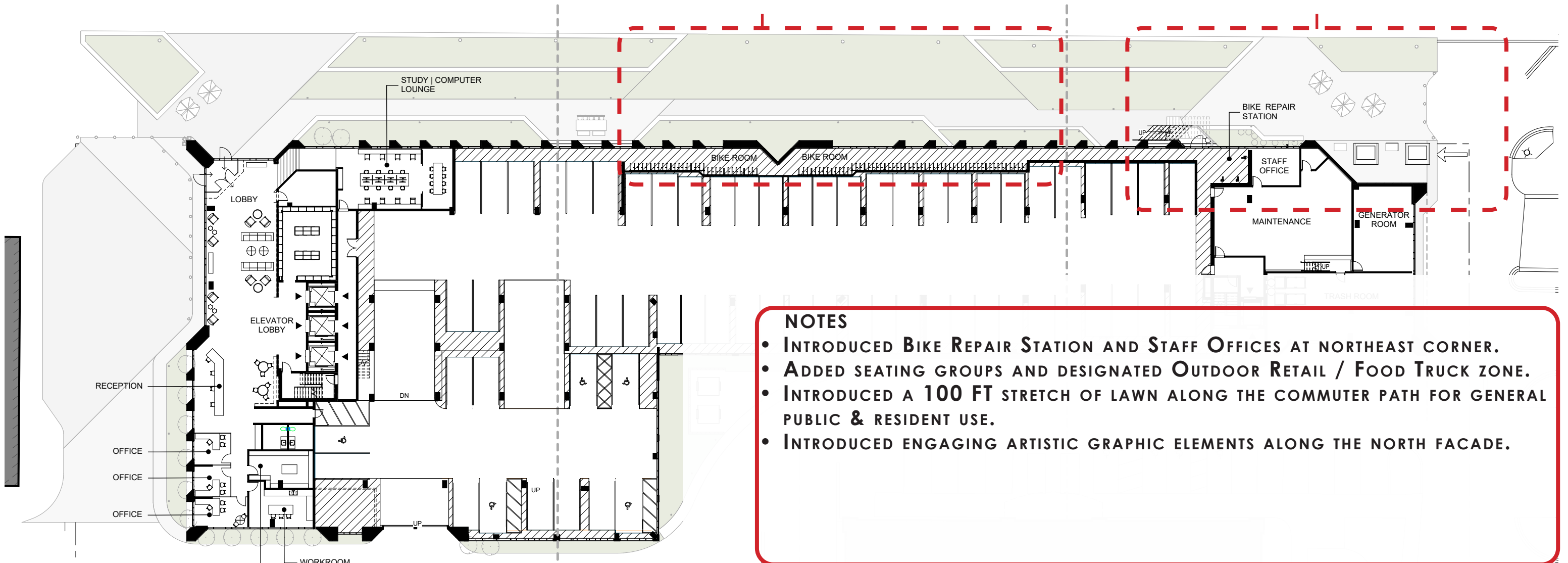

- NOTES**
- INTRODUCED BIKE REPAIR STATION AND STAFF OFFICES AT NORTHEAST CORNER.
 - ADDED SEATING GROUPS AND DESIGNATED OUTDOOR RETAIL / FOOD TRUCK ZONE.
 - INTRODUCED A 100 FT STRETCH OF LAWN ALONG THE COMMUTER PATH FOR GENERAL PUBLIC & RESIDENT USE.
 - INTRODUCED ENGAGING ARTISTIC GRAPHIC ELEMENTS ALONG THE NORTH FACADE.

INCREASED ACTIVATION + ARTICULATION | NORTH

FACADE MATERIALS

- MP-1 VERTICAL RIBBED METAL PANEL
- MP-3 ALUMINUM COMPOSITE PANEL
- ASF-1 ALUMINUM STOREFRONT (KAWNEER - SSG TYPE)
- MP-5 PERFORATED METAL PANEL SCREEN

- MP-2 VERTICAL REVEAL PANEL - TYPICAL RECESSED AREA & INSIDE COURTYARD
- W-1 FIBERGLASS WINDOW
- FBR-1 MASONRY
- MP-7 WIREMESH BALCONY RAILING SYSTEM

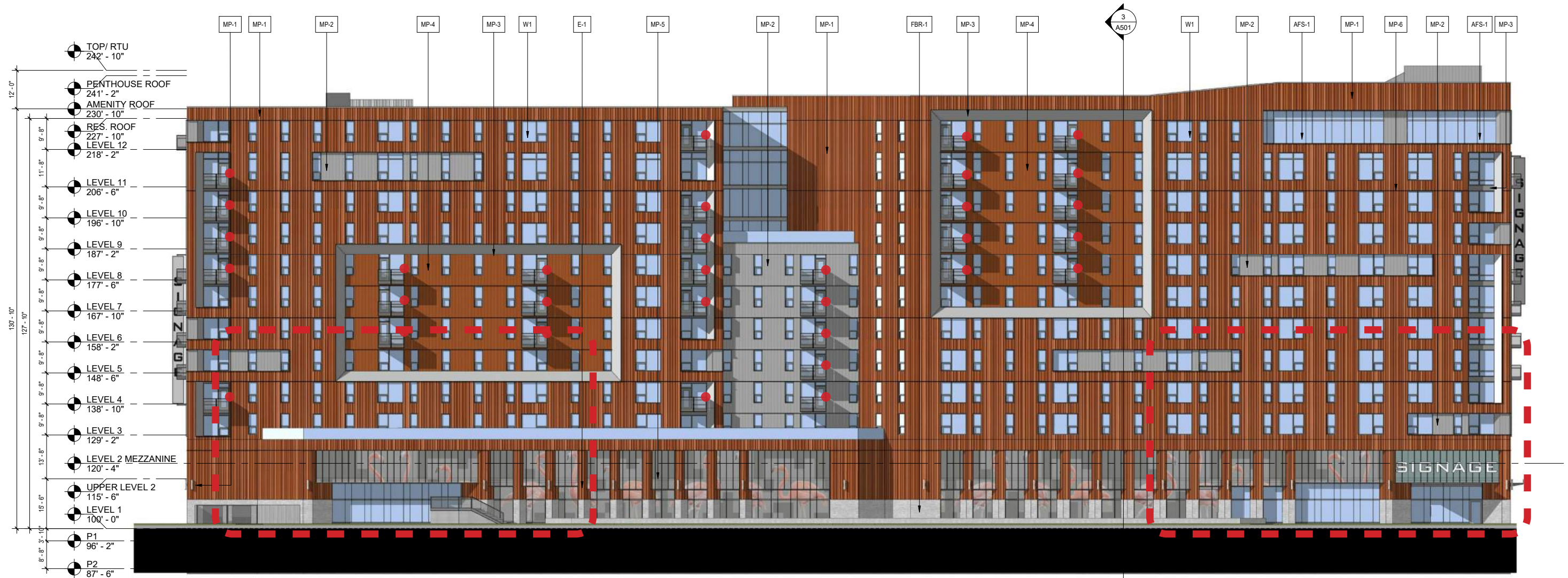

INCREASED ACTIVATION + ARTICULATION | EAST & WEST

FACADE MATERIALS

- MP-1 VERTICAL RIBBED METAL PANEL
- MP-3 ALUMINUM COMPOSITE PANEL
- ASF-1 ALUMINUM STOREFRONT (KAWNEER - SSG TYPE)
- MP-5 PERFORATED METAL PANEL SCREEN

- MP-2 VERTICAL REVEAL PANEL - TYPICAL RECESSED AREA & INSIDE COURTYARD
- W-1 FIBERGLASS WINDOW
- FBR-1 MASONRY
- MP-7 WIREMESH BALCONY RAILING SYSTEM

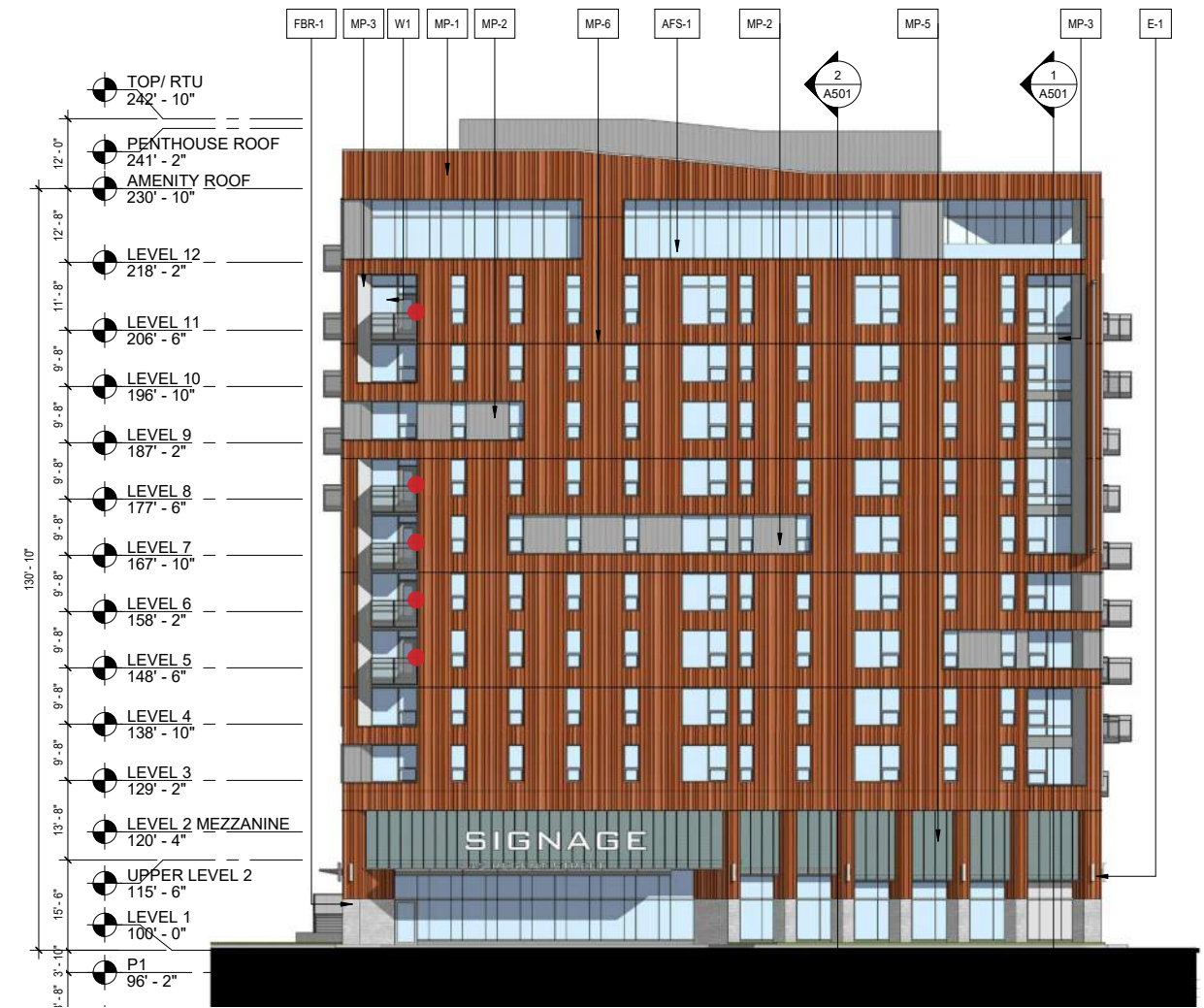

INCREASED ACTIVATION + ARTICULATION | SOUTH

FACADE MATERIALS

- MP-1 VERTICAL RIBBED METAL PANEL
- MP-3 ALUMINUM COMPOSITE PANEL
- ASF-1 ALUMINUM STOREFRONT (KAWNEER - SSG TYPE)
- MP-5 PERFORATED METAL PANEL SCREEN

- MP-2 VERTICAL REVEAL PANEL - TYPICAL RECESSED AREA & INSIDE COURTYARD
- W-1 FIBERGLASS WINDOW
- FBR-1 MASONRY
- MP-7 WIREMESH BALCONY RAILING SYSTEM



INCREASED ACTIVATION | NORTH ENLARGED



DECEMBER 2021



DECEMBER 2021



JANUARY 2022



JANUARY 2022

ARTICULATION PROGRESSION | BALCONIES





THE GREENWAY PLAZA

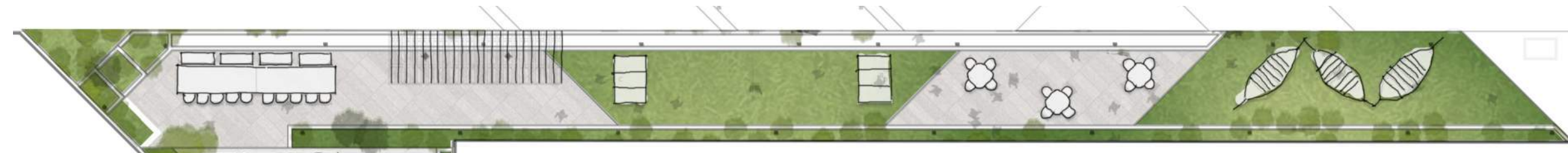

THE EDGE GREEN



THE PERCH



THE GAME & THEATER GARDEN



THE SKY DECK

THANK YOU!

REFERENCE MATERIALS

FLOOR PLANS | LEVEL 3

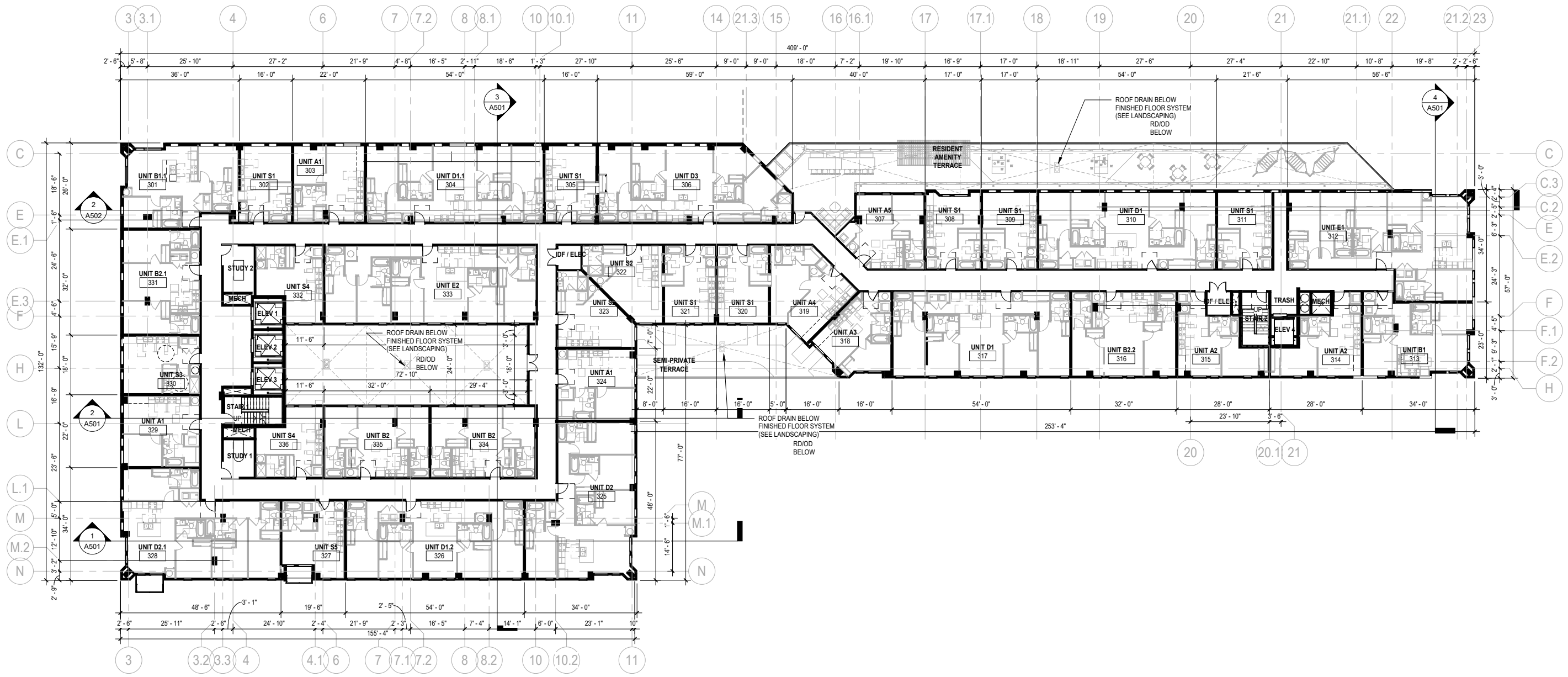

FLOOR PLANS | LEVELS 9-11

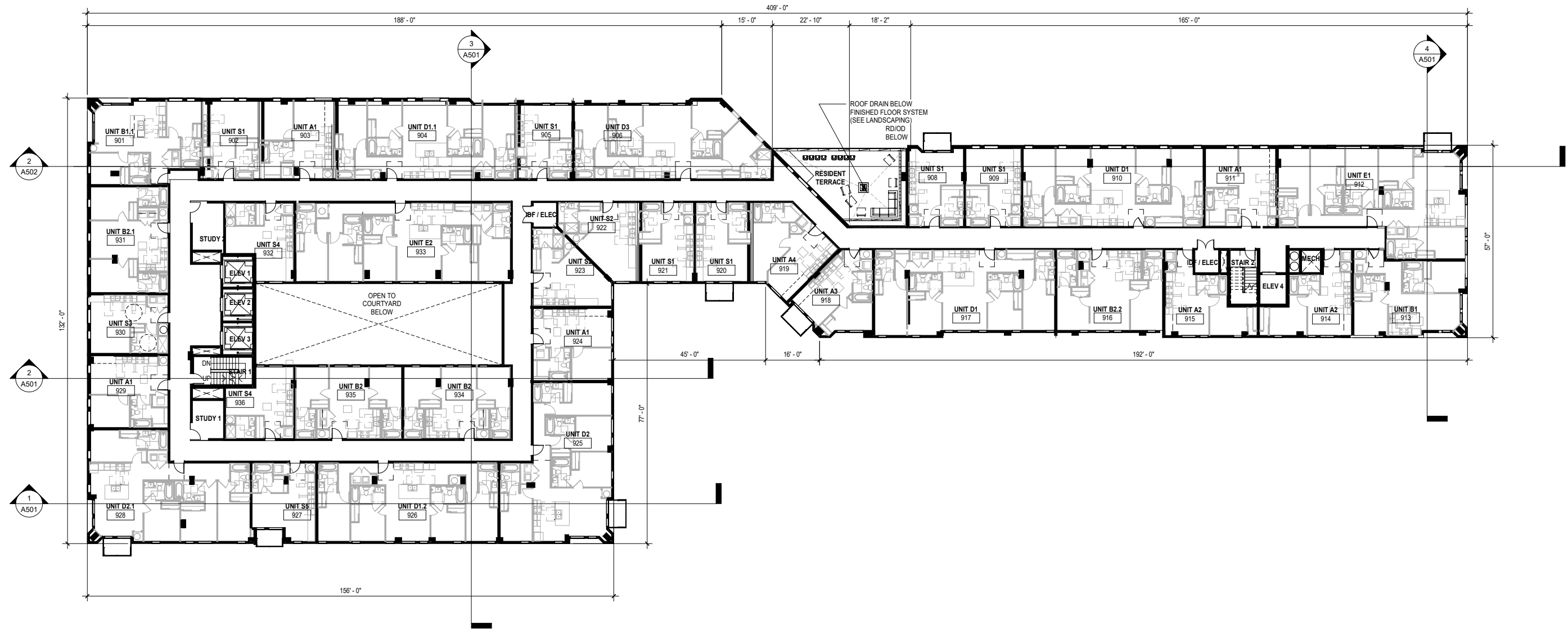

FLOOR PLANS | LEVEL 12

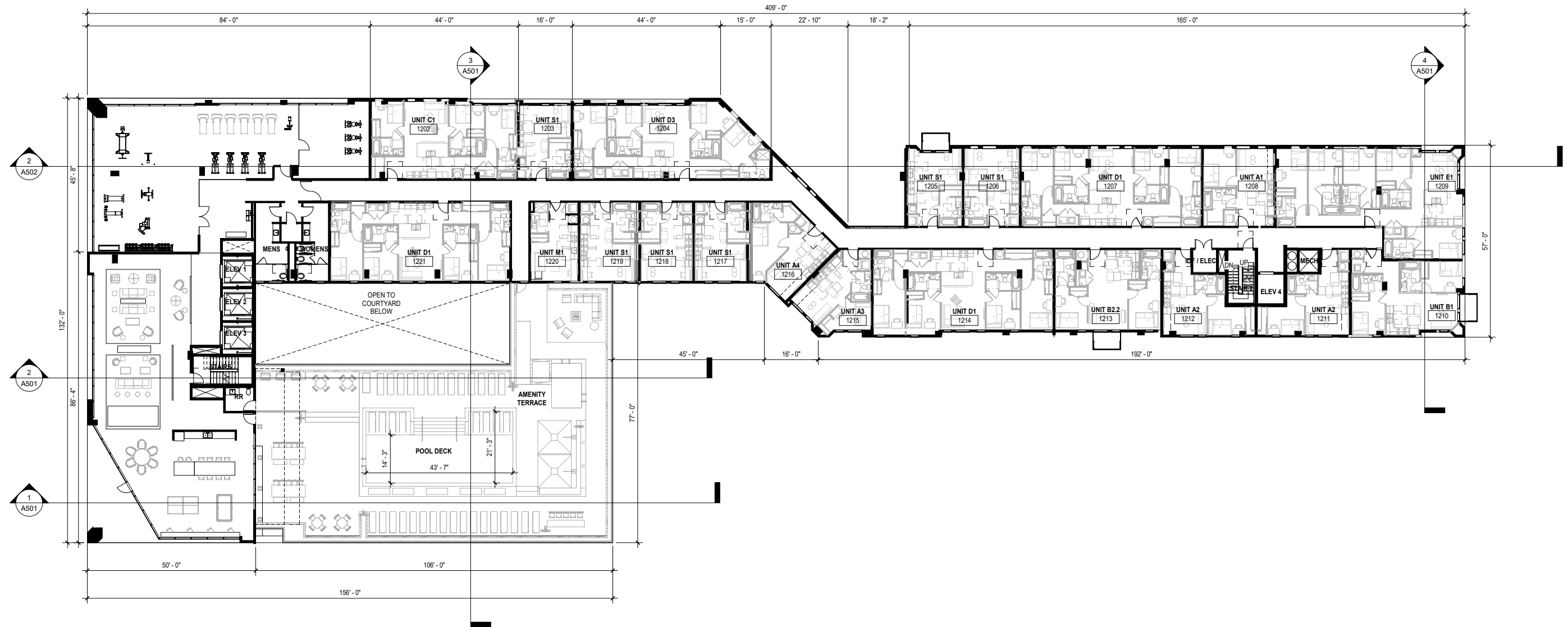

LANDSCAPE | PLANTING PLAN

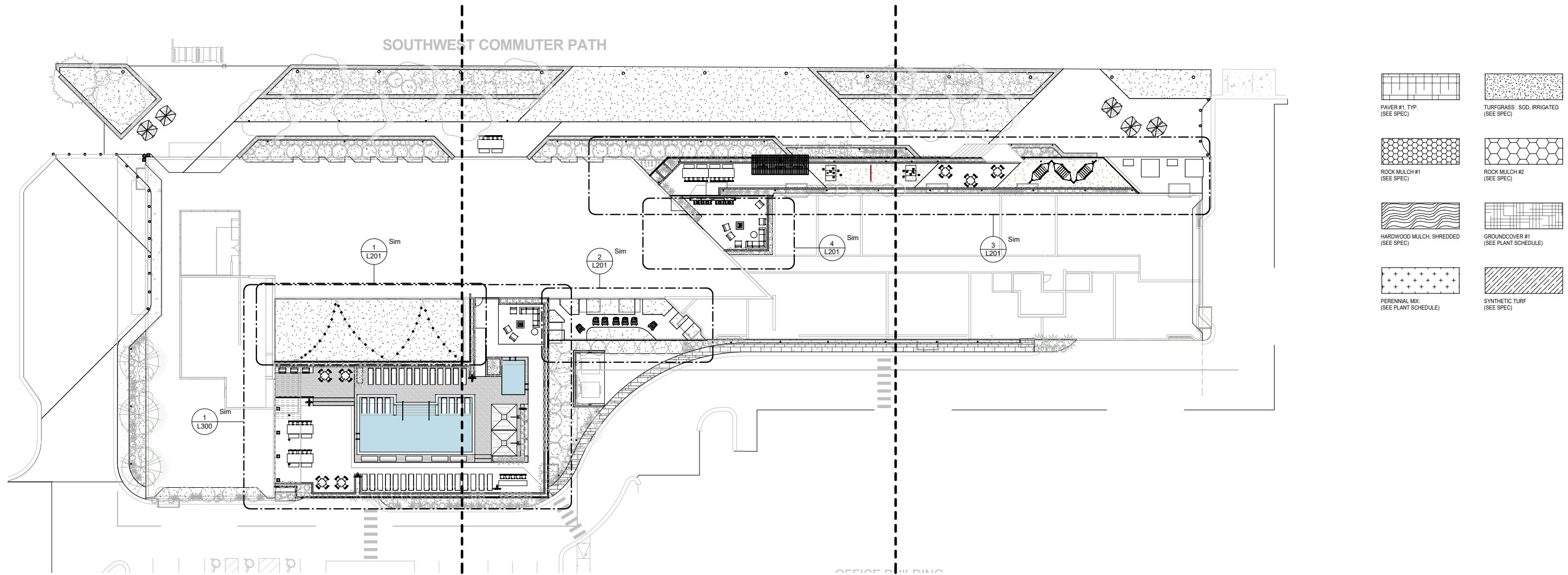

LANDSCAPE | PLANTING SCHEDULE

MATERIAL SCHEDULE								
Site Furnishings								
TAG	DESCRIPTION	Manufacturer	MATERIAL / PRODUCT	COLOR	FINISH / PATTERN	CONTACT INFO	NOTE	QUANTITY
F02	CHAIR	LANDSCAPE FORMS	CHIPMAN ARMED CHAIR	MERCURY	POWDER COATED ALUMINUM	LARA MOFFAT W/ LANDSCAPE FORMS 800-430-6206 EXT 1309	REF. PLANS FOR LOCATIONS; SUBMIT FINAL CUT SHEETS/ SPECS FOR L.A. AND OWNER APPROVAL PRIOR PURCHASE	58
F03	SITE TABLE	LOLL	LOLLYGAGGER COCKTAIL TABLE (30" ROUND)	CHARCOAL GREY	N/A	DOW O'NEAL @ DESIGN WITHIN REACH 415.816.0579	REF. PLANS FOR LOCATIONS; SUBMIT FINAL CUT SHEETS/ SPECS FOR L.A. AND OWNER APPROVAL PRIOR PURCHASE	2
F04	DINING TABLE	LOLL	ALFRESCO DINING TABLE (95")	CHARCOAL GREY	N/A	DOW O'NEAL @ DESIGN WITHIN REACH 415.816.0579	REF. PLANS FOR LOCATIONS; SUBMIT FINAL CUT SHEETS/ SPECS FOR L.A. AND OWNER APPROVAL PRIOR PURCHASE	5
F05	BAR TABLE	N/A	CUSTOM TO MATCH OUTDOOR KITCHEN FINISHES REF. DETAILS	REF. DETAILS	REF. DETAILS	N/A	REF. PLANS FOR LOCATIONS; SUBMIT FINAL CUT SHEETS/ SPECS FOR L.A. AND OWNER APPROVAL PRIOR PURCHASE	1
F08	FIRE PIT	N/A	BOL - CORTEN FIRE PIT 2'x6"	NATURAL STEEL	NATURAL	PALOFORM.COM	REF. PLANS FOR LOCATIONS; SUBMIT FINAL CUT SHEETS/ SPECS FOR L.A. AND OWNER APPROVAL PRIOR PURCHASE	2
F10	GRILL	BULL	BULL OUTLAW GRILL #26039 C.G. WITH FINISHING FRAME	NATURAL	STAINLESS	WWW.BULLBBQ.COM	REF. PLANS FOR LOCATIONS; SUBMIT FINAL CUT SHEETS/ SPECS FOR L.A. AND OWNER APPROVAL PRIOR PURCHASE	3
F12	CHAISE LOUNGE	ROVE CONCEPTS	PRESTON OUTDOOR LOUNGER	WHITE	OUTDOOR	ROVECONCEPTS.COM	REF. PLANS FOR LOCATIONS; SUBMIT FINAL CUT SHEETS/ SPECS FOR L.A. AND OWNER APPROVAL PRIOR PURCHASE	34
F14	SIDE TABLE	LOLL	RAPSON SIDE TABLE	WHITE	N/A	DOW O'NEAL @ DESIGN WITHIN REACH 415.816.0579	REF. PLANS FOR LOCATIONS; SUBMIT FINAL CUT SHEETS/ SPECS FOR L.A. AND OWNER APPROVAL PRIOR PURCHASE	2
F16	UMBRELLA (10' SQ)	TUUCI	OCEAN MASTER CLASSIC CANTILEVER W/ STNLS STEEL MAX SECURITY STEM AND STNLS BASE	WHITE	N/A	DOW O'NEAL @ DESIGN WITHIN REACH 415.816.0579	REF. PLANS FOR LOCATIONS; SUBMIT FINAL CUT SHEETS/ SPECS FOR L.A. AND OWNER APPROVAL PRIOR PURCHASE	2
F17	BAR CHAIR	Emeco	CHIPMAN BAR STOOL	MERCURY	POWDER COATED STEEL	LARA MOFFAT W/ LANDSCAPE FORMS 800-430-6206 EXT 1309	REF. PLANS FOR LOCATIONS; SUBMIT FINAL CUT SHEETS/ SPECS FOR L.A. AND OWNER APPROVAL PRIOR PURCHASE	8
F19	CHAISE LOUNGER (IN WATER)	LEDGE LOUNGER	SIGNATURE CHAISE	WHITE	N/A	LEDGELONGERS.COM	REF. PLANS FOR LOCATIONS; SUBMIT FINAL CUT SHEETS/ SPECS FOR L.A. AND OWNER APPROVAL PRIOR PURCHASE	8
F25	OUTDOOR KITCHEN	N/A	OUTDOOR KITCHEN REF. DETAILS	REF. DETAILS	REF. DETAILS	N/A	REF. PLANS FOR LOCATIONS; SUBMIT FINAL CUT SHEETS/ SPECS FOR L.A. AND OWNER APPROVAL PRIOR PURCHASE	1
F27	OUTDOOR SOFA	SIXINCH Furniture	LOLL SUNNYSIDE SOFA	TBD	TBD	DOW O'NEAL @ DESIGN WITHIN REACH 415.816.0579	REF. PLANS FOR LOCATIONS; SUBMIT FINAL CUT SHEETS/ SPECS FOR L.A. AND OWNER APPROVAL PRIOR PURCHASE	6
F28	OUTDOOR LOUNGE (SOFA)	SIXINCH Furniture	LOLL SUNNYSIDE LOUNGE CHAIR	TBD	TBD	DOW O'NEAL @ DESIGN WITHIN REACH 415.816.0579	REF. PLANS FOR LOCATIONS; SUBMIT FINAL CUT SHEETS/ SPECS FOR L.A. AND OWNER APPROVAL PRIOR PURCHASE	9
F35	CAFE TABLE	LANDSCAPE FORMS	CHIPMAN TABLE 31" DIAMETER DINING	MERCURY	POWDERCOATED ALUMINUM	LARA MOFFAT W/ LANDSCAPE FORMS 800-430-6206 EXT 1309	REF. PLANS FOR LOCATIONS; SUBMIT FINAL CUT SHEETS/ SPECS FOR L.A. AND OWNER APPROVAL PRIOR PURCHASE	8
F36	CORN HOLE	SUNNYLAND FURNITURE					REF. PLANS FOR LOCATIONS; SUBMIT FINAL CUT SHEETS/ SPECS FOR L.A. AND OWNER APPROVAL PRIOR PURCHASE	1
F45	SHADE UMBRELLA	LANDSCAPE FORMS					REF. PLANS FOR LOCATIONS; SUBMIT FINAL CUT SHEETS/ SPECS FOR L.A. AND OWNER APPROVAL PRIOR PURCHASE	5
F46	MINGLE BACKED SEATING 6 SEATS	LANDSCAPE FORMS					REF. PLANS FOR LOCATIONS; SUBMIT FINAL CUT SHEETS/ SPECS FOR L.A. AND OWNER APPROVAL PRIOR PURCHASE	3
F47	MINGLE BACKED SEATING 4 SEATS	LANDSCAPE FORMS					REF. PLANS FOR LOCATIONS; SUBMIT FINAL CUT SHEETS/ SPECS FOR L.A. AND OWNER APPROVAL PRIOR PURCHASE	2
P001	PLANTER METAL COLOR	N/A					REF. PLANS FOR LOCATIONS; SUBMIT FINAL CUT SHEETS/ SPECS FOR L.A. AND OWNER APPROVAL PRIOR PURCHASE	7
F41	POOL RULES SIGNAGE	N/A	POOL RULES SIGNAGE TO BE PROVIDED BY OWNER	TBD BY OWNER	TBD BY OWNER	TBD BY OWNER	REFER TO ARCHITECT FOR PREFERRED LOCATION; POOL CONTRACTOR TO ENSURE ALL REQUIRED POOL SIGNAGE IS INSTALLED PER TDH AND LOCAL REQUIREMENTS	8
PL01	POOL COPING	STEPSTONE	18" X 24" X 2" THICK. PRECAST MODERN POOL COPING	1801	LIGHT SANDBLAST	STEPSTONEINC.COM	EASE EXPOSED EDGES AT COPING OVERHANG. OVERHANG PER LOCAL CODE. POOL CONTRACTOR SHALL SUBMIT LAYOUT AND SHOW DRAWINGS FOR APPROVAL	4
PL03	WARNING STRIP TILE	MOSA	2" X 24" MOSA PORCELAIN TILE	TILE: TBD, GROUT: BEIGE	UNGLAZED	CANDACE@KNOXTILE.COM	CONTRACTOR TO PROVIDE QUANTITY TO ENSURE FULL COVERAGE AS SHOWN ON PLANS. CONTRANTOR SHALL SUBMIT SAMPLE TO LANDSCAPE ARCHITECT FOR APPROVAL PRIOR CONSTRUCTION	2
PL04	DEPTH AND NO DIVING MARKERS	N/A	SANDBLAST AND PAINT FILL LETTERS/ SYMBOL IN PL01 COPING	BLACK	SANDBLAST & PAINT	CONTRACTOR CHOICE	CONTRACTOR TO SUBMIT SAMPLE TO LANDSCAPE ARCHITECT FOR APPROVAL; SUBMIT LAYOUT/ SHOP DRAWINGS FOR APPROVAL	2
PL05	POOL PLASTER	DIAMOND BRITE	EXPOSED AGGREGATE POOL FINISH - WATER COLOR FINISHES	GRECIAN SLATE	PER MANUFACTURE	SGM.COM 800.641.9247	INSTALL PER MANUFACTURES INSTALL SPECIFICATIONS	2
PL06	ADA LIFT SLEEVE	N/A	ADA LIFT SLEEVE	N/A	N/A	N/A	LIFT SLEEVE FURNISHED BY POOL CONTRACTOR AND INSTALLED BY DECK CONTRACTOR PER CODE REQUIREMENTS, REFET PLAN FOR LOCATION	1
PL07	HANDRAIL	N/A	HAND - 1-1/4" DIA TUBE STAINLESS STEEL		#4 BRUSHED	CONTRACTOR CHOICE		4
PL08	POOL RULES SIGNAGE	N/A	POOL RULES SIGNAGE TO BE PROVIDED BY OWNER	TBD BY OWNER	TBD BY OWNER	TBD BY OWNER	REFER TO ARCHITECT FOR PREFERRED LOCATION; POOL CONTRACTOR TO ENSURE ALL REQUIRED POOL SIGNAGE IS INSTALLED PER TDH AND LOCAL REQUIREMENTS	1
PL10	WATERLINE DEPTH MARKER TILE	N/A	MOSA SINGLE PIECE TO MATCH WATERLINE w/PAINTEd TEXT	TILE: 270V GROUT: BLACK	UNGLAZED	CANDACE@KNOXTILE.COM	CONTRACTOR TO SUBMIT SAMPLE TO LANDSCAPE ARCHITECT FOR APPROVAL - NO SUBSTITUTIONS	2
Lighting								
L02	MUTIL-FIXTURE AREA LIGHT	Luminis	Scopo Exterior LED mounted on 13' round pole. (4) Four fixtures mounted per pole.	POWDER COATED BLACK	3000 K	LIGHTAZ.COM	Reference Electrical schedule for Pole mounting detail, Lumens, wattage, controls, etc.	1
L03	EXTERIOR STRUCTURE MOUNTED DOWN LIGHT	BK	Denali (3" diam.)	POWDER COATED BLACK	3000 K	BKLIGHTING.COM	Reference Electrical schedule for Pole mounting detail, Lumens, wattage, controls, etc.	33
L04	EXTERIOR TREE MOUNTED DOWN LIGHT	BK	Aristar	POWDER COATED BLACK	3000 K	BKLIGHTING.COM	Reference Electrical schedule for Pole mounting detail, Lumens, wattage, controls, etc.	1
L05	WALL LUMINAIRE (POOL EQUIPMENT)	Bega	22174	POWDER COATED BLACK	3000 K	BEGA.COM	Reference Electrical schedule for Pole mounting detail, Lumens, wattage, controls, etc.	1
L08	BOLLARD STREET LIGHT 84082	Bega	84082	POWDER COATED BLACK	3000 K	BEGA.COM	Reference Electrical schedule for Pole mounting detail, Lumens, wattage, controls, etc.	13
L09	GARDEN BOLLARD 77238	Bega	77238	POWDER COATED BLACK	3000 K	BEGA.COM	Reference Electrical schedule for Pole mounting detail, Lumens, wattage, controls, etc.	52
L10	PENDANT BOLLARD 24507	Bega	24507	POWDER COATED BLACK	3000 K	BEGA.COM	Reference Electrical schedule for Pole mounting detail, Lumens, wattage, controls, etc.	5
L11	POLE PROJECTOR SC655	Luminis	SC655	POWDER COATED BLACK	3000 K	LIGHTAZ.COM	Reference Electrical schedule for Pole mounting detail, Lumens, wattage, controls, etc.	5
L12	HELIO M30K4 SECURITY BOLLARDS	Helio	LBHL0-903	POWDER COATED BLACK	3000 K	FORMS-SURFACES.COM	Reference Electrical schedule for Pole mounting detail, Lumens, wattage, controls, etc.	20
L13	Linear element - Round - Direct bury				4000 K			2
Walls & Fencing								
G01A	SECURITY GATE (4' HEIGHT)	AMERISTAR	MONTAGE PLUS SELF CLOSING	BLACK	POWDER COATED STEEL	MIKE ESPINOSA @ AMERISTARFENCE.COM	INSTALL PER MANUFACTURE SPECIFICATIONS. REF. PLANS FOR LAYOUT AND GATE LOCATIONS. REF. DETAILS ON SHEETS LSXX	1
W01	STEEL FENCE (4' HEIGHT)	AMERISTAR	MONTAGE PLUS DOUBLE SWING	BLACK	POWDER COATED STEEL	MIKE ESPINOSA @ AMERISTARFENCE.COM	INSTALL PER MANUFACTURE SPECIFICATIONS. REF. PLANS FOR LAYOUT AND GATE LOCATIONS. REF. DETAILS ON SHEETS LSXX	60' - 6 1/4" 584' - 10 1/8"

2125.04 Trinitas Landscape Requirements					
2125.04 - 740 Regent Street					
City of Madison, Wisconsin Landscape Requirements					
Total Square Footage of Developed Area:	Site Area	50,900	-	Building Footprint at Grade	33,875=
					17025
Total Landscape Points Required:		17,025	/300 =	56.75	x 5 =
					283.75
		Credits/ Existing Landscaping		New/ Proposed Landscaping	
Plant type/ Element	Minimum Size at Installation	Points	Quantity	Points Achieved	Points Achieved
Overstory Deciduous Tree	2.5" Caliper	35			1.00
Tall Evergreen Tree	5-6' Tall	35			35.00
Ornamental Tree	1.5" Caliper	15			5
Upright Evergreen Shrub	3-4' Tall	10			0
Shrub, Deciduous	#3 Gallon Container Size, Min...	3			23
					69
Shrub, Evergreen	#3 Gallon Container Size, Min...	4			13
					52
Ornamental Grasses Perennials	#1 Gallon Container Size, Min. 8-18"	2			88
					176
Ornamental/Decorative Fencing or Wall	n/a	4 per 10 lineal...			0
					0
Existing Significant Specimen Tree	Minimum Size 2.5" caliper. Trees must be within developed area and cannot comprise of more than 30% of total required points.	14 per caliper inch. Max points per tree: 200			0
Landscape Furniture for Public Seating and/or Transit Connections	Furniture must be within developed area, publicly accessible, and cannot comprise more than 5% of total required points.	5 per *seat			0
					0
Subtotals					130.00
					407
				Total Points Provided:	407

MATERIALS BOARD - MP-1

RIBBED METAL PANEL

BASIS OF DESIGN | PAC CLAD PRECISION SERIES METAL PANEL (OR SIMILAR) | RANDOM BLEND: HIGHLINE S1 40%, HIGHLINE M1 60%

PACCLAD | HIGHLINE S1



COLOR | COLONIAL RED | 50%



COLOR | TERRACOTTA | 50%



PROFILE



PACCLAD | HIGHLINE M1

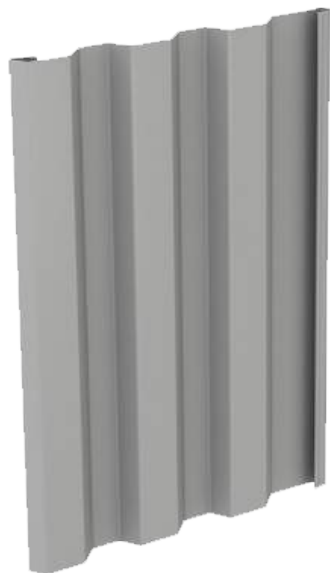

COLOR | COLONIAL RED | 50%



COLOR | TERRACOTTA | 50%



PROFILE



MATERIALS BOARD | MP-2

REVEAL METAL PANEL

BASIS OF DESIGN | METAL WALL PANEL (OR SIMILAR) | 12 INCH REVEAL

PACCLAD | REVEAL PANEL



COLOR | WEATHERED ZINC



PROFILE

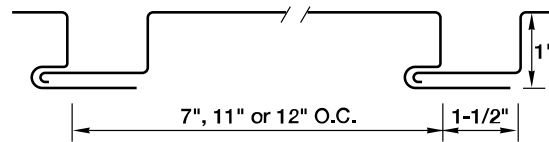

COMPOSITE METAL PANEL

BASIS OF DESIGN | ALUCOBOND (OR SIMILAR) - ALUCOBOND PLUS 40MM

COLOR | PLATINUM MICA



PROFILE



Rout & Return
Rain Screen

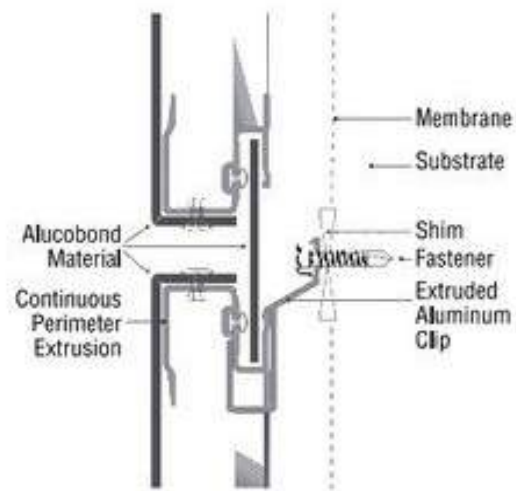

MASONRY VENEER WALL

BASIS OF DESIGN | INTERSTATE BRICK COMPANY (OR SIMILAR) | PEWTER (4" EMPEROR + 45 DEGREE SPLAY)

EMPEROR

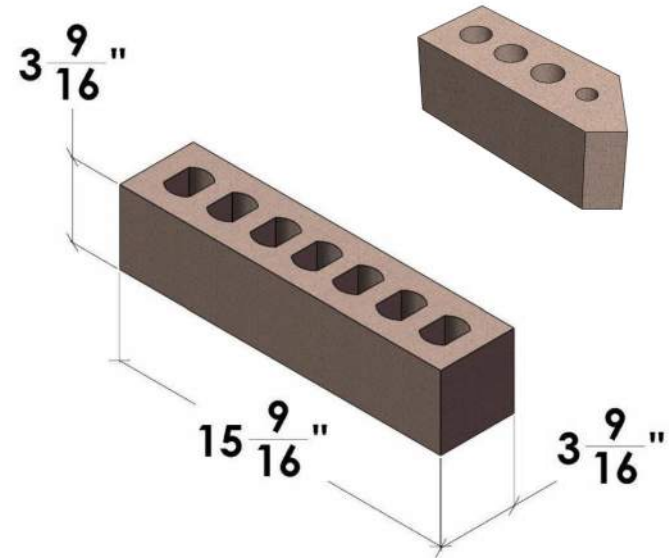

ASH

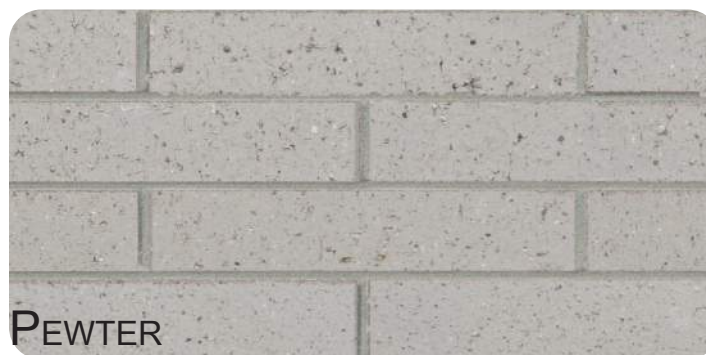

PEWTER



PERFORATED METAL PANEL

BASIS OF DESIGN | HENDRICK (OR SIMILAR) - PERFORATED METAL CLADDING

PERFORATION PATTERNS

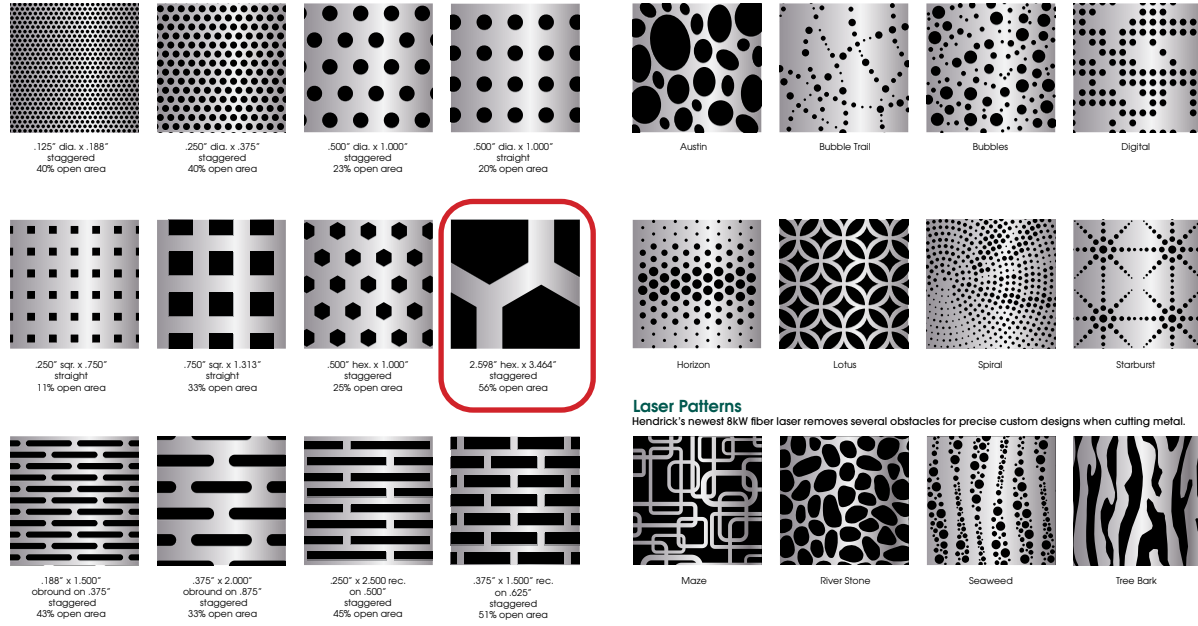

PROFILES

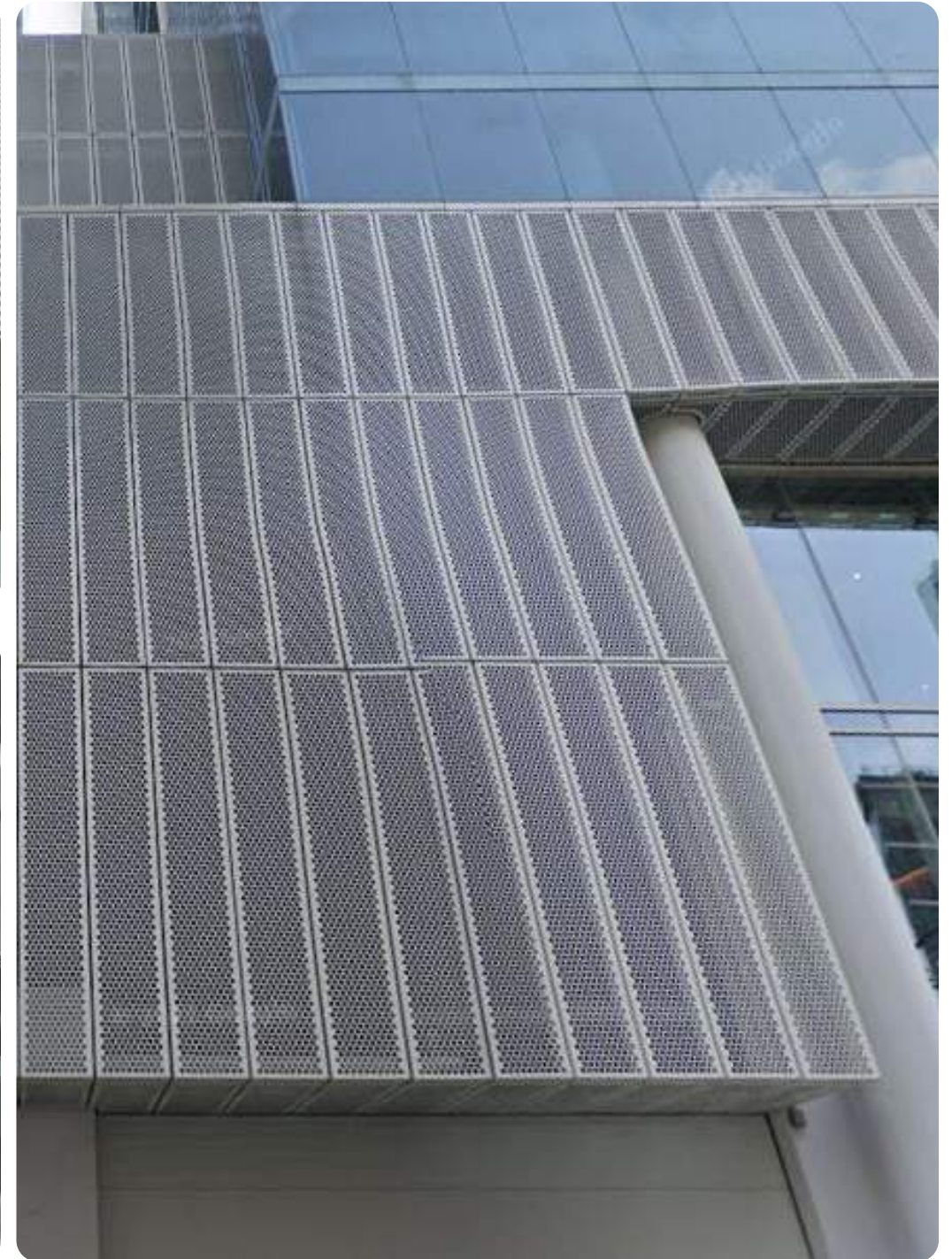
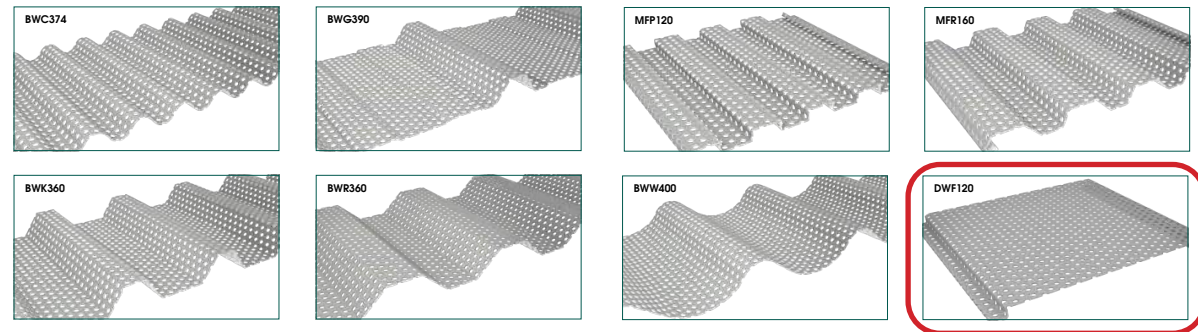

ASF-1 | ALUMINUM STOREFRONT

BASIS OF DESIGN | KAWNEER ENCORE SSG (OR SIMILAR)

DETAIL

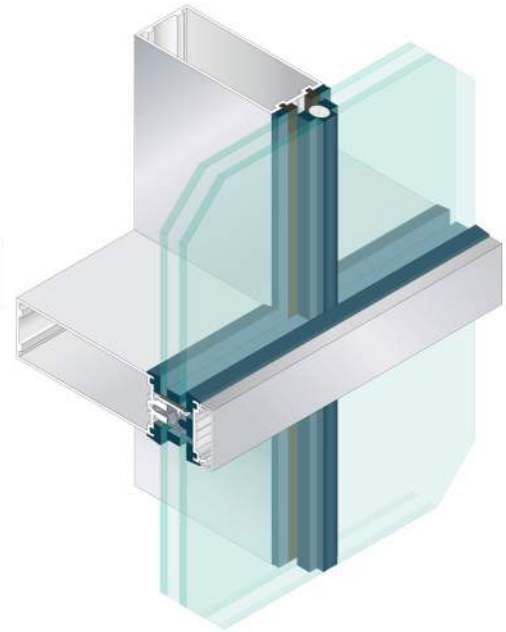

PROFILE

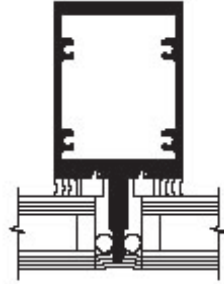

FRAME COLOR | ANODIZED ALUMINUM

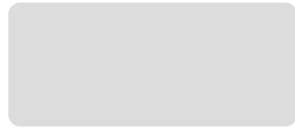

GLASS | VITRO SOLARBAN 60



MATERIALS BOARD | W-1

W-1 | FIBERGLASS WINDOW

BASIS OF DESIGN | MARVIN ESSENTIAL (OR SIMILAR)

DETAIL

FRAME COLOR | BLACK

