



# EVENT ACCESSIBILITY

Residents with disabilities are an important part of the Madison community. Under the Americans with Disabilities Act, people with disabilities must be able to enjoy “the same goods, services, facilities, privileges, advantages, or accommodations” that are available to other members of the public. This includes public events.

This guide will help you plan for accessibility and make sure your event meets the minimum requirements for an event permit from the City of Madison. We recommend that you revisit this form on the days leading up to your event and on the day of the event.

## Resources

- ADA National Network’s [A Planning Guide for Making Temporary Events Accessible to People With Disabilities](#)
- City of Madison [Disability Rights and Services](#) website has information about accessible parking, service and animals, language access services, and other topics.
- The Disability Rights and Services Program can provide you with support and consultation to help you plan an accessible event and for guidance in responding to requests for reasonable accommodations. Contact Rebecca Hoyt, Disability Rights and Services Specialist at (608) 266-6511 or [RHoyt@cityofmadison.com](mailto:RHoyt@cityofmadison.com).

## EVENT ACCESSIBILITY

These questions help the city ensure that basic elements of accessibility will be provided at your event. **Complete all parts of this form that are relevant to your event.** By submitting this form, you agree to provide the accessibility features described here at your event.

### Event Materials

Your event materials must include a contact for language access and reasonable accommodation requests on all marketing materials for the event. Sample Language: *If you need interpretation, translation, or a reasonable accommodation contact \_\_\_\_\_.*

Who will be the contact person for your event?

Name: \_\_\_\_\_

Email: \_\_\_\_\_

Phone: \_\_\_\_\_

How do you plan to provide materials in an alternative format such as braille, large print, or audio format if requested?

\_\_\_\_\_

\_\_\_\_\_

\_\_\_\_\_

Will you have volunteers or staff available to assist people with access needs on the day of the event? Who and how many?

\_\_\_\_\_

\_\_\_\_\_

\_\_\_\_\_

\_\_\_\_\_

## Accessible Routes

An accessible route must be a smooth surface, clear of obstacles, and at least 32 inches wide for one-way travel and 60 inches for two-way travel.

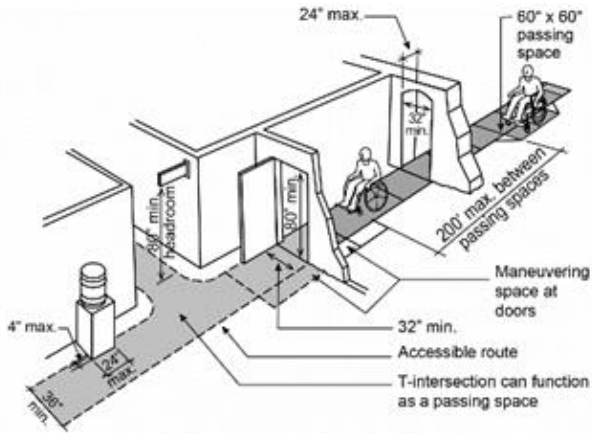

Basic Features of an Accessible Route

1. Is there an accessible route from public transit stops, drop-off locations, and parking lots to your event entrance?

---

---

---

2. Is there an accessible route to get to all features of the event such as performance areas, food vendors, exhibitors, etc.

---

---

---

3. If no, what steps will you take to ensure an accessible route? For example, temporary curb ramps or barricades.

---

---

---



If you are using an alternative route for access, you must include signage to help people with disabilities find an accessible route from public transit stops, drop-off locations, and parking lots and within the event space. Include a map with the alternative route and note the signage you will provide. A map is not required if the main entrance is accessible.

## Service Animals

Service animals are trained to do important work for people with disabilities. They must be allowed to do this work in public spaces. How will you inform staff and volunteers about [Service and Support Animal](#) requirements?

---

---

---

## Event Activities

How will you ensure that event activities are accessible to all participants?

---

---

---

If there are event activities that cannot be made accessible, what alternative activities will be made available?

---

---

---

If your event has performance areas, do you have a plan to provide captioning, assistive listening devices, and American Sign Language interpretation if requested?

---

---

The City of Madison has a wheelchair accessible stage ramp available (there may be fees for delivery). Will you need an accessible stage ramp for your event?

---

---

---

If your event will include a seating area, at least one wheelchair accessible seating area is required for every 25 seats. A space that is a minimum of 30 inches wide by 48 inches long is necessary to park a wheelchair. We recommend making wheelchair accessible seating available close to the front so that wheelchair users can sit next to non-wheelchair users who attend the event together.

Total number of seats: \_\_\_\_\_

Number of accessible seating areas: \_\_\_\_\_

**Food and Drink**

Will your event include food and drink? \_\_\_\_\_

Vendors should be advised that they will need to provide accommodations such as leaving a food truck to take orders or deliver items if counters are not accessible. How will you communicate this to vendors?

---

---

---

Dining areas should include accessible seating for people who use mobility devices. Describe accessibility features in dining areas.

---

---

---

The Parks Department has accessible picnic tables available if needed. Will you need accessible picnic tables for your event?

---

---

**Portable Restrooms**

Will you have portable restrooms? \_\_\_\_\_

At least five percent of portable toilet units must be accessible. How many portable restrooms will be provided?

---

How many will be accessible? \_\_\_\_\_

If restrooms will be provided in multiple locations, will an accessible restroom be provided in each location? Describe.

---

---

---

**Shelter**

If your event will take place outdoors, temporary shelters must be accessible for people with mobility devices. Consider if there is a smooth transition from paved pathways to grass areas and an accessible route to the shelter area.

If not accessible, what steps will you take to ensure access to shelters? For example, temporary ramps or alternative paths of travel. Describe or include a diagram.

### Exhibitor Spaces

Will your event include exhibitor spaces? \_\_\_\_\_

Exhibitor tables should be arranged with at least 36 inches of clearance and provide at least a 60-inch diameter for turning areas. For two-way travel, 60 inches of clearance is needed.

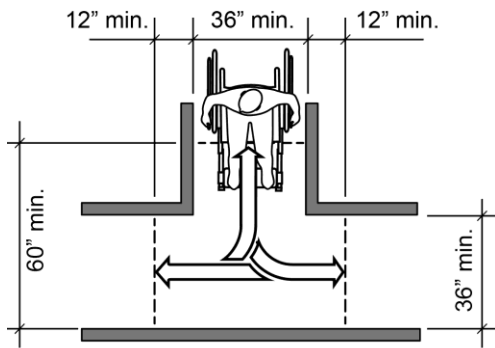

T-Turn Space

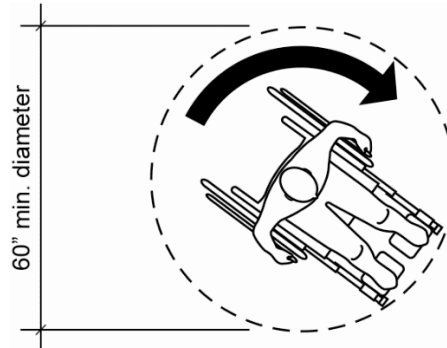

Pivoting Turn Space

Describe exhibitor spaces or include a diagram.

### Existing Facilities

Are there any accessibility concerns related to the existing facilities? Describe.

Please report accessibility issues with the existing site with enough time for repair, replacement, or assistance with temporary modification. Contact Rebecca Hoyt, Disability Rights and Services Specialist at (608) 266-6511 or [RHoyt@cityofmadison.com](mailto:RHoyt@cityofmadison.com).