

# LANDMARKS COMMISSION APPLICATION

LC

Complete all sections of this application, making sure to note the requirements on the accompanying checklist (reverse).

If you need an interpreter, translator, materials in alternate formats or other accommodations to access these forms, please call (608) 266-4635

City of Madison  
Planning Division  
126 S Hamilton St  
PO Box 2985  
Madison, WI 53701-2985  
(608) 266-4635



## 1. LOCATION

Project Address: 5 E. WILSON STREET Aldermanic District: \_\_\_\_\_

## 2. PROJECT

Project Title/Description: MADISON CLUB AWNING

This is an application for: (check all that apply)

- Alteration/Addition to a building in a Local Historic District or Designated Landmark (specify)\*\*:
  - Mansion Hill       Third Lake Ridge       First Settlement
  - University Heights       Marquette Bungalows       Landmark
- Land Division/Combination in a Local Historic District or to Designated Landmark Site (specify)\*\*:
  - Mansion Hill       Third Lake Ridge       First Settlement
  - University Heights       Marquette Bungalows       Landmark
- Demolition
- Alteration/Addition to a building adjacent to a Designated Landmark
- Variance from the Historic Preservation Ordinance (Chapter 41)
- Landmark Nomination/Rescission of Historic District Nomination/Amendment  
(Please contact the Historic Preservation Planner for specific Submission Requirements.)
- Other (specify):

DPCED USE ONLY	Registrar #:
	<b>DATE STAMP</b> <b>CITY OF MADISON</b>  <b>DEC 3 2018</b> <b>11:47</b> <b>Planning &amp; Community &amp; Economic Development</b>
	<b>Preliminary Zoning Review</b>  Zoning Staff Initial:  Date:     /     /

## 3. APPLICANT

Applicant's Name: THE MADISON CLUB Company: THE MADISON CLUB

Address: 5 E. WILSON STREET MADISON WI 53711  
Street City State Zip

Telephone: 608-255-4841 Email: mguard@madisonclub.org

Property Owner (if not applicant): \_\_\_\_\_

Address: \_\_\_\_\_

Property Owner's Signature: Mary Magrward, G. Mgr. Date: 11-26-18  
Street City State Zip

NOTICE REGARDING LOBBYING ORDINANCE: If you are seeking approval of a development that has over 40,000 square feet of non-residential space, or a residential development of over 10 dwelling units, or if you are seeking assistance from the City with a value of \$10,000 (including grants, loans, TIF or similar assistance), then you likely are subject to Madison's lobbying ordinance (Sec. 2.40, MGO). You are required to register and report your lobbying. Please consult the City Clerk's Office for more information. Failure to comply with the lobbying ordinance may result in fines.

## 4. APPLICATION SUBMISSION REQUIREMENTS (see checklist on reverse)

All applications must be filed by 12:00pm on the submission date with the Preservation Planner, the Department of Planning & Community & Economic Development, Planning Division, located at 126 S Hamilton Street. Applications submitted after the submission date or incomplete applications will be postponed to the next scheduled filing time. Submission deadlines can be viewed here: [https://www.cityofmadison.com/dpced/planning/documents/LC\\_Meeting\\_Schedule\\_Dates.pdf](https://www.cityofmadison.com/dpced/planning/documents/LC_Meeting_Schedule_Dates.pdf)



November 26, 2018

To: Landmarks Commission

Re: Installing an awning to the Madison Club

The Madison Club, located at 5 E. Wilson Street, Madison, would like to propose installing an awning along the walkway to the Club's side entrance. You will see that the Club originally had an awning running the length of the sidewalk along this entrance, and we would like to install a very similar structure. I have provided both photos of what the old awning looked like before it was destroyed in a storm approximately 15 years ago, and new photos illustrating what we are proposing. We would attach the new awning in the same areas as the old awning which would alleviate additional drilling into the façade and we are working with Gallagher Tent and Awning, which has been the company of record for this type of Club project. The awning will not only provide protection from the rain but it will also match the awning which is currently on the Hilton side entrance to create a more balanced curb appearance. We are also proposing to replace the current awning as well, with the Club crest so that both awnings would display the same artwork and numerical address. I have attached photos illustrating before and after looks, and drawings with the dimensions written in. The color would be black as portrayed, with a white trimmed scallop and white letters and numbers. The work would be done in late winter or early spring of 2019. The only differences of the old vs. new are installing additional polls for the awning to attach to which will provide more support, and the awning would extend past the doors so the back half of the sidewalk is covered as well.

Please advise if additional materials are needed. Thank you for your consideration.

Mary Gaffney-Ward  
General Manager, The Madison Club



ORIGINAL  
AWNING

5 E. WILSON



ORIGINAL  
AWNING

OLIN  
TERRACE



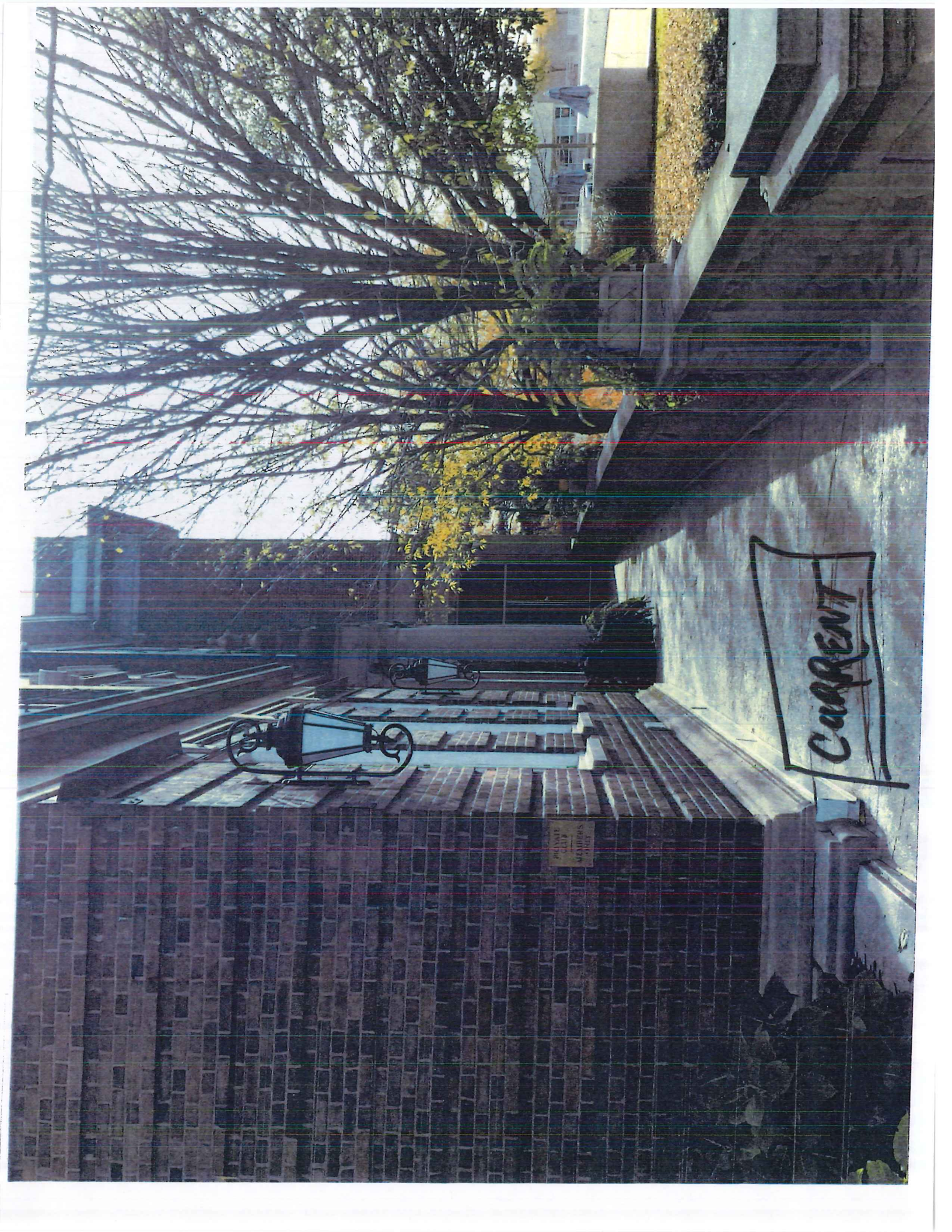

CURRENT

PRIVATE CLUB  
MEMBERS ONLY



10/1/2011



current



CURRENT





HI

17

WE /  
IN LI  
APPE

5 EAST WILSON



PROPOSED

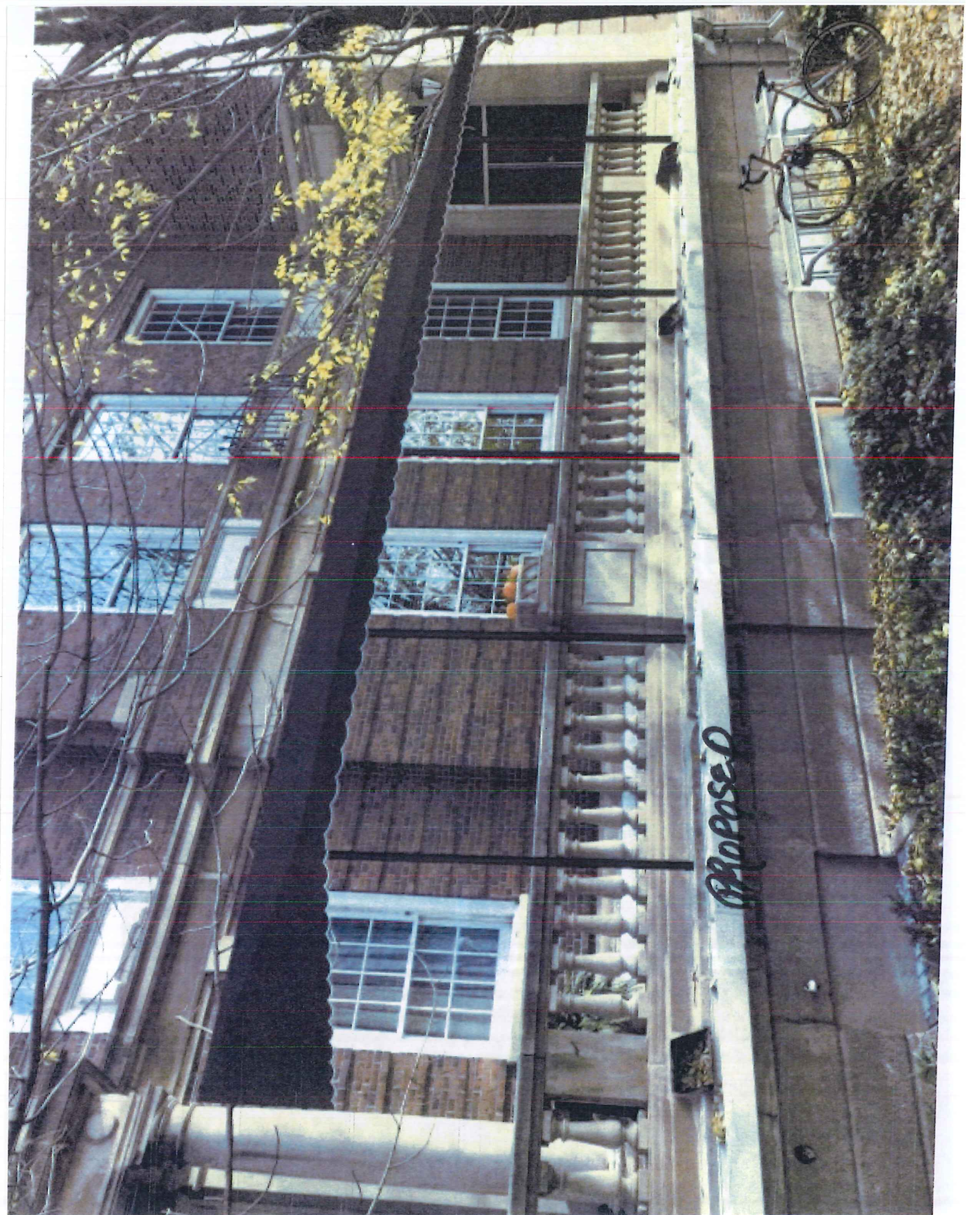

Proposed



— Proposed —

Approved

MAX AWNING PROTECTION  
OFF THE WALL  
10'-6"

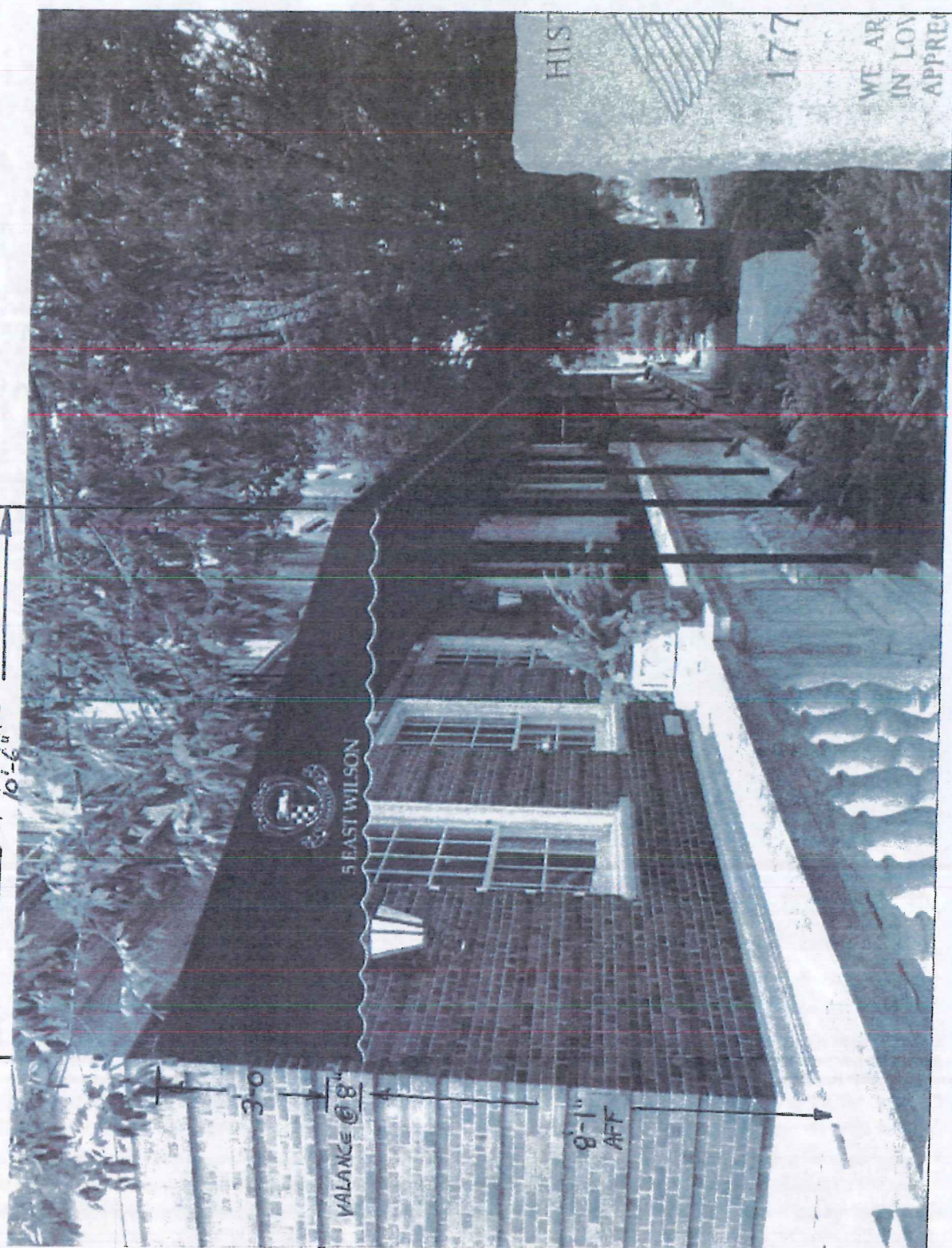

VALANCE @ 8"

8'-1"  
AFF



**GALLAGHER**  
ARCHITECTURAL SERVICES  
 (608) 255-7286  
 809 Placert Drive  
 Madison, WI 53713

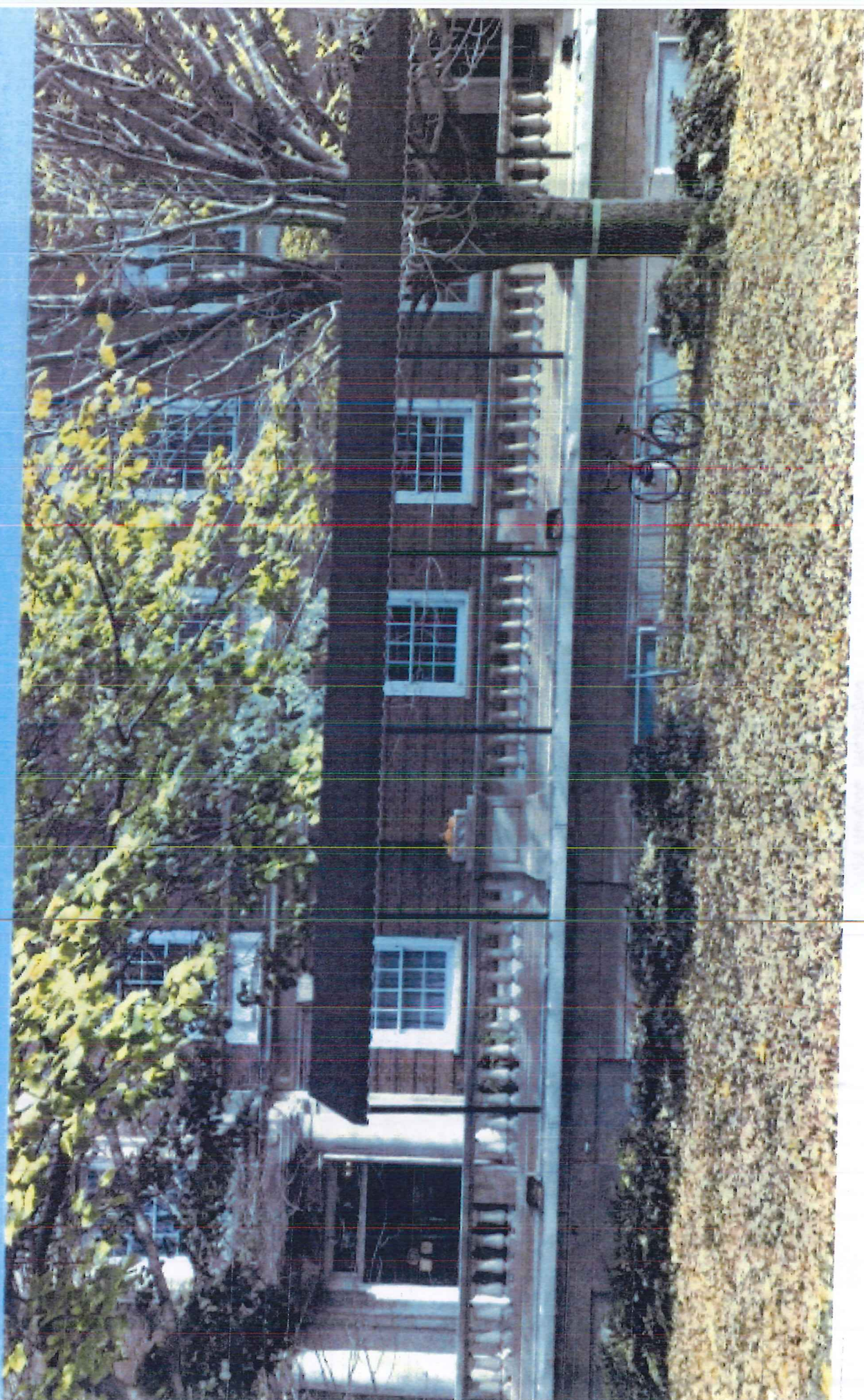

Proposed

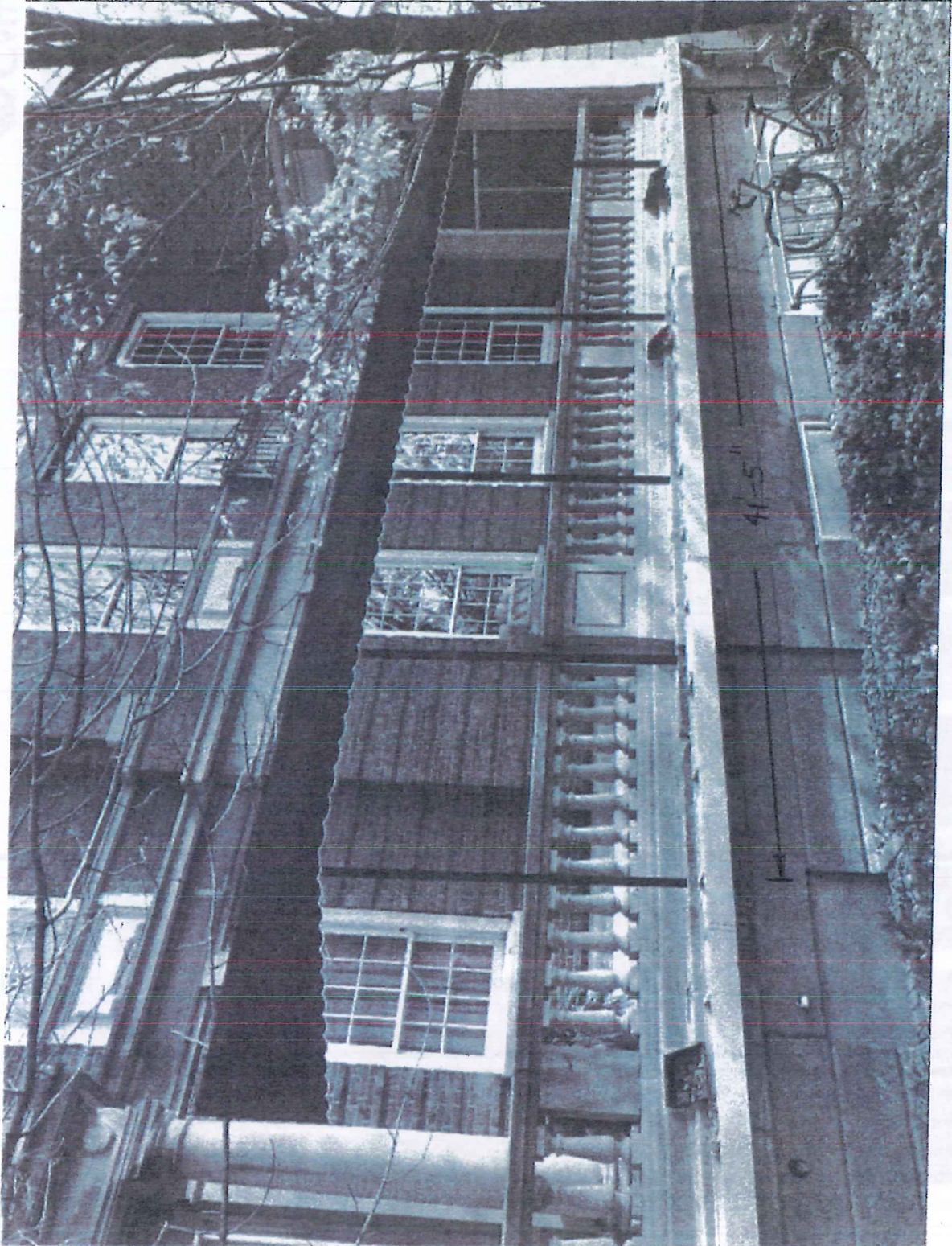

[LENGTH = 4'-5"]

**GALLAGHER**  
REAL ESTATE & MANAGEMENT  
(608) 255-7286  
809 Placeret Drive  
Madison, WI 53713

PROPERTY OF STATE  
DEPARTMENT OF  
TRANSPORTATION

WISCONSIN  
DEPARTMENT OF  
TRANSPORTATION

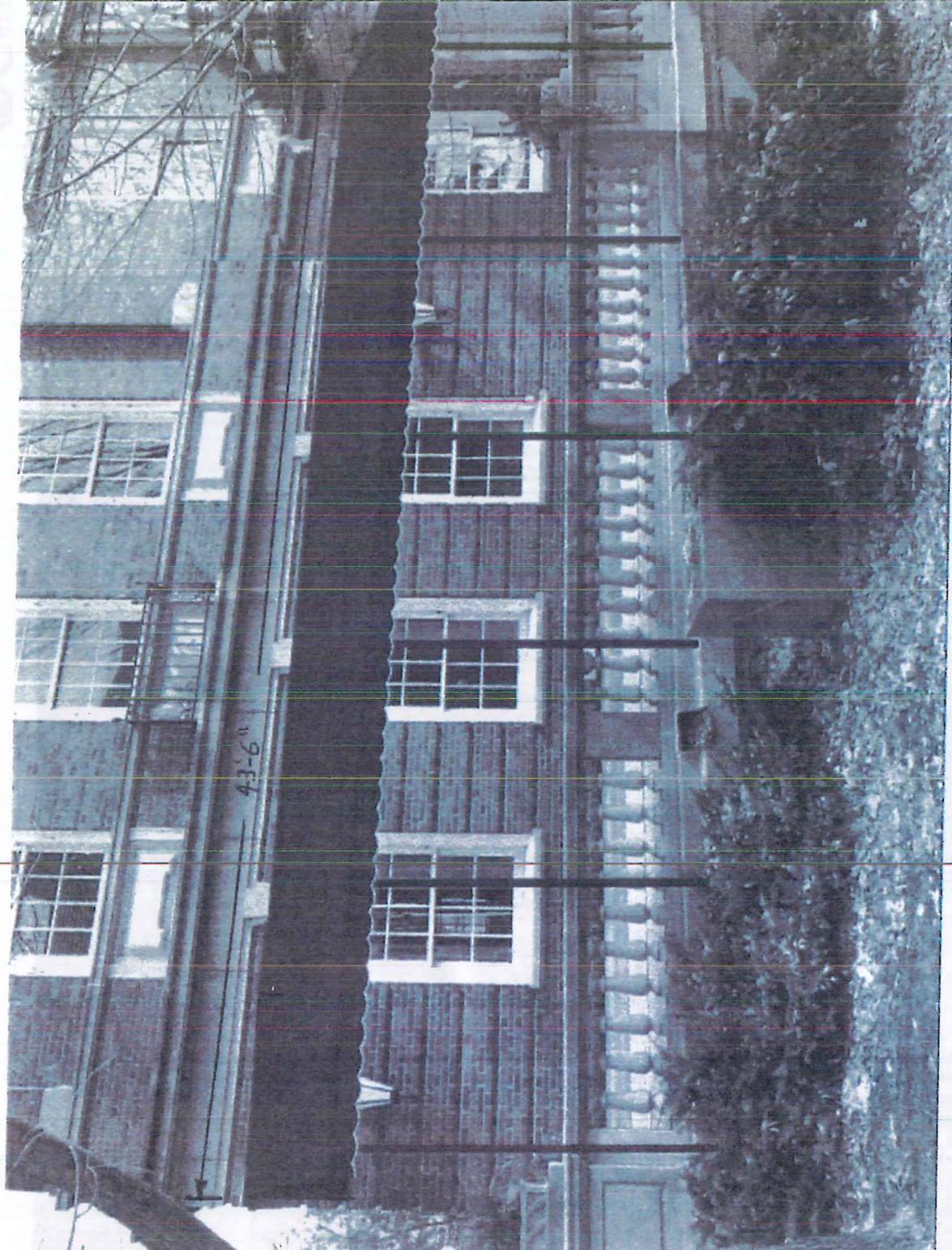

[ LENGTH = 43'-6" ]

**GALLAGHER**  
ESTABLISHED 1964

(608) 255-7286  
809 Pleasant Drive  
Madison, WI 53713



EXISTING AWNING  
HILTON SIDE



*M*

THE MADISON  
C L U B  
FIVE EAST WILSON

EXISTING  
AWNING  
HILTON SIDE



809 Plaenert Dr. Madison, WI 53713 Ph 608-255-7286; Fax 608-255-7293  
Email: gallagherawning@tds.net

Established 1880

**WARRANTY**

Gallagher Tent & Awning warranty information as follows:

\*All installation and materials used/workmanship, including fabric attachment to framework, frame attachment to building or metal roof panel attachment to frame is guaranteed for 1 year from date of installation.

\*All welded construction of framework on awnings/canopies is guaranteed for 2 years from date of installation.

\*Purchaser shall notify in writing any defects for which claim is being made.

\*Warranty does not cover failure if failure is due to ground or soil erosion, concrete pad, asphalt, or building structure failure to which awning/canopy has been anchored.

\*The warranty set forth above shall be the purchaser's sole and exclusive warranty.

\*All warranties above are effective from the date of installation or shipment from manufacturer.

\*Specific fabric and/or metal roof panel warranties vary according to type of material chosen. Please see following sheet for material warranty specific to the job.

\*The warranty set forth above shall be void if damage to the awning/canopy is caused by misuse, mechanical abrasion to the fabric or frame, exposure to corrosive or damaging chemicals or pollutants, or extreme acts of nature.

\*All graphics are guaranteed for 1 year from date of installation. Covers adherence to underlying fabric & workmanship detail of the graphic design.

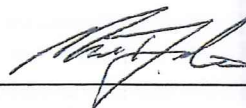
 MARK TOZJALA - VICE PRESIDENT

12/3/2018

Signed

Date

Job: The Madison Club-Madison WI

[Job: THE MADISON CLUB - WALKWAY CANOPY]

**GALLAGHER**  
 AWNING & CANOPY  
 (608) 255-7286  
 809 Plaenert Drive  
 Madison, WI 53713

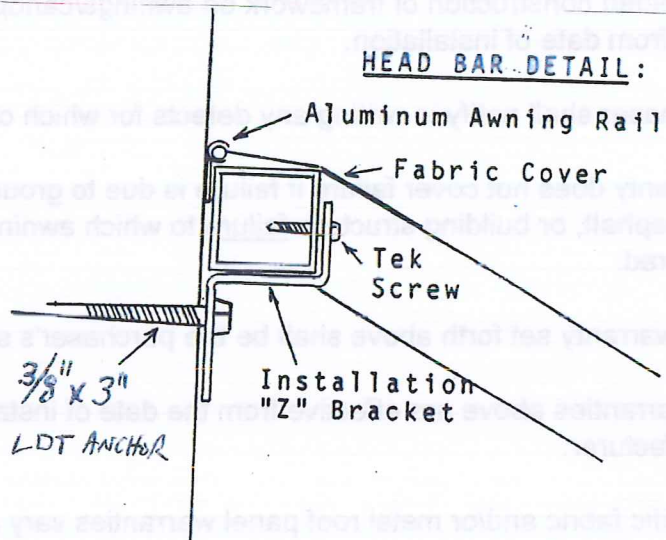
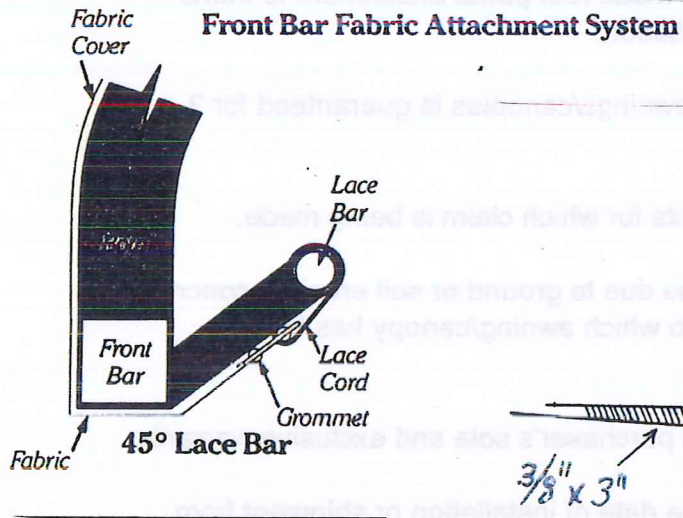

**"Z" BRACKET DETAIL**

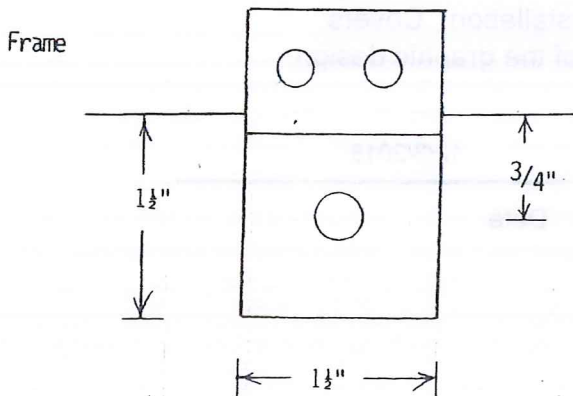

**Aluminum Tube (Square)**

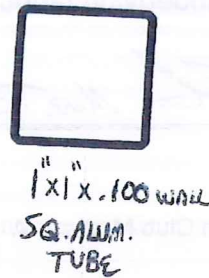

[JOB: THE MADISON CLUB - WALKWAY CANOPY]

FABRIC COVER IS SUNFIELD  
 OUTDOOR GRADE ACRYLIC (CANVAS)  
 - COLOR IS SOLID JET BUTTE

(LEFT OF ENTRY)

43'-6"

3'-0"  
 8"

10'-6"

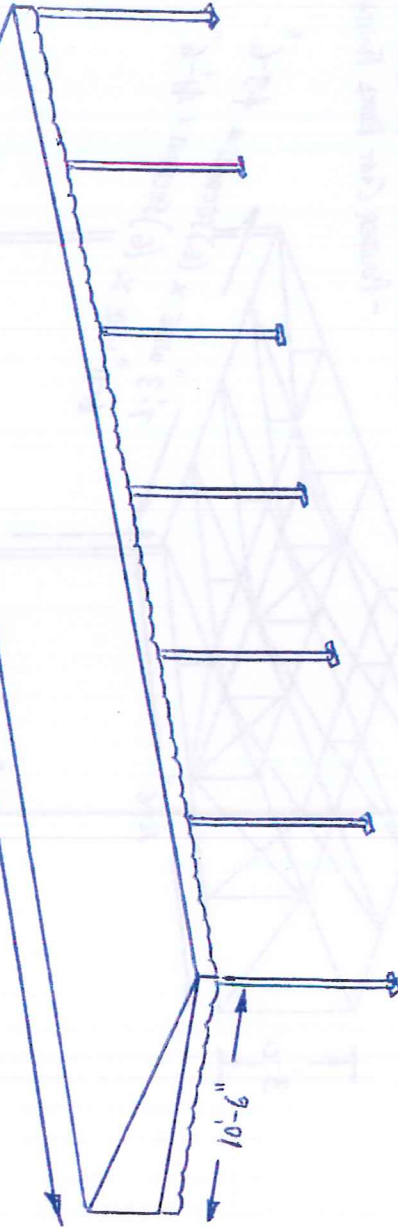

(RIGHT OF ENTRY)

41'-6"

3'-0"  
 8"

10'-6"

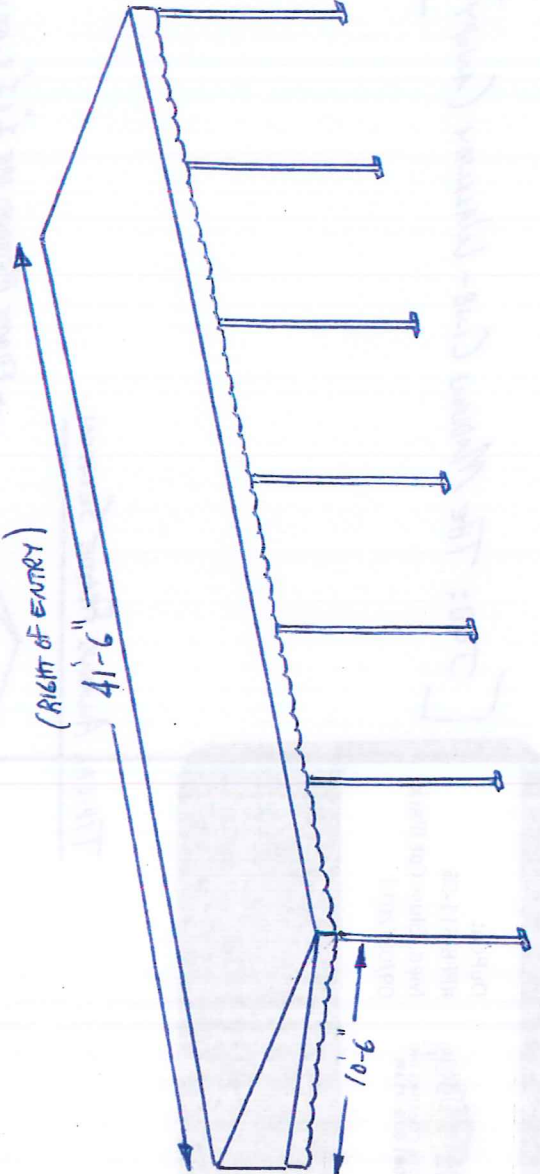

[ JOB: THE MADISON CLUB - WALKWAY CANOPY ]

DuPont  
 #PFB-611-S6  
 Med. Gloss Cat Black  
 09/05/2012

**ALL-COLOR**  
 POWDER COATING, INC.  
 (608) 835-9118

TYPICAL AWNING FRAME SECTION

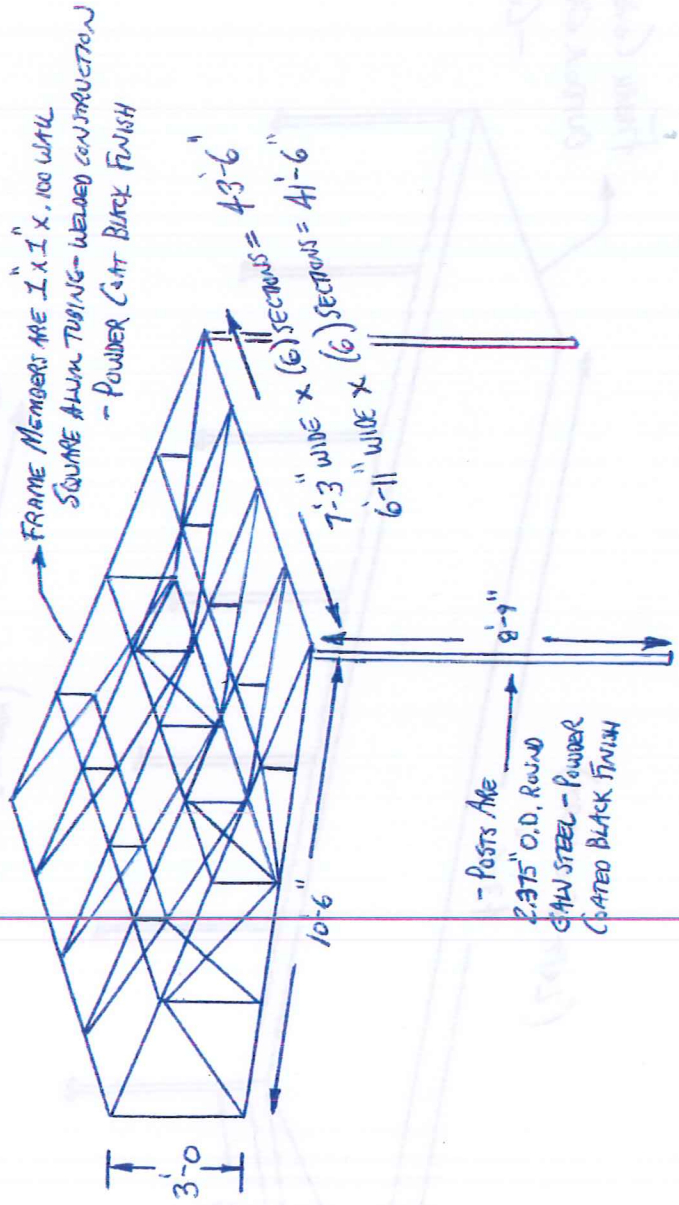

NOTE:

- FRAME SECTIONS TO BE BOLTED TOGETHER WITH  $5/16" \times 2 1/2"$  CARRIAGE BOLTS
- TOP OF SUPPORT POSTS BOLTED TO CANOPY SECTIONS WITH  $3/8" \times 1 1/4"$  BOLTS
- AWNING FRAME SECTIONS ANCHORED TO BUILDING WITH  $3/8" \times 3"$  LDT ANCHORS / Z BRACKET CLIPS

- TOP PLATE BOLTED TO CANOPY SECTION WITH (4)  $3/8" \times 1 1/4"$  BOLTS

SUPPORT POST TYPICAL

- FLOOR PLATE ANCHORED TO CONCRETE WITH (2)  $3/8" \times 3"$  LDT ANCHORS

# Technical Features

Composition	100% Solution Dyed Woven Acrylic	Mildew Resistant	Yes. (Test: AATCC30)
Warp	76 ends/inch. Yarn count: 20/2	Abrasion Resistant	Yes > 20000 cycles (Test: ASTM D 1966)
Fill	38 ends/inch. Yarn count: 20/2	Finished Widths	32", 47", & 60"
Finished Weight	305 g/sq.m (9.0 Oz/Sq. Yard)	Standard Put Up	65 yds per roll.
Tensile Strength (Grab)	Warp: 295 Lbs, Fill: 175 Lbs (Test: ASTM S 5034)	Heat Sealable	Yes with a seam tape.
Tear Strength (Tongue)	Warp: 13.8 Lbs, Fill: 9.4 Lbs (Test: ASTM D 2261)	Breathable	Yes
Water Column	>300mm (>12") (test: UNI 5122)	Translucent	Yes
Water Repellent	Yes (Test: AATCC 127-1985)	Opaque	Yes
Wetting-No. droplet saturation.	100. (Test: AATCC -22-1996)	Heat Transfer Films	Yes
Stain Repellent	Yes Protective Fluorocarbon finish.	Heat Sealed insert Fabric	Yes
Stretch Factor	Warp: 0.3%, Fill: 0.3% (Test: ASTM D 3107)	Sewn-in insert Fabric	Yes
UV Resistant	Yes: 1500+Hours (Xenon Weather meter)	Pressure Sensitive Vinyl	Yes
UV Protection	Rated: Excellent (Test: AS/NZS 4399:1996)	Silk Screening	Yes
Color Fade Resistant	Yes 7/8 -8 degree solution dyed colors (UNI 7640)	Hand Painting	Yes
Warranty	Yes 10 Years*	Uses	Awnings, Boat Covers, Banners etc.

\*The warranty is effective only if the fabric has been unserviceable because of loss of color or strength from normal exposure conditions including sunlight and atmospheric chemicals. The warranty does not apply against deterioration of any kind due to fire-accidents, burns, abusive use, malfunction, negligence, vandalism, perforations, or other acts of God. The warranty does not cover any labor or installations.

## Cleaning Instructions

Sunfield Fabrics are subjected to special treatment with a fluorocarbon which gives the following characteristics:

- Resistance to natural build up of dirt.
- Oil and water-repellency for a long time.
- Excellent dimensional stability.

However, it is advisable to :

- Remove dust periodically from the dry cover with a soft brush or a vacuum cleaner.
- Wash with clean water at a temperature of not more than 96° F (30° C), when the dirt is persistent.
- Use trichloroethylene blotter or a common dry cleaner for grease stains.
- Never use any other chemical product.
- Avoid the build up of water bags in the middle of the awning, always keeping the fabric in tension and with an adequate gradient.
- Never roll up the cover when the fabric is wet.



3525 Iron Horse Drive, Unit # 106 / Ladson, SC 29456

Phone (866) 828-7326 / (843) 408-4852

Fax (866) 547-4960 / (843) 879-9236

Email: [info@sunfieldusa.com](mailto:info@sunfieldusa.com) / Website: [www.sunfieldusa.com](http://www.sunfieldusa.com)

# AWNING & MARINE FABRIC



**BLACK 1199**  
WIDTHS 32"/47"/60"



**BURGUNDY 1308**  
WIDTHS 32"/47"/60"



**KELLY GREEN 1402**  
WIDTHS 32"/47"/60"

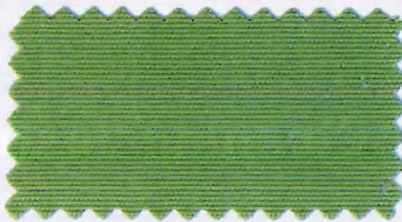

**LIME 1407**  
WIDTHS 47"



**YELLOW 1601**  
WIDTHS 47"/60"



**ORANGE 1602**  
WIDTHS 47"/60"



**GRIMSON RED 1302**  
WIDTHS 32"/47"/60"



**TRUE RED 1304**  
WIDTHS 60"



**RUST 1505**  
WIDTHS 47"/60"

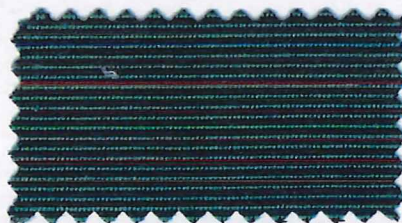

**FOREST TWEED 1801**  
WIDTHS 47"/60"

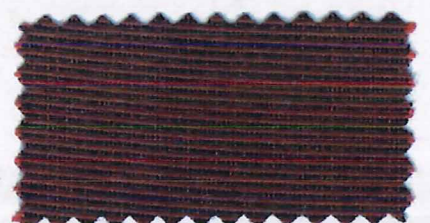

**BURGUNDY TWEED 1802**  
WIDTHS 47"/60"



**ROYAL TWEED 1803**  
WIDTHS 47"/60"



**SMOKE TWEED 1804**  
WIDTHS 47"/60"



**BALTIC TWEED 1811**  
WIDTHS 60"