

MADISON PUBLIC LIBRARY - BUDGET ANALYSIS
 For Period: 7/2014 - July 31, 2014

Balance of Year Remaining: 41.67%

	Adopted Budget	MPL Revisions	Revised Budget	YTD Actual	Variance	Percent Variance
REVENUES						
City Appropriation	(14,513,083.00)	0.00	(14,513,083.00)	(10,301,206.00)	4,211,877.00	-29.02%
Dane County	0.00	0.00	0.00	0.00	0.00	0.00%
SCLS & SWLS	(320,472.00)	0.00	(320,472.00)	(54,787.90)	265,684.10	-82.90%
LINK	(454,255.00)	0.00	(454,255.00)	0.00	454,255.00	-100.00%
Fines & Fees	(500,000.00)	(80,000.00)	(580,000.00)	(324,155.55)	255,844.45	-44.11%
Grants	(89,901.00)	(19,899.00)	(109,800.00)	(66,529.41)	43,270.59	-39.41%
Other	(48,574.00)	0.00	(48,574.00)	(49,805.19)	(1,231.19)	2.53%
Endowment Allocation	(20,000.00)	(641.06)	(20,641.06)	(20,641.06)	0.00	0.00%
Operating Transfer from Cap Proj Fund	0.00	0.00	0.00	0.00	0.00	-100.00%
Reserves Applied	(350,000.00)	(70,438.03)	(420,438.03)	0.00	420,438.03	-100.00%
Total Revenues	(16,296,285.00)	(170,978.09)	(16,467,263.09)	(10,817,125.11)	5,650,137.98	-34.31%
EXPENDITURES						
Salaries & Benefits	10,506,570.00	22,408.96	10,528,978.96	5,743,089.93	(4,785,889.03)	-45.45%
Utilities & Phones	374,141.00	0.00	374,141.00	247,221.65	(126,919.35)	-33.92%
Purchased Services	365,091.00	77,719.11	442,810.11	248,958.82	(193,851.29)	-43.78%
Computer Costs	579,926.00	0.00	579,926.00	560,554.27	(19,371.73)	-3.34%
Branch Costs	648,568.00	0.00	648,568.00	352,439.18	(296,128.82)	-45.66%
Supplies	292,570.00	47,800.00	340,370.00	244,205.96	(96,164.04)	-28.25%
Library Materials / Bindery	5,000.00	0.00	5,000.00	6,368.73	1,368.73	27.37%
Inter-Agency Charges	62,918.00	0.00	62,918.00	39,996.35	(22,921.65)	-36.43%
Debt Retirement	2,655,815.00	0.00	2,655,815.00	351,556.77	(2,304,258.23)	-86.76%
Capital Assets-Library Materials	876,036.00	23,050.02	899,086.02	346,151.67	(552,934.35)	-61.50%
Capital Assets-Other	0.00	0.00	0.00	0.00	0.00	0.00%
Inter-D Pymt from Capital Funds	(70,350.00)	0.00	(70,350.00)	0.00	70,350.00	-100.00%
Total Expenditures	16,296,285.00	170,978.09	16,467,263.09	8,140,543.33	(8,326,719.76)	-50.57%
Unrestricted Fund Balance	0.00	0.00	0.00	(2,676,581.78)	(2,676,581.78)	0.00%

MADISON PUBLIC LIBRARY - GIFTS
For The Month of JULY 2014

<u>NAME</u>	<u>AMOUNT</u>	<u>PURPOSE</u>
Ann Waidelich	\$ 5,000.00	Central: Microform Reader/Printer/Viewer/Scanner-Clear Image Solutions
Madison Public Library Foundation	\$ 500.00	CEN: Electronic Resources-Mango/Ancestry Library
Madison Public Library Foundation	\$ 200.00	Juvenile Titles for WI Book Festival
Madison Public Library Foundation	\$ 1,000.00	Juvenile - Caledcott/Newbery Books
Madison Public Library Foundation	\$ 4,430.00	Graphic Novels, Bk Festival Titles & Book Club Kit Books
Madison Public Library Foundation	\$ 250.00	PIN: Music Together Performer
Madison Public Library Foundation	\$ 3,891.28	SEQ: Blu-Ray DVDs & TV Series DVDs frm Mohaupt Endow Funds
Madison Public Library Foundation	\$ 300.00	GSMB: Mae Mitchell - Juv Pic Bks, Fiction & Non-Fiction
Madison Public Library Foundation	\$ 932.00	GSMB: Family Fun Nights Performers
Jonathan Brown	\$ 20.00	CEN: Adult Non-Fiction
Madison Eagle Auxilliary #623	\$ 187.50	CEN: Adult Large Print Books
Madison Eagle Auxilliary #623	\$ 187.50	CEN: Adult Books on CD
Rockbridge Associates Inc	\$ 75.00	CEN: Too Good To Miss Collection
Estelle K Singer	\$ 190.59	CEN: Sunday Subscription to The Oklahoman
Steven J. Mintz	\$ 36.00	LAK: Barrn's Subscription
Pierce's Supermarkets	\$ 55.29	LAK: Community Foundation Gift
Friends of Pinney Library	\$ 1,500.00	PIN: Too Good To Miss Collection
Friends of Pinney Library	\$ 300.00	PIN: Blu-Ray DVDs
Carol Y Walsh	\$ 100.00	SEQ: Playaways
Attic Angel Association	\$ 500.00	HPB: Large Print Books for Adult
Friends of Pinney Library	\$ 156.92	PIN: Meeting Room Projector Cart
Friends of Edna Taylor Conserv Park	\$ 50.00	PIN: Youth Programming
Friends of Pinney Library	\$ 1,000.00	PIN: Youth Services Supplies
County of Dane	\$ 400.00	HPB: Beyond The Page EZ Grant - R. Bessman Origami Programs
Friends of Alicia Ashman Library	\$ 150.00	HPB: Baby & Me Yoga Series
	0.00	
	0.00	
	0.00	
	<u>0.00</u>	
May, June & July Total	21,412.08	

**MADISON PUBLIC LIBRARY
CAPITAL PROJECTS STATEMENT
as of Sept 2, 2014**

Agency	Agency Description	Object Type	Sum of Budget	Sum of Actual	Sum of Encumb	Sum of Available funds
810611	Central Library- 2009/2010/2012	Expenditure City Encumb Library Encumb GO <i>Pending 'in kind'</i> Other Revenue	29,985,000.00 0.00 0.00 -17,310,000.00 0.00 -12,675,000.00	27,907,460.74 0.00 0.00 -17,310,000.00 -519,288.26 -10,504,600.00	0.00 419,092.00 61,662.44 0.00 0.00 0.00	2,077,539.26 -419,092.00 -61,662.44 0.00 519,288.26 -2,170,400.00
810611 Total			0.00	-426,427.52	480,754.44	-54,326.92
810730	Library Maintenance Vehicle-2013	Expenditure GO	40,000.00 -40,000.00	0.00 -40,000.00	0.00 0.00	40,000.00 0.00
810730 Total			0.00	-40,000.00	0.00	40,000.00
810756	Ashman Library Improvements-2013	Expenditure Other Revenue	200,000.00 -200,000.00	9,087.82 -200,000.00	0.00 0.00	190,912.18 0.00
810756 Total			0.00	-190,912.18	0.00	190,912.18
810757	Library Service & Support Center-2013	Expenditure Other Revenue	350,000.00 -350,000.00	44,216.13 -250,000.00	0.00 0.00	305,783.87 -100,000.00
810757 Total			0.00	-205,783.87	0.00	205,783.87
810758	Meadowridge Library Expansion-2013/2014	Expenditure GO Other Revenue	1,398,580.00 -1,089,473.00 -309,107.00	284,426.52 -689,473.00 -279,107.00	1,101,664.47 0.00 0.00	12,489.01 -400,000.00 -30,000.00
810758 Total			0.00	-684,153.48	1,101,664.47	-417,510.99
810773	Lakeview Library Improvements-2014	Expenditure GO	90,000.00 -90,000.00	2,722.00 0.00	0.00 0.00	87,278.00 -90,000.00
810773 Total			0.00	2,722.00	0.00	-2,722.00
810774	Eastside Libraries Planning-2014	Expenditure GO	100,000.00 -100,000.00	0.00 0.00	0.00 0.00	100,000.00 -100,000.00
810774 Total			0.00	0.00	0.00	0.00
Grand Total			0.00	-1,544,555.05	1,582,418.91	-37,863.86

MADISON PUBLIC LIBRARY

Statement Period: 05/01/14 - 05/31/14

MADISON PUBLIC LIBRARY
ATTN GREG MICKELLS DIRECTOR
201 W MIFFLIN ST
MADISON WI 53703

Administrator:
Lynne R Frank (414) 287-7225
Lynne.Frank@bmo.Com

Asset Allocation

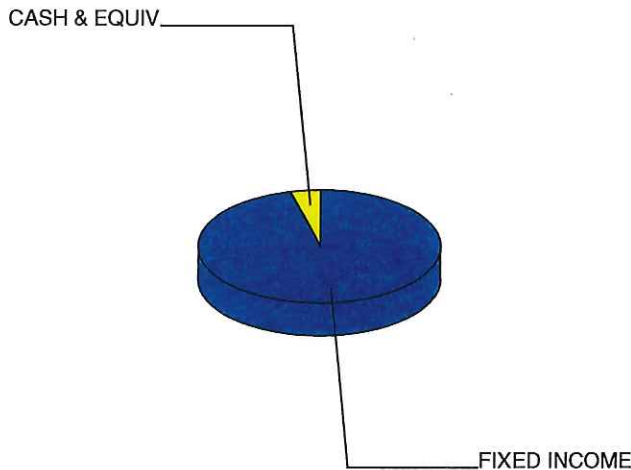

Asset Valuation

Description	Market Value	% of Account
Cash & Equiv	27,336.28	3.9%
Fixed Income	666,543.49	96.1%
Miscellaneous	0.00	
Total Portfolio	\$ 693,879.77	100.0%

Market Reconciliation

	Current Period	Year To Date
Beginning Market Value	\$ 687,800.14	\$ 758,791.28
Income		
Interest.....	3,495.43	10,407.77
Purchased Income.....	-26.37	-26.37
Disbursements		
To/for Beneficiary.....	0.00	-80,000.00
Fees/Expenses.....	-329.57	-1,793.37
Realized Gains/(Losses).....	-8.25	598.14
Change In Market Appreciation/(Depreciation).....	3,110.59	6,825.94
Non-Cash Asset Changes.....	-162.20	-923.62
Ending Market Value	\$ 693,879.77	\$ 693,879.77

MADISON PUBLIC LIBRARY

Statement Period: **06/01/14 - 06/30/14**

MADISON PUBLIC LIBRARY
ATTN GREG MICKELLS DIRECTOR
201 W MIFFLIN ST
MADISON WI 53703

Administrator:
Lynne R Frank (414) 287-7225
Lynne.Frank@bmo.Com

Asset Allocation

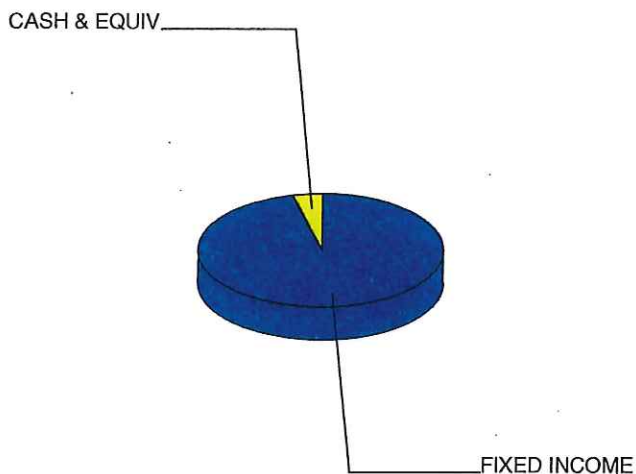

Asset Valuation

Description	Market Value	% of Account
Cash & Equiv	28,244.15	4.1%
Fixed Income	664,289.38	95.9%
Miscellaneous	0.00	
Total Portfolio	\$ 692,533.53	100.0%

Market Reconciliation

	Current Period	Year To Date
Beginning Market Value	\$ 693,879.77	\$ 758,791.28
Income		
Interest.....	936.74	11,344.51
Purchased Income.....	0.00	-26.37
Disbursements		
To/for Beneficiary.....	0.00	-80,000.00
Fees/Expenses.....	-332.48	-2,125.85
Realized Gains/(Losses).....	0.00	598.14
Change In Market Appreciation/(Depreciation).....	-1,935.74	4,890.20
Non-Cash Asset Changes.....	-14.76	-938.38
Ending Market Value	\$ 692,533.53	\$ 692,533.53

MADISON PUBLIC LIBRARY

Statement Period: 07/01/14 - 07/31/14

MADISON PUBLIC LIBRARY
ATTN GREG MICKELLS DIRECTOR
201 W MIFFLIN ST
MADISON WI 53703

Administrator:
Lynne R Frank (414) 287-7225
Lynne.Frank@bmo.Com

Asset Allocation

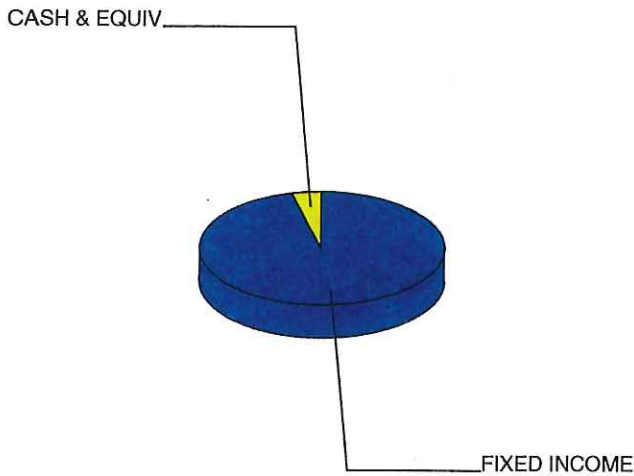

Asset Valuation

Description	Market Value	% of Account
Cash & Equiv	28,400.49	4.1%
Fixed Income	661,424.57	95.9%
Miscellaneous	0.00	
Total Portfolio	\$ 689,825.06	100.0%

Market Reconciliation

	Current Period	Year To Date
Beginning Market Value	\$ 692,533.53	\$ 758,791.28
Income		
Interest.....	464.33	11,808.84
Purchased Income.....	0.00	-26.37
Disbursements		
To/for Beneficiary.....	0.00	-80,000.00
Fees/Expenses.....	-331.84	-2,457.69
Realized Gains/(Losses).....	0.00	598.14
Change In Market Appreciation/(Depreciation).....	-2,818.26	2,071.94
Non-Cash Asset Changes.....	-22.70	-961.08
Ending Market Value	\$ 689,825.06	\$ 689,825.06