

CERTIFIED SURVEY MAP NO. _____

ALL OF LOTS 1, 2 AND PART OF LOTS 17 AND 18, BLOCK 129, ORIGINAL PLAT OF MADISON, LOCATED IN THE SOUTHWEST QUARTER OF THE SOUTHEAST QUARTER OF SECTION 13, TOWNSHIP 07 NORTH, RANGE 09 EAST, CITY OF MADISON, DANE COUNTY, WISCONSIN.

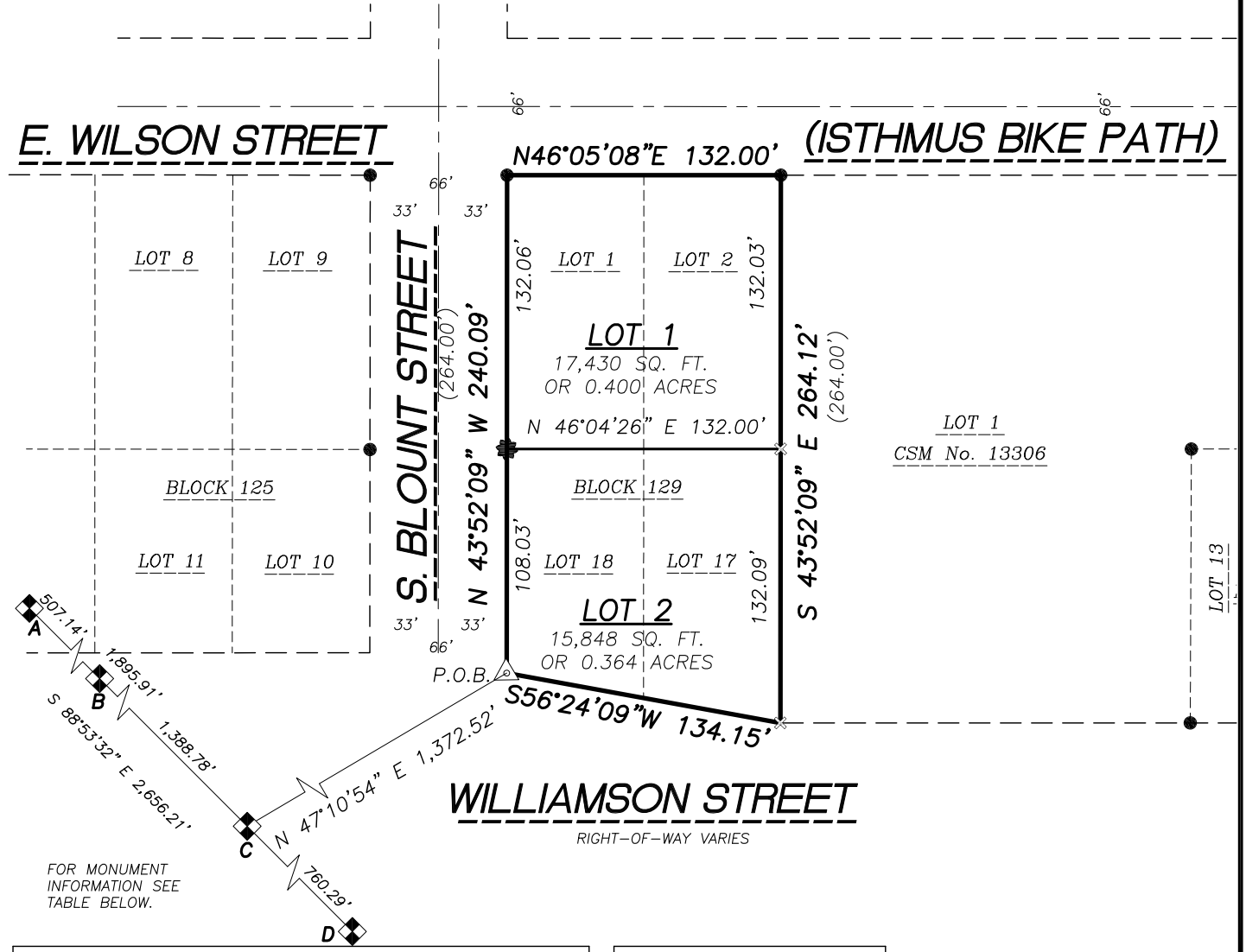

FOR MONUMENT INFORMATION SEE TABLE BELOW.

SECTION CORNER MONUMENTS				
LETTER	CORNER	FOUND	NORTHING	EASTING
A	SW 13-7-9	THE CAPITOL BLDG	482,833.37	821,166.41
B	WITNESS CORNER	BRASS CAP	482,823.95	821,673.46
C	WITNESS CORNER	BRASS CAP	482,796.72	823,061.97
D	S 1/4 13-7-9	IN THE LAKE	482,782.02	823,822.12

LINE TABLE		
LINE	BEARING	DISTANCE
A-B	S 88°56'08" E	507.14
B-C	S 88°52'36" E	1,388.78'
C-D	S 88°53'32" E	760.29'
A-C	S 88°53'32" E	1,895.91'

LEGEND

- GOVERNMENT CORNER
- 3/4" REBAR FOUND
- COTTON SPINDLE FOUND
- CHISELED 'X' FOUND
- PK/MAG NAIL FOUND
- PARCEL BOUNDARY
- RIGHT-OF-WAY LINE
- CENTERLINE
- PLATTED LOT LINE
- SECTION LINE
- EASEMENT LINE
- FENCE LINE
- GUARD OR SAFETY RAIL
- BUILDING
- RECORDED INFORMATION

NOTES

1. BEARINGS FOR THIS SURVEY AND MAP ARE REFERENCED TO THE WISCONSIN COUNTY COORDINATE SYSTEM, (WCCS DANE ZONE 1991), NORTH AMERICAN DATUM 1983(1991), (NAD 83(91)). THE SOUTH LINE OF THE SOUTHWEST QUARTER BEARS, S 88°53'32" E.
 2. FIELD WORK PERFORMED BY JSD PROFESSIONAL SERVICES, INC. THE WEEK OF AUGUST 8, 2011.
 3. ELEVATIONS FOR THIS SURVEY AND MAP ARE BASED ON THE NORTH AMERICAN VERTICAL DATUM OF 1988 (NAVD88). SITE BENCHMARK IS A BRASS CAP IN CONCRETE MONUMENT MARKING THE WITNESS CORNER TO THE SOUTHWEST CORNER OF SECTION 13, T7N, R9E, ELEVATION=918.45.
- SEE PAGE 3 OF 5 FOR ADDITIONAL NOTES 4 THRU 7 FOR EASEMENT INFORMATION.

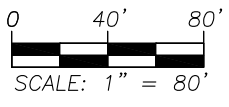

File: J:\2011\114761\dwg\11-4761 P-CSM(706).dwg Layout: Sheet 1 User: jk Plotted: May 27, 2015 - 9:36am

PREPARED BY:

 161 HORIZON DRIVE, SUITE 101
 VERONA, WISCONSIN 53593
 PHONE: (608)848-5060

PREPARED FOR:
 THE RIFKEN GROUP, LTD
 14 W. MIFFLIN ST., STE. 300
 P.O. BOX 2077
 MADISON, WI 53701-2077

PROJECT NO: 11-4761
 FILE NO: B-281
 FIELDBOOK/PG: -
 SHEET NO: 1 OF 5

SURVEYED BY: JK
 DRAWN BY: JK
 CHECKED BY: TJB
 APPROVED BY: HPJ

VOL. _____ PAGE _____
 DOC. NO. _____
 C.S.M. NO. _____

CERTIFIED SURVEY MAP NO. _____

ALL OF LOTS 1, 2 AND PART OF LOTS 17 AND 18, BLOCK 129, ORIGINAL PLAT OF MADISON, LOCATED IN THE
SOUTHWEST QUARTER OF THE SOUTHEAST QUARTER OF SECTION 13, TOWNSHIP 07 NORTH, RANGE 09 EAST,
CITY OF MADISON, DANE COUNTY, WISCONSIN.

BUILDINGS

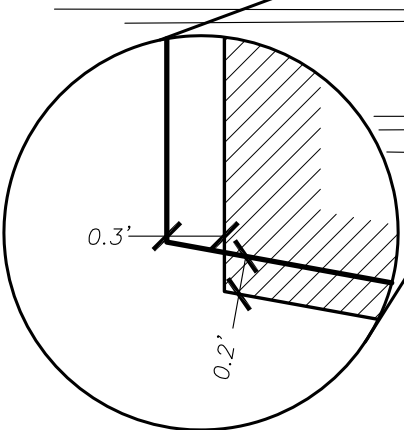
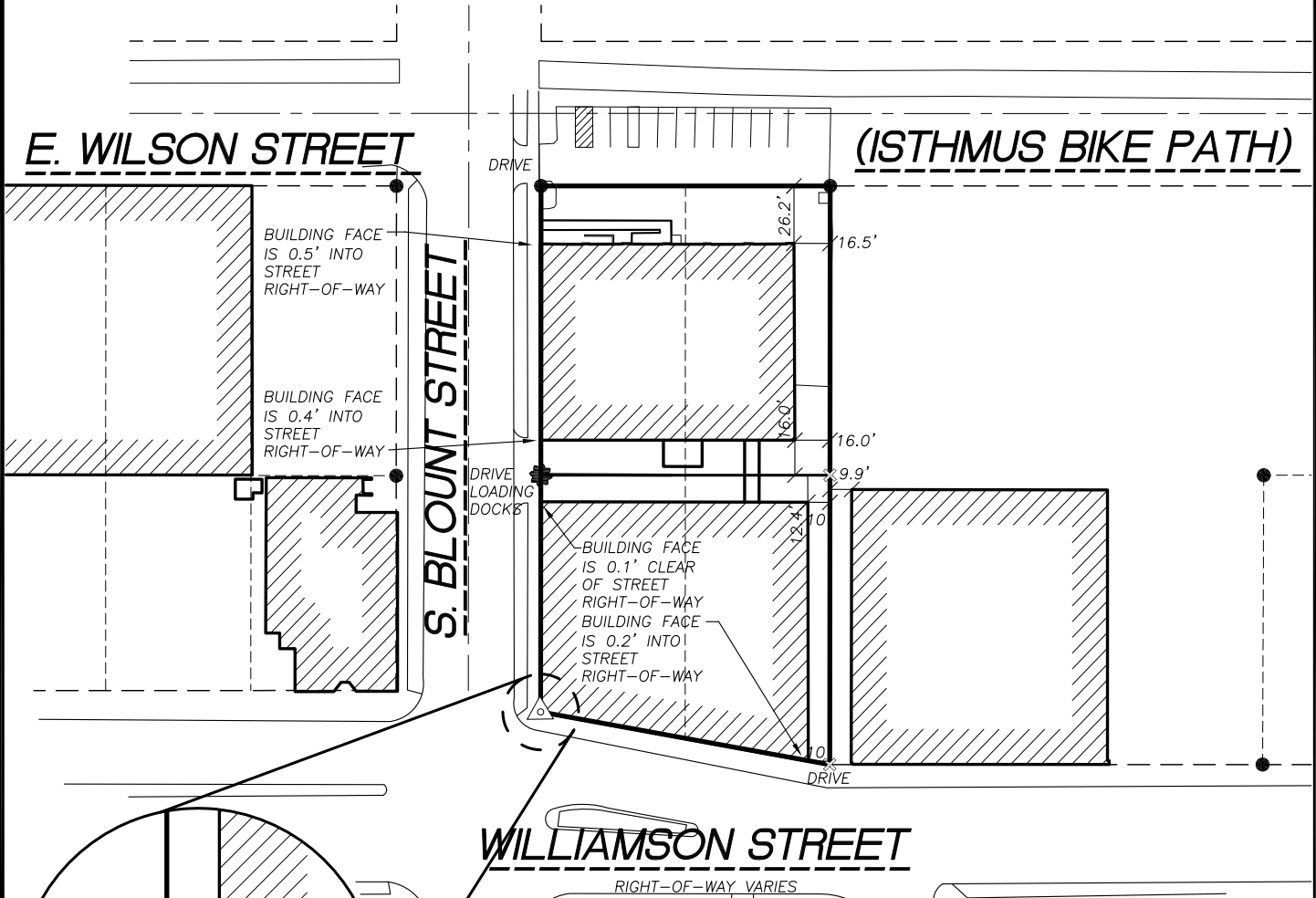

LEGEND

- GOVERNMENT CORNER
- 3/4" REBAR FOUND
- COTTON SPINDLE FOUND
- CHISELED 'X' FOUND
- PK/MAG NAIL FOUND
- PARCEL BOUNDARY
- RIGHT-OF-WAY LINE
- CENTERLINE
- PLATTED LOT LINE
- SECTION LINE
- EASEMENT LINE
- FENCE LINE
- GUARD OR SAFETY RAIL
- BUILDING
- RECORDED INFORMATION

NOTES

1. BEARINGS FOR THIS SURVEY AND MAP ARE REFERENCED TO THE WISCONSIN COUNTY COORDINATE SYSTEM, (WCCS DANE ZONE 1991), NORTH AMERICAN DATUM 1983(1991), (NAD 83(91)). THE SOUTH LINE OF THE SOUTHWEST QUARTER BEARS, S 88°53'32" E.
 2. FIELD WORK PERFORMED BY JSD PROFESSIONAL SERVICES, INC. THE WEEK OF AUGUST 8, 2011.
 3. ELEVATIONS FOR THIS SURVEY AND MAP ARE BASED ON THE NORTH AMERICAN VERTICAL DATUM OF 1988 (NAVD88). SITE BENCHMARK IS A BRASS CAP IN CONCRETE MONUMENT MARKING THE WITNESS CORNER TO THE SOUTHWEST CORNER OF SECTION 13, T7N, R9E, ELEVATION=918.45.
- SEE PAGE 3 OF 5 FOR ADDITIONAL NOTES 4 THRU 7 FOR EASEMENT INFORMATION.

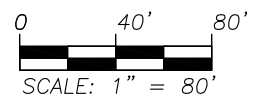

PREPARED BY:

JSD Professional Services, Inc.
Engineers • Surveyors • Planners
161 HORIZON DRIVE, SUITE 101
VERONA, WISCONSIN 53593
PHONE: (608)848-5060

PREPARED FOR:

THE RIFKEN GROUP, LTD
14 W. MIFFLIN ST., STE. 300
P.O. BOX 2077
MADISON, WI 53701-2077

PROJECT NO: 11-4761

FILE NO: B-281

FIELDBOOK/PG: -

SHEET NO: 2 OF 5

SURVEYED BY: JK

DRAWN BY: JK

CHECKED BY: TJB

APPROVED BY: HPJ

VOL. _____ PAGE _____

DOC. NO. _____

C.S.M. NO. _____

CERTIFIED SURVEY MAP NO. _____

ALL OF LOTS 1, 2 AND PART OF LOTS 17 AND 18, BLOCK 129, ORIGINAL PLAT OF MADISON, LOCATED IN THE
SOUTHWEST QUARTER OF THE SOUTHEAST QUARTER OF SECTION 13, TOWNSHIP 07 NORTH, RANGE 09 EAST,
CITY OF MADISON, DANE COUNTY, WISCONSIN.

EASEMENTS

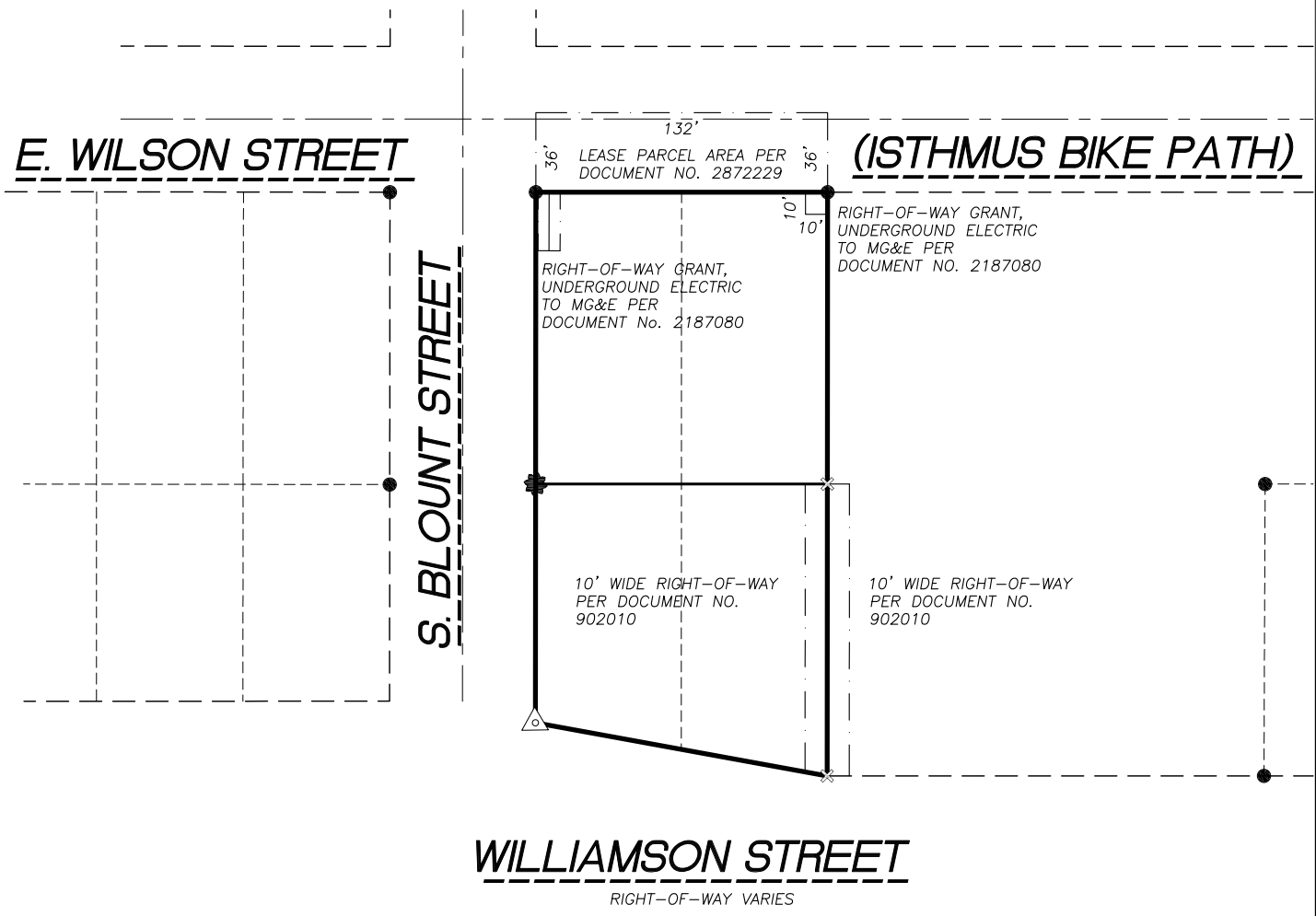

LEGEND

- GOVERNMENT CORNER
- 3/4" REBAR FOUND
- COTTON SPINDLE FOUND
- CHISELED 'X' FOUND
- PK/MAG NAIL FOUND
- PARCEL BOUNDARY
- RIGHT-OF-WAY LINE
- CENTERLINE
- PLATTED LOT LINE
- SECTION LINE
- EASEMENT LINE
- FENCE LINE
- GUARD OR SAFETY RAIL
- BUILDING
- RECORDED INFORMATION

NOTES

1. BEARINGS FOR THIS SURVEY AND MAP ARE REFERENCED TO THE WISCONSIN COUNTY COORDINATE SYSTEM, (WCCS DANE ZONE 1991), NORTH AMERICAN DATUM 1983(1991), (NAD 83(91)). THE SOUTH LINE OF THE SOUTHWEST QUARTER BEARS, S 88°53'32" E.
 2. FIELD WORK PERFORMED BY JSD PROFESSIONAL SERVICES, INC. THE WEEK OF AUGUST 8, 2011.
 3. ELEVATIONS FOR THIS SURVEY AND MAP ARE BASED ON THE NORTH AMERICAN VERTICAL DATUM OF 1988 (NAVD88). SITE BENCHMARK IS A BRASS CAP IN CONCRETE MONUMENT MARKING THE WITNESS CORNER TO THE SOUTHWEST CORNER OF SECTION 13, T7N, R9E, ELEVATION=918.45.
- SEE PAGE 3 OF 5 FOR ADDITIONAL NOTES 4 THRU 7 FOR EASEMENT INFORMATION.

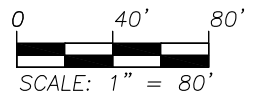

PREPARED BY:

JSD Professional Services, Inc.
Engineers • Surveyors • Planners
 161 HORIZON DRIVE, SUITE 101
 VERONA, WISCONSIN 53593
 PHONE: (608)848-5060

PREPARED FOR:

THE RIFKEN GROUP, LTD
 14 W. MIFFLIN ST., STE. 300
 P.O. BOX 2077
 MADISON, WI 53701-2077

PROJECT NO: 11-4761

FILE NO: B-281

FIELDBOOK/PG: -

SHEET NO: 3 OF 5

SURVEYED BY: JK

DRAWN BY: JK

CHECKED BY: TJB

APPROVED BY: HPJ

VOL. _____ PAGE _____

DOC. NO. _____

C.S.M. NO. _____

CERTIFIED SURVEY MAP NO. _____

ALL OF LOTS 1, 2 AND PART OF LOTS 17 AND 18, BLOCK 129, ORIGINAL PLAT OF MADISON, LOCATED IN THE SOUTHWEST QUARTER OF THE SOUTHEAST QUARTER OF SECTION 13, TOWNSHIP 07 NORTH, RANGE 09 EAST, CITY OF MADISON, DANE COUNTY, WISCONSIN.

LEGAL DESCRIPTION

ALL OF LOTS 1, 2 AND PART OF LOTS 17 AND 18, BLOCK 129, ORIGINAL PLAT OF MADISON, LOCATED IN THE SOUTHWEST QUARTER OF THE SOUTHEAST QUARTER OF SECTION 13, TOWNSHIP 07 NORTH, RANGE 09 EAST, CITY OF MADISON, DANE COUNTY, WISCONSIN, MORE PARTICULARLY DESCRIBED AS FOLLOWS:

COMMENCING AT THE SOUTHWEST CORNER OF SECTION 13, AFORESAID; THENCE SOUTH 88 DEGREES 53 MINUTES 32 SECONDS EAST ALONG THE SOUTH LINE OF THE SOUTHWEST QUARTER OF SAID SECTION A DISTANCE OF 1,895.91 FEET; THENCE NORTH 47 DEGREES 10 MINUTES 54 SECONDS EAST, 1,372.52 FEET TO THE SOUTHERLY CORNER OF BLOCK 129, ORIGINAL PLAT OF MADISON, AFORESAID, AND THE POINT OF BEGINNING; THENCE NORTH 43 DEGREES 52 MINUTES 09 SECONDS WEST ALONG THE SOUTHWESTERLY LINE OF BLOCK 129, ORIGINAL PLAT OF MADISON, 240.09 FEET; THENCE NORTH 46 DEGREES 05 MINUTES 08 SECONDS EAST ALONG THE NORTHWESTERLY LINE OF BLOCK 129, ORIGINAL PLAT OF MADISON, 132.00 FEET TO THE WESTERLY CORNER OF LOT 1, CERTIFIED SURVEY MAP No. 13306; THENCE SOUTH 43 DEGREES 52 MINUTES 09 SECONDS EAST ALONG THE LINE OF SAID CSM, 264.12 FEET TO THE SOUTHERLY CORNER THEREOF, ALSO BEING THE NORTHWESTERLY RIGHT-OF-WAY LINE OF WILLIAMSON STREET; THENCE SOUTH 56 DEGREES 24 MINUTES 09 SECONDS WEST ALONG SAID RIGHT-OF-WAY LINE, 134.15 FEET TO THE POINT OF BEGINNING.

SAID PARCEL CONTAINS 33,278 SQUARE FEET OR 0.764 ACRES.

SURVEYOR'S CERTIFICATE

I, JOHN KREBS, PROFESSIONAL LAND SURVEYOR S-1878, DO HEREBY CERTIFY THAT BY DIRECTION OF THE RIFKEN GROUP, I HAVE SURVEYED, DIVIDED, AND MAPPED THE LANDS DESCRIBED HEREON AND THAT THE MAP IS A CORRECT REPRESENTATION IN ACCORDANCE WITH THE INFORMATION PROVIDED. I FURTHER CERTIFY THAT THIS CERTIFIED SURVEY MAP IS IN FULL COMPLIANCE WITH CHAPTER 236.34 OF THE WISCONSIN STATUTES AND THE SUBDIVISION REGULATIONS OF THE CITY OF MADISON, DANE COUNTY, WISCONSIN.

JOHN KREBS, S-1878
PROFESSIONAL LAND SURVEYOR

DATE

CORPORATE OWNER'S CERTIFICATE

RIFKEN GROUP, A CORPORATION DULY ORGANIZED AND EXISTING UNDER AND BY VIRTUE OF THE LAWS OF THE STATE OF WISCONSIN, AS OWNER, DOES HEREBY CERTIFY THAT SAID CORPORATION HAS CAUSED THE LAND DESCRIBED ON THIS CERTIFIED SURVEY MAP TO BE SURVEYED, DIVIDED, MAPPED AND DEDICATED AS REPRESENTED HEREON. SAID CORPORATION FURTHER CERTIFIES THAT THIS CERTIFIED SURVEY MAP IS REQUIRED BY S.236.34, WISCONSIN STATUTES TO BE SUBMITTED TO THE CITY OF MADISON FOR APPROVAL.

IN WITNESS WHEREOF, THE SAID RIFKEN GROUP HAS CAUSED THESE PRESENTS TO BE SIGNED BY ITS REPRESENTATIVES THIS _____ DAY OF _____, 2015.

RIFKEN GROUP

BY: _____
MARTIN F. RIFKEN, MANAGING MEMBER

STATE OF WISCONSIN) SS
DANE COUNTY) SS

PERSONALLY CAME BEFORE ME THIS _____ DAY OF _____, 2015, THE ABOVE NAMED REPRESENTATIVES OF THE ABOVE NAMED MARTIN F. RIFKEN, TO ME KNOWN TO BE THE PERSON WHO EXECUTED THE FOREGOING INSTRUMENT, AND ACKNOWLEDGED THE SAME.

NOTARY PUBLIC, DANE COUNTY, WISCONSIN

MY COMMISSION EXPIRES

File: J:\2011\114761\dwg\11-4761 P-CSM(706).dwg Layout: Sheet 4 User: jk Plotted: May 27, 2015 - 9:38am

PREPARED BY:  161 HORIZON DRIVE, SUITE 101 VERONA, WISCONSIN 53593 PHONE: (608)848-5060	PREPARED FOR: THE RIFKEN GROUP, LTD 14 WEST MAIN STREET, STE. 300 P.O. BOX 2077 MADISON, WI 53701-2077	PROJECT NO: <u>11-4761</u> FILE NO: <u>B-281</u> FIELDBOOK/PG: <u>-</u> SHEET NO: <u>4 OF 5</u>	SURVEYED BY: <u>JK</u> DRAWN BY: <u>JK</u> CHECKED BY: <u>TJB</u> APPROVED BY: <u>HPJ</u>	VOL. _____ PAGE _____ DOC. NO. _____ C.S.M. NO. _____
--	---	--	--	---

CERTIFIED SURVEY MAP NO. _____

ALL OF LOTS 1, 2 AND PART OF LOTS 17 AND 18, BLOCK 129, ORIGINAL PLAT OF MADISON, LOCATED IN THE SOUTHWEST QUARTER OF THE SOUTHEAST QUARTER OF SECTION 13, TOWNSHIP 07 NORTH, RANGE 09 EAST, CITY OF MADISON, DANE COUNTY, WISCONSIN.

CONSENT OF CORPORATE MORTGAGEE

***** BANK, A CORPORATION DULY ORGANIZED AND EXISTING UNDER AND BY VIRTUE OF THE LAWS OF THE STATE OF WISCONSIN, AS MORTGAGEE OF THE LANDS DESCRIBED HEREON, HEREBY CONSENTS TO THE SURVEYING, DIVIDING, MAPPING AND RESTRICTING OF THE LANDS DESCRIBED IN THE AFFIDAVIT OF JOHN KREBS, WISCONSIN PROFESSIONAL LAND SURVEYOR, S-1878, AND DO HEREBY CONSENT TO THE ABOVE CERTIFICATE OF THE RIFKEN GROUP, LTD., OWNER.

WITNESS THE HAND AND SEAL OF ***** BANK, MORTGAGEE, THIS ___ DAY OF _____, 2015.

***** , VICE PRESIDENT

STATE OF WISCONSIN) SS
DANE COUNTY) SS

PERSONALLY CAME BEFORE ME THIS ___ DAY OF _____, 2015, THE ABOVE NAMED REPRESENTATIVES OF THE ABOVE NAMED ***** BANK, TO ME KNOWN TO BE THE PERSONS WHO EXECUTED THE FOREGOING INSTRUMENT, AND ACKNOWLEDGED THE SAME.

NOTARY PUBLIC, DANE COUNTY, WISCONSIN MY COMMISSION EXPIRES _____

CITY OF MADISON PLAN COMMISSION APPROVAL

APPROVED FOR RECORDING PER SECRETARY OF THE CITY OF MADISON PLAN COMMISSION.

***** ,
SECRETARY PLAN COMMISSION DATE _____

CITY OF MADISON COMMON COUNCIL CERTIFICATE

RESOLVED THAT THIS CERTIFIED SURVEY MAP LOCATED IN THE CITY OF MADISON WAS HEREBY APPROVED BY ENACTMENT NUMBER _____ FILE ID NUMBER _____ , ADOPTED ON THE _____ DAY OF _____ , 2015. AND THAT SAID ENACTMENT FURTHER PROVIDED FOR THE ACCEPTANCE OF THOSE LANDS DEDICATED AND RIGHTS CONVEYED BY SAID CERTIFIED SURVEY MAP TO THE CITY OF MADISON FOR PUBLIC USE.

DATED THIS _____ DAY OF _____, 2015.

MARIBETH L. WITZEL-BEHL. CITY CLERK
CITY OF MADISON, DANE COUNTY, WISCONSIN

OFFICE OF THE REGISTER OF DEEDS	
_____ COUNTY, WISCONSIN	
RECEIVED FOR RECORD _____	
20 ___ AT _____ O'CLOCK ___ M AS	
DOCUMENT # _____	
IN VOL. _____ OF CERTIFIED SURVEY	
MAPS ON PAGE(S) _____	
REGISTER OF DEEDS	

PREPARED BY:  161 HORIZON DRIVE, SUITE 101 VERONA, WISCONSIN 53593 PHONE: (608)848-5060	PREPARED FOR: THE RIFKEN GROUP, LTD 14 WEST MAIN STREET, STE 300 P.O. BOX 2077 MADISON, WI 53701-2077	PROJECT NO: 11-4761 FILE NO: B-281 FB/PG: - SHEET NO: 5 OF 5	SURVEYED BY: JK DRAWN BY: JK CHECKED BY: TJB APPROVED BY: HPJ
--	---	---	--