

**AFFIDAVIT OF MAILING**

STATE OF WISCONSIN     )  
  ) ss.  
COUNTY OF DANE         )

Marsha A. Hacker, being first duly sworn on oath, deposes and says that:

Legistar No. 49273

1. She is an Program Assistant I with the Office of the City Engineer, City of Madison, Dane County, Wisconsin, and did on the 27th of November, at approximately 1:45 pm placed in envelopes addressed to each interested owner of respective addresses as indicated by attached assessment list, a true and correct copy of the notice of assessments for the project titled Approving Plans, Specifications, and Schedule of Assessments for Westmorland Boulevard Assessment District – 2018.

2. She did and delivered the envelopes to the Mail Room of the Dane County Printing and Services Division, 210 Martin Luther King, Jr. Blvd., in the City of Madison, Dane County Wisconsin, for postage and depositing in the United States Mail.

  
\_\_\_\_\_  
Marsha A. Hacker

Subscribed and sworn to before me  
this 27 day of Nov, 2017

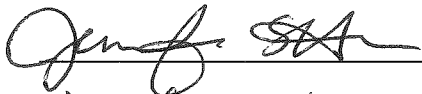
  
\_\_\_\_\_  
Jennifer S Haar  
Notary Public, State of Wisconsin  
My Commission expires: 2-2-2019

JENNIFER S. HAAR  
NOTARY PUBLIC  
STATE OF WISCONSIN



## Finance Department

---

Room 406  
210 Martin Luther King, Jr. Boulevard  
Madison, Wisconsin 53703-3345  
PH 608 266 4671  
FAX 608 267 8705  
[finance@cityofmadison.com](mailto:finance@cityofmadison.com)

Dear Property Owner:

The City of Madison has levied a special assessment on your property as shown on the enclosed Common Council resolution. This is an estimated assessment. When construction has been completed, the actual cost of the improvement will be determined. The amount of the assessment will then be adjusted accordingly, and a formal bill sent to you. The final bill will be equal to or less than the estimate unless you authorize additional work.

When you receive the bill, there are two options for payment: (1) the entire amount may be paid without interest by October 31 of the year you receive the bill (usually the next calendar year after the actual construction); or (2) if not paid in full by October 31, the assessment may be paid in installments with one equal part of the assessment plus interest included on your tax bill at the end of each year. Interest on each installment is calculated at three percent (3.0%) per year. In the first year of the assessment, interest is calculated only from the date of bill.

There may be situations, such as selling or refinancing your property, where you will be required at the closing to pay the estimated assessment before the work is completed. If the final amount is more than the estimate, any payments you have made will be credited and a bill sent out for the difference. If the final bill is less, any overpayment of principal and interest will be refunded. Refunds will be issued to the owner of record at the time of refund unless you provide the Finance Department with other refund instructions separate from the payment itself.

If your gross annual income is less than \$47,600 (for a single person, more for a family) and you live on the property where the work is done, you may qualify for a loan to pay the assessment. For information on the loan criteria, call (608) 266-4008.

We hope this letter will assist you in understanding the special assessment payment procedure. If you have any questions, please contact the City Finance Department, Room 406, 210 Martin Luther King, Jr. Blvd. or call (608) 266-4008.

Sincerely,

David Schmiedicke  
Finance Director

Enclosure



Department of Public Works  
**Engineering Division**  
 Robert F. Phillips, P.E., City Engineer

City-County Building, Room 115  
 210 Martin Luther King, Jr. Boulevard  
 Madison, Wisconsin 53703  
 Phone: (608) 266-4751  
 Fax: (608) 264-9275  
[engineering@cityofmadison.com](mailto:engineering@cityofmadison.com)  
[www.cityofmadison.com/engineering](http://www.cityofmadison.com/engineering)

**Assistant City Engineer**  
 Gregory T. Fries, P.E.  
 Kathleen M. Cryan

**Principal Engineer 2**  
 Christopher J. Petykowski, P.E.  
 John S. Fahrney, P.E.

**Principal Engineer 1**  
 Christina M. Bachmann, P.E.  
 Eric L. Dundee, P.E.

**Facilities & Sustainability**  
 Jeanne E. Hoffman, Manager

**Mapping Section Manager**  
 Eric T. Pederson, P.S.

**Financial Manager**  
 Steven B. Danner-Rivers

**RESIDENTIAL DRIVEWAY OPENING**  
**REQUEST**

The street which abuts your property is scheduled for reconstruction. Drive aprons will be removed and replaced. Abutting the sidewalk, the new drive apron will be constructed to the width of the driveway behind the property line. All new drive aprons will usually be flared 2 feet on each side of the curb opening. If you desire a change in the driveway location or dimensions, it is necessary that you complete the diagram below, sign, and return this form within two (2) weeks to the City Engineering Division, Room 115, City-County Building, Madison, Wisconsin, 53703.

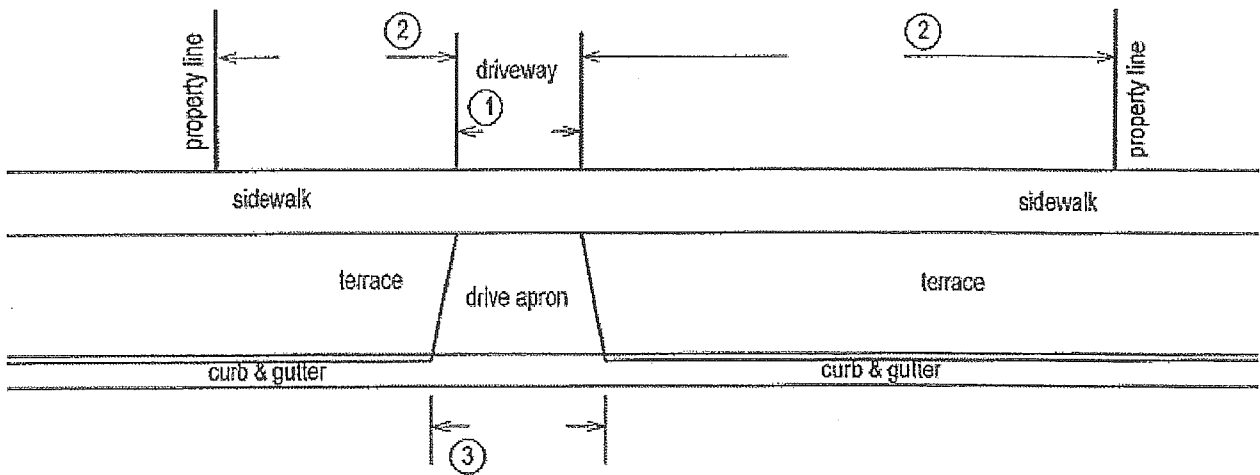

This diagram is not to any scale. Please provide:

1. The width of the driveway;
2. The distances from the edge of the driveway to the property lines;
3. The width of the desired curb opening

Residential curb openings are usually equal to the width of the driveway behind the property line at the sidewalk and an additional four (4) feet at the curb. The additional width at the curb opening is provided to facilitate turns into the driveway from the street and to taper the curb to full height. Depending on the width of the existing driveway, the City Ordinances allow up to a 20-foot wide apron at the sidewalk if necessary and requested by the property owner. In the case of vacant lots, no driveway opening will be made unless this form is returned to the City Engineering Division with the necessary information.

If the requested drive apron is larger than what has been estimated on the attached schedule of assessments, I hereby request that the City of Madison include this additional cost in my assessment for the Street Improvement.

Street Address \_\_\_\_\_

Phone No. \_\_\_\_\_

Signed \_\_\_\_\_

Date \_\_\_\_\_

Property Owner

This form is for a residential site only (a residential structure with 4 or less parking stalls). For additional information or questions, please contact the Project Engineer of the City Engineering Division at 266-4751.

**A.Z.**



# City of Madison

City of Madison  
Madison, WI 53703  
www.cityofmadison.com

## Master

File Number: 49273

<b>File ID:</b> 49273	<b>File Type:</b> Resolution	<b>Status:</b> Passed
<b>Version:</b> 1	<b>Reference:</b>	<b>Controlling Body:</b> BOARD OF PUBLIC WORKS
<b>Lead Referral:</b> BOARD OF PUBLIC WORKS	<b>Cost:</b>	<b>File Created Date :</b> 10/23/2017
<b>File Name:</b> Approving Plans, Specifications, And Schedule Of Assessments For Westmorland Boulevard Assessment District - 2018.		<b>Final Action:</b> 11/21/2017

**Title:** Approving Plans, Specifications, And Schedule Of Assessments For Westmorland Boulevard Assessment District - 2018.

**Notes:** Andy Z.

<b>Code Sections:</b>	<b>CC Agenda Date:</b> 11/21/2017
<b>Indexes:</b>	<b>Agenda Number:</b> 4.
<b>Sponsors:</b> BOARD OF PUBLIC WORKS	<b>Effective Date:</b> 11/27/2017
<b>Attachments:</b> 11675EN-Plan4_100scale.pdf, Westmorland_BPWnotes.pdf, BPW Hearing Notice_Westmorland Blvd Assessment District 2018.pdf, CC Hearing Notice_11675 Westmorland Blvd.pdf, 11675_Westmorland_Assess.pdf	<b>Enactment Number:</b> RES-17-00881
<b>Author:</b> Rob Phillips, City Engineer	<b>Hearing Date:</b> 11/21/2017
<b>Entered by:</b> mhacker@cityofmadison.com	<b>Published Date:</b>

### Approval History

Version	Date	Approver	Action
1	11/06/2017	Travis J. Martin	Approve

### History of Legislative File

Ver- sion:	Acting Body:	Date:	Action:	Sent To:	Due Date:	Return Date:	Result:
1	Engineering Division	10/23/2017	Refer	BOARD OF PUBLIC WORKS	11/01/2017		
<b>Action Text:</b> This Resolution was Refer to the BOARD OF PUBLIC WORKS due back on 11/1/2017							
<b>Notes:</b>							

---

1	BOARD OF PUBLIC WORKS	11/01/2017	RECOMMEND TO COUNCIL TO ADOPT UNDER SUSPENSION OF RULES 2.04, 2.05, 2.24 & 2.25 - PUBLIC HEARING	Pass
---	-----------------------	------------	--	------

**Action Text:** Christy Bachmann, City Engineering Division, presented project details. There were no members of the public present for the public hearing.  
A motion was made by Branson, seconded by Ald. Clear, to RECOMMEND TO COUNCIL TO ADOPT UNDER SUSPENSION OF RULES 2.04, 2.05, 2.24 & 2.25 - PUBLIC HEARING. The motion passed by voice vote/other.

**Notes:**

1	COMMON COUNCIL	11/21/2017	Adopt Under Suspension of Rules 2.04, 2.05, 2.24, and 2.25, and Close the Public Hearing	Pass
---	----------------	------------	--	------

**Action Text:** A motion was made by Rummel, seconded by Baldeh, to Adopt Under Suspension of Rules 2.04, 2.05, 2.24, and 2.25, and Close the Public Hearing. The motion passed by voice vote/other.

**Notes:**

---

**Text of Legislative File 49273**

**Fiscal Note**

The proposed resolution approves plan documents for the Westmorland Boulevard Assessment District for 2018. The proposed 2018 capital budget provides funding for the Westmorland Boulevard resurfacing project via the Pavement Management program within Engineering Major Streets' capital budget (MUNIS 11675). The total estimated project cost is \$1,670,950 of which \$117,238 is estimated to be funded by special assessments. Street and utility components are estimated to be split as follows:

- Major Streets - \$521,000
- Sewer Utility - \$350,000
- Stormwater Utility - \$282,000
- Water Utility - \$300,000

**Title**

Approving Plans, Specifications, And Schedule Of Assessments For Westmorland Boulevard Assessment District - 2018.

**Body**

The Board of Public Works and the City Engineer having made reports of all proceedings in relation to the improvement of Westmorland Boulevard Assessment District - 2018 pursuant to a resolution of the Common Council, RES-17-00828, ID No. 48990, adopted 10/17/17, which resolution was adopted thereto, and the provisions of the Madison General Ordinances and the Wisconsin Statutes in such case made and provided, and the Common Council being fully advised.

**BE IT RESOLVED:**

1. That the City at large is justly chargeable with and shall pay the sum of \$1,553,711.70 of the entire cost of said improvement.

2. That for those eligible property owners requesting construction of a rain garden in the public right-of-way adjacent to their property shall execute the necessary waiver of special assessments on forms provided by the City Engineer;
3. That the sum assigned to each separate parcel, as indicated on the attached schedule of assessment, is hereby specially assessed upon each such parcel.
4. That the Common Council determines such special assessments to be reasonable.
5. That the work or improvement be carried out in accordance with the reports as finally approved.
6. That such work or improvement represents an exercise of the police power of the City of Madison.
7. That the plans & specifications and schedule of assessments in the Report of the Board of Public Works and the Report of the City Engineer for the above named improvement be and are hereby approved.
8. That the Board of Public Works be and is hereby authorized to advertise for and receive bids for the said improvements.
9. That the due date by which all such special assessments shall be paid in full is October 31st of the year in which it is billed, or,
10. That such special assessments shall be collected in eight (8) equal installments, with interest thereon at 3.0 percent per annum, except those special assessments paid in full on or before October 31st of that year.
11. That the Mayor and City Clerk are hereby authorized to accept dedication of lands and/or easements from the Developer/Owner for public improvements located outside of existing public fee title or easement right-of-ways.

#### INSTALLMENT ASSESSMENT NOTICE

Notice is hereby given that a contract has been (or is about to be) let for Westmorland Boulevard Assessment District - 2018 and that the amount of the special assessment therefore has been determined as to each parcel of real estate affected thereby and a statement of the same is on file with the City Clerk; it is proposed to collect the same in eight (8) installments, as provided for by Section 66.0715 of the Wisconsin Statutes, with interest thereon at 3.0 percent per annum; that all assessments will be collected in installments as above provided except such assessments on property where the owner of the same has paid the assessment to the City Treasurer on or before the next succeeding November 1st.

#### NOTICE OF APPEAL RIGHTS

"Pursuant to Sec.4.09(14), Madison General Ordinances, as authorized by Sec. 66.0701(2), Wisconsin Statutes, any person against whose land a special assessment has been levied by this resolution has the right to appeal therefrom in the manner prescribed in Sec. 66.0703(12), Wisconsin Statutes, within forty (40) days of the day of the final determination of the Common Council, said date being the date of adoption of this resolution."

Parcel No.	Owner's Name / Mailing Address	Parcel Location	Frontage		Remove Concrete Driveway @ \$1.50 per SF		Replace Concrete Driveway Apron @ \$4.00 per SF		Replace Asphalt Driveway Apron @ \$4.00 per SF		Street Construction Items		Insert Street Improvements, Repave & Repair Curb & Other @ \$18.00 per LF		Initial Street Improvements, 4' Pavement & Curb @ \$46.00 per Linear Foot (LF)		Sanitary Sewer Reconstructing Items		Remove & Replace Sanitary Lateral @ \$21.00 per LF		TOTAL ASSESSMENT	
			LF	LF	Cost	Cost	Cost	Cost	Factor*	Cost	Factor*	Cost	Factor*	Cost	Factor*	Cost	Factor*	Cost	Factor*	Cost		Factor*
0709-213-1713-3	MED TOMSA, STACILON 211 S. CARROLL ST MADISON WI	4018 Mineral Point Rd	255.00		170.00	\$255.00	185.00	\$740.00	0.00	\$0.00	0.00	\$0.00	0.5	255.00	\$2,295.00	0.5	\$0.00	1.00	\$1,025.00	1.00	\$1,025.00	\$6,445.00
0709-204-0801-4	WEINHOLD, CRAIG E 1231 DARTMOUTH RD MADISON WI	4101 Hillcrest Dr	117.30		140.00	\$210.00	145.00	\$580.00	0.00	\$0.00	0.00	\$0.00	0.5	107.00	\$963.00	0.5	\$0.00	1.00	\$1,025.00	1.00	\$1,025.00	\$3,658.00
0709-204-0816-1	SCHUTTA, ROBERT J 402 MONTECAL POINT RD MADISON WI	4102 Mineral Point Rd	65.00		190.00	\$285.00	185.00	\$740.00	0.00	\$0.00	0.00	\$0.00	0.5	65.00	\$585.00	0.5	\$0.00	0.00	\$0.00	0.00	\$0.00	\$1,860.00
0709-213-1601-8	RAEFA, KENNETH F & ANN M BADEY KAFA 201 WESTMORLAND BLVD MADISON WI	201 Westmorland Blvd	99.20		125.00	\$187.50	105.00	\$420.00	0.00	\$0.00	0.00	\$0.00	0.5	99.20	\$892.80	0.5	\$0.00	1.00	\$1,025.00	1.00	\$1,025.00	\$1,305.30
0709-213-1602-6	GENTILLI, S V & BELBY, J 207 WESTMORLAND BLVD MADISON WI	207 Westmorland Blvd	70.00		125.00	\$187.50	100.00	\$400.00	0.00	\$0.00	0.00	\$0.00	1	70.00	\$1,260.00	1	\$0.00	1.00	\$1,025.00	1.00	\$1,025.00	\$4,002.50
0709-204-0833-5	HALDERMAN, DALE A & CHANDA M HALDERMAN 208 WESTMORLAND BLVD MADISON WI	208 Westmorland Blvd	60.00		100.00	\$150.00	100.00	\$400.00	0.00	\$0.00	0.00	\$0.00	1	60.00	\$1,080.00	1	\$0.00	1.00	\$1,025.00	1.00	\$1,025.00	\$3,785.00
0709-204-0832-7	HACKNEY, JOHN M 212 WESTMORLAND BLVD MADISON WI	212 Westmorland Blvd	60.00		95.00	\$142.50	95.00	\$380.00	0.00	\$0.00	0.00	\$0.00	1	60.00	\$1,080.00	1	\$0.00	1.00	\$1,025.00	1.00	\$1,025.00	\$3,757.50
0709-213-1603-4	LEWENSE, SAMUEL GINA LEWENSE 113 WESTMORLAND BLVD MADISON WI	213 Westmorland Blvd	70.00		130.00	\$195.00	95.00	\$380.00	0.00	\$0.00	0.00	\$0.00	1	70.00	\$1,260.00	1	\$0.00	1.00	\$1,025.00	1.00	\$1,025.00	\$4,065.00
0709-204-0815-9	DAVIS, PETER O 216 WESTMORLAND BLVD MADISON WI	216 Westmorland Blvd	60.00		90.00	\$135.00	95.00	\$380.00	0.00	\$0.00	0.00	\$0.00	1	60.00	\$1,080.00	1	\$0.00	1.00	\$1,025.00	1.00	\$1,025.00	\$3,750.00
0709-213-1604-2	DOS ESCHAL, STEPHANIE J 209 WESTMORLAND BLVD MADISON WI	219 Westmorland Blvd	69.90		115.00	\$172.50	105.00	\$420.00	0.00	\$0.00	0.00	\$0.00	1	69.90	\$1,258.20	1	\$0.00	1.00	\$1,025.00	1.00	\$1,025.00	\$4,005.70
0709-204-0830-1	ROACH, JAMES C & HEATHER W ROACH 220 WESTMORLAND BLVD MADISON WI	220 Westmorland Blvd	60.00		90.00	\$135.00	90.00	\$360.00	0.00	\$0.00	0.00	\$0.00	1	60.00	\$1,080.00	1	\$0.00	1.00	\$1,025.00	1.00	\$1,025.00	\$3,772.00
0709-204-0849-4	DOHERTY, THOMAS E & ANASTASIA DOHERTY 224 WESTMORLAND BLVD MADISON WI	224 Westmorland Blvd	60.00		85.00	\$127.50	90.00	\$360.00	0.00	\$0.00	0.00	\$0.00	1	60.00	\$1,080.00	1	\$0.00	1.00	\$1,025.00	1.00	\$1,025.00	\$3,806.50
0709-213-1605-0	NAWROCKI, KELLY 225 WESTMORLAND BLVD MADISON WI	225 Westmorland Blvd	69.00		115.00	\$172.50	115.00	\$460.00	0.00	\$0.00	0.00	\$0.00	1	69.00	\$1,242.00	1	\$0.00	1.00	\$1,025.00	1.00	\$1,025.00	\$4,020.50
0709-204-0848-6	MICKSCH, PAUL W SONIA L MICKSCH 228 WESTMORLAND BLVD MADISON WI	228 Westmorland Blvd	60.00		80.00	\$120.00	80.00	\$320.00	0.00	\$0.00	0.00	\$0.00	1	60.00	\$1,080.00	1	\$0.00	1.00	\$1,025.00	1.00	\$1,025.00	\$3,750.00
0709-213-1606-8	LEPEK, LIKSA M 231 WESTMORLAND BLVD MADISON WI	231 Westmorland Blvd	71.00		110.00	\$165.00	100.00	\$400.00	0.00	\$0.00	0.00	\$0.00	1	71.00	\$1,278.00	1	\$0.00	1.00	\$1,025.00	1.00	\$1,025.00	\$3,998.00
0709-204-0847-8	IRWIN, DINNA 232 WESTMORLAND BLVD MADISON WI	232 Westmorland Blvd	60.00		105.00	\$157.50	100.00	\$400.00	0.00	\$0.00	0.00	\$0.00	1	60.00	\$1,080.00	1	\$0.00	1.00	\$1,025.00	1.00	\$1,025.00	\$3,665.50
0709-204-0846-0	EGGELER, JAMES L & BARBARA J REY 236 WESTMORLAND BLVD MADISON WI	236 Westmorland Blvd	54.00		90.00	\$135.00	95.00	\$380.00	0.00	\$0.00	0.00	\$0.00	1	54.00	\$972.00	1	\$0.00	1.00	\$1,025.00	1.00	\$1,025.00	\$3,792.00
0709-213-1607-6	SWENSON, CHERI A 237 WESTMORLAND BLVD MADISON WI	237 Westmorland Blvd	91.50 75.00		0.00	\$0.00	110.00	\$440.00	0.00	\$0.00	0.00	\$0.00	0.5	91.50	\$823.50	0.5	\$5.00	1.00	\$1,025.00	1.00	\$1,025.00	\$4,183.50
0709-204-0845-2	YDE, KATHERINE M RICHARD C YDE 302 WESTMORLAND BLVD MADISON WI	302 Westmorland Blvd	60.00		75.00	\$112.50	75.00	\$300.00	0.00	\$0.00	0.00	\$0.00	1	60.00	\$1,080.00	1	\$0.00	1.00	\$1,025.00	1.00	\$1,025.00	\$3,647.50
0709-204-0844-4	SCHERER, TELL MICHAEL DOBBS 306 WESTMORLAND BLVD MADISON WI	306 Westmorland Blvd	60.00		60.00	\$90.00	95.00	\$380.00	0.00	\$0.00	0.00	\$0.00	1	60.00	\$1,080.00	1	\$0.00	1.00	\$1,025.00	1.00	\$1,025.00	\$3,709.00
0709-213-1711-5	MACDONALD ET AL., SARAH E 309 WESTMORLAND BLVD MADISON WI	309 Westmorland Blvd	115.90 96.00		0.00	\$0.00	115.00	\$460.00	0.00	\$0.00	0.00	\$0.00	0.5	115.90	\$1,040.10	0.5	\$0.00	1.00	\$1,025.00	1.00	\$1,025.00	\$1,147.10

\*A factor has been applied for sidewalk and curb and gutter work adjacent to lots that abut more than one street and are single-family or two-family residential dwellings.

0709-204-0843-6 TR-C1	RASULUSSEN, MEGAN ANN 310 WESTMORLAND BLVD MADISON WI	310 Westmorland Blvd	60.00	0.00	\$0.00	1	10.00	100.00	110.00	\$525.00	1	60.00	\$1,080.00	1	0.00	\$0.00	1.00	\$1,025.00	30.00	\$630.00	\$3,525.00
0709-204-0842-8 TR-C1	KLANK, TONY A 314 WESTMORLAND BLVD MADISON WI	314 Westmorland Blvd	60.00	52.50	\$78.75	1	0.00	100.00	100.00	\$500.00	1	60.00	\$1,080.00	1	0.00	\$0.00	1.00	\$1,025.00	30.00	\$630.00	\$3,613.75
0709-213-1712-3 TR-C1	GEBLEFF, BARBARA K 315 WESTMORLAND BLVD MADISON WI	315 Westmorland Blvd	82.00	0.00	\$0.00	1	0.00	0.00	0.00	\$0.00	1	82.00	\$1,476.00	1	0.00	\$0.00	1.00	\$1,025.00	30.00	\$630.00	\$3,651.00
0709-204-0841-0 TR-C1	BELD, DANIEL J 318 WESTMORLAND BLVD MADISON WI	318 Westmorland Blvd	60.00	52.50	\$78.75	1	5.00	100.00	105.00	\$525.00	1	60.00	\$1,080.00	1	0.00	\$0.00	1.00	\$1,025.00	30.00	\$630.00	\$3,668.75
0709-213-1713-1 TR-C1	KRUQ, PETER F LINDA D KRUG 321 WESTMORLAND BLVD MADISON WI	321 Westmorland Blvd	70.40	130.00	\$195.00	1	0.00	0.00	0.00	\$0.00	1	70.40	\$1,267.20	1	0.00	\$0.00	1.00	\$1,025.00	30.00	\$630.00	\$3,717.20
0709-204-0840-2 TR-C1	VAN VLACK, CHRISTOPHER T 322 WESTMORLAND BLVD MADISON WI	322 Westmorland Blvd	60.00	50.00	\$75.00	1	25.00	100.00	125.00	\$625.00	1	60.00	\$1,080.00	1	0.00	\$0.00	1.00	\$1,025.00	32.00	\$672.00	\$3,757.00
0709-213-1714-9 TR-C1	REYNARD REV TR, SUSAN E 325 WESTMORLAND BLVD MADISON WI	325 Westmorland Blvd	60.00	70.00	\$105.00	1	0.00	0.00	0.00	\$0.00	1	60.00	\$1,080.00	1	0.00	\$0.00	1.00	\$1,025.00	30.00	\$630.00	\$3,180.00
0709-204-0839-5 TR-C1	PIESSNER, JOHN P 1018 SERRA PINON SANTA FE, NM	326 Westmorland Blvd	60.00	55.00	\$82.50	1	5.00	100.00	105.00	\$525.00	1	60.00	\$1,080.00	1	0.00	\$0.00	1.00	\$1,025.00	30.00	\$630.00	\$3,622.50
0709-204-0838-7 TR-C1	BILLER, CHRISTOPHER L 130 WESTMORLAND BLVD MADISON WI	330 Westmorland Blvd	60.00	62.50	\$93.75	1	0.00	100.00	100.00	\$500.00	1	60.00	\$1,080.00	1	0.00	\$0.00	1.00	\$1,025.00	30.00	\$630.00	\$3,588.75
0709-204-0837-9 TR-C1	DILLON, MARY ANN 3013 BRICHALE MADISON WI	334 Westmorland Blvd	60.00	62.50	\$93.75	1	0.00	100.00	100.00	\$500.00	1	60.00	\$1,080.00	1	0.00	\$0.00	1.00	\$1,025.00	35.00	\$735.00	\$3,713.75
TOTALS			2,625.00	\$3,957.50	2,880.00	\$11,520.00	245.00	\$980.00	--	2,309.50	\$34,975.80	30.00	\$30,750.00	901.00	\$18,921.00	\$117,238.30					

\*A factor has been applied for sidewalk and curb and gutter work adjacent to lots that abut more than one street and are single-family or two-family residential dwellings.