

URBAN DESIGN COMMISSION APPLICATION UDC

City of Madison
 Planning Division
 Madison Municipal Building, Suite 017
 215 Martin Luther King, Jr. Blvd.
 P.O. Box 2985
 Madison, WI 53701-2985
 (608) 266-4635



FOR OFFICE USE ONLY:

Paid _____ Receipt # _____

Date received _____

Received by _____

Aldermanic District _____

Zoning District _____

Urban Design District _____

Submittal reviewed by _____

Legistar # _____

Complete all sections of this application, including the desired meeting date and the action requested.

If you need an interpreter, translator, materials in alternate formats or other accommodations to access these forms, please call the phone number above immediately.

1. Project Information

Address: 8549 and 8557 Elderberry

Title: 8549 and 8557 Elderberry

2. Application Type (check all that apply) and Requested Date

UDC meeting date requested October 2nd

New development Alteration to an existing or previously-approved development
 Informational Initial approval Final approval

3. Project Type

<input type="checkbox"/> Project in an Urban Design District <input type="checkbox"/> Project in the Downtown Core District (DC), Urban Mixed-Use District (UMX), or Mixed-Use Center District (MXC) <input type="checkbox"/> Project in the Suburban Employment Center District (SEC), Campus Institutional District (CI), or Employment Campus District (EC) <input checked="" type="checkbox"/> Planned Development (PD) <input type="checkbox"/> General Development Plan (GDP) <input checked="" type="checkbox"/> Specific Implementation Plan (SIP) <input type="checkbox"/> Planned Multi-Use Site or Residential Building Complex	Signage <input type="checkbox"/> Comprehensive Design Review (CDR) <input type="checkbox"/> Signage Variance (i.e. modification of signage height, area, and setback) Other <input type="checkbox"/> Please specify _____
--	---

4. Applicant, Agent, and Property Owner Information

Applicant name <u>James Hess</u> Street address <u>437 S. Yellowstone Dr. #201</u> Telephone <u>608-239-5812 608-213-0906</u>	Company <u>American Realtors</u> City/State/Zip <u>Madison WI 53719</u> Email <u>hessjamesb@gmail.com</u>
Project contact person <u>James Hess</u> Street address <u>437 S. Yellowstone Dr. #201</u> Telephone <u>608-239-5812 608-213-0906</u>	Company <u>American Realtors</u> City/State/Zip <u>Madison WI 53719</u> Email <u>hessjamesb@gmail.com</u>
Property owner (if not applicant) <u>Anand Santhalingam</u> Street address <u>810 Silver Sage Trail</u> Telephone <u>608-346-5668 608-316-1516</u>	City/State/Zip <u>Middleton WI 53562</u> Email <u>ananda.santhalingam@gmail.com</u>

Urban Design Commission Application (continued)



5. Required Submittal Materials

- Application Form**
- Letter of Intent**
 - If the project is within an Urban Design District, a summary of how the development proposal addresses the district criteria is required
 - For signage applications, a summary of how the proposed signage is consistent with the applicable CDR or Signage Variance review criteria is required.
- Development plans (Refer to checklist on Page 4 for plan details)**
- Filing fee**
- Electronic Submittal***

Each submittal must include fourteen (14) 11" x 17" collated paper copies. Landscape and Lighting plans (if required) must be full-sized and legible. Please refrain from using plastic covers or spiral binding.

Both the paper copies and electronic copies must be submitted prior to the application deadline before an application will be scheduled for a UDC meeting. Late materials will not be accepted. A completed application form is required for each UDC appearance.

For projects also requiring Plan Commission approval, applicants must also have submitted an accepted application for Plan Commission consideration prior to obtaining any formal action (initial or final approval) from the UDC. All plans must be legible when reduced.

**Electronic copies of all items submitted in hard copy are required. Individual PDF files of each item submitted should be compiled on a CD or flash drive, or submitted via email to udcapplications@cityofmadison.com. The email must include the project address, project name, and applicant name. Electronic submittals via file hosting services (such as Dropbox.com) are not allowed. Applicants who are unable to provide the materials electronically should contact the Planning Division at (608) 266-4635 for assistance.*

6. Applicant Declarations

1. Prior to submitting this application, the applicant is required to discuss the proposed project with Urban Design Commission staff. This application was discussed with Tim Parks, Jarine Glaesner and Jerry Krogstad on April 12 2019.
2. The applicant attests that all required materials are included in this submittal and understands that if any required information is not provided by the application deadline, the application will not be placed on an Urban Design Commission agenda for consideration.

Name of applicant James Hess Relationship to property Developer

Authorizing signature of property owner *Arund Santhalingam* Date 9/10/19

dotloop verified
09/10/19 6:02 PM CDT
M53P-TX4J-CD0X-G5DD

7. Application Filing Fees

Fees are required to be paid with the first application for either initial or final approval of a project, unless the project is part of the combined application process involving the Urban Design Commission in conjunction with Plan Commission and/or Common Council consideration. Make checks payable to City Treasurer. Credit cards may be used for application fees of less than \$1,000.

Please consult the schedule below for the appropriate fee for your request:

- Urban Design Districts: \$350 (per §35.24(6) MGO).
- Minor Alteration in the Downtown Core District (DC) or Urban Mixed-Use District (UMX) : \$150 (per §33.24(6)(b) MGO)
- Comprehensive Design Review: \$500 (per §31.041(3)(d)(1)(a) MGO)
- Minor Alteration to a Comprehensive Sign Plan: \$100 (per §31.041(3)(d)(1)(c) MGO)
- All other sign requests to the Urban Design Commission, including, but not limited to: appeals from the decisions of the Zoning Administrator, requests for signage variances (i.e. modifications of signage height, area, and setback), and additional sign code approvals: \$300 (per §31.041(3)(d)(2) MGO)

A filing fee is not required for the following project applications if part of the combined application process involving both Urban Design Commission and Plan Commission:

- Project in the Downtown Core District (DC), Urban Mixed-Use District (UMX), or Mixed-Use Center District (MXC)
- Project in the Suburban Employment Center District (SEC), Campus Institutional District (CI), or Employment Campus District (EC)
- Planned Development (PD): General Development Plan (GDP) and/or Specific Implementation Plan (SIP)
- Planned Multi-Use Site or Residential Building Complex

URBAN DESIGN COMMISSION APPROVAL PROCESS

UDC

Introduction

The City of Madison's Urban Design Commission (UDC) has been created to:

- Encourage and promote high quality in the design of new buildings, developments, remodeling, and additions so as to maintain and improve the established standards of property values within the City.
- Foster civic pride in the beauty and nobler assets of the City, and in all other ways possible assure a functionally efficient and visually attractive City in the future.

Types of Approvals

There are three types of requests considered by the UDC:

- **Informational Presentation.** Applicants may, at their discretion, request to make an Informational Presentation to the UDC prior to seeking any approvals to obtain early feedback and direction before undertaking detailed design. Applicants should provide details on the context of the site, design concept, site and building plans, and other relevant information to help the UDC understand the proposal and provide feedback. (Does not apply to CDR's or Signage Variance requests)
- **Initial Approval.** Applicants may, at their discretion, request initial approval of a proposal by presenting preliminary design information. As part of their review, the Commission will provide feedback on the design information that should be addressed at Final Approval stage.
- **Final Approval.** Applicants may request Final Approval of a proposal by presenting all final project details. Recommendations or concerns expressed by the UDC in the initial approval must be addressed at this time.

Presentations to the Commission

Primarily, the UDC is interested in the appearance and design quality of projects. Emphasis should be given to the site plan, landscape plan, lighting plan, building elevations, exterior building materials, color scheme, and graphics.

When presenting projects to the UDC, applicants must fill out a registration slip provided in the meeting room and present it to the Secretary. Presentations should generally be limited to 5 minutes or as extended by motion by consent of the Commission. The Commission will withhold questions until the end of the presentation.

Applicants are encouraged to consider the use of various graphic presentation material including a locator map, photographs, renderings/model, scale drawings of the proposal in context with adjacent buildings/uses/signs, etc., as may be deemed appropriate to describe the project and its surroundings. Graphics should be mounted on rigid boards so that they may be easily displayed. **Applicants/presenters are responsible for all presentation materials, AV equipment and easels.**

URBAN DESIGN DEVELOPMENT PLANS CHECKLIST

UDC

The items listed below are minimal application requirements for the type of approval indicated. Please note that the UDC and/or staff may require additional information in order to have a complete understanding of the project.

1. Informational Presentation

- Locator Map
- Letter of Intent (If the project is within an Urban Design District, a summary of how the development proposal addresses the district criteria is required)
- Contextual site information, including photographs and layout of adjacent buildings/structures
- Site Plan
- Two-dimensional (2D) images of proposed buildings or structures.

Providing additional information beyond these minimums may generate a greater level of feedback from the Commission.

Requirements for All Plan Sheets

1. Title block
2. Sheet number
3. North arrow
4. Scale, both written and graphic
5. Date
6. Fully dimensioned plans, scaled at 1"= 40' or larger

**** All plans must be legible, including the full-sized landscape and lighting plans (if required)**

2. Initial Approval

- Locator Map
- Letter of Intent (If the project is within a Urban Design District, a summary of how the development proposal addresses the district criteria is required)
- Contextual site information, including photographs and layout of adjacent buildings/structures
- Site Plan showing location of existing and proposed buildings, walks, drives, bike lanes, bike parking, and existing trees over 18" diameter
- Landscape Plan and Plant List (*must be legible*)
- Building Elevations in both black & white and color for all building sides (include material callouts)
- PD text and Letter of Intent (if applicable)

Providing additional information beyond these minimums may generate a greater level of feedback from the Commission.

3. Final Approval

All the requirements of the Initial Approval (see above), **plus:**

- Grading Plan
- Proposed Signage (if applicable)
- Lighting Plan, including fixture cut sheets and photometrics plan (*must be legible*)
- Utility/HVAC equipment location and screening details (with a rooftop plan if roof-mounted)
- PD text and Letter of Intent (if applicable)
- Samples of the exterior building materials (presented at the UDC meeting)

4. Comprehensive Design Review (CDR) and Variance Requests (*Signage applications only*)

- Locator Map
- Letter of Intent (a summary of how the proposed signage is consistent with the CDR or Signage Variance criteria is required)
- Contextual site information, including photographs of existing signage both on site and within proximity to the project site
- Site Plan showing the location of existing signage and proposed signage, dimensioned signage setbacks, sidewalks, driveways, and right-of-ways
- Proposed signage graphics (fully dimensioned, scaled drawings, including materials and colors, and night view)
- Perspective renderings (emphasis on pedestrian/automobile scale viewsheds)
- Illustration of the proposed signage that meets Ch. 31, MGO compared to what is being requested.
- Graphic of the proposed signage as it relates to what the Ch. 31, MGO would permit

Urban Design Commission Revised S.I.P. Resubmission - Letter of Intent
DUPLEX HOUSING
8549 & 8557 Elderberry Road
Madison, Wisconsin
Dimension IV Project No. 19014
September 11, 2019

1. Project Team

Applicant: American Realtors
Attention: James Hess
437 S. Yellowstone Drive #201
Madison, Wisconsin 53719
Phone: 608.239.5812
Email: hessjamesb@gmail.com

Land Owner: Anand Santhalingam
810 Silver Sage Trail
Middleton, Wisconsin 53562
Phone: 608.346.5668
Email: anand.santhalingam@gmail.com

Architect: Dimension IV Madison Design Group
Jerry Bourquin
6515 Grand Teton Plaza, Suite 120
Madison, Wisconsin 53719
Phone: 608.829.4452
Email: jbouquin@dimensionivmadison.com

Civil Engineer/Site Design: Snyder & Associates, Inc.
Mike Calkins
5010 Voges Road
Madison, Wisconsin 53718
Phone: 608-838-0444
Email: mcalkins@snyder-associates.com

Landscape Architect: Herman Landscape
Jerry Opime
6606 Seybold Road
Madison Wisconsin 53744
Phone: 608-288-9400
Email: Jerry@hermanlandscape.com

6515 Grand Teton Plaza, Suite 120
Madison, Wisconsin 53719
p 608.829.4444
f 608.829.4445

2. Existing Conditions

The site is two existing vacant lots.

3. Project Schedule

Upon securing agency and financing approvals, the project is scheduled to start construction in summer of 2019 with occupancy in fall/winter 2020.

4. Proposed Uses

The project is two duplex lots. A duplex will be developed on each lot.

5. Hours of Operation

Not applicable.

6. Building Square Footage

	Lot 1 (8549) Building A	Lot 2 (8557) Building B	Total
Basement Level	1,948 square feet	1,948 square feet	3,896 square feet
First Level:	1,948 square feet	1,948 square feet	3,896 square feet
Second Level:	<u>2,130 square feet</u>	<u>2,130 square feet</u>	<u>4,260 square feet</u>
TOTAL	6,026 square feet	6,026 square feet	12,052 square feet

7. Number of Dwelling Units: Two, 3-bedroom units per lot.

8. Auto and Bike Parking Stalls: A two-car garage is provided for each unit.

9. Lot Data

Zoning: Planned development General Development Plan (GDP) for two duplex lots. Lots to be rezoned to Specific Implementation Plan (SIP) for two duplex lots.

Lot Size: Lot 1 – 11,961 square feet Lot 2 – 15,515 Total – 27,476 square feet

Lot Coverage

	Lot 1 (8549)	Lot 2 (8557)	Total
Building	2,850 square feet (24%)	2,850 square feet (19%)	5,700 sf (21%)
Impervious Area	1,686 square feet (14%)	2,357 square feet (15%)	4,043 sf (15%)
Pervious Area	<u>7,425 square feet (62%)</u>	<u>10,308 square feet (66%)</u>	<u>17,733 sf (64%)</u>
TOTAL	11,961 square feet (100%)	15,515 square feet (100%)	27,476 sf (100%)

10. Usable Open Space: Not applicable

11. Land Value: Not Applicable

12. Estimated Project Cost: Not Applicable

13. Number of Construction or Full Time Equivalent Jobs Created: Not Applicable

14. Public Subsidy Requested: None

September 11, 2019

Ms. Janine Glaeser
Urban Design Commission
Madison Municipal Building, Suite 017
215 Martin Luther King Jr. Boulevard
P. O. Box 2985
Madison, Wisconsin 53703

Reference: 8549 & 8557 Elderberry Duplex Housing
Final Approval Submission

Dear Ms. Glaeser:

Attached is the application for final Urban Design Commission approval for the 8549 and 8557 Elderberry Road duplexes.

Per the review comments from the urban plan approval, we have incorporated the following revisions:

1. The building floor plans were revised to locate the bedrooms at the outside corner of the floor plan. The closets and bathrooms were pulled into the interior areas.
2. The jogs in the floor plan were reduced to simplify the exterior walls.
3. Windows were added in the bathrooms and bedrooms. Blank wall areas were reduced.
4. The roof lines were simplified to reduce the amount of gables. Shed roofs were incorporated into the roof.
5. Window heads were aligned to develop a more unified appearance.
6. The building exterior materials and color pallets were simplified to have fewer colors and materials.
7. The white roof edge has been revised to blend in with the adjacent roof colors.
8. The landscape plan has been revised to eliminate the Burning Bush and Gold Flame Spirea. More substantial shade trees were added in the back.

Let us know if you have any questions that we can answer prior to the meeting. Thank you.

Sincerely,

DIMENSION IV MADISON DESIGN GROUP

Jerry Bourquin, AIA
Principal

Enclosures: 14 applications
14 cover letters
14 plan review sets
14 copies of August 14, 2019 review letter

6515 Grand Teton Plaza, Suite 120
Madison, Wisconsin 53719

p 608.829.4444

f 608.829.4445

ELDERBERRY DUPLEXES - 8549 & 8557 ELDERBERRY ROAD

REVISED S.I.P. SUBMITTAL - URBAN DESIGN FINAL APPROVAL



PROJECT/BUILDING DATA

TWO NEW DUPLEX WOOD FRAME BUILDINGS

BUILDING AREAS

DUPLEX A: TOTAL BUILDING AREA = 6,026 SQFT
 BASEMENT FLOOR TOTAL AREA = 1,948 SQFT
 FIRST FLOOR TOTAL AREA = 1,948 SQFT
 SECOND FLOOR TOTAL AREA = 2,130 SQFT

DUPLEX B: TOTAL BUILDING AREA = 6,026 SQFT
 BASEMENT FLOOR TOTAL AREA = 1,948 SQFT
 FIRST FLOOR TOTAL AREA = 1,948 SQFT
 SECOND FLOOR TOTAL AREA = 2,130 SQFT

UNIT COUNT

TOTAL UNITS DUPLEX A:
 (2) 3BR UNITS
 TOTAL UNITS DUPLEX B:
 (2) 3BR UNITS

SHEET INDEX

- G1.0 COVER SHEET
- G2.0 CONTEXTUAL SITE INFORMATION
- G2.1 CONTEXTUAL SITE INFORMATION
- G2.2 NEIGHBORHOOD VISUAL CONTEXT
- G3.0 SURVEY MAP
- C1.0 EXISTING SITE PLAN
- C2.0 SITE PLAN
- C3.0 GRADING & EROSION CONTROL
- C4.0 UTILITY PLAN
- C5.0 INFILTRATION BASIN DETAIL SHEET
- C6.0 EROSION CONTROL NOTES & DETAILS
- C7.0 EROSION CONTROL DETAILS
- C8.0 MISC. DETAILS
- C9.0 UP-FLO FILTER DETAIL
- L1.0 LANDSCAPE PLAN AND PLANTING SCHEDULE
- A1.0 FLOOR PLANS - DUPLEX A (8549)
- A1.1 FLOOR PLANS - DUPLEX B (8557)
- A2.0 EXTERIOR ELEVATIONS - DUPLEX A (8549) - COLOR
- A2.1 EXTERIOR ELEVATIONS - DUPLEX A (8549) - BLACK & WHITE
- A2.2 EXTERIOR ELEVATIONS - DUPLEX B (8557) - COLOR
- A2.3 EXTERIOR ELEVATIONS - DUPLEX B (8557) - BLACK & WHITE
- A2.4 EXTERIOR VIEWS
- A2.5 EXTERIOR FINISH PALETTE



LOCATION MAP



PROJECT LOCATION



PHOTO 1 - LOOKING EAST



PHOTO 2 - LOOKING SOUTH



PHOTO 3 - LOOKING SOUTH WEST



PHOTO 4 - LOOKING NORTH



PHOTO 5 - LOOKING EAST

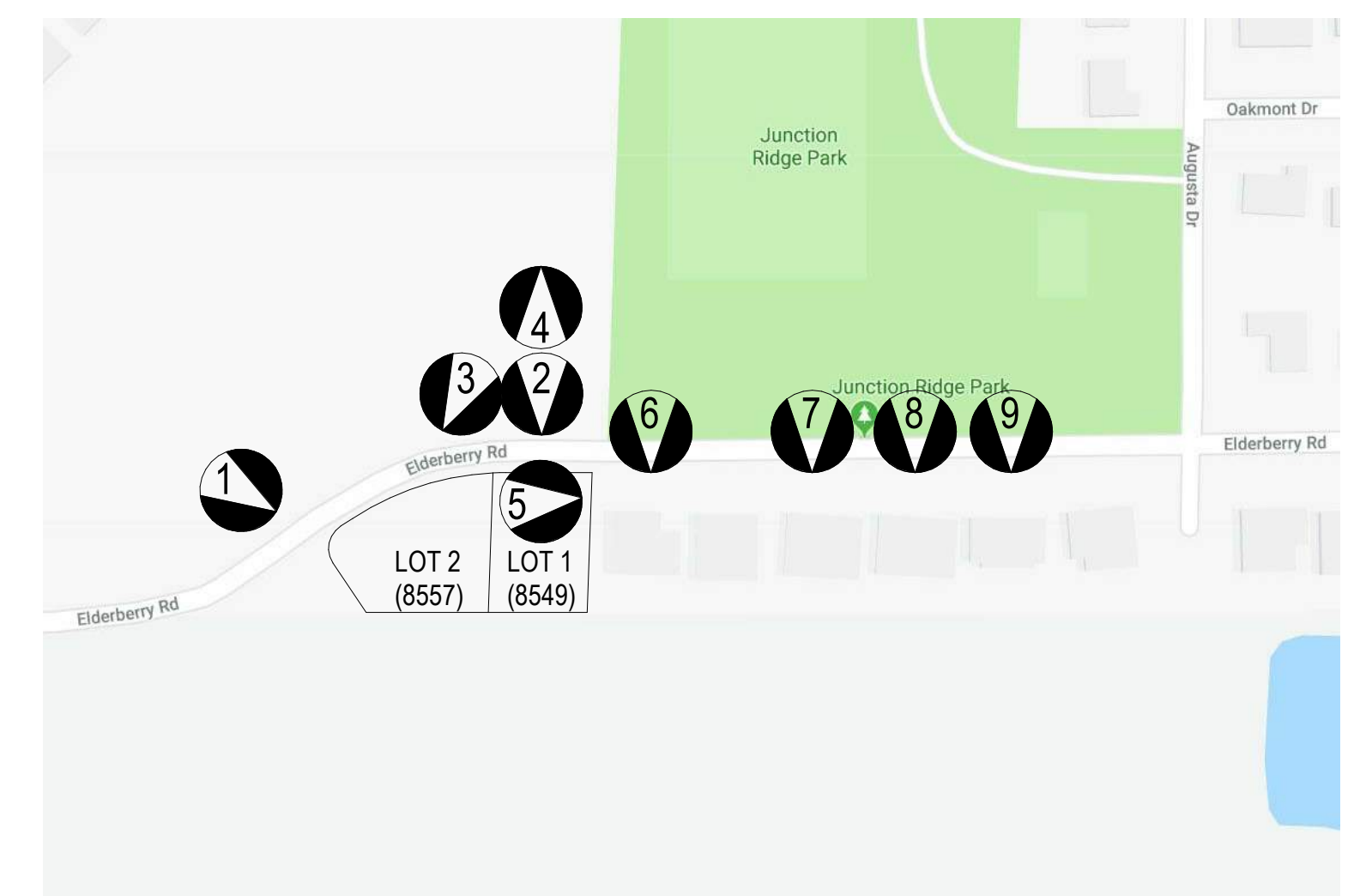

CONTEXTUAL SITE MAP 



PHOTO 6 - 8543 ELDERBERRY RD
(LOT TO THE EAST LOT 1 (8549 ELDERBERRY RD))



PHOTO 7 - 8527 ELDERBERRY RD



PHOTO 8 - 8517 ELDERBERRY RD



PHOTO 9 - 8511 ELDERBERRY RD

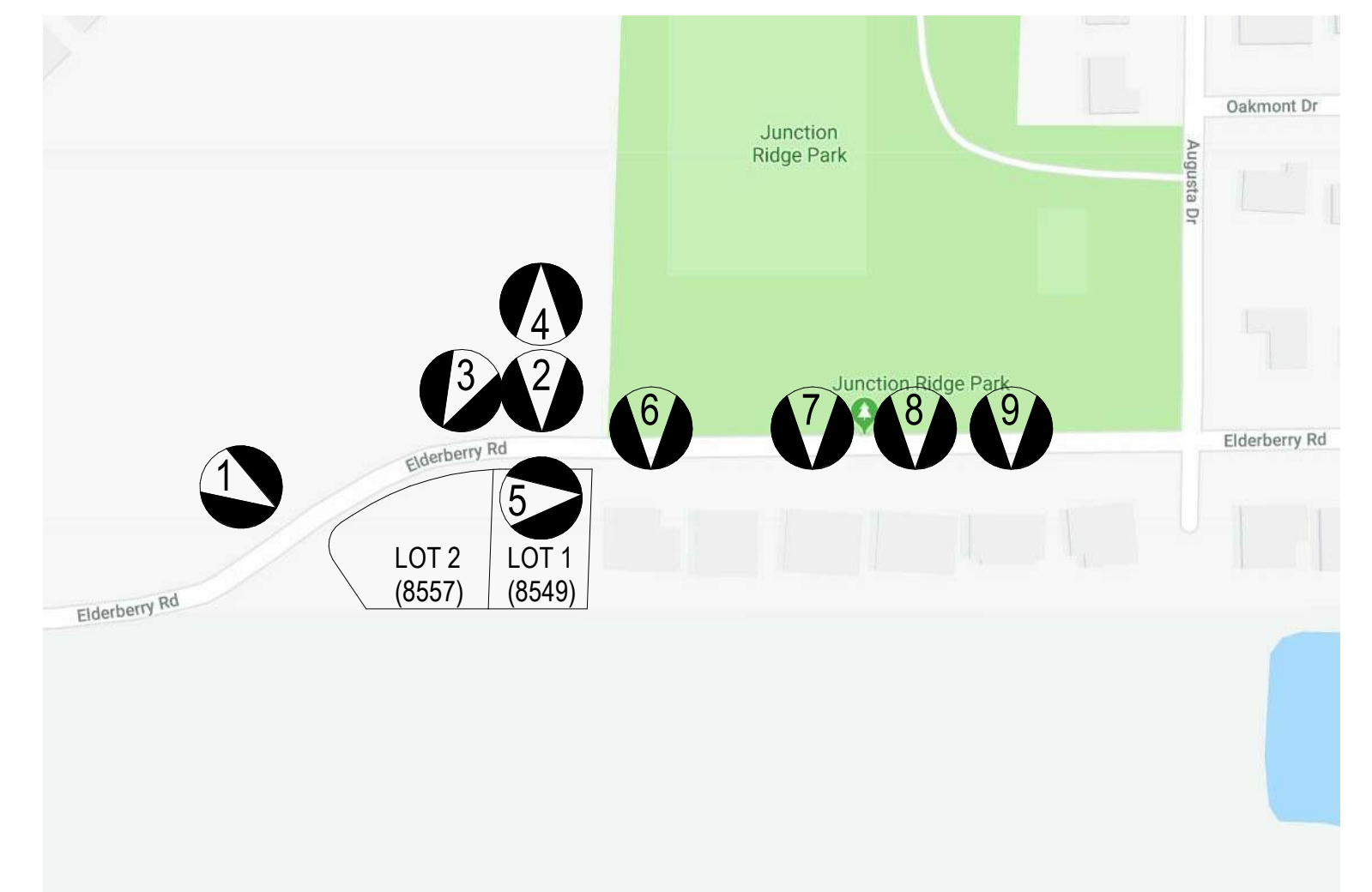

CONTEXTUAL SITE MAP 



NEIGHBORHOOD CONTEXT

G2.2

ELDERBERRY DUPLEXES

CERTIFIED SURVEY MAP No. 14370

ALL OF OUTLOT 5, PRAIRIE POINT, AS RECORDED IN VOLUME 57-184B OF PLATS, ON PAGES 769-770, AS DOCUMENT NUMBER 3371965, DANE COUNTY REGISTRY, LOCATED IN THE SOUTHEAST QUARTER OF THE NORTHWEST QUARTER OF SECTION 22, TOWNSHIP 07 NORTH, RANGE 08 EAST, CITY OF MADISON, DANE COUNTY, WISCONSIN.

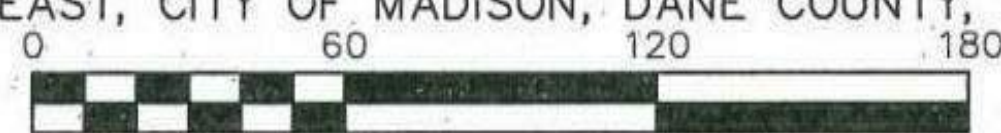

SCALE : ONE INCH = SIXTY FEET

Revised: 10/25/2016 mxB

FOUND ALUMINUM CAP MONUMENT AT THE NORTH QUARTER CORNER OF SECTION 22-07-08
N: 482918.57(482918.57)
E: 781642.54(781642.54)

CURVE TABLE

NUMBER	ARC LENGTH	CENTRAL ANGLE	RADIUS	CHORD DIRECTION	CHORD LENGTH
C1	29.06	04°53'51"	340.00	N58°50'50"E (S58°27'02.5"W)	29.05
C2	149.35	32°54'47"	260.00	N72°51'18"E (S72°27'30.5"W)	147.31
C3	137.42	30°16'55"	260.00	N71°32'22"E	135.82
C4	11.94	02°37'52"	260.00	N87°59'45"E	11.94
C5	39.27	90°00'00"	25.00	N11°23'54"E	35.36

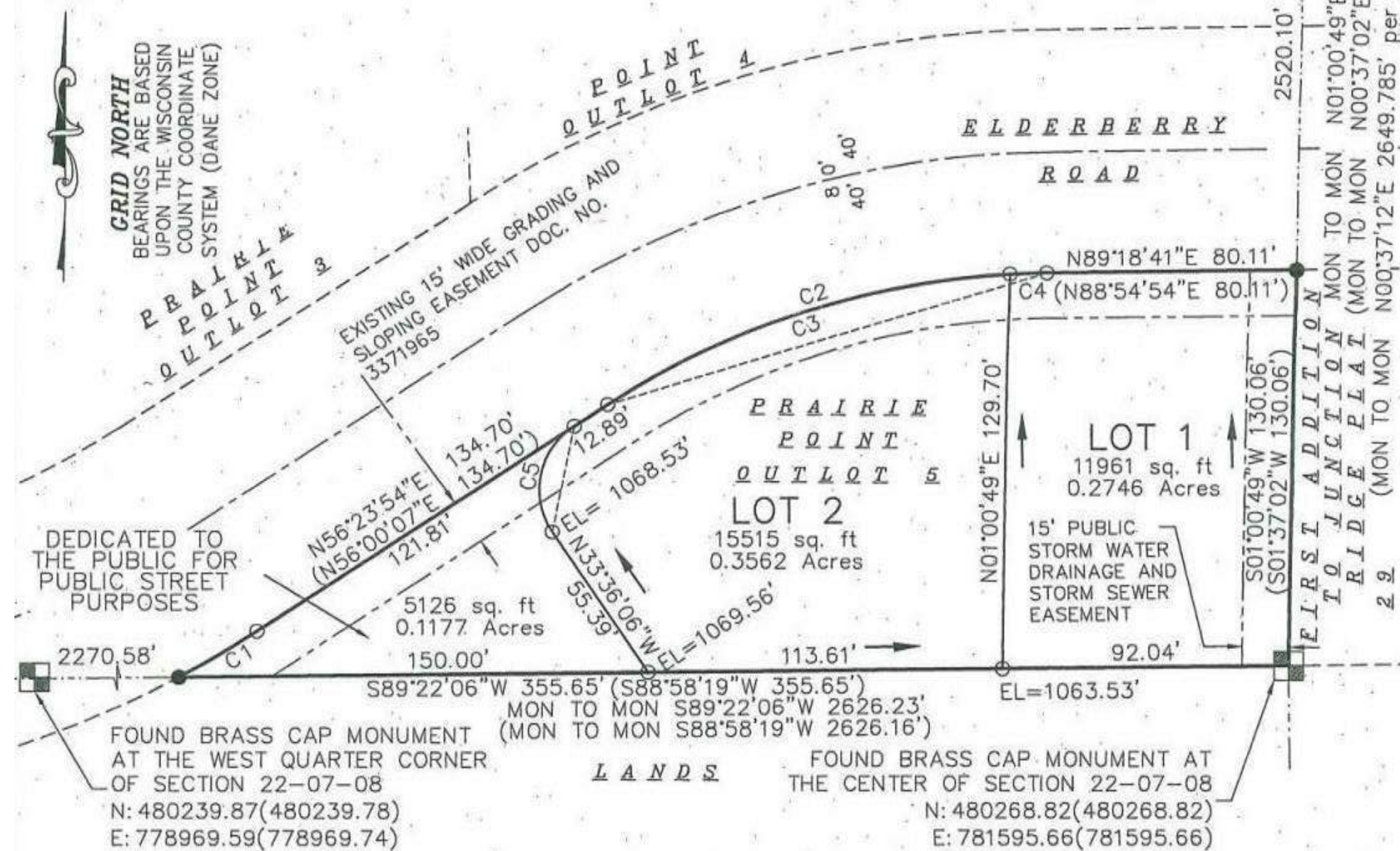

SURVEYED FOR :
ATTIC ANGEL PRAIRIE POINT INC

SURVEYED BY :
Burse
surveying & engineering llc
2801 International Lane, Suite 101
Madison, WI 53704 608.250.9263
Fax: 608.250.9266
email: mburse@bse-inc.net
www.bursesurveyengr.com

MAP NO. 14370
DOCUMENT NO. 5279650
VOLUME 98 PAGES 166
Date: 06-08-2016 RVSD: 10-25-2016
Plot View: CSM
RSF189\2016_CSM\DWG\RSF189CSM.DWG

- NOTES:
- 1) SEE SHEET 2 FOR LEGEND
 - 2) ALL LOTS CREATED BY THIS CERTIFIED SURVEY MAP ARE INDIVIDUALLY RESPONSIBLE FOR COMPLIANCE WITH CHAPTER 37 OF THE MADISON GENERAL ORDINANCE IN REGARD TO STORMWATER MANAGEMENT AT THE TIME THEY DEVELOP.
 - 3) LOTS WITHIN THE SUBDIVISION ARE SUBJECT TO IMPACT FEES THAT ARE DUE AND PAYABLE AT THE TIME BUILDING PERMIT(S) ARE ISSUED.
 - 4) SEE SHEET 4 FOR CITY OF MADISON NOTES.

SHEET 1 OF 4



architecture · interior design · planning
6515 Grand Teton Plaza, Suite 120, Madison, Wisconsin 53719
p608.829.4444 f608.829.4445 dimensionivmadison.com

G3.0

ELDERBERRY DUPLEXES

8549 & 8557 ELDERBERRY RD. MADISON WI

SURVEY MAP
09/11/2019
19014

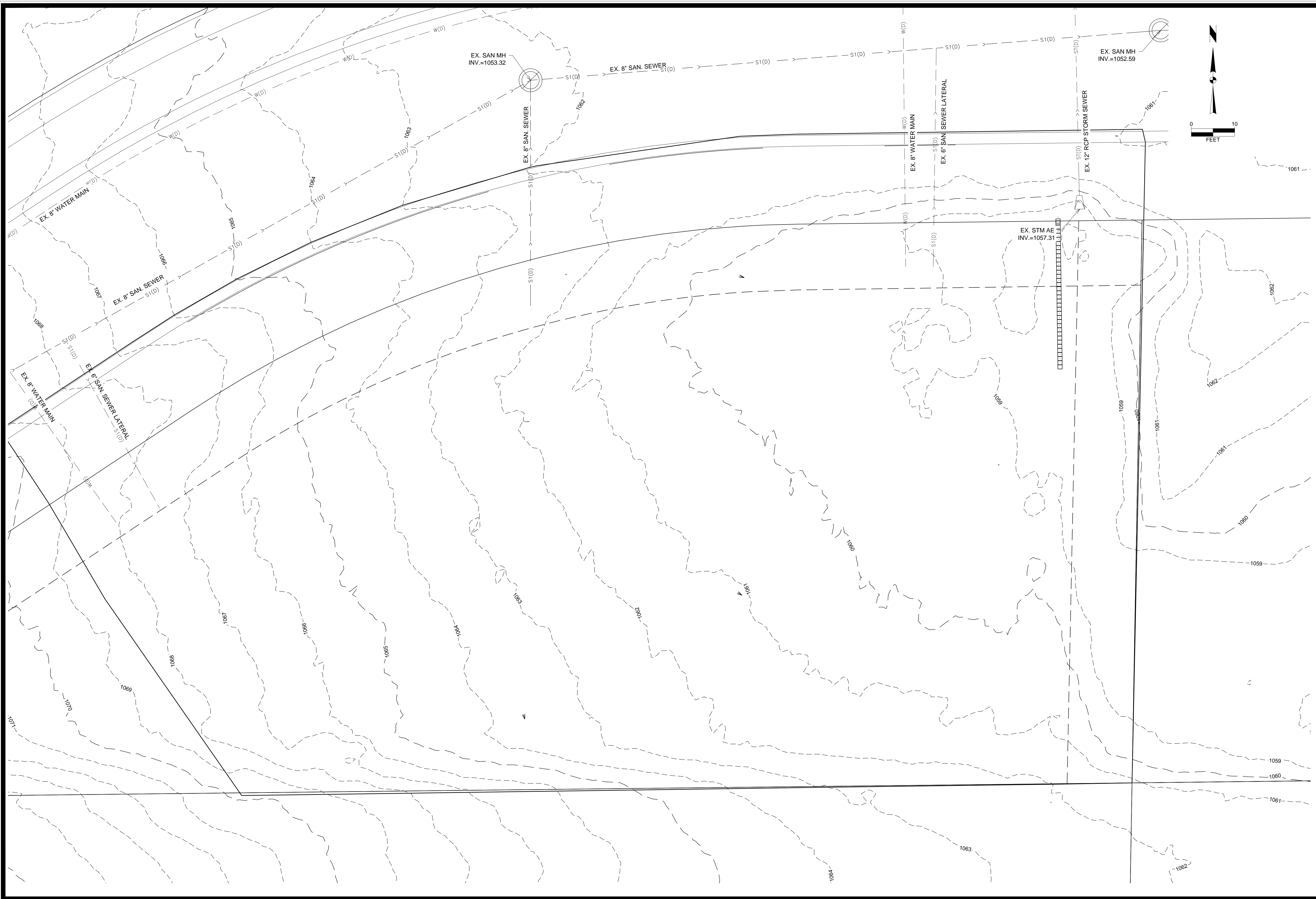

MARK	REVISION	DATE	BY

Engineer: BCA
 Checked By: MLC
 Date: 06-26-2019
 Technician: BCA
 Scale: 1" = AS SHOWN
 T-R-S: TTN-RRW-SS
 Project No: 119.0587.30
 Sheet C 1.0

8549 & 8557 ELDERBERRY ROAD
EXISTING SITE PLAN
MADISON, DANE COUNTY, WI
SNYDER & ASSOCIATES, INC.
 2727 S.W. SNYDER BLVD
 ANKENY, IOWA 50023
 515-984-2020 | www.snyder-associates.com

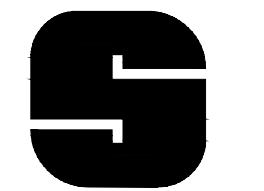

SNYDER & ASSOCIATES
 Project No: 119.0587.30
 Sheet C 1.0

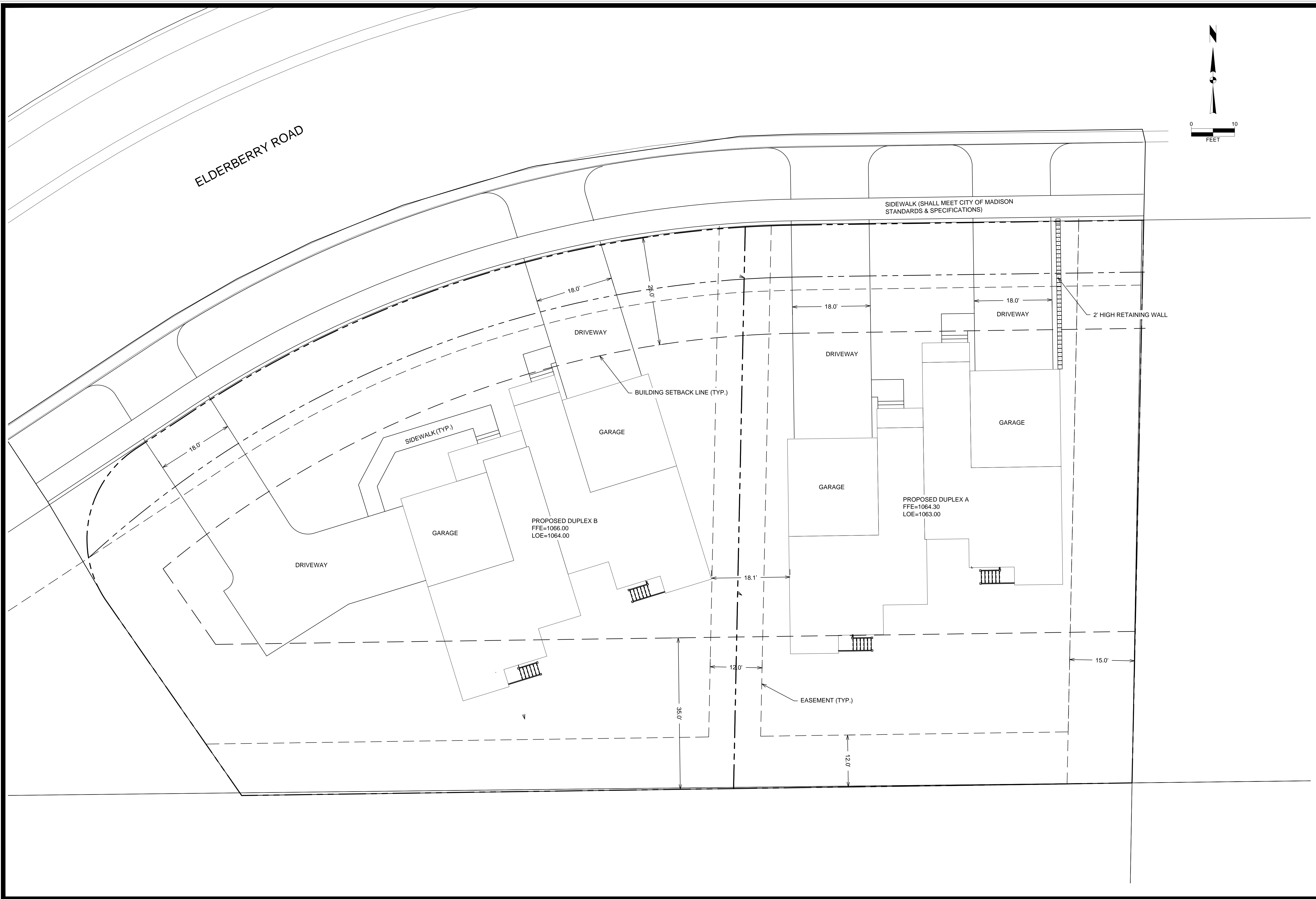

ELDERBERRY ROAD

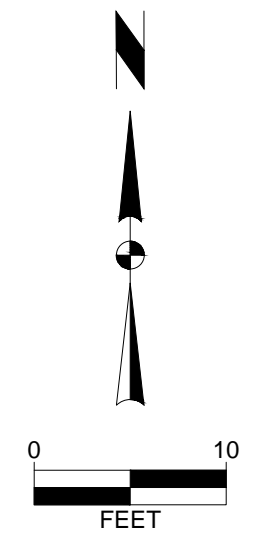

SIDEWALK (SHALL MEET CITY OF MADISON STANDARDS & SPECIFICATIONS)

2' HIGH RETAINING WALL

PROPOSED DUPLEX B
FFE=1066.00
LOE=1064.00

PROPOSED DUPLEX A
FFE=1064.30
LOE=1063.00

MARK	REVISION	DATE	BY
Engineer: BCA	Checked By: MLC	Date: 06-26-2019	Scale: 1" = AS SHOWN
Technician: BCA	Date: 06-26-2019	T-R-S: TTN-RRW-SS	Project No: 119.0587.30
			Sheet C 2.0

8549 & 8557 ELDERBERRY ROAD

MADISON, DANE COUNTY, WI

SITE PLAN

SNYDER & ASSOCIATES, INC.

2727 S.W. SNYDER BLVD
ANKENY, IOWA 50023
515-984-2020 | www.snyder-associates.com



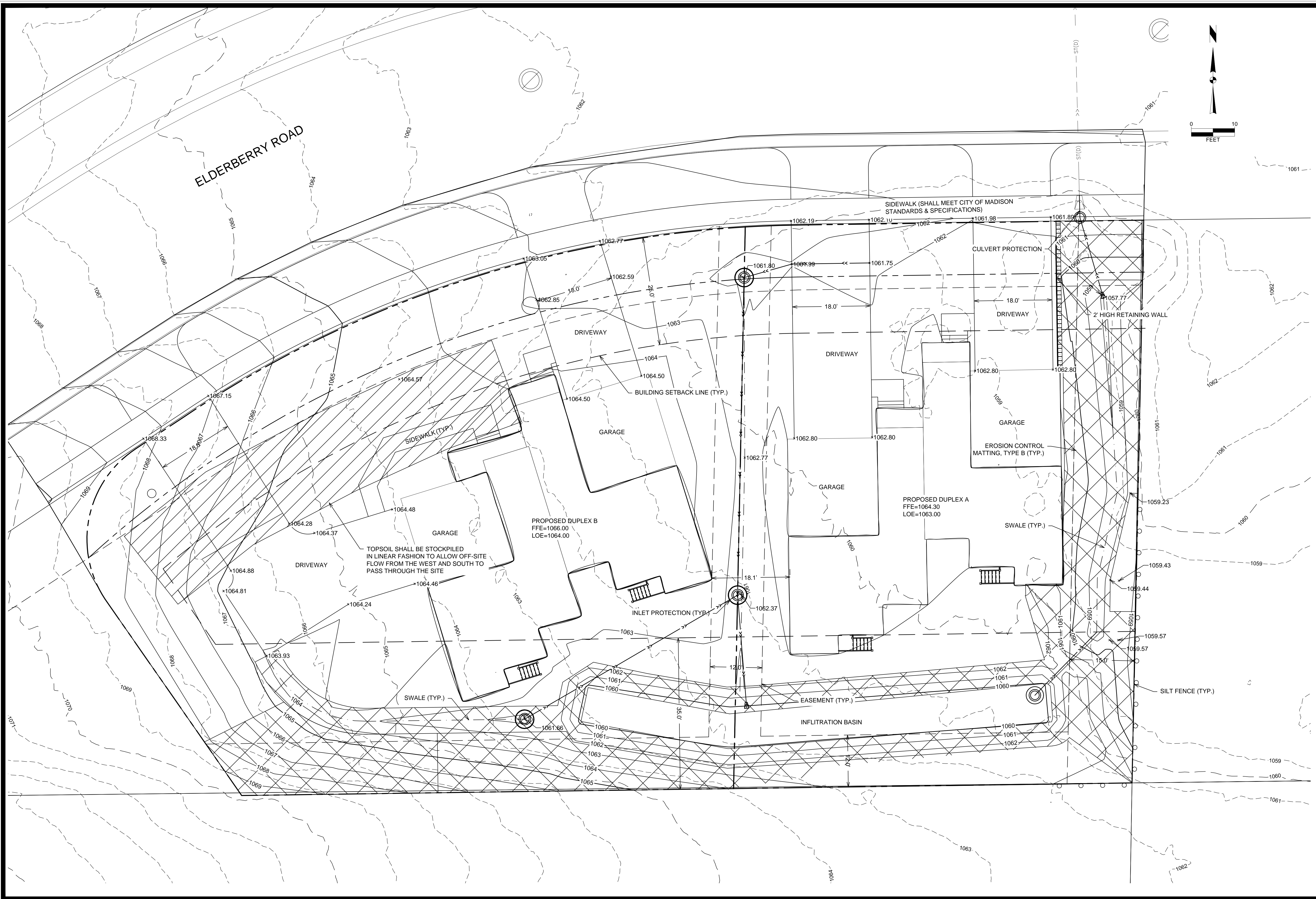

ELDERBERRY ROAD

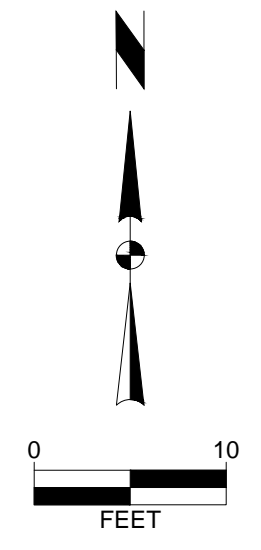

MARK	REVISION	DATE	BY
Engineer: BCA	Checked By: MLC	Date: 06-26-2019	Scale: 1" = AS SHOWN
Technician: BCA			T-R-S: TTN-RRW-SS
Project No: 119.0587.30			Sheet C 3.0

8549 & 8557 ELDERBERRY ROAD
GRADING & EROSION CONTROL
MADISON, DANE COUNTY, WI
SNYDER & ASSOCIATES, INC.
 2727 S.W. SNYDER BLVD
 ANKENY, IOWA 50023
 515-964-2020 | www.snyder-associates.com



Project No: 119.0587.30
 Sheet C 3.0

TOPSOIL SHALL BE STOCKPILED IN LINEAR FASHION TO ALLOW OFF-SITE FLOW FROM THE WEST AND SOUTH TO PASS THROUGH THE SITE

PROPOSED DUPLEX A
 FFE=1064.30
 LOE=1063.00

PROPOSED DUPLEX B
 FFE=1066.00
 LOE=1064.00

SIDEWALK (SHALL MEET CITY OF MADISON STANDARDS & SPECIFICATIONS)

2' HIGH RETAINING WALL

EROSION CONTROL MATTING, TYPE B (TYP.)

INFILTRATION BASIN

SILT FENCE (TYP.)

EASEMENT (TYP.)

INLET PROTECTION (TYP.)

SWALE (TYP.)

SWALE (TYP.)

GARAGE

GARAGE

GARAGE

GARAGE

DRIVEWAY

DRIVEWAY

DRIVEWAY

DRIVEWAY

SIDEWALK (TYP.)

BUILDING SETBACK LINE (TYP.)

CULVERT PROTECTION

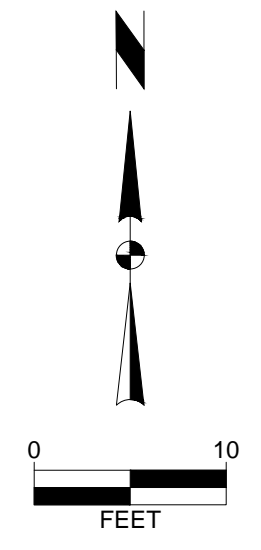
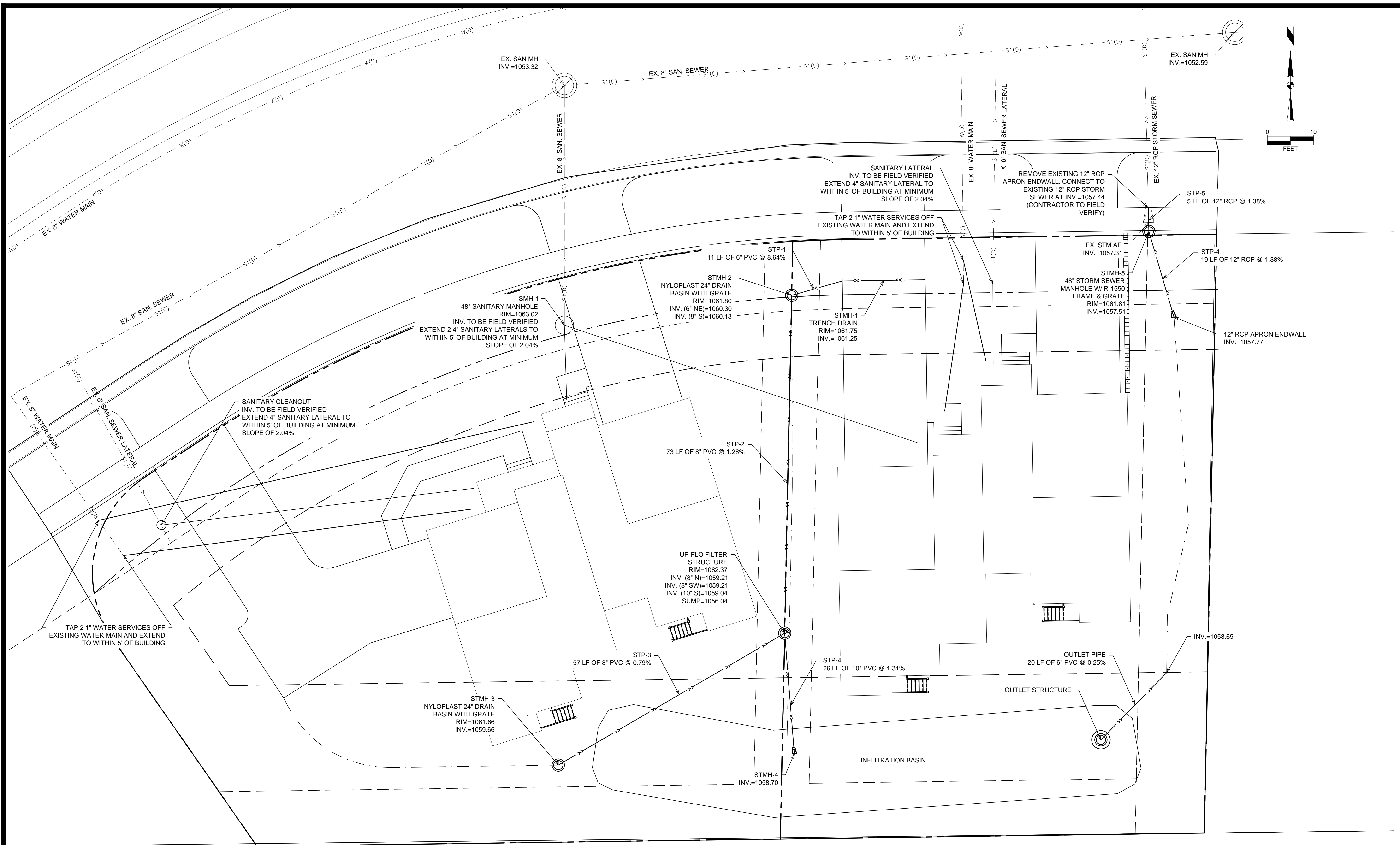

MARK	REVISION	DATE	BY
Engineer: BCA	Checked By: MLC	Date: 06-26-2019	Scale: 1" = AS SHOWN
Technician: BCA			T-R-S: TTN-RRW-SS
Project No: 119.0587.30			Sheet C 4.0

8549 & 8557 ELDERBERRY ROAD

UTILITY PLAN

MADISON, DANE COUNTY, WI

SNYDER & ASSOCIATES, INC.

2727 S.W. SNYDER BLVD
 ANKENY, IOWA 50023
 515-964-2020 | www.snyder-associates.com



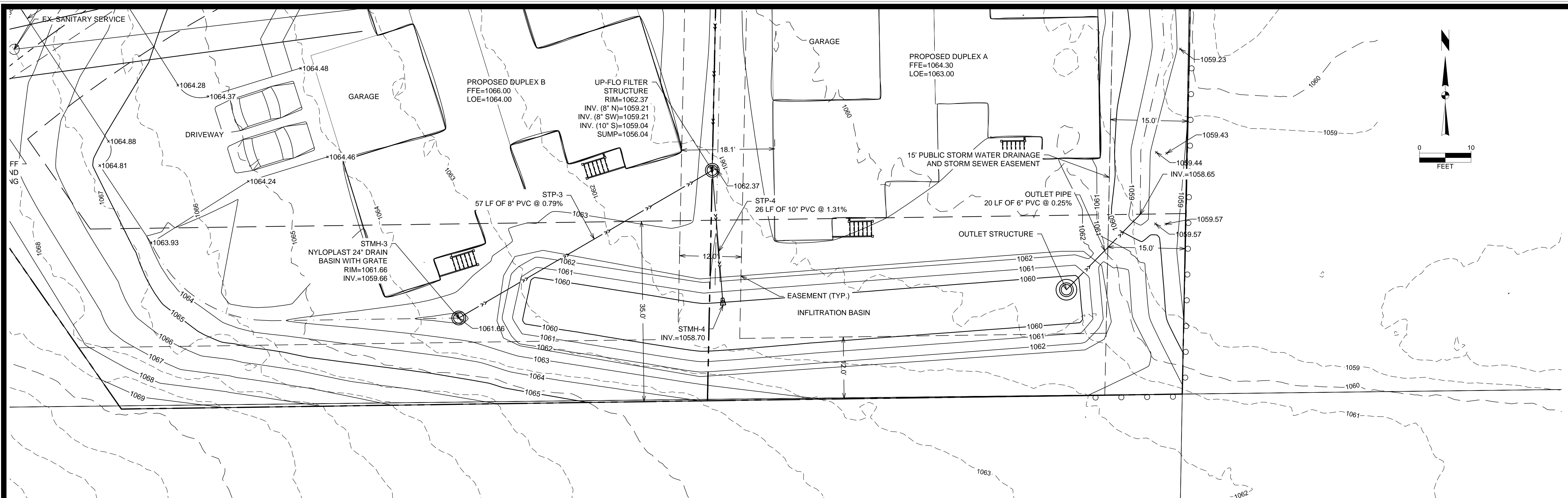

MARK	REVISION	DATE	BY
Engineer: BCA	Checked By: MLC	Date: 06-26-2019	Scale: 1" = AS SHOWN
Technician: BCA			T-R-S: TTN-RRW-SS
Project No: 119.0587.30			Sheet C 5.0

MADISON, DANE COUNTY, WI

8549 & 8557 ELDERBERRY ROAD

INFILTRATION BASIN DETAIL SHEET

SNYDER & ASSOCIATES, INC.

2727 S.W. SNYDER BLVD
ANKENY, IOWA 50023
515-964-2020 | www.snyder-associates.com

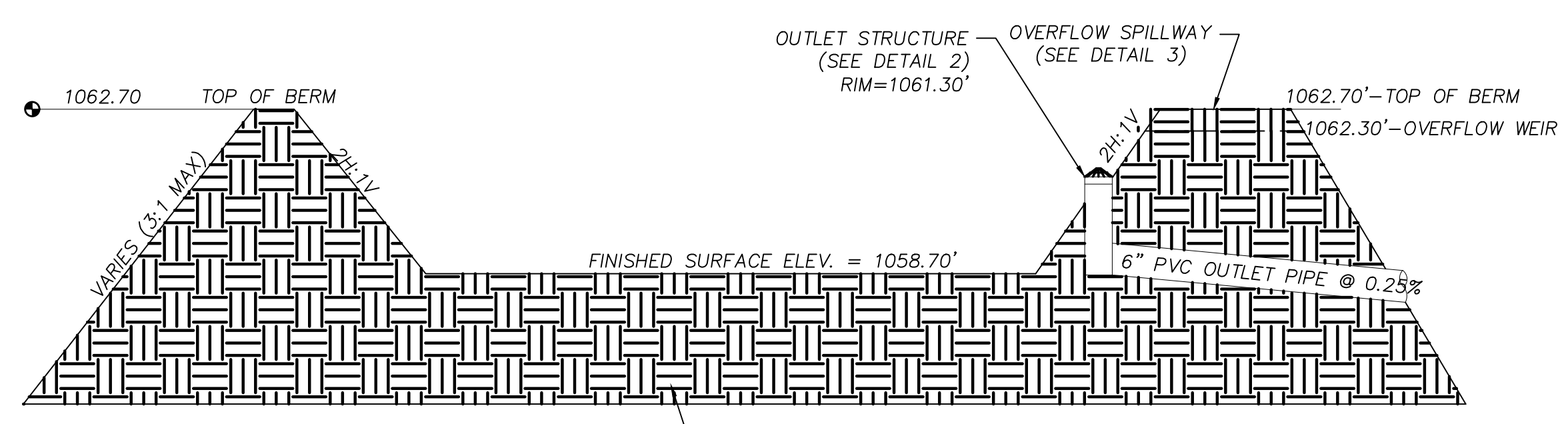

1 TYPICAL BASIN PROFILE/SECTION
SCALE: NTS

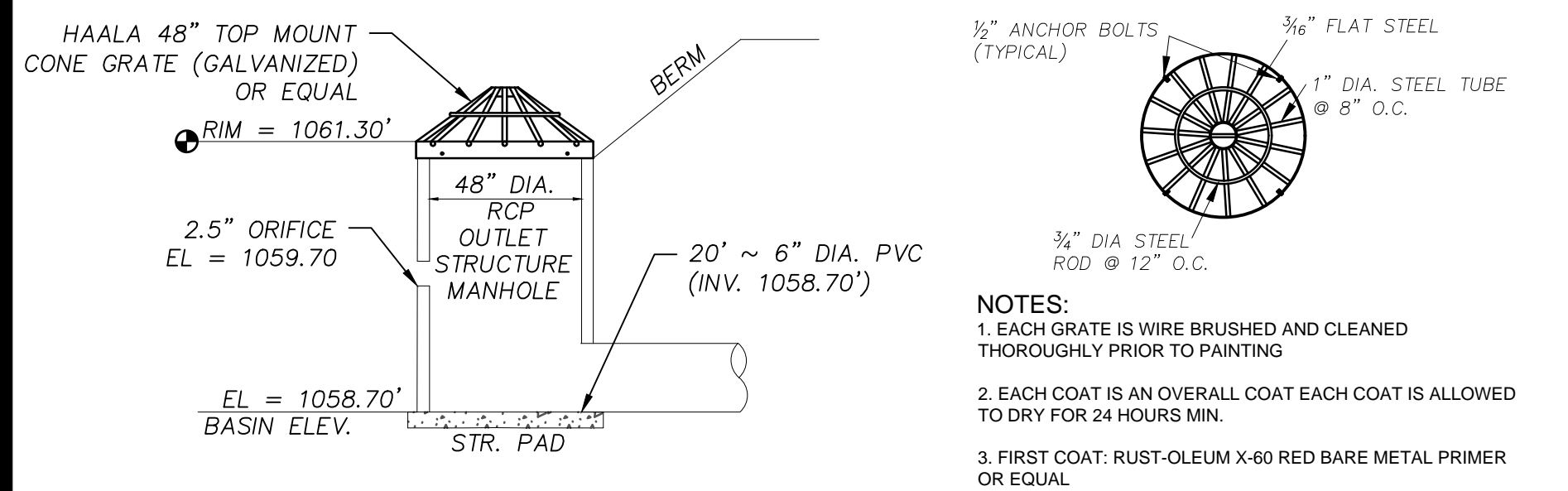

2 OUTLET STRUCTURE DETAIL
SCALE: NTS

- NOTES:
- EACH GRATE IS WIRE BRUSHED AND CLEANED THOROUGHLY PRIOR TO PAINTING
 - EACH COAT IS AN OVERALL COAT EACH COAT IS ALLOWED TO DRY FOR 24 HOURS MIN.
 - FIRST COAT: RUST-OLEUM X-60 RED BARE METAL PRIMER OR EQUAL
 - SECOND COAT: RUST-OLEUM 960 ZINC CHROMATE PRIMER OR EQUAL
 - THIRD COAT: RUST-OLEUM 1282 HIGH GLOSS AND METALLIC FINISH OR EQUAL
 - GALVANIZED AND EPOXY COATED GRATES ALSO AVAILABLE AS SPECIFIED
 - PIPE GRATES ARE ALSO AVAILABLE FOR APRON ENDWALLS

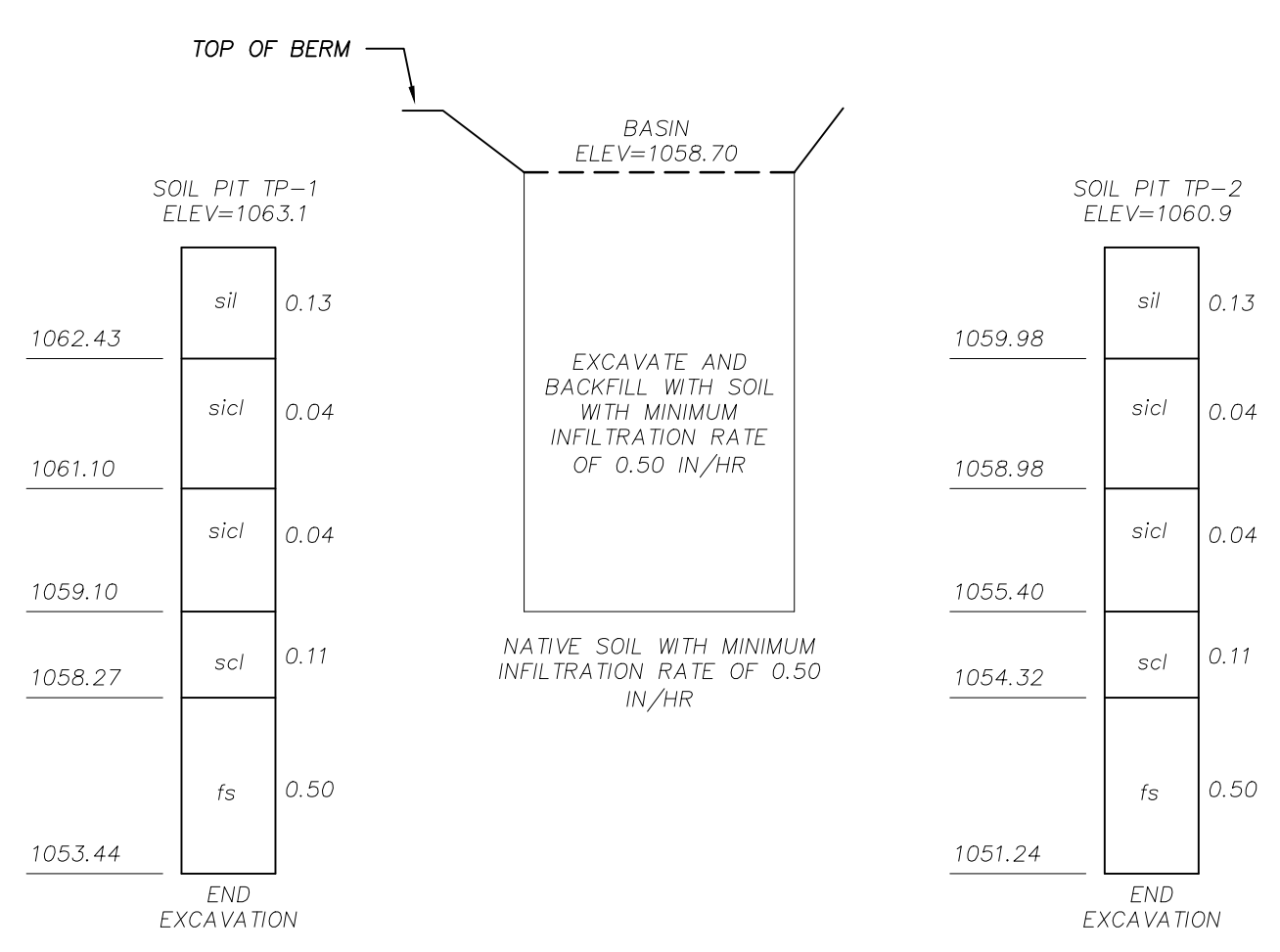

4 SOIL TEST PIT PROFILES
SCALE: NTS

CONTRACTOR SHALL FIELD VERIFY THAT INFILTRATION BASIN IS EXCAVATED ALL THE WAY TO AN EXISTING NATIVE SOIL LAYER WITH A 0.50 IN/HR. MIN. INFILTRATION RATE BASED UPON SOIL TESTING. ALL BACKFILL MATERIAL SHALL BE SAND AND HAVE A MINIMUM INFILTRATION RATE OF 0.50 IN/HR.

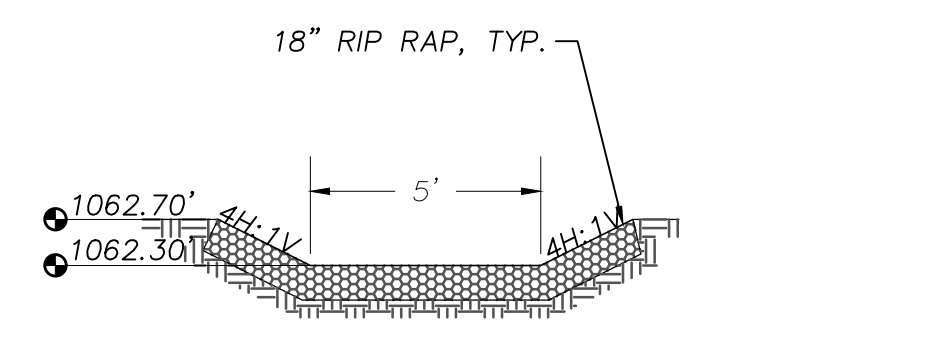

3 BROAD CRESTED OVERFLOW WEIR DETAIL (BIORETENTION BASIN)
SCALE: NTS

NOTES

- ALL ROOF DRAINS SHALL BE DIRECTED TO THE INFILTRATION BASIN EITHER THROUGH OVERLAND FLOW OR THROUGH THE STORM SEWER SYSTEM.
- IF THE ACTIVE INFILTRATION AREA IS GRADED THE EFFECTS OF COMPACTION SHALL BE MITIGATED USING THE FOLLOWING METHODS:
 - INCORPORATE SOIL ADDITIVES CONSISTING OF TWO INCHES OF COMPOST MIXED INTO TWO INCHES OF TOPSOIL.
 - THE SOIL MIX SHALL BE INCORPORATED INTO THE EXISTING SOIL USING A CHISEL PLOW OR ROTARY DEVICE WITH THE CAPABILITY OF REACHING TO 12 INCHES BELOW THE EXISTING SURFACE.
 - THE COMPOST COMPONENT SHALL MEET THE WDNR SPECIFICATION S100 COMPOST.
 - IF TURF GRASS IS UTILIZED, THE BASIN CANNOT BE USED FOR RECREATIONAL PURPOSES DUE TO COMPACTION CONCERNS.
 - TRACKED VEHICLES SHOULD BE USED DURING CONSTRUCTION TO LESSEN COMPACTION.
- SEEDING OF INFILTRATION BASIN BOTTOM AND SIDE SLOPES SHALL MEET CITY OF MADISON SPECIFICATIONS FOR INFILTRATION SEED MIX PER ARTICLE 207 - SEEDING OF THE CITY OF MADISON STANDARD SPECIFICATIONS.



EROSION CONTROL NOTES

- THE CONTRACTOR IS RESPONSIBLE FOR OBTAINING COPIES OF ALL PERMITS, INCLUDING WISDNR WPDES DISCHARGE PERMIT (IF APPLICABLE), COUNTY AND LOCAL EROSION CONTROL PERMIT. CONTRACTOR IS RESPONSIBLE FOR ABIDING BY ALL PERMIT REQUIREMENTS AND RESTRICTIONS.
- ALL EROSION CONTROL MEASURES SHALL BE INSTALLED PRIOR TO LAND DISTURBING ACTIVITIES.
- ALL INSTALLATION AND MAINTENANCE OF EROSION CONTROL PRACTICES SHALL BE IN ACCORDANCE WITH THE APPLICABLE WISCONSIN DEPARTMENT OF NATURAL RESOURCES (WDNR) TECHNICAL STANDARD, FOUND AT: http://dnr.wi.gov/topic/stormwater/standards/const_standards.html OR THE WISCONSIN CONSTRUCTION SITE BEST MANAGEMENT PRACTICE HANDBOOK IF A TECHNICAL STANDARD IS NOT AVAILABLE.
- ALL EROSION CONTROL FACILITIES SHALL BE MAINTAINED THROUGHOUT THE DURATION OF THE PROJECT AND WARRANTY PERIOD IN CONFORMANCE WITH ALL APPLICABLE PERMITS ISSUED FOR THE PROJECT.
- ALL EROSION AND SEDIMENTATION CONTROL PRACTICES SHALL BE INSPECTED WEEKLY AND WITHIN 24 HOURS AFTER EVERY PRECIPITATION EVENT THAT PRODUCES 0.5 INCHES OF RAIN OR MORE DURING A 24 HOUR PERIOD. REPAIRS SHALL BE MADE IMMEDIATELY TO EROSION CONTROL PRACTICES AS NECESSARY.
- TEMPORARY STOCKPILES SHALL BE STABILIZED IF NOT REMOVED IN 10 DAYS. PERIMETER CONTROL ON THE DOWNHILL SIDE SHALL BE IN PLACE AT ALL TIMES (SILT FENCE OR APPROVED EQUAL).
- TEMPORARY SEED MIXTURE SHALL CONFORM TO 630.2.1.5.1.4 OF THE WISDOT STANDARD SPECIFICATIONS USE WINTER WHEAT OR RYE FOR FALL PLANTINGS STARTED AFTER SEPTEMBER 1.
- DISTURBED AREAS THAT CANNOT BE STABILIZED WITH A DENSE GROWTH OF VEGETATION BY SEEDING AND MULCHING DUE TO TEMPERATURE OR TIMING OF CONSTRUCTION, SHALL BE STABILIZED BY APPLYING ANIONIC POLYACRYLAMIDE (PAM) IN ACCORDANCE WITH WDNR TECHNICAL STANDARD 1050.
- SEDIMENT SHALL BE REMOVED FROM THE SEDIMENT BASINS TO MAINTAIN A THREE FOOT DEPTH OF TREATMENT, MEASURED BELOW THE NORMAL WATER ELEVATION. SEDIMENT WILL BE REMOVED FROM THE DIVERSION DITCHES WHEN IT REACHES HALF THE HEIGHT OF THE DITCH. SEDIMENT WILL BE REMOVED FROM BEHIND THE SILT FENCE AND DITCH CHECKS WHEN IT REACHES HALF THE HEIGHT OF THE FENCE/BALE THE SILT FENCE AND DITCH CHECKS SHALL BE REPAIRED AS NECESSARY TO MAINTAIN A BARRIER.
- ALL WATER FROM CONSTRUCTION DEWATERING SHALL BE TREATED IN ACCORDANCE WITH WDNR TECHNICAL STANDARD 1061 PRIOR TO DISCHARGE TO WATERS OF THE STATE, WETLANDS, OR OFFSITE.
- THE CONTRACTOR IS RESPONSIBLE FOR INSTALLATION OF ANY ADDITIONAL EROSION CONTROL MEASURES NECESSARY TO PREVENT EROSION AND SEDIMENTATION. ALL DISTURBED AREAS ARE TO DRAIN TO APPROVED SEDIMENT CONTROL MEASURES AT ALL TIMES DURING SITE DEVELOPMENT UNTIL FINAL STABILIZATION IS ACHIEVED. DEPENDING ON HOW THE CONTRACTOR GRADES THE SITE, IT MAY BE NECESSARY TO INSTALL TEMPORARY EROSION CONTROL AND/OR SEDIMENT TRAPS IN VARIOUS LOCATIONS THROUGHOUT THE PROJECT. TEMPORARY SEDIMENT TRAPS SHALL BE DESIGNED, INSTALLED, AND MAINTAINED IN ACCORDANCE WITH WDNR TECHNICAL STANDARD 1063.
- TRACKED MATERIAL TO ADJACENT STREETS SHALL BE COLLECTED AT THE END OF EACH WORKING DAY OR AS REQUIRED BY THE LOCAL MUNICIPALITY.
- DUST CONTROL SHALL BE PROVIDED AS NECESSARY IN ACCORDANCE WITH WDNR TECHNICAL STANDARD 106B.
- FINAL STABILIZATION OF LANDSCAPED AREAS SHALL BE IN ACCORDANCE WITH THE APPROVED LANDSCAPE PLAN.
- ALL SEEDED AREAS WILL BE FERTILIZED, RESEEDED AS NECESSARY, AND MULCHED ACCORDING TO SPECIFICATIONS IN THE APPROVED LANDSCAPE PLAN TO MAINTAIN A VIGOROUS DENSE VEGETATIVE COVER.
- THE CONTRACTOR IS RESPONSIBLE FOR PROVIDING ALL EROSION CONTROL FACILITIES AND MEASURES NECESSARY TO CONTROL EROSION AND SEDIMENTATION AT THE PROJECT SITE. THESE FACILITIES AND MEASURES MAY OR MAY NOT BE SHOWN ON THE DRAWINGS AND THEIR ABSENCE ON THE DRAWINGS DOES NOT ALLEVIATE THE CONTRACTOR FROM PROVIDING THEM. ANY MEASURES AND FACILITIES SHOWN ON THE DRAWINGS ARE THE MINIMUM ACTIONS REQUIRED.
- ERODED MATERIAL THAT HAS LEFT THE CONSTRUCTION SITE SHALL BE COLLECTED AND RETURNED TO THE SITE BY THE CONTRACTOR.
- AFTER FINAL VEGETATION IS ESTABLISHED, REMOVE ALL EROSION CONTROL FACILITIES. RESTORE AREAS DISTURBED BY THE REMOVALS.
- KEEP A COPY OF THE CURRENT EROSION CONTROL PLAN ON SITE THROUGHOUT THE DURATION OF THE PROJECT.
- COMPLETE AND STABILIZE SEDIMENT BASINS/TRAPS PRIOR TO MASS LAND DISTURBANCE TO CONTROL RUNOFF DURING CONSTRUCTION. REMOVE SEDIMENT AS NEEDED TO MAINTAIN 3 FEET OF DEPTH TO THE OUTLET, AND PROPERLY DISPOSE OF SEDIMENT REMOVED DURING MAINTENANCE. CONSTRUCT AND MAINTAIN THE SEDIMENT BASIN PER WDNR TECHNICAL STANDARDS.
- PROPERLY DISPOSE OF ALL WASTE AND UNUSED BUILDING MATERIALS (INCLUDING GARBAGE, DEBRIS, CLEANING WASTES, OR OTHER CONSTRUCTION MATERIALS) AND DO NOT ALLOW THESE MATERIALS TO BE CARRIED BY RUNOFF INTO THE RECEIVING CHANNEL.
- FOR NON-CHANNELIZED FLOW ON DISTURBED OR CONSTRUCTED SLOPES 4:1, PROVIDE CLASS I TYPE A EROSION CONTROL MATTING. SELECT EROSION MATTING FROM APPROPRIATE MATRIX IN WDOT'S FACILITIES DEVELOPMENT MANUAL AND INSTALL AND MAINTAIN PER WDNR TECHNICAL STANDARDS.
- FOR CHANNELIZED FLOW ON DISTURBED OR CONSTRUCTED AREAS, PROVIDE CLASS I TYPE B EROSION CONTROL MATTING. SELECT EROSION MATTING FROM APPROPRIATE MATRIX IN WDOT'S FACILITIES DEVELOPMENT MANUAL. INSTALL AND MAINTAIN PER WDNR TECHNICAL STANDARDS.
- MAKE PROVISIONS FOR WATERING DURING THE FIRST 8 WEEKS FOLLOWING SEEDING OR PLANTING OF DISTURBED AREAS WHENEVER MORE THAN 7 CONSECUTIVE DAYS OF DRY WEATHER OCCUR.

CONSTRUCTION SEQUENCE

- INSTALL AND MAINTAIN THE TEMPORARY GRAVEL CONSTRUCTION ENTRANCE/EXIT'S AS DESCRIBED IN THE DANE COUNTY EROSION CONTROL AND STORMWATER MANAGEMENT MANUAL. ADDITIONALLY INSTALL CONSTRUCTION EQUIPMENT PARKING AREAS. STABILIZE BARE AREAS IMMEDIATELY WITH GRAVEL AND TEMPORARY VEGETATION AS CONSTRUCTION TAKES PLACE. THE TEMPORARY ACCESS POINT SHALL BE PLACED IN THE LOCATION SHOWN ON THE GRADING AND EROSION CONTROL PLAN. THE ENTRANCE/EXITS WILL BE INSPECTED DAILY. IF THE AGGREGATE WITHIN THE TEMPORARY ACCESS PADS BECOMES COVERED WITH SOIL OR IF SIGNIFICANT QUANTITIES OF SOIL ARE TRACKED ONTO SURROUNDING ROADS THEN ADDITIONAL AGGREGATE WILL BE INSTALLED TO ALLOW THE ENTRANCE/EXITS TO FUNCTION PROPERLY.
- INSTALL EROSION AND SEDIMENT CONTROL BARRIERS (SILT FENCE) IMMEDIATELY DOWNSLOPE OF AREAS TO BE DISTURBED DURING CONSTRUCTION AS SHOWN ON THE APPROVED GRADING PLAN. THE BARRIERS MUST BE INSTALLED PARALLEL TO THE SITE CONTOURS TO THE EXTENT PRACTICABLE WITH THE ENDS EXTENDED UPSLOPE ONE TO TWO FEET TO PREVENT FLANKING OF THE RUNOFF. AT NO TIME FROM THE START OF ROUGH GRADING UNTIL SITE STABILIZATION SHALL AN UNBROKEN SLOPE EXIST BETWEEN DISTURBED AREAS AND THE RECEIVING WATERS. THE DANE COUNTY EROSION CONTROL AND STORMWATER MANAGEMENT MANUAL WILL BE REFERENCED FOR THE PROPER INSTALLATION AND MAINTENANCE OF SILT FENCE AND ALL OTHER EROSION CONTROL MEASURES ON THE SITE.
- STRIP TOPSOIL FROM THE AREAS OF THE SITE THAT WILL BE GRADED WITHIN 48 HOURS. ANY AREAS THAT WILL NOT BE IMMEDIATELY GRADED MUST NOT BE STRIPPED OF TOPSOIL UNTIL THE PRECEDING AREAS ARE TOPSOILED, SEEDED AND MULCHED. PLACE SOIL STOCKPILES AT LEAST 25 FEET AWAY FROM ANY DOWNSLOPE STREET, DRIVEWAY, OR DITCH. ALL TOPSOIL PILES WILL HAVE SILT FENCE PLACED ON THEIR DOWNSLOPE SIDES. TOPSOIL PILES WILL BE SEEDED WITH ANNUAL RYE IF THEY ARE IN PLACE FOR MORE THAN 7 DAYS. ANY AREAS LEFT INACTIVE FOR MORE THAN 7 DAYS WILL BE STABILIZED IMMEDIATELY WITH SEED AND MULCH.
- GRADING WILL BE PHASED TO THE EXTENT PRACTICABLE TO LIMIT THE AMOUNT OF THE EXPOSED SOIL AT ANY ONE TIME AND TO PROVIDE A BUFFER BETWEEN THE GRADED AREAS AND THE RECEIVING WATERS. THE INTENT OF THESE GRADING RESTRICTIONS IS TO PROVIDE AN UNDISTURBED BUFFER AREA ALLOWING ADDITIONAL EROSION AND SEDIMENTATION PROTECTION DURING CONSTRUCTION.
- TOPSOIL, SEED AND MULCH ALL AREAS WHICH ARE AT FINAL GRADE AND WHICH WILL NOT BE DISTURBED DURING SUBSEQUENT PHASES OF CONSTRUCTION. ANY AREAS LEFT INACTIVE FOR MORE THAN 7 DAYS MUST BE STABILIZED IMMEDIATELY. CLASS 1 URBAN, TYPE A EROSION MATTING OR HYDRO-MULCH TO BE USED IN TERRACE AND 5' BEHIND SIDEWALK PER SPSS 205.4.2.
- INSTALL SANITARY SEWER, STORM SEWER AND WATER MAINS.
- COMPLETE FINAL GRADING FOR ROADWAYS AND STABILIZE WITH GRAVEL.
- COMPLETE FINAL GRADE OF THE LOTS.
- UTILITY TRENCHES SHALL BE FILLED WITH SUITABLE BACKFILL MATERIAL AND COMPACTED AS NEEDED. TOPSOIL SHALL BE REPLACED, FERTILIZED, SEEDED AND PROTECTED AS CALLED FOR BELOW IN ITEMS 11 AND 12. UTILITY CONSTRUCTION SHALL BE COORDINATED WITH OTHER GRADING ACTIVITIES SO THAT RESTORATION CAN BE COMPLETED AS SOON AS POSSIBLE AFTER CONSTRUCTION.
- WITHIN 7 DAYS OF THE COMPLETION OF FINAL GRADING, A MINIMUM OF 4 INCHES OF TOPSOIL SHALL BE REPLACED ON ALL DISTURBED SURFACES THAT ARE TO BE REVEGETATED. TOPSOIL SHALL BE UNIFORMLY PLACED, GRADED SMOOTH AND SCARIFIED FOR SEEDING.
- FERTILIZE ALL AREAS TO BE SEEDED OR SODDED WITH 500LBS. PER ACRE OF 16-8-8 (MINIMUM). INCORPORATE THE FERTILIZER INTO THE SOIL BY SCARIFYING AS INDICATED ABOVE IN ITEM 11. SEED ALL DISTURBED AREAS WITH THE FOLLOWING SEEDING MIXTURE:
 30.50 LBS/ACRE OF KENTUCKY BLUEGRASS
 17.50 LBS/ACRE OF RED FESCUE
 17.50 LBS/ACRE OF HARD FESCUE
 22.00 LBS/ACRE OF PERENNIAL RYE GRASS

THE OWNER RESERVES THE RIGHT TO REVISE THE SEEDING MIXTURE SUBJECT TO APPROVAL BY THE CITY OF SUN PRAIRIE.

SOD MAY BE SUBSTITUTED FOR SEEDING ON ALL AREAS TO BE SEEDED AND IS RECOMMENDED FOR ALL AREAS WITH SLOPES OF 5:1 OR STEEPER.

MULCH ALL SEEDED AREAS WITH 1.5 TONS PER ACRE OF CLEAN STRAW. STRAW SHALL BE ANCHORED IN PLACE WITH SUITABLE EQUIPMENT OR STAKING WITH TWINE.

FOR AREAS ON WHICH GRADING IS COMPLETED AFTER OCTOBER 15, TEMPORARY SEED (SUCH AS RYE OR SINTER WHEAT) AND MULCH MUST BE APPLIED AS SOON AS THESE AREAS REACH THEIR FINAL GRADE. ADDITIONAL EROSION CONTROL BARRIERS MAY BE NEEDED DOWNSLOPE OF THESE AREAS UNTIL FINAL SEEDING OR SODDING IS COMPLETED IN SPRING (BY JUNE 1). ANY AREAS WITH SLOPES GREATER THAN 6:1 MUST BE SEEDED AND MULCHED BUT NOT TOPSOILED. AREAS WITH SLOPED LESS THAN 6:1 MUST BE TOPSOILED, SEEDED AND MULCHED. ALL AREAS MUST BE TOPSOILED, SEEDED AND MULCHED AS DESCRIBED ABOVE IN THE FOLLOWING SPRING.

WHENEVER POSSIBLE, PRESERVE EXISTING TREES, SHRUBS, AND OTHER VEGETATION. TO PREVENT ROOT DAMAGE, DO NOT GRADE, PLACE SOIL PILES, OR PARK VEHICLES NEAR TREES MARKED FOR PRESERVATION.

SILT FENCE MAINTENANCE: EROSION CONTROL BARRIERS (SILT FENCE) MUST BE INSPECTED WITHIN 24 HOURS AFTER EACH RAINFALL OF 0.5-INCHES OR MORE, AND DAILY DURING PERIODS OF PROLONGED RAINFALL. REPAIRS OR REPLACEMENT SHALL BE MADE IMMEDIATELY. SEDIMENT DEPOSITS ON THE UPSLOPE SIDE ON THE SILT FENCES SHALL BE REMOVED WHEN THE DEPOSITS REACH HALF THE HEIGHT OF THE SILT FENCE.

GRAVEL TRACKING PAD MAINTENANCE: ADDITIONAL STONE IS REQUIRED IF EXISTING STONE BECOMES BURIED OR IF SEDIMENT IS NOT BEING REMOVED EFFECTIVELY FROM TIRES. SEDIMENT THAT IS TRACKED ONTO THE ROADWAY MUST BE REMOVED IMMEDIATELY. TRACKING PADS MAY REQUIRE PERIODIC CLEANING TO MAINTAIN THE EFFECTIVENESS OF THE PRACTICE, WHICH MAY INCLUDE THE REMOVAL AND RE-INSTALLATION OF THE STONE.

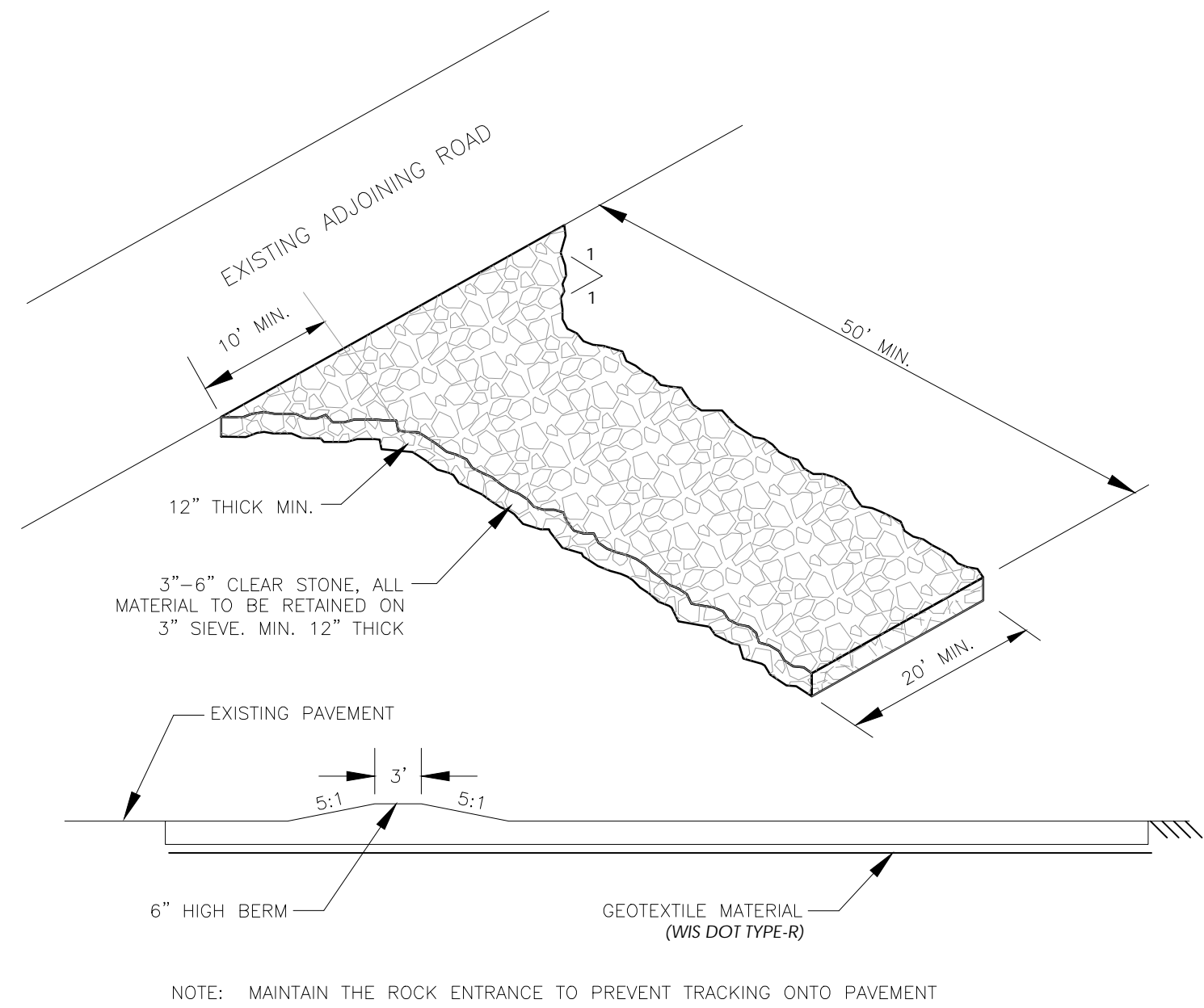

1 CONSTRUCTION ENTRANCE DETAIL
SCALE: NTS

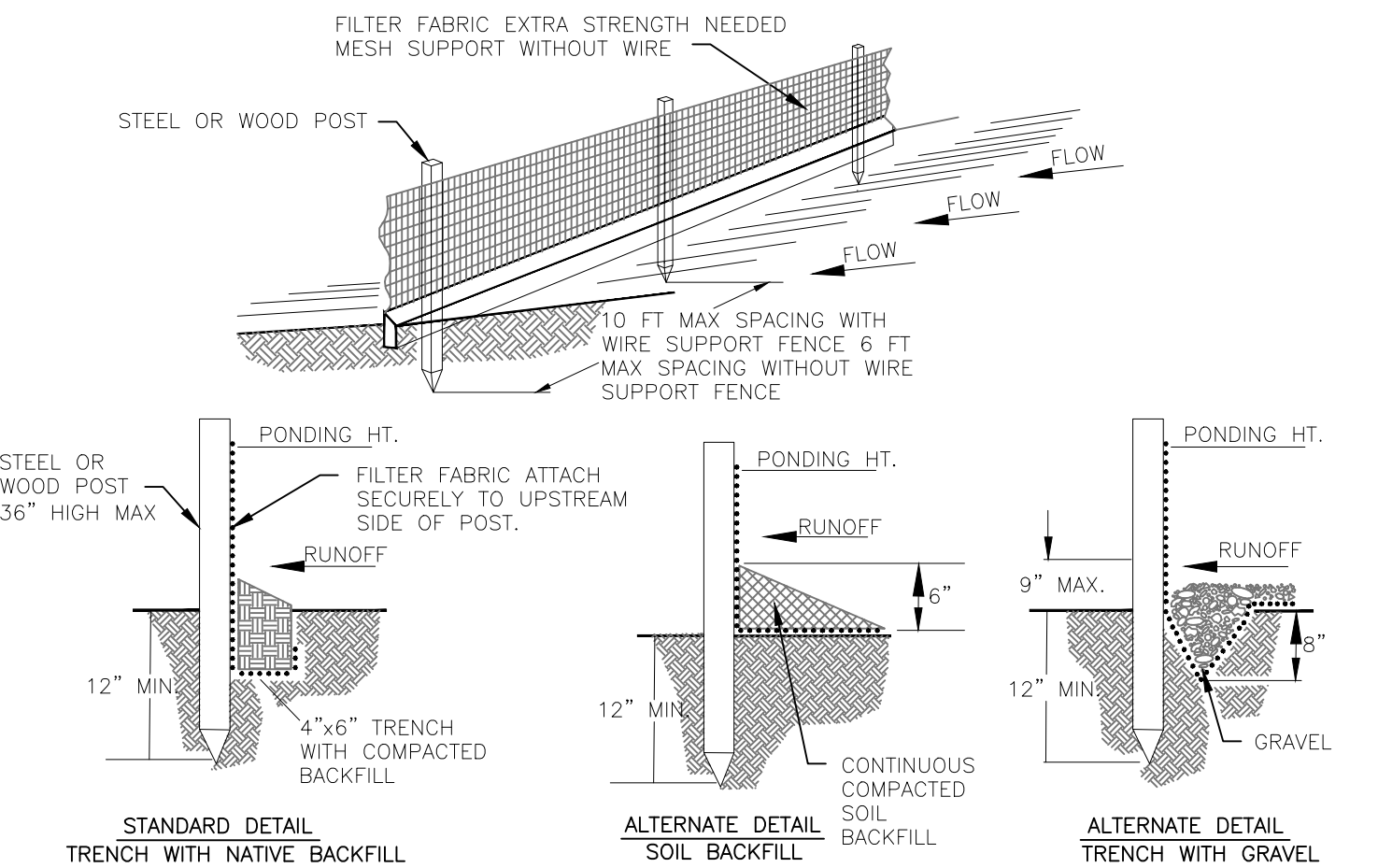

- NOTE:**
- INSPECT FENCE WEEKLY AND AFTER EACH RAIN EVENT OF 0.5 INCHES AND REPAIR IF REQUIRED. REMOVE SEDIMENT WHEN NECESSARY OR WHEN SEDIMENT REACHES 1/2 OF FENCE HEIGHT.
 - REMOVED SEDIMENT SHALL BE DEPOSITED TO AN AREA THAT WILL NOT CONTRIBUTE SEDIMENT OFF-SITE AND CAN BE PERMANENTLY STABILIZED.
 - SILT FENCE SHALL BE PLACED ON SLOPE CONTOURS TO MAXIMIZE PONDING EFFICIENCY.
 - SILT FENCE SHALL BE INSTALLED AND MAINTAINED IN ACCORDANCE WITH WDNR TECHNICAL STANDARD 1056.

2 SILT FENCE DETAIL
SCALE: NTS

MARK	REVISION	DATE	BY
Engineer: BCA	Checked By: MLC	Date: 06-28-2019	Scale: 1" = AS SHOWN
Technician: BCA			T-R-S: TTN-RRW-SS
Project No: 119.0587.30			Sheet C 6.0

MADISON, DANE COUNTY, WI

2727 S.W. SNYDER BLVD
 ANKENY, IOWA 50023
 515-984-2020 | www.snyder-associates.com

8549 & 8557 ELDERBERRY ROAD

EROSION CONTROL NOTES & DETAILS

SNYDER & ASSOCIATES, INC.



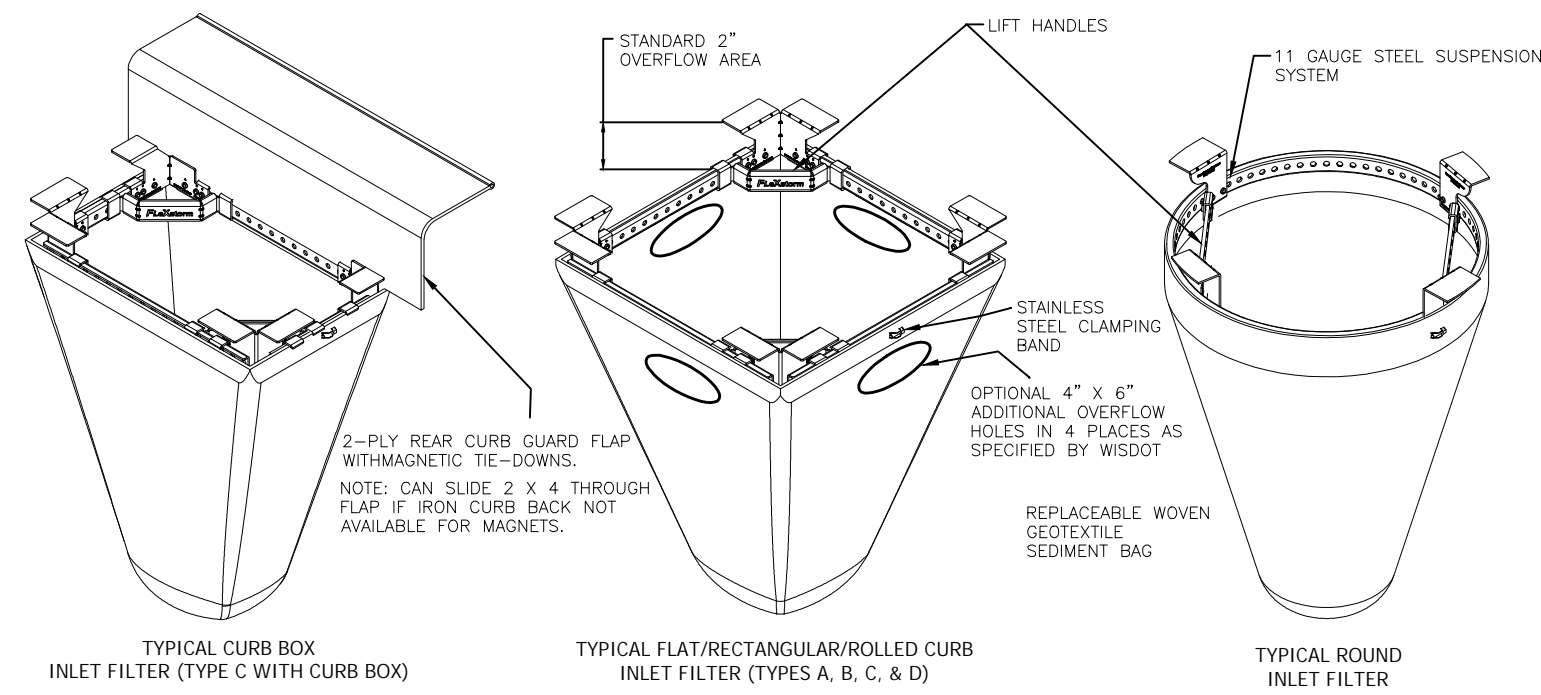

MATERIALS:
 1. FRAMING - 11 GAUGE STEEL CORROSION RESISTANT
 2. SEDIMENT BAG - WOVEN GEOTEXTILE (TYPE FF OR APPROVED ALTERNATE). 2 CUBIC FT TYP. VOLUME.
 3. STAINLESS STEEL LOCKING BAND SECURING BAG TO FRAME

INSTALLATION:
 1. REMOVE GRATE
 2. DROP FLEXFORM INLET FILTER ONTO LOAD BEARING LIP OF CASTING OR CONCRETE STRUCTURE
 3. REPLACE GRATE

DESIGNED BY:	ALL PRODUCTS MANUFACTURED BY INLET & PIPE PROTECTION, INC. 24137 W. 111th ST. WAPORVILLE, IA. WWW.INLETFILTERS.COM (566) 287-8855 PH (630) 355-3477 FX INFO@INLETFILTERS.COM
DATE:	10/15/2019
PROJECT:	WISDOT INLET FILTERS
SHEET:	1 OF 1

1 CATCH-ALL INLET PROTECTION DETAIL
 SCALE: NTS

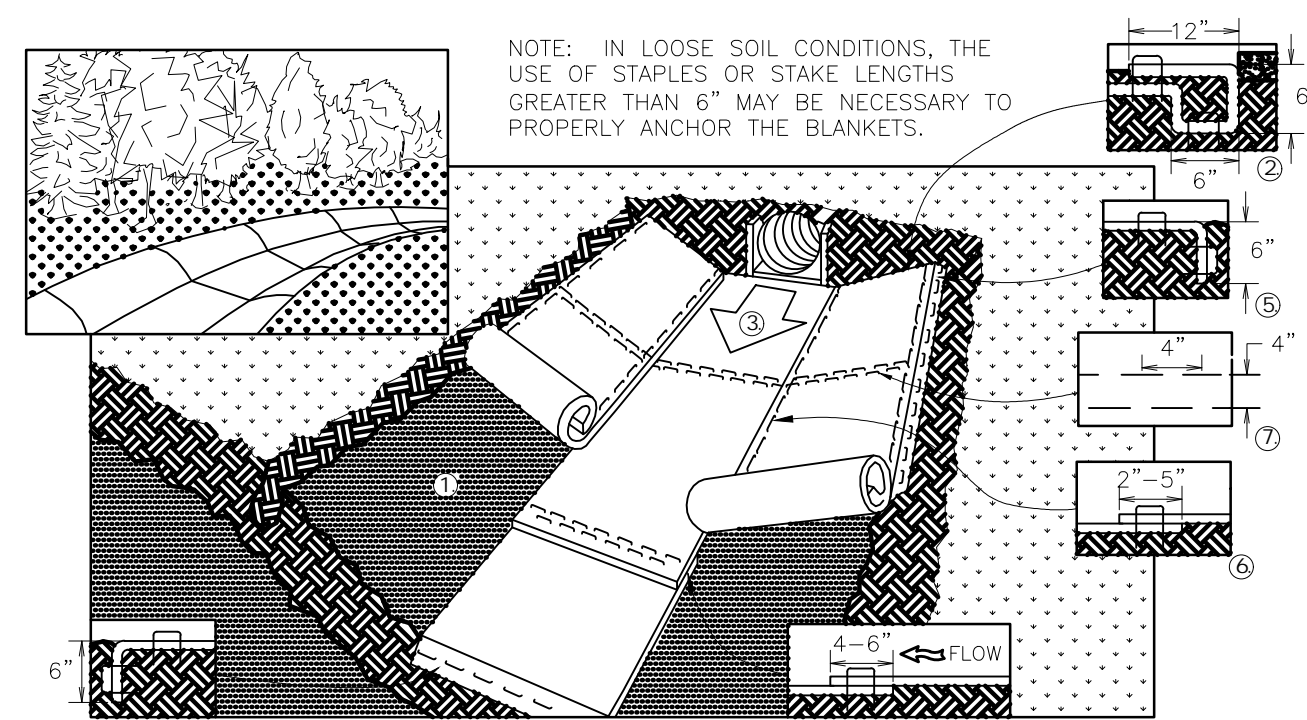

- PREPARE SOIL BEFORE INSTALLING BLANKETS, INCLUDING APPLICATION OF FERTILIZER AND SEED.
- BEGIN AT THE TOP OF THE CHANNEL BY ANCHORING THE BLANKET IN A 6" DEEP X 6" WIDE TRENCH WITH APPROXIMATELY 12" OF BLANKET EXTENDED BEYOND THE UP-SLOPE PORTION OF THE TRENCH. ANCHOR THE BLANKET WITH A ROW OF STAPLES/STAKES APPROXIMATELY 12" APART IN THE BOTTOM OF THE TRENCH. BACKFILL AND COMPACT THE TRENCH AFTER STAPLING. APPLY SEED TO COMPACTED SOIL AND FOLD REMAINING 12" PORTION OF BLANKET BACK OVER SEED AND COMPACTED SOIL. SECURE BLANKET OVER COMPACTED SOIL WITH A ROW OF STAPLES/STAKES SPACED APPROXIMATELY 12" APART ACROSS THE WIDTH OF THE BLANKET.
- ROLL CENTER BLANKET IN DIRECTION OF WATER FLOW IN BOTTOM OF CHANNEL. BLANKETS WILL UNROLL WITH APPROPRIATE SIDE AGAINST THE SOIL SURFACE. ALL BLANKETS MUST BE SECURELY FASTENED TO THE SOIL SURFACE BY PLACING STAPLES/STAKES IN APPROPRIATE LOCATIONS AS RECOMMENDED BY THE MANUFACTURER.
- PLACE CONSECUTIVE BLANKETS END OVER END (SHINGLE STYLE) WITH A 4-6" OVERLAP. USE A DOUBLE ROW OF STAPLES STAGGERED 4" APART AND 4" ON CENTER TO SECURE BLANKETS.
- FULL LENGTH EDGE OF BLANKETS AT TOP OF SIDE SLOPE MUST BE ANCHORED WITH A ROW OF STAPLES/STAKES APPROXIMATELY 12" APART IN A 6" DEEP X 6" WIDE TRENCH. BACKFILL AND COMPACT THE TRENCH AFTER STAPLING.
- A STAPLE CHECK SLOT IS RECOMMENDED AT 30 TO 40 FOOT INTERVALS. USE A DOUBLE ROW OF STAPLES STAGGERED 4" APART AND 4" ON CENTER OVER ENTIRE WIDTH OF THE CHANNEL.
- THE TERMINAL END OF THE BLANKETS MUST BE ANCHORED WITH A ROW OF STAPLES/STAKES APPROXIMATELY 12" APART IN A 6" DEEP X 6" WIDE TRENCH. BACKFILL AND COMPACT THE TRENCH AFTER STAPLING.
- EROSION MAT SHALL EXTEND FOR WHICHEVER IS GREATER: UPSLOPE ONE FOOT MIN. VERTICALLY FROM DITCH BOTTOM OR 6" HIGHER THAN DESIGN FLOW DEPTH.
- EROSION MAT SHALL BE INSTALLED AND MAINTAINED IN ACCORDANCE WITH WDNR TECHNICAL STANDARDS 1053.

3 EROSION CONTROL MAT - CHANNEL INSTALLATION
 SCALE: NTS

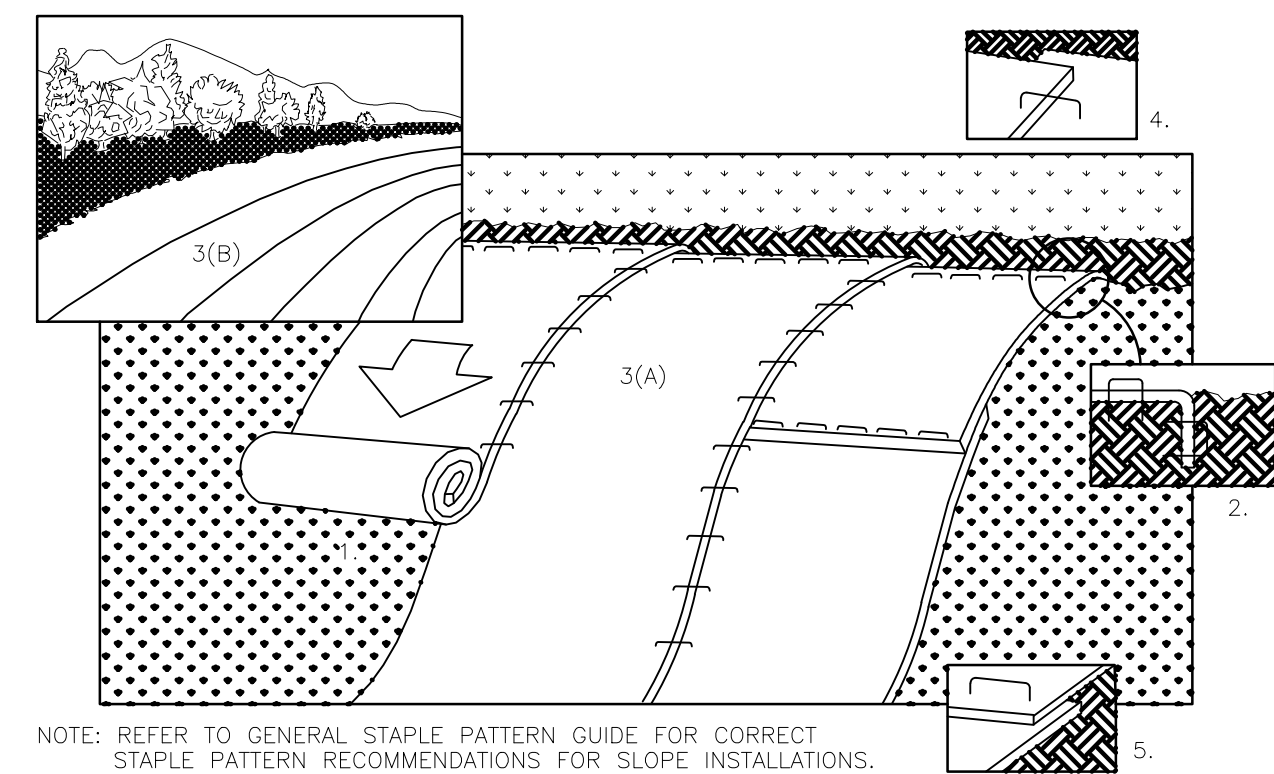

- NOTE: REFER TO GENERAL STAPLE PATTERN GUIDE FOR CORRECT STAPLE PATTERN RECOMMENDATIONS FOR SLOPE INSTALLATIONS.
- PREPARE SOIL BEFORE INSTALLING BLANKETS, INCLUDING APPLICATION OF FERTILIZER AND SEED. NOTE: WHEN USING CELL-O-SEED DO NOT SEED PREPARED AREA. CELL-O-SEED MUST BE INSTALLED WITH PAPER SIDE DOWN.
 - BEGIN AT THE TOP OF THE SLOPE BY ANCHORING THE BLANKET IN 6" DEEP X 6" WIDE TRENCH. BACKFILL AND COMPACT THE TRENCH AFTER STAPLING.
 - ROLL THE BLANKETS (A.) DOWN OR (B.) HORIZONTALLY ACROSS THE SLOPE.
 - THE EDGES OF PARALLEL BLANKETS MUST BE STAPLED WITH APPROXIMATELY 2" OVERLAP.
 - WHEN BLANKETS MUST BE SPLICED DOWN THE SLOPE, PLACE BLANKETS END OVER END (SHINGLE STYLE) WITH APPROXIMATELY 4" OVERLAP. STAPLE THROUGH OVERLAPPED AREA, APPROXIMATELY 12" APART.
 - ALL BLANKETS MUST BE SECURELY FASTENED TO THE SLOPE BY PLACING STAPLES/STAKES IN APPROPRIATE LOCATIONS AS RECOMMENDED BY THE MANUFACTURER.
 - EROSION MAT SHALL BE INSTALLED AND MAINTAINED IN ACCORDANCE WITH WDNR TECHNICAL STANDARD # 1052.

2 EROSION CONTROL MAT - SLOPE INSTALLATION
 SCALE: NTS

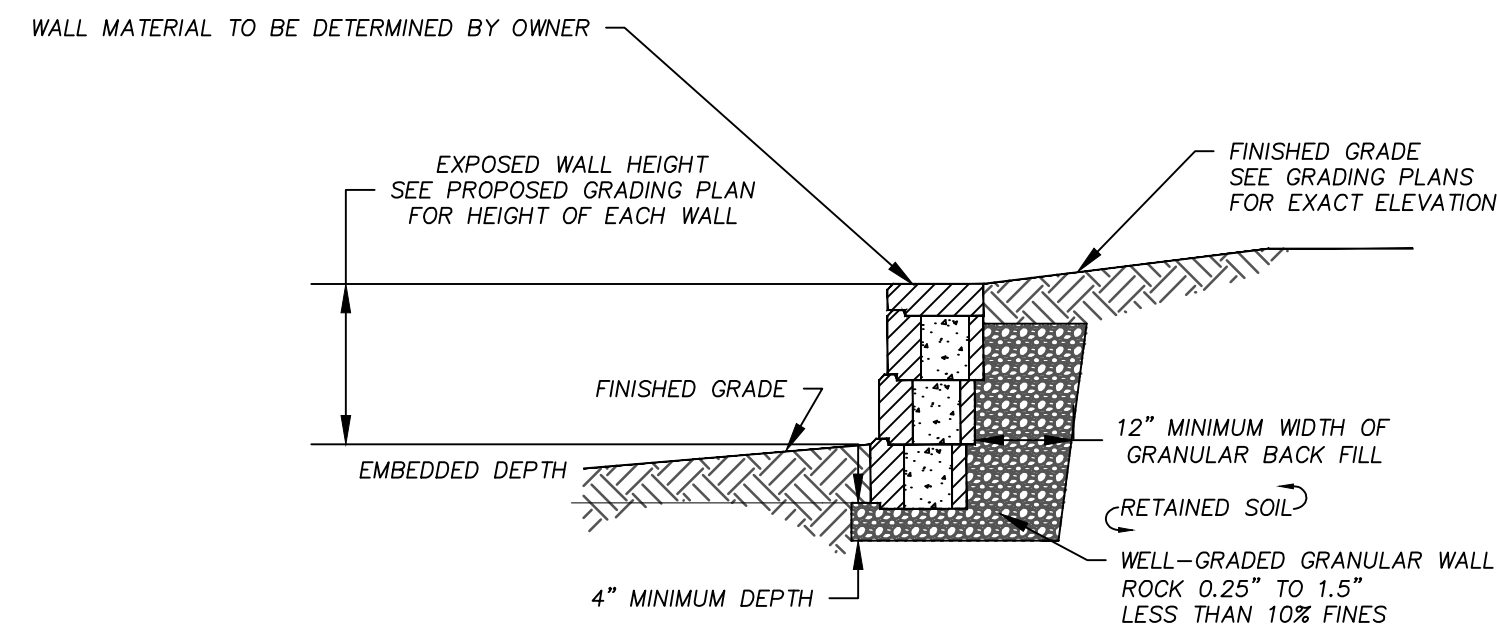

4 RETAINING WALL DETAIL
 SCALE: NTS

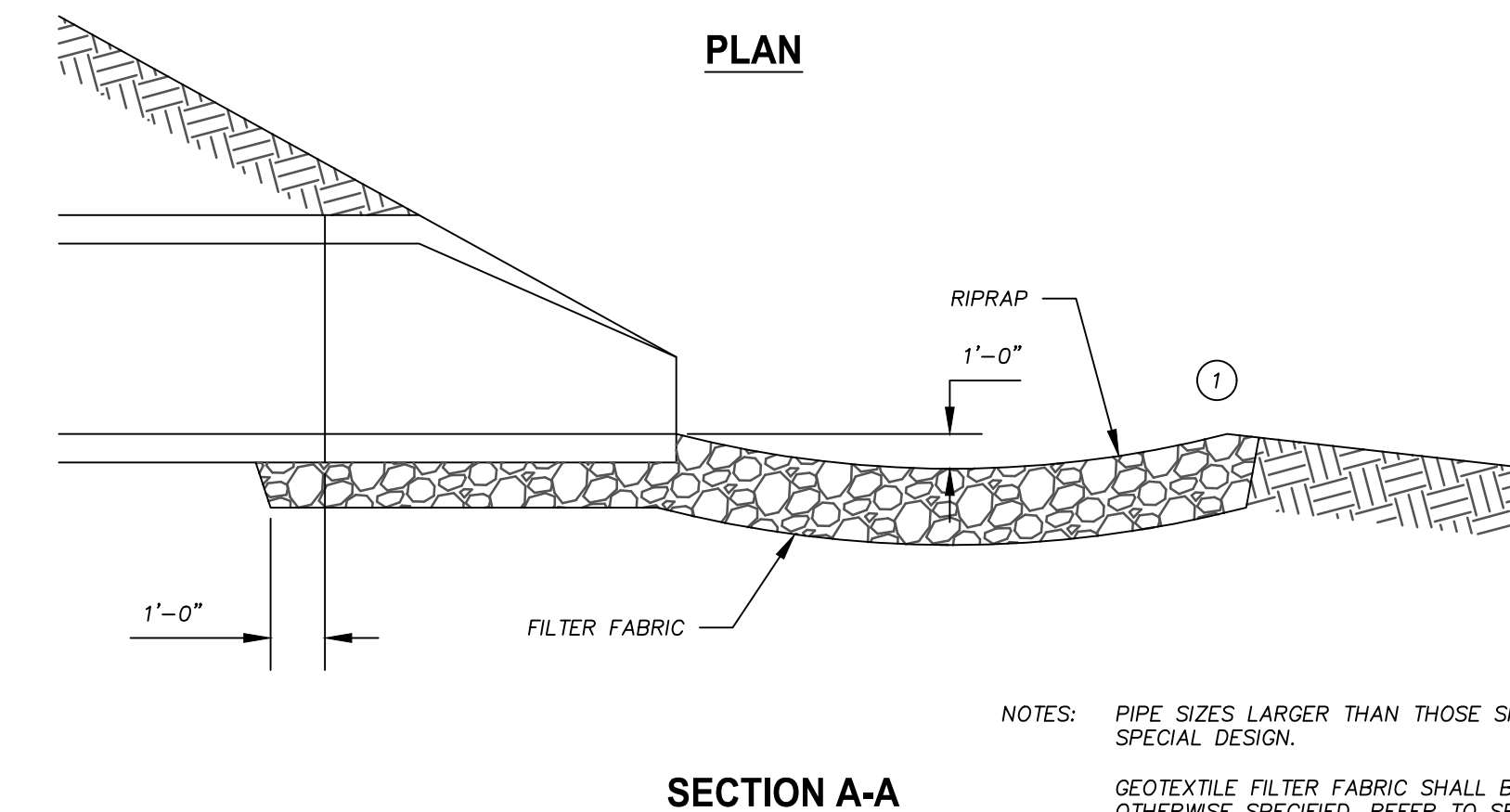
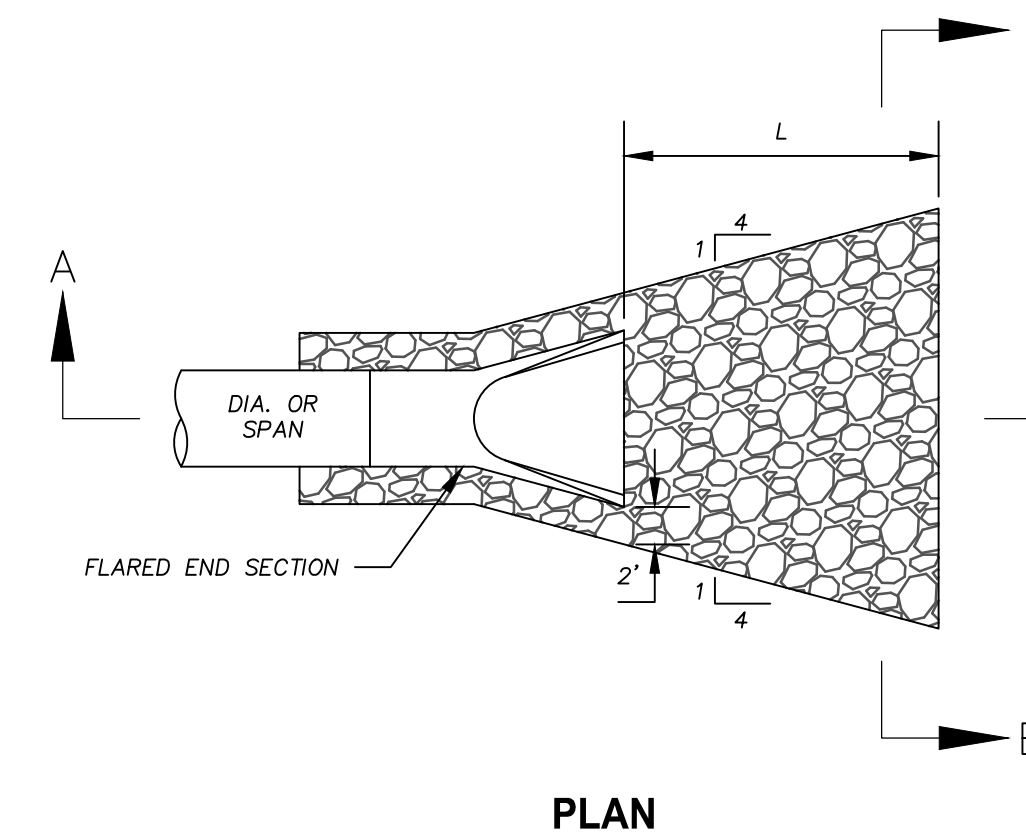
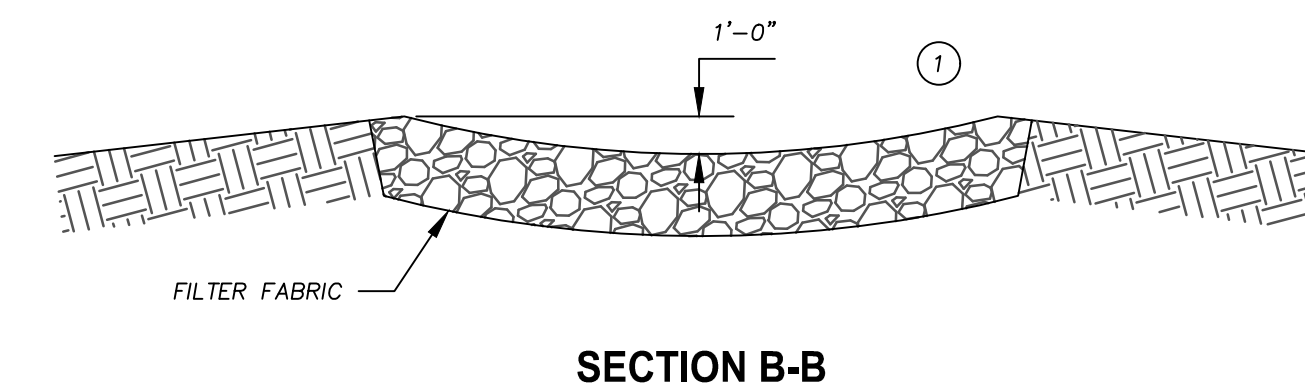

NOTES: PIPE SIZES LARGER THAN THOSE SHOWN REQUIRE A SPECIAL DESIGN.
 GEOTEXTILE FILTER FABRIC SHALL BE TYPE "HR" UNLESS OTHERWISE SPECIFIED. REFER TO SECTION 401.4.1.
 ① FOR PIPES GREATER THAN OR EQUAL TO 30" USE 1.5'.

TABLE OF QUANTITIES
 RIPRAP AT RCP OUTLETS

DIA. OF ROUND PIPE (IN.)	L (FT.)	CLASS II	CLASS III	CLASS IV
		d50=6"	d50=9"	d50=12"
12	8	2.8	4.1	5.5
15	8	2.9	4.4	5.8
18	10	3.9	5.9	7.8
21	10	4.2	6.3	8.4
24	12	5.5	8.3	11.0
27	12	5.8	8.7	11.6
30	14	7.3	10.9	14.5
36	16	9.2	13.8	18.3
42	18	10.9	16.3	21.7
48	20	12.9	19.4	25.8

TABLE OF QUANTITIES
 RIPRAP AT RCP-A OUTLETS OR BOXES OF EQUIVALENT SPAN WIDTH

SPAN OF PIPE ARCH (IN.)	L (FT.)	CLASS II	CLASS III	CLASS IV
		d50=6"	d50=9"	d50=12"
22	10	3.9	5.9	7.8
28	12	5.5	8.2	10.9
36	14	7.2	10.8	14.3
43	16	9.2	13.7	18.3
51	18	10.9	16.3	21.7
58	20	12.7	19.0	25.4

5 RIP-RAP & FABRIC DETAIL FOR ENDWALLS
 SCALE: NTS

MARK	REVISION	DATE	BY
Engineer: BCA	Checked By: MLC	Date: 06-26-2019	Scale: 1" = AS SHOWN
Technician: BCA			T-RS: TTN-RRW-SS
			Project No: 119.0587.30
			Sheet C 7.0

MADISON, DANE COUNTY, WI
 2727 S.W. SNYDER BLVD
 ANKENY, IOWA 50023
 515-964-2020 | www.snyder-associates.com

8549 & 8557 ELDERBERRY ROAD
 EROSION CONTROL DETAILS
SNYDER & ASSOCIATES, INC.



GENERAL CONDITIONS

- THE CONTRACTOR SHALL NOTIFY THE OWNER AND THE MUNICIPALITY TWO WORKING DAYS (48 HOURS) PRIOR TO THE START OF CONSTRUCTION.
 - THE CONTRACTOR SHALL INDEMNIFY THE OWNER, THE ENGINEER, AND THE MUNICIPALITY, THEIR AGENTS, ETC. FROM ALL LIABILITY INVOLVED WITH THE CONSTRUCTION, INSTALLATION, AND TESTING OF THE WORK ON THIS PROJECT.
 - SITE SAFETY SHALL BE THE SOLE RESPONSIBILITY OF THE CONTRACTOR.
 - THE BIDDER WILL BE SOLELY RESPONSIBLE FOR DETERMINING QUANTITIES AND SHALL STATE SUCH QUANTITIES IN HIS PROPOSAL. HE SHALL BASE HIS BID ON HIS OWN ESTIMATE OF THE WORK REQUIRED AND SHALL NOT RELY ON THE ENGINEER'S ESTIMATE.
 - THE CONTRACTOR IS RESPONSIBLE FOR EXAMINING ALL SITE CONDITIONS PRIOR TO COMMENCEMENT OF CONSTRUCTION AND SHALL COMPARE FIELD CONDITIONS WITH DRAWINGS.
 - THE CONTRACTOR IS RESPONSIBLE FOR FIELD VERIFYING ALL UTILITY INFORMATION SHOWN ON THE PLANS PRIOR TO THE START OF CONSTRUCTION. THE CONTRACTOR SHALL CALL DIGGER'S HOTLINE AT 1-800-242-8511 TO NOTIFY THE UTILITIES OF HIS INTENTIONS, AND TO REQUEST FIELD STAKING OF EXISTING UTILITIES.
 - CONTRACTOR IS ADVISED THAT ALL MUD AND DEBRIS MUST NOT BE DEPOSITED ONTO THE ADJACENT ROADWAYS PER THE REQUIREMENT OF THE MUNICIPALITY OR OTHER APPROPRIATE GOVERNMENT AGENCIES.
 - ANY ADJACENT PROPERTIES OR ROAD RIGHT-OF-WAYS WHICH ARE DAMAGED DURING CONSTRUCTION MUST BE RESTORED BY THE CONTRACTOR. THE COST OF THE RESTORATION IS CONSIDERED INCIDENTAL, AND SHOULD BE INCLUDED IN THE BID PRICES.
 - ALL STATION AND OFFSET DISTANCES FOR UTILITY STRUCTURES ARE TO THE CENTER OF STRUCTURES EXCEPT FOR STORM SEWER CURB INLETS, WHICH ARE TO THE BACK OF CURB AND APRON ENDWALLS WHICH ARE TO THE END OF THE STRUCTURE .
 - THE CONTRACTOR SHALL PROVIDE ACCURATE AS-BUILT QUANTITIES FOR ALL UTILITIES INCLUDING ELEVATIONS, PIPE SIZE, STRUCTURE SIZE, AND PIPE LENGTHS.
 - CONTRACTOR SHALL NOTIFY ENGINEER OF ANY PLAN DEVIATIONS. ANY PLAN DEVIATIONS DURING CONSTRUCTION WILL REQUIRE PLANS TO BE MODIFIED AND SUBMITTED TO THE CITY ENGINEER FOR AS-BUILT PURPOSES.
 - ALL DIMENSIONS ARE TAKEN FROM THE FACE OF CURB, UNLESS OTHERWISE NOTED.
 - ALL SPOT ELEVATIONS ON CURB AND GUTTER ARE SHOWN AT THE TOP BACK OF CURB LOCATION, EXCEPT AT ADA RAMPS, WHICH ARE SHOWN AT THE EDGE OF PAVEMENT.
- COPIES OF ALL FIELD ORDERS AND SHOP DRAWINGS MUST BE GIVEN TO THE ENGINEER.
- THE ENGINEER MUST APPROVE THE SUBSTITUTION OF MATERIALS AND ANY CHANGES IN WORK.
 - CONTRACTOR SHALL ENSURE ALL BORROW PITS ARE CONSTRUCTED WITH THE SAFETY OF GENERAL PUBLIC IN MIND.
 - EROSION CONTROL AND STORMWATER MANAGEMENT PLANS MUST BE APPROVED BY THE CITY PRIOR TO THE START OF ANY LAND-DISTURBING ACTIVITIES.
 - NO BEDROCK ANTICIPATED.

UTILITIES

- THE CONTRACTOR SHALL VERIFY THE LOCATION OF ALL EXISTING UTILITIES PRIOR TO THE START OF CONSTRUCTION.
- THE PROPOSED IMPROVEMENTS SHALL BE CONSTRUCTED ACCORDING TO CITY OF MADISON STANDARD SPECIFICATIONS, LATEST EDITION OR MANUFACTURER'S SPECIFICATIONS.
- BEFORE PROCEEDING WITH ANY UTILITY CONSTRUCTION, THE CONTRACTOR SHALL EXCAVATE EACH EXISTING LATERAL OR POINT OF CONNECTION AND VERIFY THE LOCATION AND ELEVATION OF ALL UTILITIES. IF ANY EXISTING UTILITIES ARE NOT AS SHOWN ON THE DRAWINGS, THE CONTRACTOR SHALL NOTIFY THE ENGINEER IMMEDIATELY FOR POSSIBLE REDESIGN.
- MATERIALS FOR SANITARY SEWER SHALL BE AS FOLLOWS:
 SANITARY SEWER SHALL BE PVC IN ACCORDANCE WITH ASTM 3034, SDR-35 AND BEDDED WITH CLASS B BEDDING.
 ALL MANHOLE CASTINGS SHALL BE NEENAH R-1550-A WITH TYPE B NON-ROCKING LIDS AND CONCEALED PICK HOLES.
 EXCAVATED MATERIAL FROM THE TRENCH NOT SUITABLE FOR BACKFILL AS DEEMED BY THE CITY ENGINEER SHALL BE HAULED OFF-SITE AND SELECT TRENCH BACKFILL WILL BE REQUIRED .
- MATERIALS FOR WATER SERVICE SHALL BE AS FOLLOWS:
 WATER SERVICES SHALL HAVE A MINIMUM COVER OF 6.5'.
 CURB BOXES AND VALVES SHALL MEET CITY OF MADISON STANDARD SPECIFICATIONS, LATEST EDITION.
 EXCAVATED MATERIAL FROM THE TRENCH NOT SUITABLE FOR BACKFILL AS DEEMED BY THE ENGINEER SHALL BE HAULED OFF-SITE AND SELECT TRENCH BACKFILL WILL BE REQUIRED .
- STORM SEWER AND STORMWATER MANAGEMENT SHALL BE AS FOLLOWS:
 STORM SEWER PIPE BEDDING SHALL MEET THE CITY OF MADISON STANDARD SPECIFICATIONS, LATEST EDITION.
 MINIMUM COVER FOR ALL STORM SEWER SHALL BE 2'.
 EXCAVATED MATERIAL FROM THE TRENCH NOT SUITABLE FOR BACKFILL AS DEEMED BY THE ENGINEER SHALL BE HAULED OFF-SITE AND SELECT TRENCH BACKFILL WILL BE REQUIRED.
- EXTREME CAUTION MUST BE FOLLOWED REGARDING THE COMPACTION OF ALL UTILITY TRENCHES. MECHANICALLY COMPACTED GRANULAR BACKFILL IS REQUIRED UNDER AND WITHIN 5 FEET OF ALL PAVEMENT INCLUDING SIDEWALKS. FLOODING OF BACKFILL MATERIAL IS NOT ALLOWED. THE COST OF THIS GRANULAR MATERIAL AND ITS COMPACTION IS CONSIDERED INCIDENTAL AND SHALL BE INCLUDED IN THE COST OF THE PROPOSED UTILITY.
- THE CONTRACTOR IS RESPONSIBLE FOR PROVIDING THE OWNER WITH A SET OF MARKED-UP PRINTS SHOWING ALL CHANGES MADE DURING THE CONSTRUCTION PROCESS. ANY CHANGES TO THE DRAWINGS OR ADDITIONAL ITEMS MUST BE REPORTED TO THE OWNER.

GRADING

- THE PROPOSED IMPROVEMENTS SHALL BE CONSTRUCTED ACCORDING TO CITY OF MADISON STANDARD SPECIFICATIONS, LATEST EDITION.
- THE CONTRACTOR SHALL MAINTAIN SITE DRAINAGE THROUGHOUT CONSTRUCTION. THIS MAY INCLUDE THE EXCAVATION OF TEMPORARY DITCHES OR PUMPING TO ALLEVIATE WATER PONDING.
- SILT FENCE AND OTHER EROSION CONTROL FACILITIES MUST BE INSTALLED PRIOR TO CONSTRUCTION OR ANY OTHER LAND DISTURBING ACTIVITY. THE CONTRACTOR SHALL BE RESPONSIBLE FOR REMOVING ALL EROSION CONTROL FACILITIES ONCE THE SITE HAS BEEN STABILIZED WITH VEGETATION AND THE APPROVAL OF THE GOVERNING AGENCY.
- THE CONTRACTOR SHALL ASSUME SOLE RESPONSIBILITY FOR THE COMPUTATIONS OF ALL GRADING, CUT AND FILL CALCULATIONS AND FOR ACTUAL LAND BALANCE, INCLUDING UTILITY TRENCH SPOIL. THE CONTRACTOR SHALL IMPORT OR EXPORT MATERIAL AS NECESSARY TO COMPLETE THE PROJECT.
- GRADING SHALL CONSIST OF CLEARING AND GRUBBING EXISTING VEGETATION, STRIPPING TOPSOIL, REMOVAL OF EXISTING PAVEMENT OR FOUNDATIONS, IMPORTING OR EXPORTING MATERIAL TO ACHIEVE AND ON-SITE EARTHWORK BALANCE, GRADING THE PROPOSED BUILDING PADS AND PAVEMENT AREAS, SCARIFYING AND FINAL COMPACTION OF THE PAVEMENT SUBGRADE, AND PLACEMENT OF TOPSOIL.
- NO FILL SHALL BE PLACED ON A WET OR SOFT SUBGRADE.

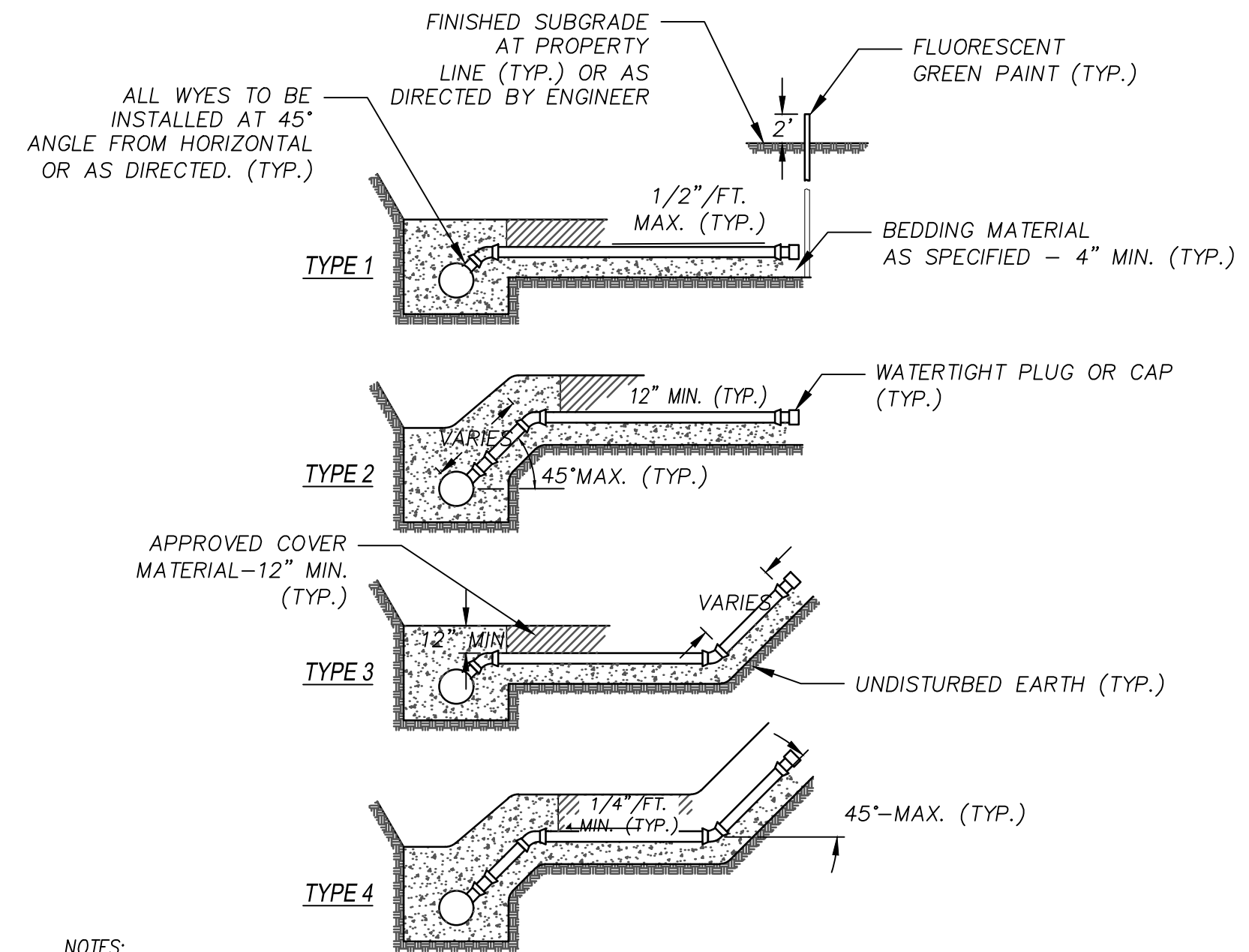

- NOTES:
- BEDDING MATERIAL SHALL BE 3/4" CLEAR STONE, UNLESS OTHERWISE APPROVED BY CITY ENGINEER
 - ENDS OF ALL LATERALS TO BE 10 FT. MIN. COVER AT END, AND BE MARKED BOTH BELOW AND ABOVE SURFACE WITH 4' LONG 2" x 4"
 - ALL NEW CONSTRUCTION TO BE PLACED ON UNDISTURBED GROUND OR SAND COMPACTED TO 95% MAXIMUM DENSITY
 - LATERAL MATERIAL INCLUDING FITTINGS SHALL BE OF SAME MATERIAL AS THE SEWER MAIN, OR AS DIRECTED BY ENGINEER
 - LATERALS TO TERMINATE 5' FROM BUILDING PAD.

1 SANITARY LATERAL DETAIL
C7.0 SCALE: NTS

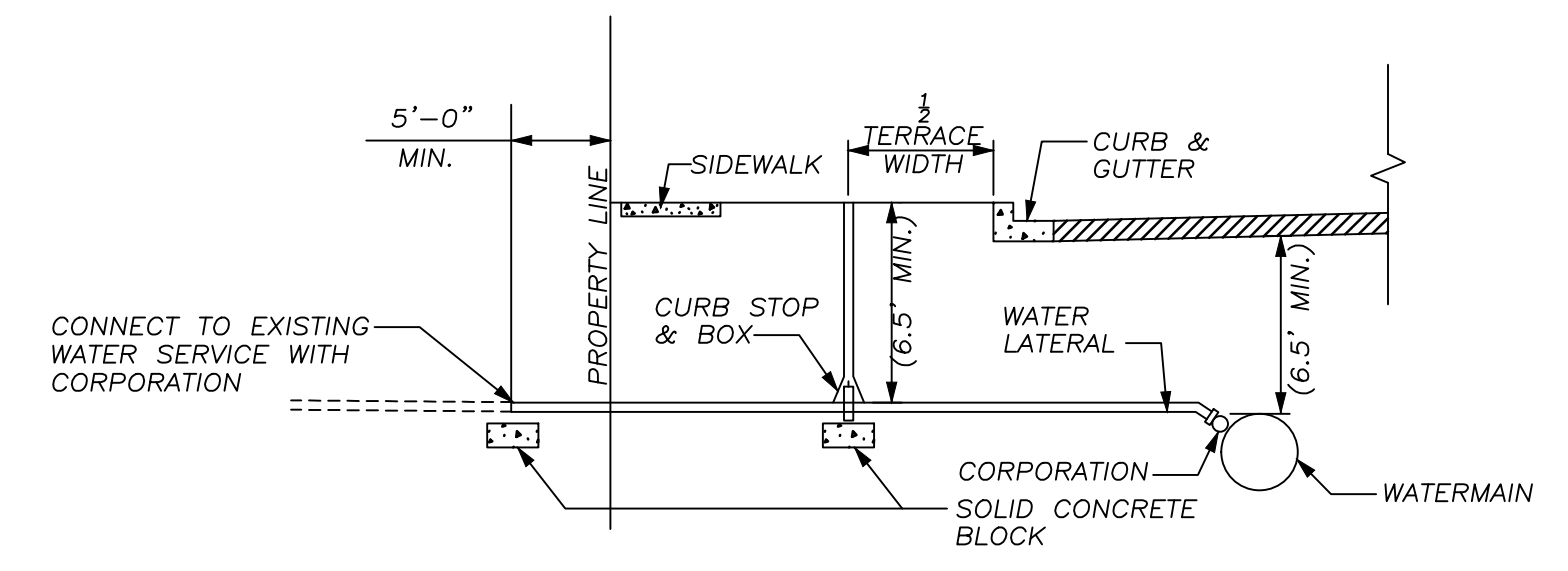

1 WATER LATERAL DETAIL
C7.0 SCALE: NTS

8549 & 8557 ELDERBERRY ROAD

MISC. DETAILS

MADISON, DANE COUNTY, WI

SNYDER & ASSOCIATES, INC. |

2727 S.W. SNYDER BLVD
ANKENY, IOWA 50023
515-964-2020 | www.snyder-associates.com



MARK	REVISION	DATE	BY
Engineer: BCA	Checked By: MLC	Date: 06-26-2019	Scale: 1" = AS SHOWN
Technician: BCA			T-R-S: TTN-RRW-SS
Project No: 119.0587.30			Sheet C 8.0

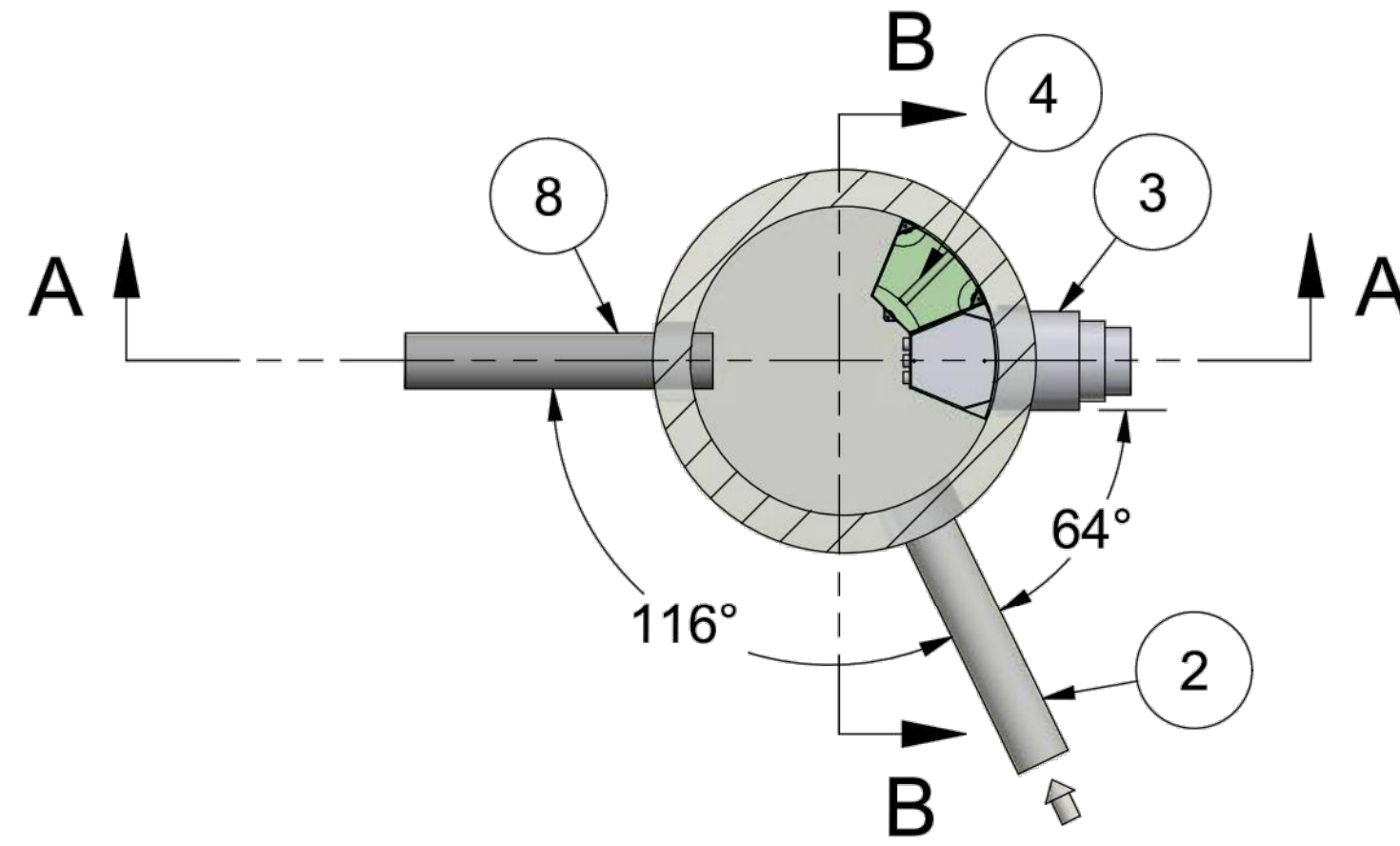

1 SECTION C-C
C8.0 SCALE: NTS

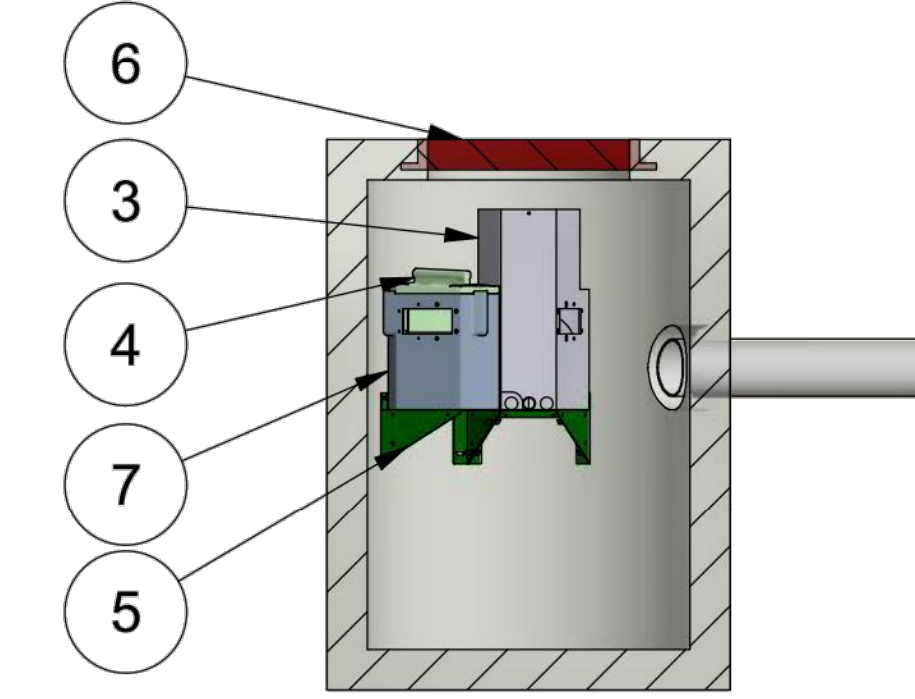

1 SECTION B-B
C8.0 SCALE: NTS

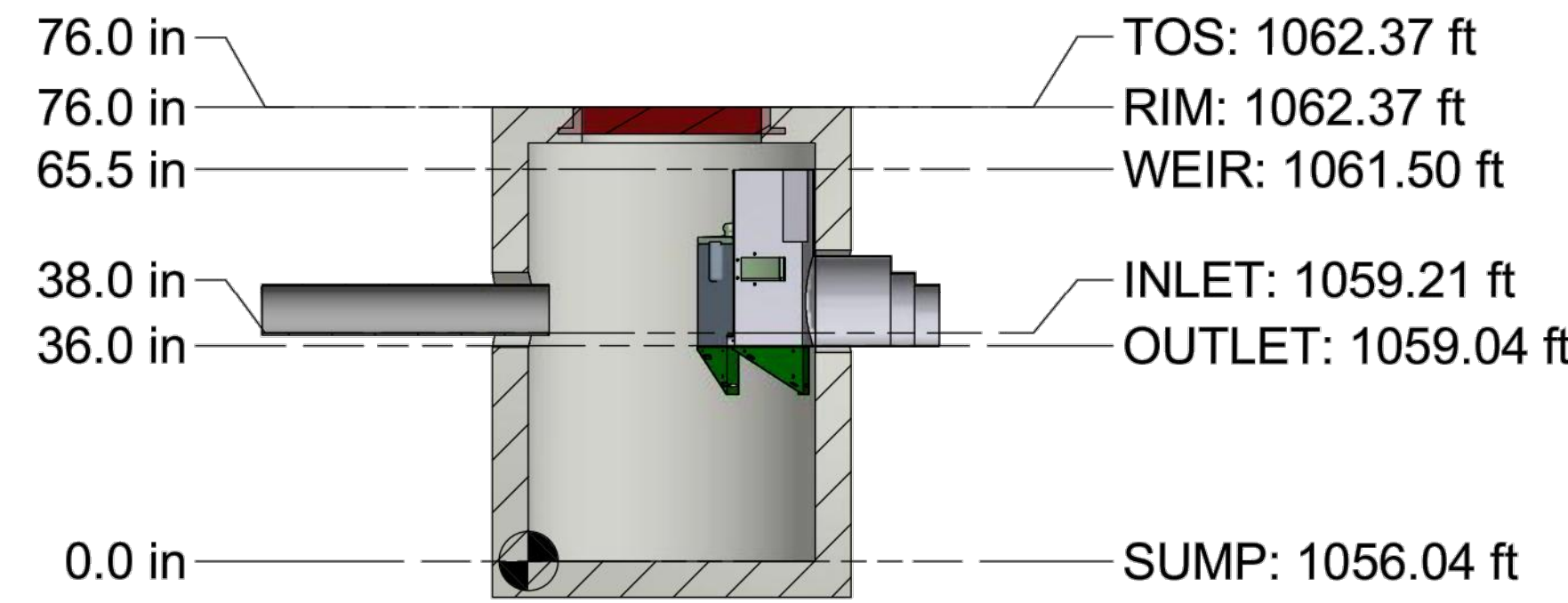

1 SECTION A-A
C8.0 SCALE: NTS

OUTLET PIPE STUB SIZE INFORMATION
 Outside Diameter: 10.5", 12.5" or 15.3" OD
 Concrete Penetration: Pipe Boot (by Hydro)
 Hook-up: Fernco-type coupling (by others)

CAPACITIES:

1. Minimum performance: 80% removal. NJDEP - NJDEP Blend; NJCAT, Sil-Co-Sil 106 (d50 = 22 microns) at the peak treatment flow.
2. NJDEP peak treatment flow: .056 cfs (25 gpm) per module, CPZ
3. Maximum number of modules per outlet module: 38 **

ADDITIONAL DESIGN INFORMATION:

1. * Normal operating W.S.E. is 2.46' above the outlet invert at the peak treatment flow of .056 cfs (25 gpm) per module. For a given flow the head requirement can be reduced by adding additional filters.
2. ** Treatment flows that require more modules will require a larger vault design or different arrangement.
3. Media Types Available: New Jersey - Ribbons; Elsewhere - CPZ

PARTS LIST				
ITEM	QTY	DESCRIPTION	TYPE	SIZE (in)
1	1	PRECAST MANHOLE		48
2	1	INLET PIPE	PVC	8
3	1	OUTLET MODULE		
4	1	MODULE LID		
5	2	SUPPORT FRAME		
6	1	30" FRAME AND COVER		30
7	1	MODULE BODY		
8	1	AUXILLIARY PIPE 1	PVC	8

ANY WARRANTY GIVEN BY HYDRO INTERNATIONAL WILL APPLY ONLY TO THOSE ITEMS SUPPLIED BY IT. ACCORDINGLY HYDRO INTERNATIONAL CANNOT ACCEPT ANY RESPONSIBILITY FOR ANY STRUCTURE, PLANT, OR EQUIPMENT, (OR THE PERFORMANCE THERE OF) DESIGNED, BUILT, MANUFACTURED, OR SUPPLIED BY ANY THIRD PARTY. HYDRO INTERNATIONAL HAVE A POLICY OF CONTINUOUS DEVELOPMENT AND RESERVE THE RIGHT TO AMEND THE SPECIFICATION. HYDRO INTERNATIONAL CANNOT ACCEPT LIABILITY FOR PERFORMANCE OF ITS EQUIPMENT, (OR ANY PART THEREOF), IF THE EQUIPMENT IS SUBJECT TO CONDITIONS OUTSIDE ANY DESIGN SPECIFICATION. HYDRO INTERNATIONAL OWNS THE COPYRIGHT OF THIS DRAWING, WHICH IS SUPPLIED IN CONFIDENCE. IT MUST NOT BE USED FOR ANY PURPOSE OTHER THAN THAT FOR WHICH IT IS SUPPLIED AND MUST NOT BE REPRODUCED, IN WHOLE OR IN PART, WITHOUT PRIOR PERMISSION IN WRITING FROM HYDRO INTERNATIONAL.
 ©2019 HYDRO INTERNATIONAL

DO NOT SCALE DRAWING
 UNLESS OTHERWISE SPECIFIED, DIMENSIONS ARE IN INCHES.

TOLERANCES ARE:
 FRACTIONS ± 1/16
 DECIMALS:
 X.X ± .06
 X.XX ± .03
 X.XXX ± .015
 ANGLES: ± .5°

PROJECTION

COMMENTS:
 1. STRUCTURE WALL AND SLAB THICKNESSES ARE NOT TO SCALE.
 2. CONTACT HYDRO INTERNATIONAL FOR A BOTTOM OF STRUCTURE ELEVATION PRIOR TO SETTING THE STRUCTURE

DISTRIBUTED BY
 ADVANCED DRAINAGE SYSTEMS, INC.

 PLEASE CALL OR EMAIL
 JAKE BRUNOEHLER FOR
 PRICING
 Jake.Brunoehler@ads-pipe.com 262-794-2306

REVISION HISTORY			
REV	BY	DESCRIPTION	DATE
-	GW	FIRST RELEASE	6/27/2019

DATE: 6/27/2019
 SCALE: 1:50

DRAWN BY: GW
 CHECKED BY:
 APPROVED BY:

Title
UP-FLO FILTER
 4ft Manhole
 1 MODULES
 WQU
 ELDERBERRY ROAD DUPLEXES
 MADISON, WI



94 Hutchins Drive
 Portland, ME 04102
 Tel: +1 (207) 756-6200
 Fax: +1 (207) 756-6212
 hydro-int.com

Patent: www.hydro-int.com/patents

WEIGHT: 3883.1 lbmass
 MATERIAL:

NEXT ASSEMBLY:
 19_12_1875-1

DRAWING NO.:
 19_12_1875-UFF-1

SHEET SIZE: B
 SHEET: 1 OF 1
 Rev: -

MARK	REVISION	DATE	BY
Engineer: BCA	Checked By: MLC	Date: 06-26-2019	Scale: 1" = AS SHOWN
Technician: BCA	Date:		T-R-S: TTN-RRW-SS
Project No: 119.0587.30			Sheet C9.0

8549 & 8557 ELDERBERRY ROAD
 UP-FLO FILTER DETAIL
 MADISON, DANE COUNTY, WI
 SNYDER & ASSOCIATES, INC. | 2727 S.W. SNYDER BLVD ANKENY, IOWA 50023 515-964-2020 | www.snyder-associates.com

Project No: 119.0587.30
 Sheet C9.0

PROPOSED NURSERY STOCK TYPE	SIZE	QTY	ROOT TYPE	PLANT NAME	SIZE	QTY	ROOT	PNTS.
CANOPY TREES								
Swamp White Oak	2" caliper	3	B&B	Proposed Trees and Shrubs				
Ivory Silk Lilac	2" caliper	4	B&B	Swamp White Oaks, deciduous trees	2 1/2" caliper	3	B&B	105
Snow Drift Flowering Crabapple	2" caliper	2	B&B	Concolor Fir, tall evergreen tree	5' height	5	B&B	175
EVERGREENS								
Concolor Fir	4' height	5	B&B	Ivory Silk Lilac, ornamental trees	2" caliper	4	B&B	90
Techny Arborvitae	5' height	4	B&B	Snow Drift Flowering Crabs, ornamental trees	2" caliper	2	B&B	30
Emerald Arborvitae	5' height	5	B&B	Deciduous Shrubs, Chokeberry, Spirea, Hydrangea, Ninebark	#3 container	47	Pots	141
Green Velvet Boxwood	18" wide	6	#5 pot	Evergreen Shrubs, Boxwood	#3 container	6	Pots	24
DECIDUOUS SHRUBS								
Korean Lilac	2 1/2' height	7	B&B	TOTAL LANDSCAPE POINTS REQUIRED				458
Iroquois Beauty Chokeberry	12" height	9	#3 pot	TOTAL LANDSCAPE PLAN POINTS ACHIEVED				565
Magic Carpet Spirea	12" height	15	#3 pot					
Little Quick-fire Hydrangea	15" height	11	#3 pot					
Summer Wine Ninebark	15" height	5	#3 pot					
PERENNIALS								
Regal Splendor Hosta		12	#1 pot					

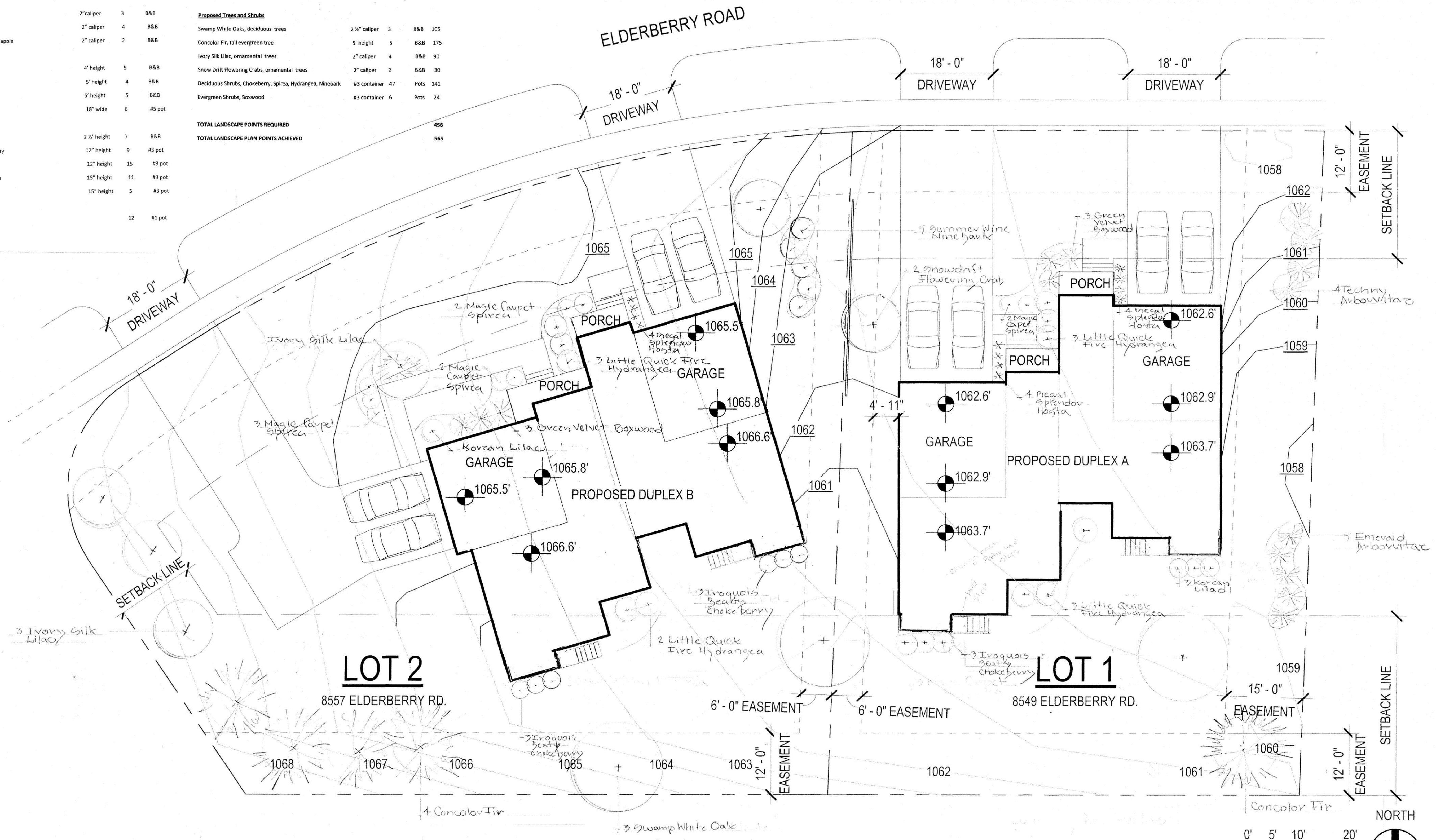

1 SITE PLAN AND LANDSCAPE PLAN
1" = 20'-0"



architecture · interior design · planning
6515 Grand Teton Plaza, Suite 120, Madison, Wisconsin 53719
p608.829.4444 f608.829.4445 dimensionivmadison.com

A5
ELDERBERRY DUPLEXES
MADISON WI



LANDSCAPE PLAN AND PLANTING SCHEDULE
09/11/2019
19014

G. Ophime 9/10/19

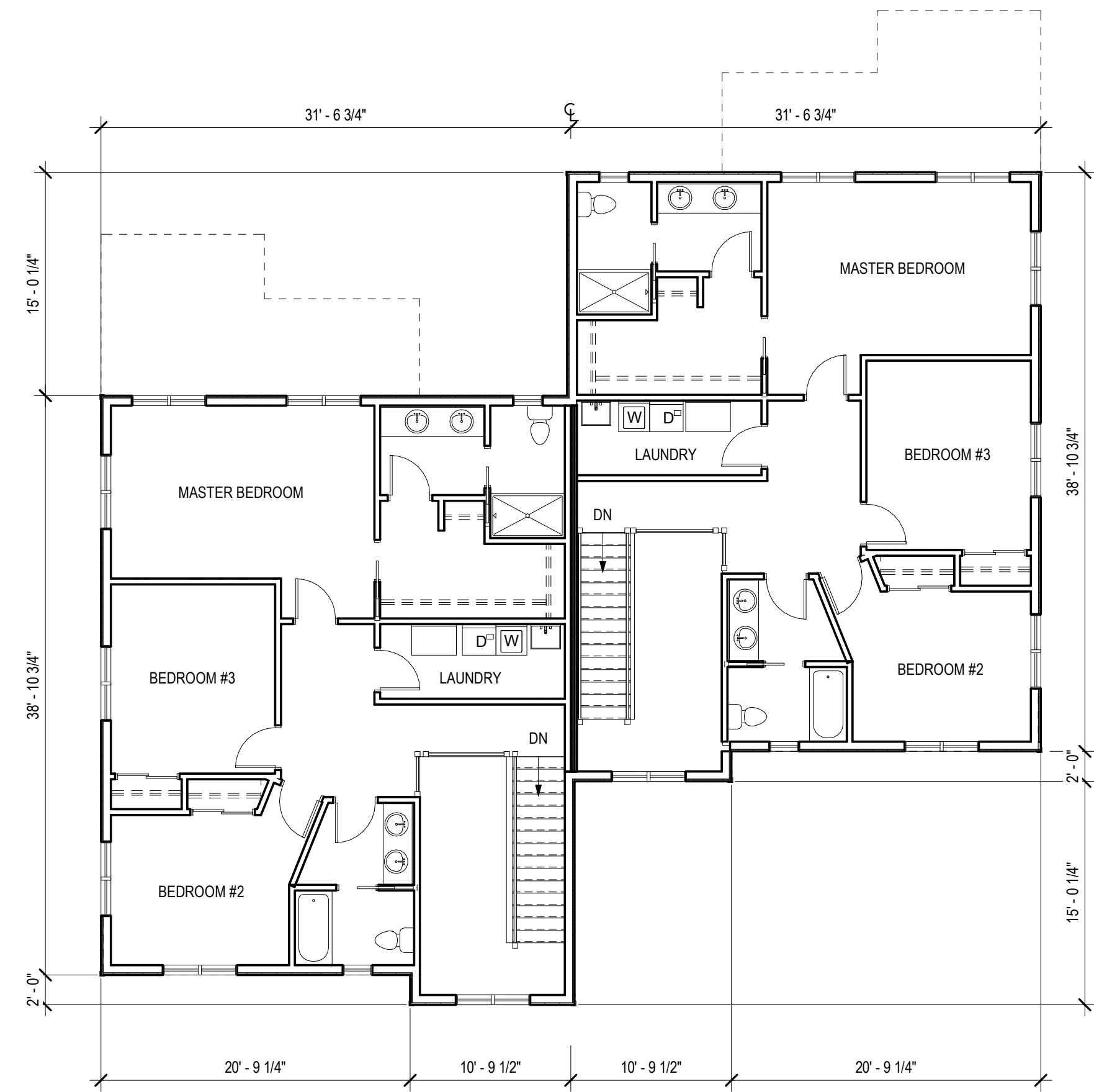

2 SECOND FLOOR PLAN - DUPLEX A (8549)
 1/8" = 1'-0"

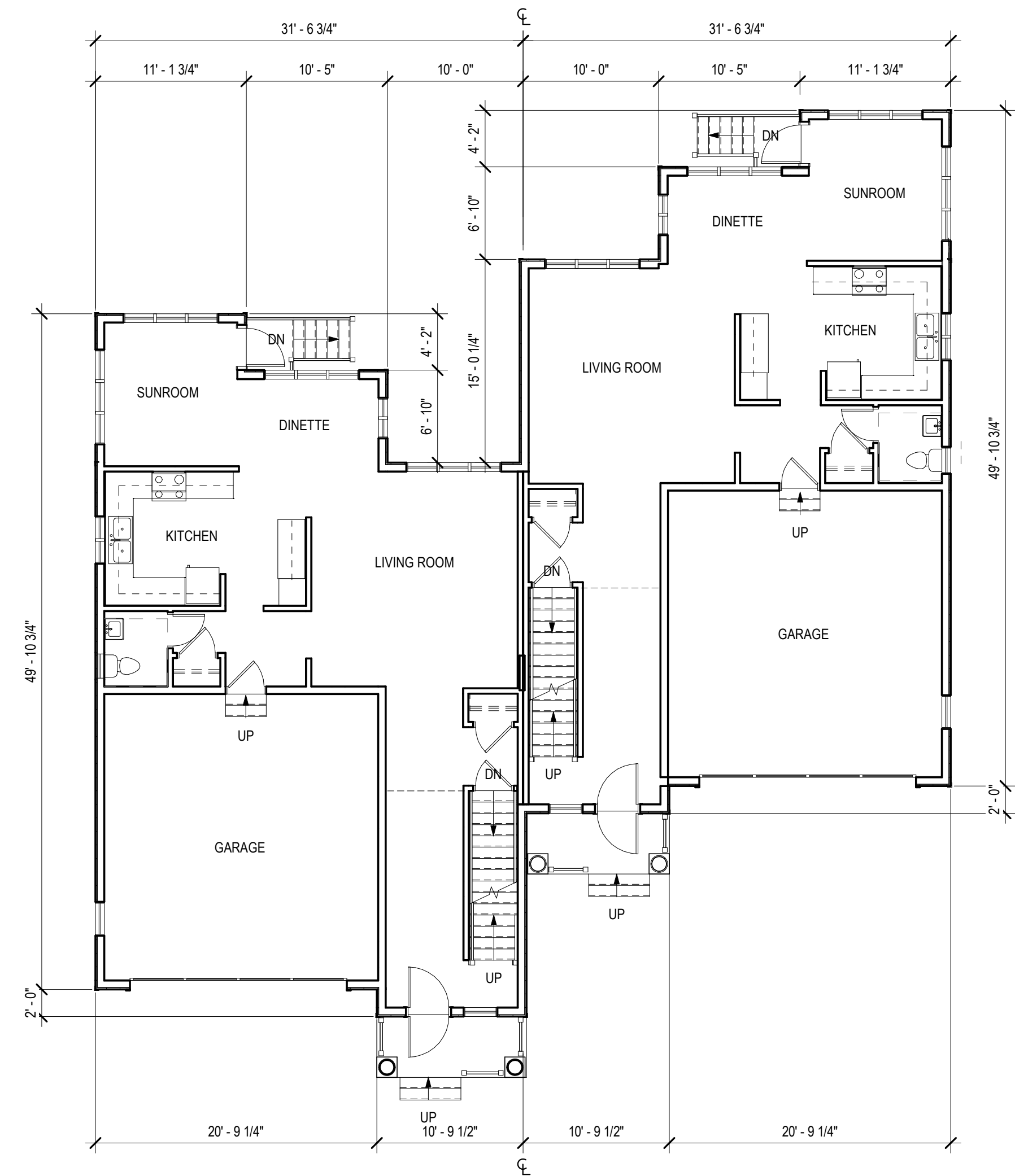

1 FIRST FLOOR PLAN - DUPLEX A (8549)
 1/8" = 1'-0"
 1/16" = 1'-0" @ 11"X17" SHEET SIZE

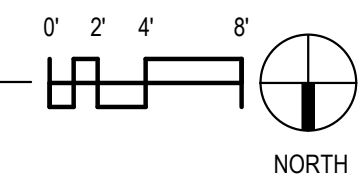

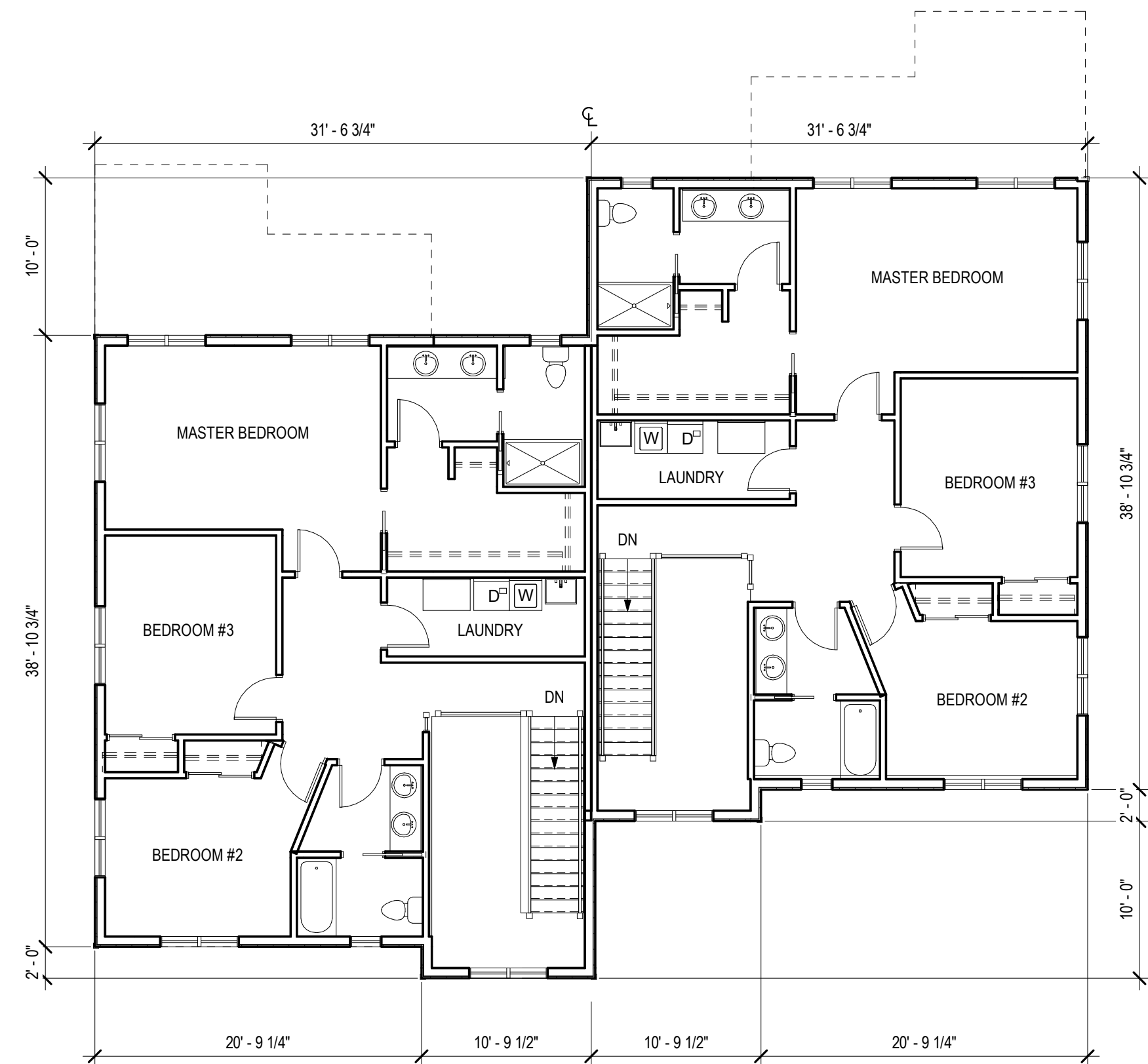

2 SECOND FLOOR PLAN - DUPLEX B (8557)
1/8" = 1'-0"

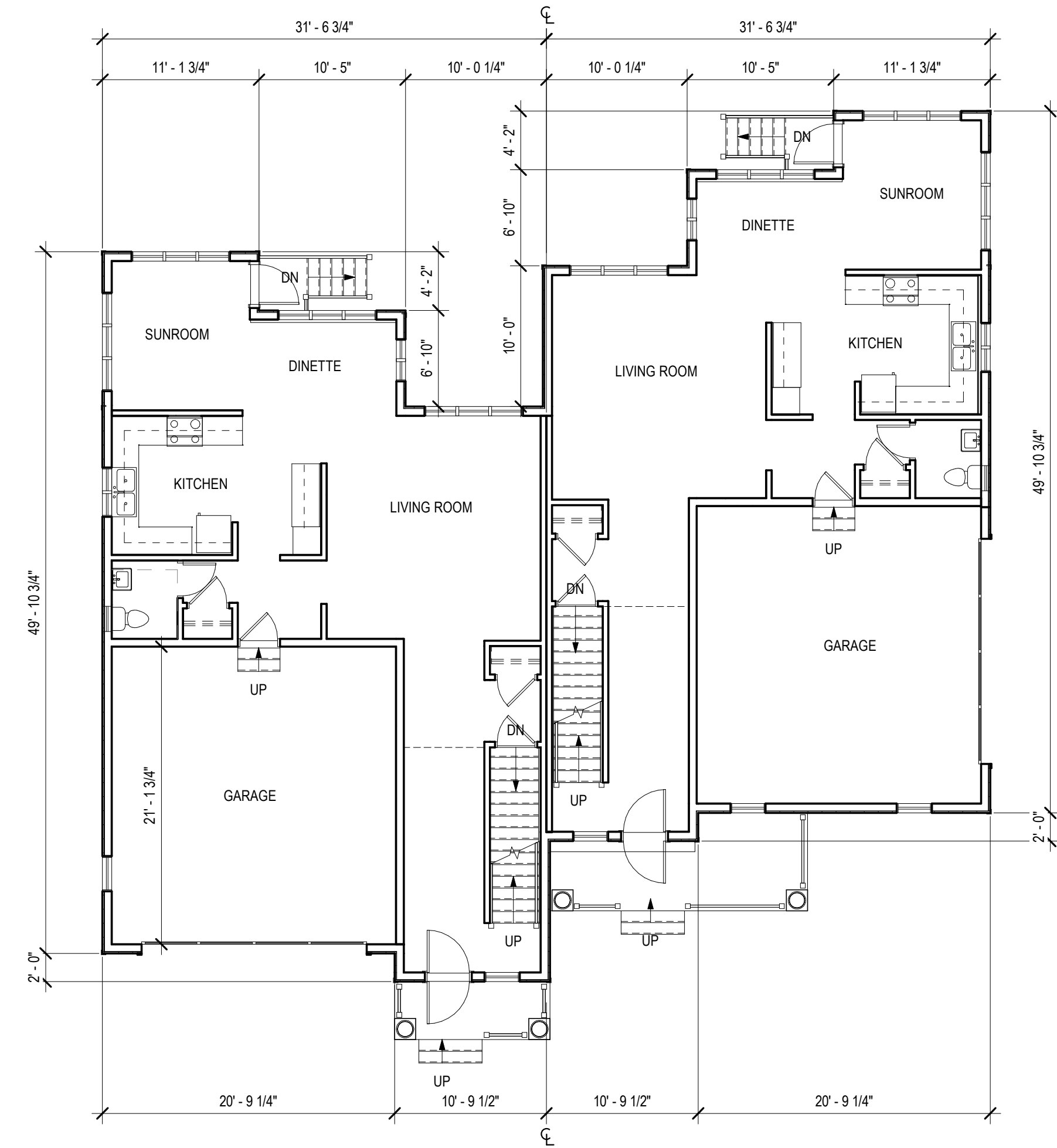

1 FIRST FLOOR PLAN - DUPLEX B (8557)
1/8" = 1'-0"
1/16" = 1'-0" @ 11"x17" SHEET SIZE

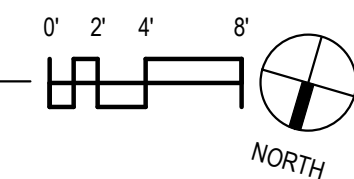

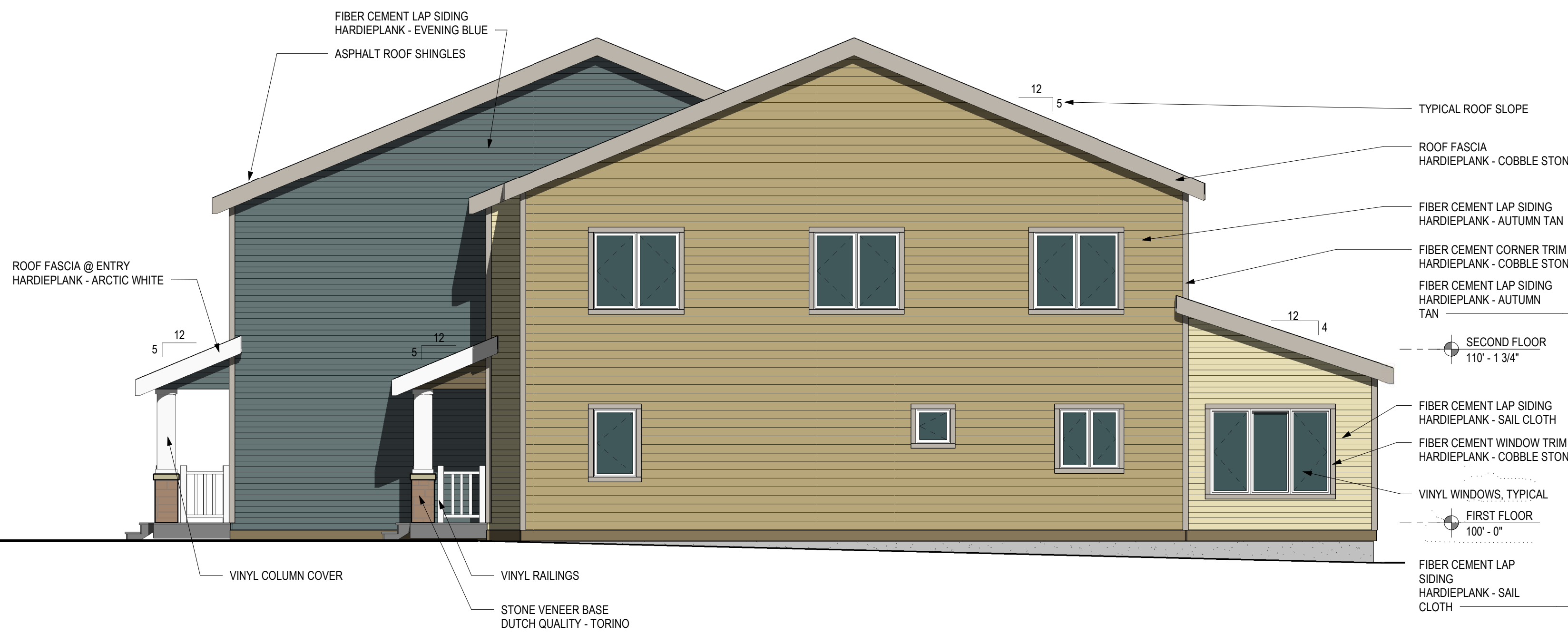

4 WEST ELEVATION - DUPLEX (A)
3/16" = 1'-0"



3 SOUTH ELEVATION - DUPLEX (A)
3/16" = 1'-0"

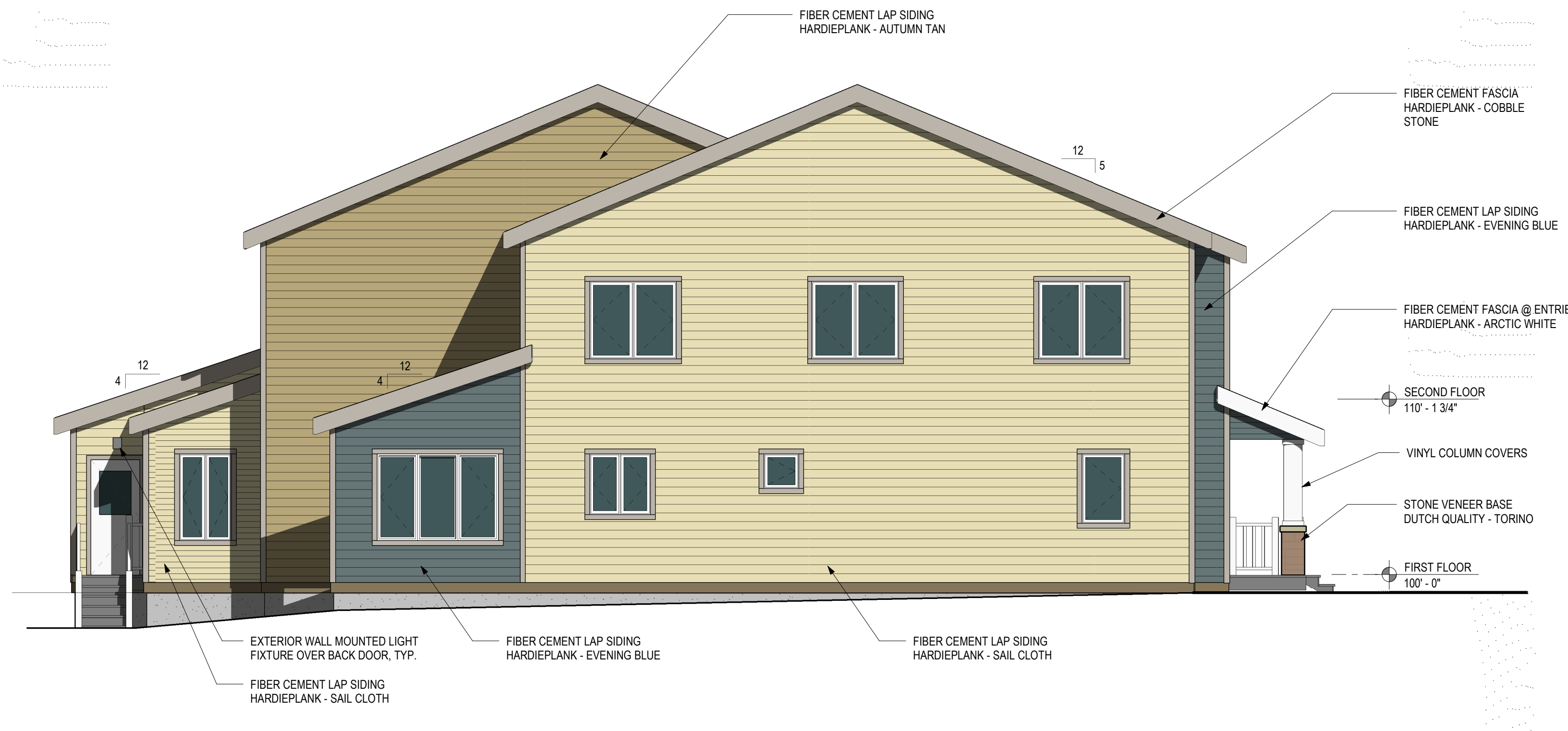

2 EAST ELEVATION - DUPLEX (A)
3/16" = 1'-0"

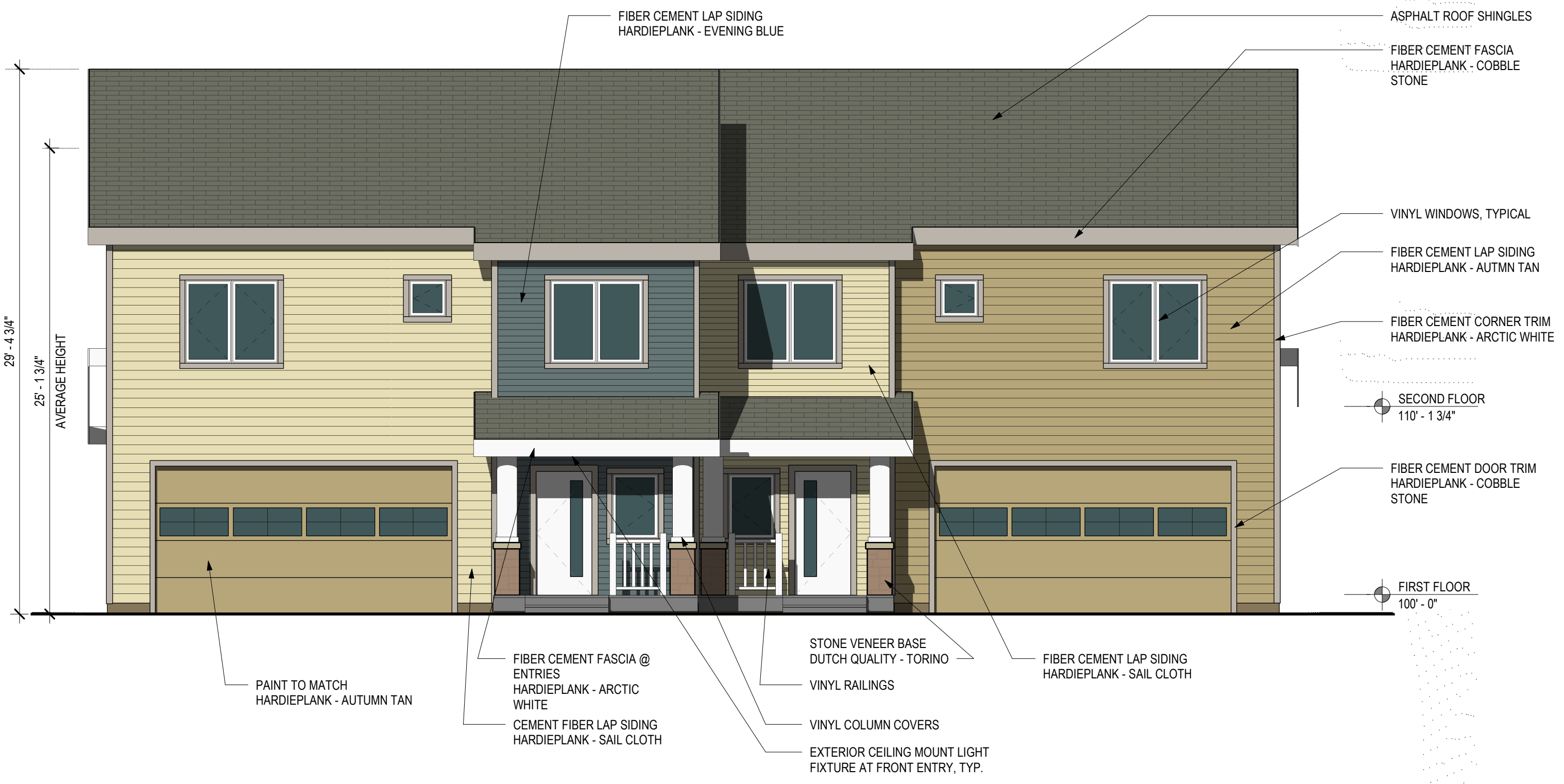

1 NORTH ELEVATION - DUPLEX (A)
3/16" = 1'-0"
3/32" = 1'-0" @ 11x17" SHEET SIZE

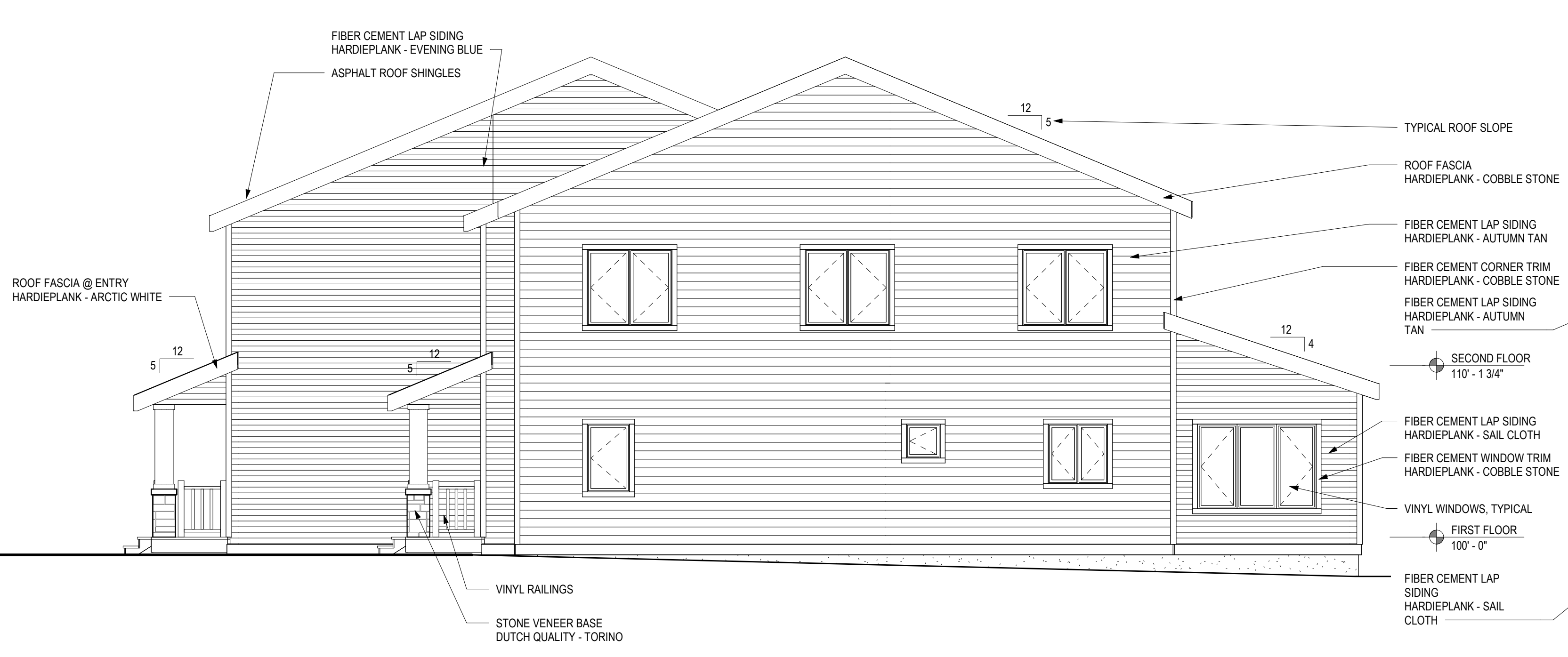

4 WEST ELEVATION - DUPLEX (A)
3/16" = 1'-0"



3 SOUTH ELEVATION - DUPLEX (A)
3/16" = 1'-0"

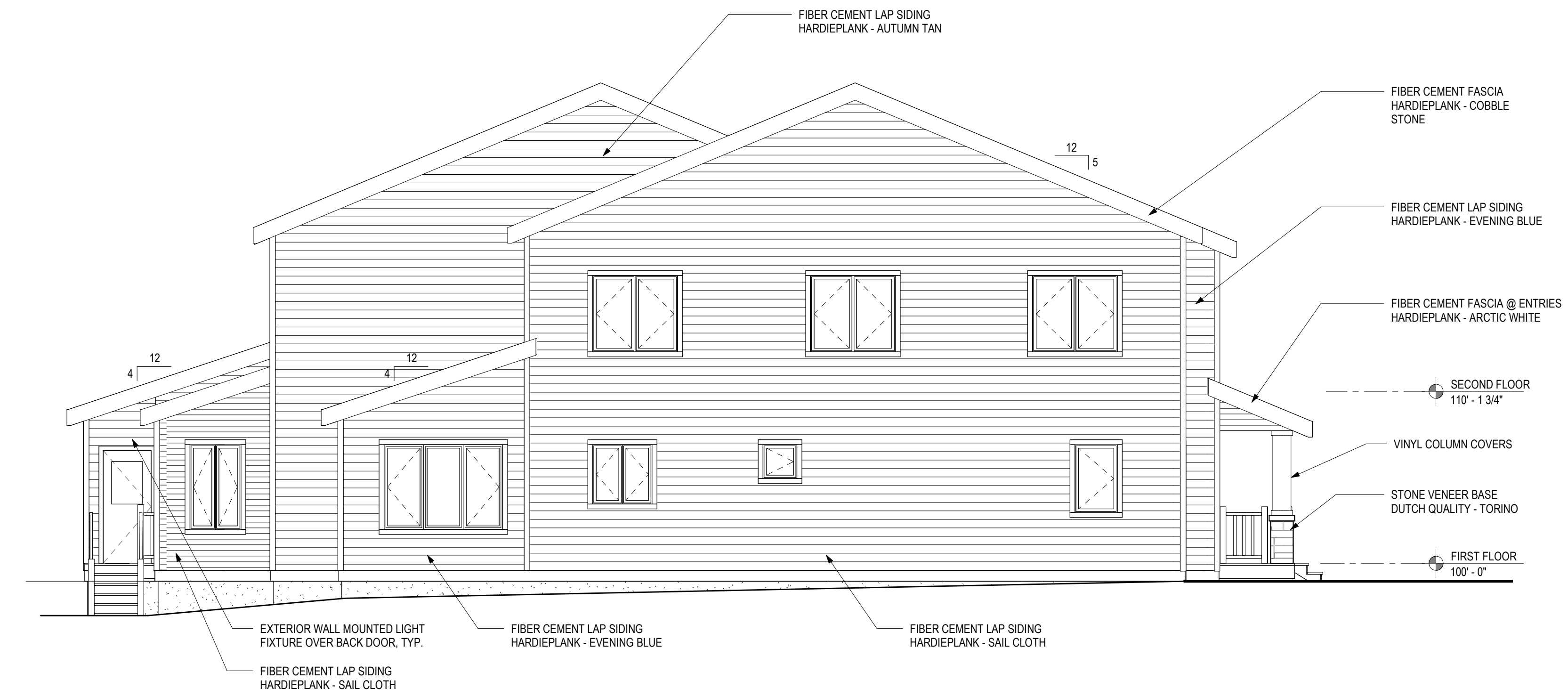

2 EAST ELEVATION - DUPLEX (A)
3/16" = 1'-0"

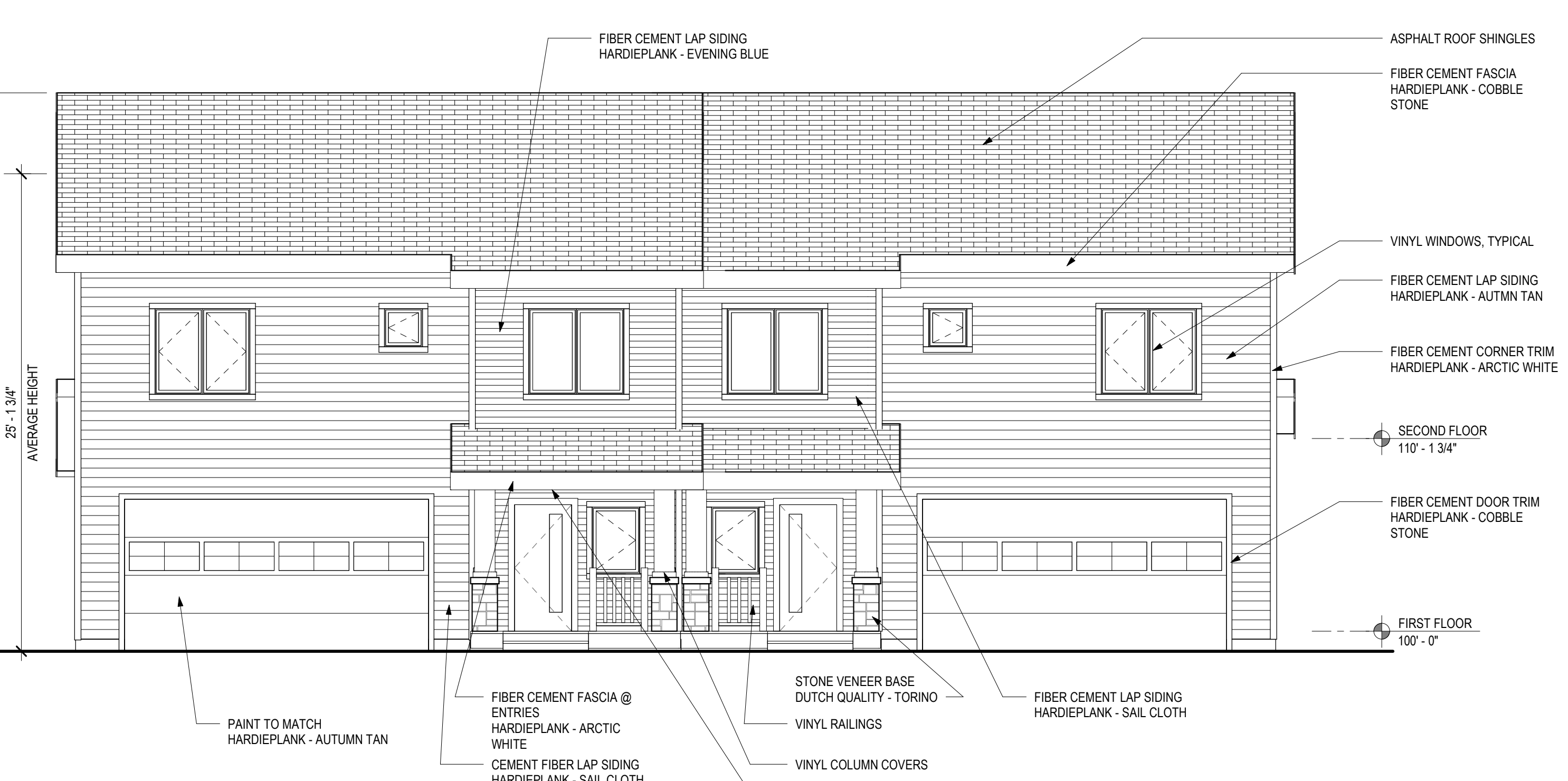

1 NORTH ELEVATION - DUPLEX (A)
3/16" = 1'-0"
3/32" = 1'-0" @ 11"x17" SHEET SIZE

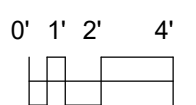

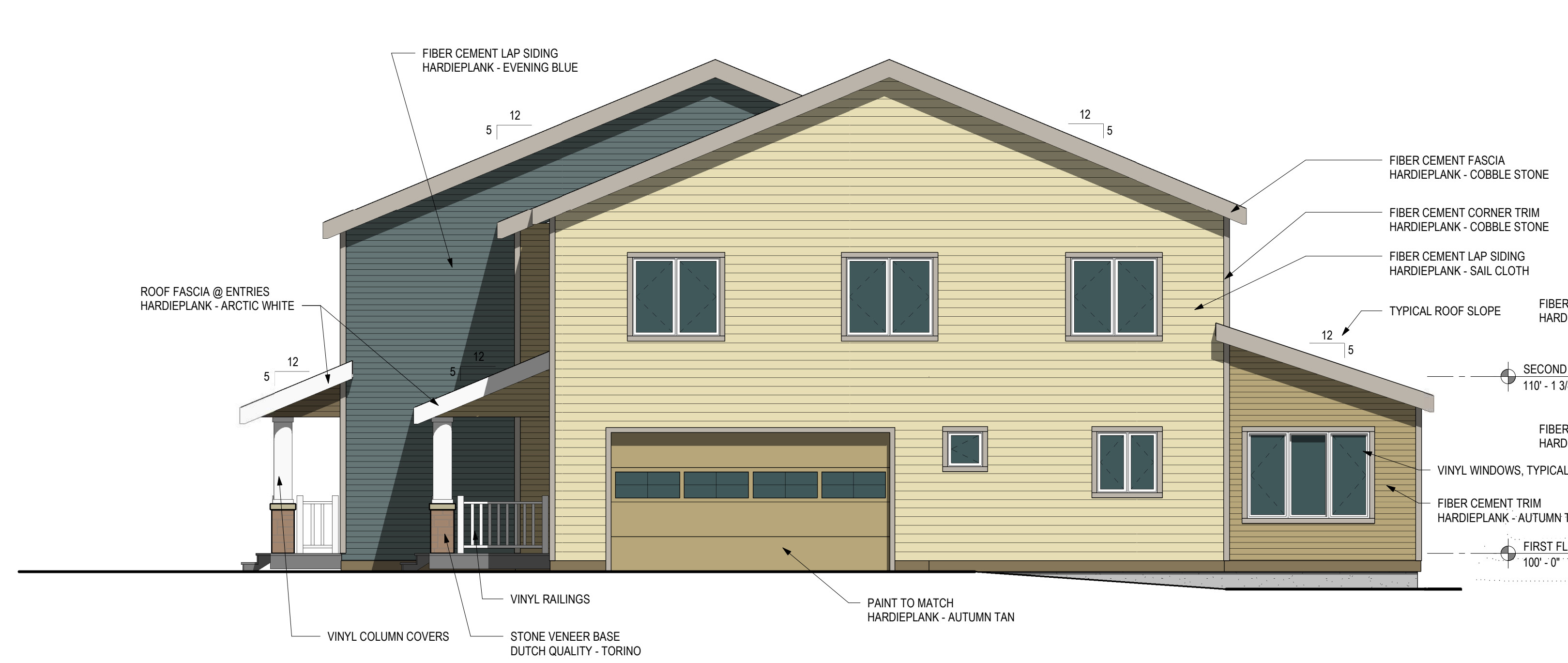

4 WEST ELEVATION - DUPLEX (B)
3/16" = 1'-0"



3 SOUTH ELEVATION - DUPLEX (B)
3/16" = 1'-0"

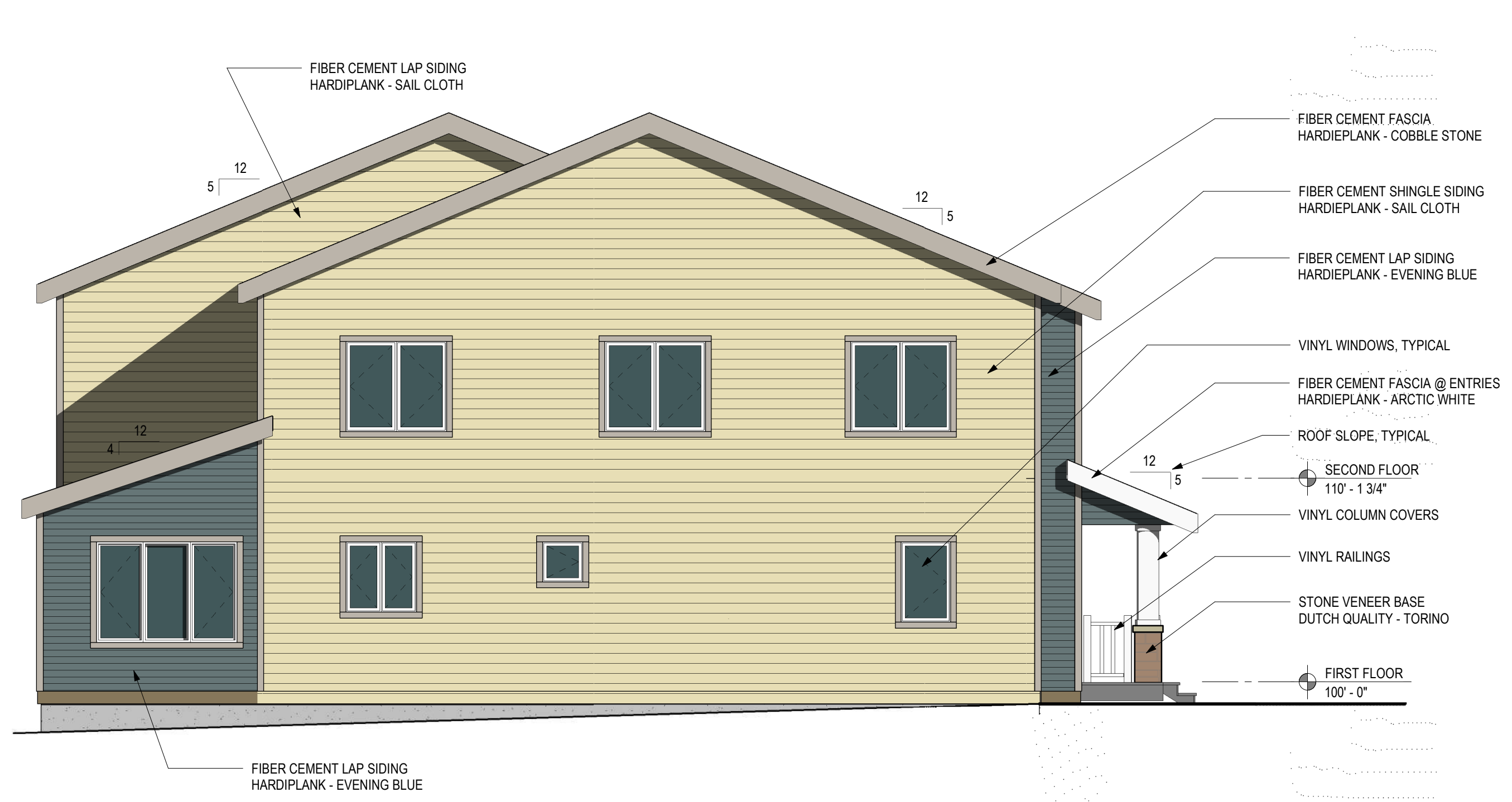

2 EAST ELEVATION - DUPLEX (B)
3/16" = 1'-0"

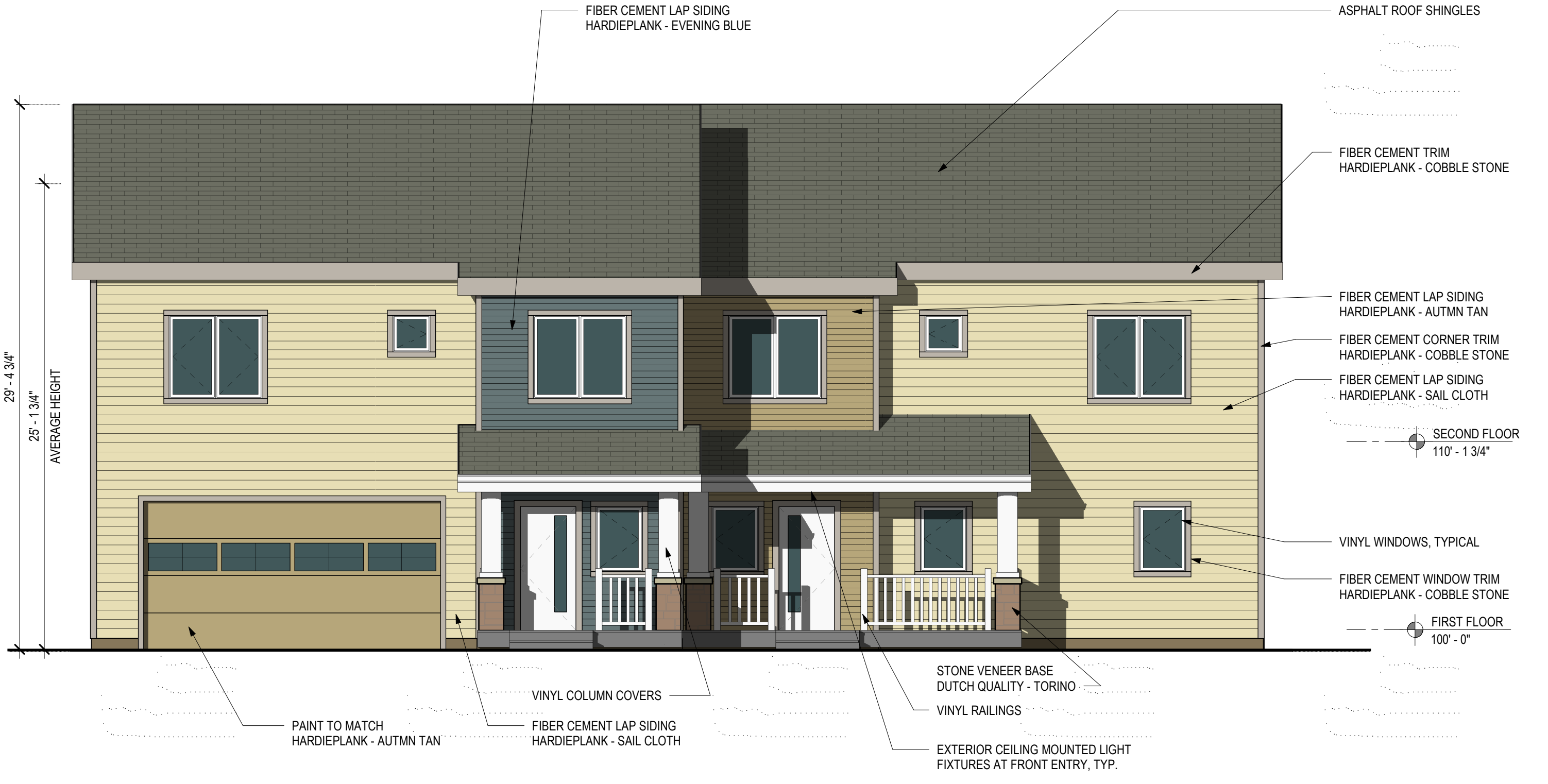

1 NORTH ELEVATION - DUPLEX (B)
3/16" = 1'-0"
3/32" = 1'-0" @ 11x17" SHEET SIZE

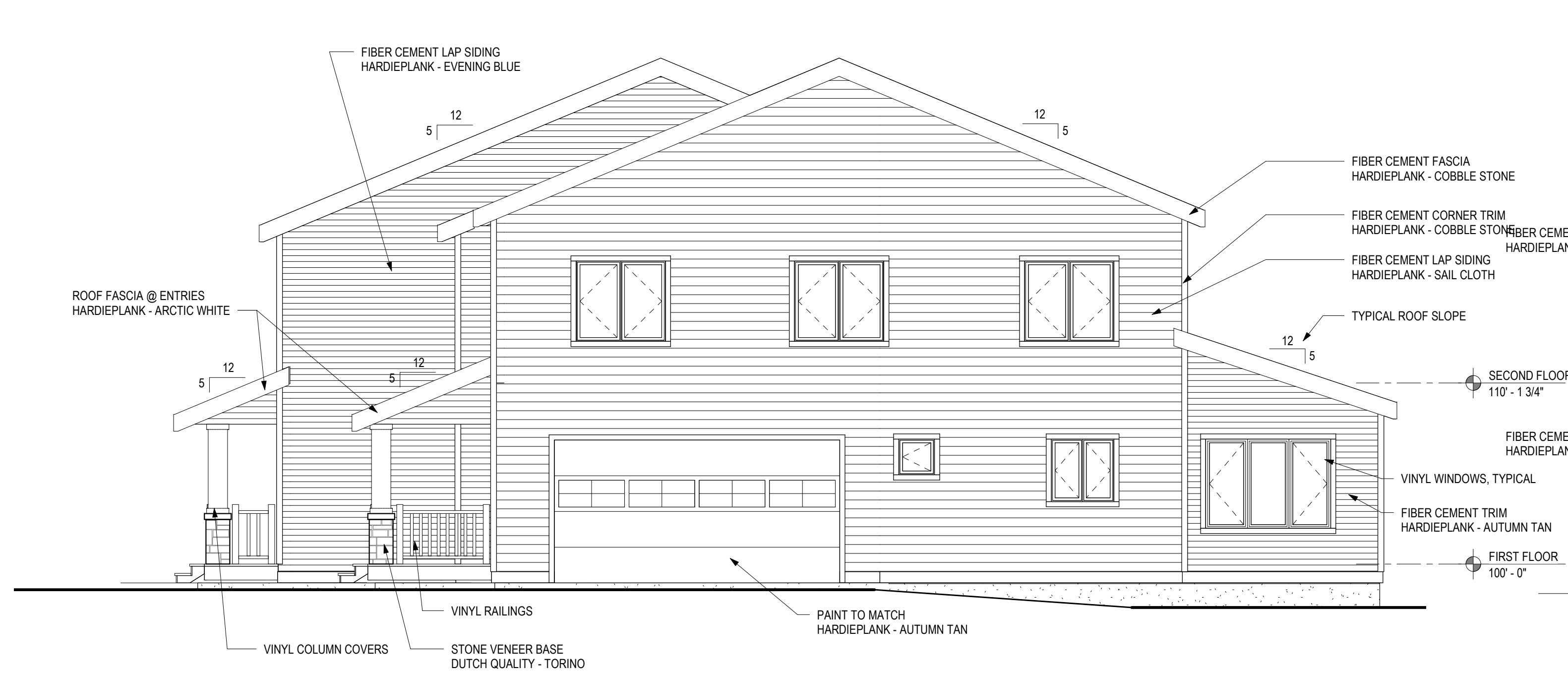

4 WEST ELEVATION - DUPLEX (B)
3/16" = 1'-0"



3 SOUTH ELEVATION - DUPLEX (B)
3/16" = 1'-0"

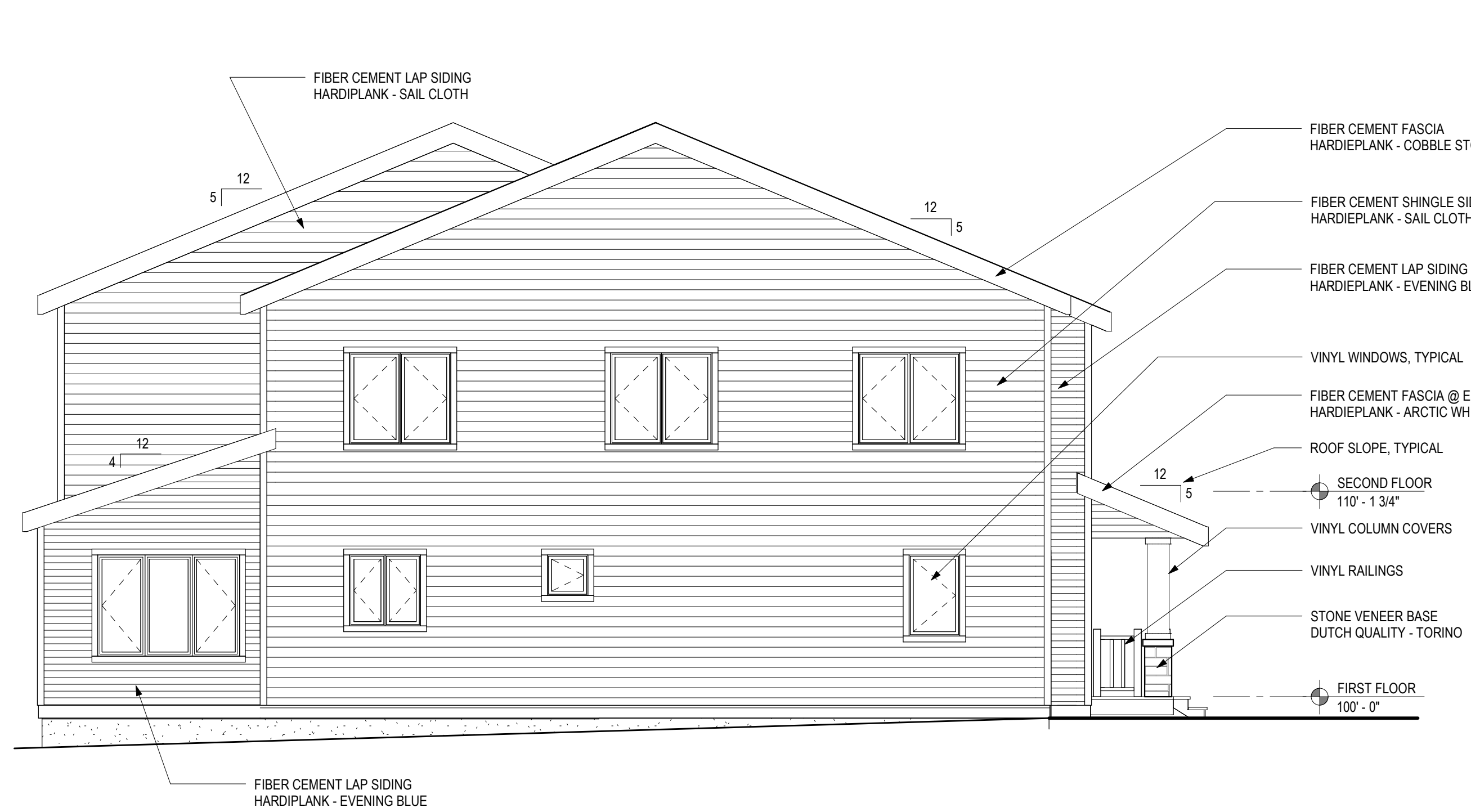

2 EAST ELEVATION - DUPLEX (B)
3/16" = 1'-0"



1 NORTH ELEVATION - DUPLEX (B)
3/16" = 1'-0"
3/32" = 1'-0" @ 11"x17" SHEET SIZE





HARDIEPLANK - EVENING BLUE

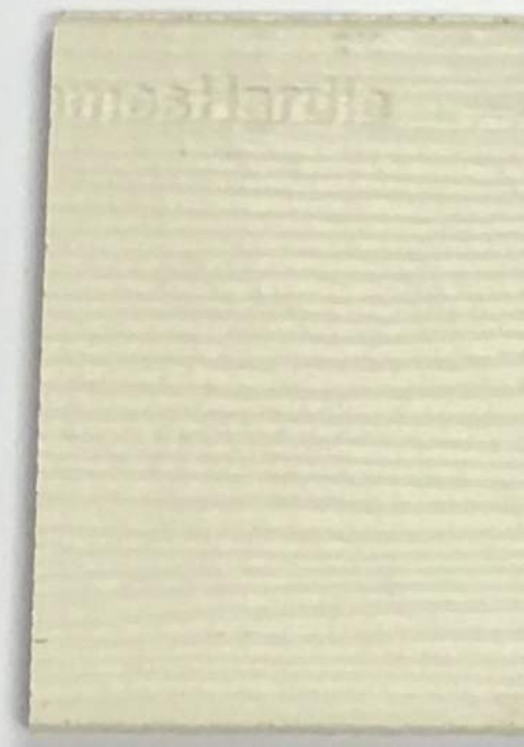

HARDIEPLANK - SAIL CLOTH



HARDIEPLANK - AUTUMN TAN

